

YASKAWA

PROFINET Communications

Sigma-7 SERVOPACK SGD7S-□□□AC0□□□□, 200 V

Technical Manual



PROFI[®]
NET

Table of contents

1	General	16
1.1	About this Manual	16
1.2	Outline of Manual	16
1.3	Related Documents	18
1.4	Using This Manual	23
1.5	Safety Precautions	27
1.5.1	Safety Information	27
1.5.2	Safety Precautions That Must Always Be Observed	27
1.6	Warranty	37
1.7	Compliance with UL Standards, EU Directives, and Other Safety Standards	40
2	Basic Information on SERVOPACKs	43
2.1	Overview	43
2.2	The Σ -7 Series	43
2.3	Introduction to PROFINET	43
2.3.1	Overview	43
2.3.2	Data Types	43
2.3.3	Data Ranges	44
2.4	Interpreting the Nameplate	44
2.5	Part Names	45
2.6	Model Designations	47
2.6.1	Interpreting SERVOPACK Model Numbers	47
2.6.2	Interpreting Servomotor Model Numbers	47
2.7	Combinations of SERVOPACKs and Servomotors	49
2.7.1	Combinations of Rotary Servomotors and SERVOPACKs	49
2.7.2	Combinations of Direct Drive Servomotors and SERVOPACKs	50
2.7.3	Combinations of Linear Servomotors and SERVOPACKs	52
2.8	Functions	54
3	Selecting a SERVOPACK	58
3.1	Overview	58
3.2	Ratings and Specifications	58
3.2.1	Ratings	58
3.2.2	SERVOPACK Overload Protection Characteristics	59
3.2.3	Specifications	60
3.3	Block Diagrams	65
3.4	External Dimensions	68
3.4.1	Front Cover Dimensions and Connector Specifications	68
3.4.2	SERVOPACK External Dimensions	69
3.5	Examples of Standard Connections between SERVOPACKs and Peripheral Devices	72

4	SERVOPACK Installation	74
4.1	Overview	74
4.2	Installation Precautions	74
4.3	Mounting Types and Orientation	74
4.4	Mounting Hole Dimensions	76
4.5	Mounting Interval	78
4.5.1	Installing One SERVOPACK in a Control Panel	78
4.5.2	Installing More Than One SERVOPACK in a Control Panel	78
4.6	Monitoring the Installation Environment	79
4.7	Derating Specifications	80
4.8	EMC Installation Conditions	80
5	Wiring and Connecting SERVOPACKs	83
5.1	Overview	83
5.2	Wiring and Connecting SERVOPACKs	83
5.2.1	General Precautions	83
5.2.2	Countermeasures against Noise	86
5.2.3	Grounding	89
5.3	Basic Wiring Diagrams	90
5.4	Wiring the Power Supply to the SERVOPACK	91
5.4.1	Overview	91
5.4.2	Terminal Symbols and Terminal Names	91
5.4.3	Wiring Procedure for Main Circuit Connector	94
5.4.4	Power ON Sequence	95
5.4.5	Power Supply Wiring Diagrams	97
5.4.6	Wiring Regenerative Resistors	102
5.4.7	Wiring Reactors for Harmonic Suppression	104
5.5	Wiring Servomotors	105
5.5.1	Terminal Symbols and Terminal Names	105
5.5.2	Pin Arrangement of Encoder Connector (CN2)	105
5.5.3	Wiring the SERVOPACK to the Encoder	106
5.5.4	Wiring the SERVOPACK to the Holding Brake	112
5.6	Connecting I/O Signals	114
5.6.1	I/O Signal Connector (CN1) Names and Functions	114
5.6.2	I/O Signal Connector (CN1) Pin Arrangement	116
5.6.3	I/O Signal Wiring Examples	117
5.6.4	I/O Circuits	119
5.7	Connecting Safety Function Signals	120
5.7.1	Overview	120
5.7.2	Pin Arrangement of Safety Function Signals (CN8)	121
5.7.3	I/O Circuits	121

5.8	Connecting PROFINET Communications Cables.	124
5.8.1	Overview.	124
5.8.2	PROFINET Connectors (RJ45).	124
5.8.3	Ethernet Communications Cables.	125
5.9	Connecting the Other Connectors.	125
5.9.1	Serial Communications Connector (CN502).	125
5.9.2	Computer Connector (CN7).	126
5.9.3	Analog Monitor Connector (CN5).	126
6	Basic Functions That Require Setting before Operation.	127
6.1	Overview.	127
6.2	Manipulating SERVOPACK Parameters (Pn□□□).	127
6.2.1	Overview.	127
6.2.2	Classifications of SERVOPACK Parameters.	127
6.2.3	Notation for SERVOPACK Parameters.	128
6.2.4	Setting Methods for SERVOPACK Parameters.	129
6.2.5	Write Prohibition Setting for SERVOPACK Parameters.	131
6.2.6	Initializing SERVOPACK Parameter Settings.	136
6.3	Power Supply Type Settings for the Main Circuit and Control Circuit.	138
6.3.1	Overview.	138
6.3.2	AC Power Supply Input/DC Power Supply Input Setting.	138
6.3.3	Single-phase AC Power Supply Input/Three-phase AC Power Supply Input Setting.	139
6.4	Automatic Detection of Connected Motor.	140
6.5	Motor Direction Setting.	141
6.6	Setting the Linear Encoder Pitch.	142
6.7	Writing Linear Servomotor Parameters.	143
6.8	Selecting the Phase Sequence for a Linear Servomotor.	150
6.9	Polarity Sensor Setting.	152
6.10	Polarity Detection.	152
6.10.1	Overview.	152
6.10.2	Restrictions.	153
6.10.3	Using the Servo ON Command (Enable Operation Command) to Perform Polarity Detection.	154
6.10.4	Using a Tool Function to Perform Polarity Detection.	154
6.11	Overtravel and Related Settings.	155
6.11.1	Overview.	155
6.11.2	Overtravel Signals.	156
6.11.3	Setting to Enable/Disable Overtravel.	157
6.11.4	Motor Stopping Method for Overtravel.	157
6.11.5	Overtravel Warnings.	158
6.11.6	Overtravel Release Method Selection.	160
6.11.7	Overtravel Status.	161
6.11.8	Overtravel Operation by Mode.	161

6.12	Holding Brake.	161
6.12.1	Overview.	161
6.12.2	Brake Operating Sequence.	162
6.12.3	/BK (Brake) Signal.	163
6.12.4	Output Timing of /BK (Brake) Signal When the Servomotor Is Stopped.	164
6.12.5	Output Timing of /BK (Brake) Signal When the Servomotor Is Operating.	165
6.13	Motor Stopping Methods for Servo OFF and Alarms.	166
6.13.1	Overview.	166
6.13.2	Stopping Method for Servo OFF.	168
6.13.3	Servomotor Stopping Method for Alarms.	168
6.14	Motor Overload Detection Level.	170
6.14.1	Overview.	170
6.14.2	Detection Timing for Overload Warnings (A.910).	170
6.14.3	Detection Timing for Overload Alarms (A.720).	170
6.15	Setting Unit Systems.	171
6.15.1	Overview.	171
6.15.2	Setting the Position Reference Unit.	172
6.15.3	Setting the Speed Reference Unit.	177
6.15.4	Setting the Acceleration Reference Unit.	178
6.16	Resetting the Absolute Encoder.	179
6.16.1	Overview.	179
6.16.2	Precautions on Resetting.	180
6.16.3	Preparations.	180
6.16.4	Applicable Tools.	180
6.16.5	Operating Procedure.	180
6.17	Setting the Origin of the Absolute Encoder.	183
6.17.1	Absolute Encoder Origin Offset.	183
6.17.2	Setting the Origin of the Absolute Linear Encoder.	183
6.18	Setting the Regenerative Resistor Capacity.	187
7	Application Functions.	189
7.1	Overview.	189
7.2	I/O Signal Allocations.	189
7.2.1	Overview.	189
7.2.2	Input Signal Allocations.	189
7.2.3	Output Signal Allocations.	190
7.2.4	ALM (Servo Alarm) Signal.	192
7.2.5	/WARN (Warning) Signal.	192
7.2.6	/TGON (Rotation Detection) Signal.	193
7.2.7	/S-RDY (Servo Ready) Signal.	194
7.2.8	/V-CMP (Speed Coincidence Detection) Signal.	195
7.2.9	/COIN (Positioning Completion) Signal.	196

7.2.10	/NEAR (Near) Signal.	197
7.2.11	Speed Limit during Torque Control.	199
7.3	Operation for Momentary Power Interruptions.	200
7.4	SEMI F47 Function.	201
7.5	Setting the Motor Maximum Speed.	203
7.6	Encoder Divided Pulse Output.	204
7.6.1	Overview.	204
7.6.2	Encoder Divided Pulse Output Signals.	204
7.6.3	Setting for the Encoder Divided Pulse Output.	210
7.7	Software Limits.	212
7.8	Selecting Torque Limits.	212
7.8.1	Overview.	212
7.8.2	Internal Torque Limits.	213
7.8.3	External Torque Limits.	214
7.8.4	/CLT (Torque Limit Detection) Signal.	218
7.9	Absolute Encoders.	218
7.9.1	Overview.	218
7.9.2	Connecting an Absolute Encoder.	220
7.9.3	Structure of the Position Data of the Absolute Encoder.	220
7.9.4	Output Ports for the Position Data from the Absolute Encoder.	220
7.9.5	Reading the Position Data from the Absolute Encoder.	221
7.9.6	Transmission Specifications.	222
7.9.7	Calculating the Current Position in Machine Coordinates.	223
7.9.8	Multiturn Limit Setting.	224
7.9.9	Multiturn Limit Disagreement Alarm (A.CC0).	225
7.10	Absolute Linear Encoders.	229
7.10.1	Overview.	229
7.10.2	Connecting an Absolute Linear Encoder.	230
7.10.3	Structure of the Position Data of the Absolute Linear Encoder.	230
7.10.4	Output Ports for the Position Data from the Absolute Linear Encoder.	230
7.10.5	Reading the Position Data from the Absolute Linear Encoder.	231
7.10.6	Transmission Specifications.	232
7.10.7	Calculating the Current Position in Machine Coordinates.	232
7.11	Software Reset.	233
7.11.1	Overview.	233
7.11.2	Preparations.	234
7.11.3	Applicable Tools.	234
7.11.4	Operating Procedure.	234
7.12	Initializing the Vibration Detection Level.	236
7.12.1	Overview.	236
7.12.2	Preparations.	237
7.12.3	Applicable Tools.	237

7.12.4	Operating Procedure	237
7.12.5	Related Parameters	240
7.13	Adjusting the Motor Current Detection Signal Offset	241
7.13.1	Overview	241
7.13.2	Automatic Adjustment	241
7.13.3	Manual Adjustment	243
7.14	Forcing the Motor to Stop	245
7.14.1	Overview	245
7.14.2	FSTP (Forced Stop Input) Signal	246
7.14.3	Stopping Method Selection for Forced Stops	246
7.14.4	Resetting Method for Forced Stops	248
7.15	Overheat Protection	248
7.15.1	Overview	248
7.15.2	Connecting the Overheat Protection Input (TH) Signal	248
7.15.3	Overheat Protection Selections	249
8	Trial Operation and Actual Operation	251
8.1	Overview	251
8.2	Flow of Trial Operation	251
8.2.1	Flow of Trial Operation for Rotary Servomotors	251
8.2.2	Flow of Trial Operation for Linear Servomotors	252
8.3	Inspections and Confirmations before Trial Operation	255
8.4	Trial Operation for the Servomotor without a Load	255
8.4.1	Overview	255
8.4.2	Preparations	255
8.4.3	Applicable Tools	257
8.4.4	Operating Procedure	257
8.5	Trial Operation with PROFINET Communications	260
8.6	Trial Operation with the Servomotor Connected to the Machine	262
8.6.1	Overview	262
8.6.2	Precautions	262
8.6.3	Preparations	263
8.6.4	Operating Procedure	263
8.7	Convenient Function to Use during Trial Operation	264
8.7.1	Overview	264
8.7.2	Program Jogging	264
8.7.3	Origin Search	272
8.7.4	Test without a Motor	275

9	Tuning	282
9.1	Overview	282
9.2	Overview and Flow of Tuning	282
9.2.1	Overview	282
9.2.2	Tuning Functions	283
9.2.3	Diagnostic Tool	285
9.3	Monitoring Methods	285
9.4	Precautions to Ensure Safe Tuning	286
9.4.1	Overview	286
9.4.2	Overtravel Settings	286
9.4.3	Torque Limit Settings	287
9.4.4	Setting the Position Deviation Overflow Alarm Level	287
9.4.5	Vibration Detection Level Setting	289
9.4.6	Setting the Position Deviation Overflow Alarm Level at Servo ON	289
9.5	Tuning-less Function	290
9.5.1	Overview	290
9.5.2	Application Restrictions	290
9.5.3	Operating Procedure	291
9.5.4	Troubleshooting Alarms	293
9.5.5	Parameters Disabled by Tuning-less Function	293
9.5.6	Automatically Adjusted Function Setting	294
9.5.7	Related Parameters	294
9.6	Estimating the Moment of Inertia	295
9.6.1	Overview	295
9.6.2	Outline	295
9.6.3	Restrictions	295
9.6.4	Applicable Tools	296
9.6.5	Operating Procedure	296
9.7	Autotuning without Host Reference	306
9.7.1	Overview	306
9.7.2	Outline	307
9.7.3	Restrictions	308
9.7.4	Applicable Tools	309
9.7.5	Operating Procedure	309
9.7.6	Troubleshooting Problems in Autotuning without a Host Reference	316
9.7.7	Automatically Adjusted Function Settings	318
9.7.8	Related Parameters	321
9.8	Autotuning with a Host Reference	322
9.8.1	Overview	322
9.8.2	Outline	322
9.8.3	Restrictions	323
9.8.4	Applicable Tools	323

9.8.5	Operating Procedure.	324
9.8.6	Troubleshooting Problems in Autotuning with a Host Reference.	330
9.8.7	Automatically Adjusted Function Settings.	331
9.8.8	Related Parameters.	331
9.9	Custom Tuning.	332
9.9.1	Overview.	332
9.9.2	Outline.	332
9.9.3	Preparations.	332
9.9.4	Applicable Tools.	332
9.9.5	Operating Procedure.	333
9.9.6	Automatically Adjusted Function Settings.	345
9.9.7	Tuning Example for Tuning Mode 2 or 3.	345
9.9.8	Related Parameters.	346
9.10	Anti-Resonance Control Adjustment.	347
9.10.1	Overview.	347
9.10.2	Outline.	347
9.10.3	Preparations.	348
9.10.4	Applicable Tools.	348
9.10.5	Operating Procedure.	348
9.10.6	Related Parameters.	353
9.10.7	Suppressing Different Vibration Frequencies with Anti-resonance Control.	353
9.11	Vibration Suppression.	355
9.11.1	Overview.	355
9.11.2	Outline.	355
9.11.3	Preparations.	356
9.11.4	Applicable Tools.	357
9.11.5	Operating Procedure.	357
9.11.6	Setting Combined Functions.	360
9.11.7	Related Parameters.	361
9.12	Speed Ripple Compensation.	361
9.12.1	Overview.	361
9.12.2	Outline.	361
9.12.3	Setting Up Speed Ripple Compensation.	362
9.12.4	Setting Parameters.	368
9.13	Additional Adjustment Functions.	369
9.13.1	Overview.	369
9.13.2	Gain Switching.	370
9.13.3	Friction Compensation.	374
9.13.4	Gravity Compensation.	376
9.13.5	Current Control Mode Selection.	377
9.13.6	Current Gain Level Setting.	378
9.13.7	Speed Detection Method Selection.	378

9.13.8	Speed Feedback Filter.	379
9.13.9	Backlash Compensation.	379
9.14	Manual Tuning.	384
9.14.1	Overview.	384
9.14.2	Tuning the Servo Gains.	385
9.14.3	Compatible Adjustment Functions.	397
9.15	Diagnostic Tools.	402
9.15.1	Mechanical Analysis.	402
9.15.2	Easy FFT.	403
10	Monitoring.	410
10.1	Overview.	410
10.2	Monitoring Product Information.	410
10.2.1	Items That Can Be Monitored.	410
10.2.2	Operating Procedures.	410
10.3	Monitoring SERVOPACK Status.	411
10.3.1	Servo Drive Status.	411
10.3.2	Monitoring Status and Operations.	412
10.3.3	I/O Signal Monitor.	414
10.4	Monitoring Machine Operation Status and Signal Waveforms.	415
10.4.1	Overview.	415
10.4.2	Items That You Can Monitor.	415
10.4.3	Using the SigmaWin+.	416
10.4.4	Using the Analog Monitors.	418
10.5	Monitoring Product Life.	424
10.5.1	Items That You Can Monitor.	424
10.5.2	Operating Procedure.	425
10.5.3	Preventative Maintenance.	426
10.6	Alarm Tracing.	427
10.6.1	Overview.	427
10.6.2	Data for Which Alarm Tracing Is Performed.	428
10.6.3	Applicable Tools.	428
11	Fully-Closed Loop Control.	429
11.1	Overview.	429
11.2	Fully-Closed System.	429
11.3	SERVOPACK Commissioning Procedure.	430
11.4	Parameter and Object Settings for Fully-closed Loop Control.	431
11.4.1	Overview.	431
11.4.2	Control Block Diagram for Fully-Closed Loop Control.	432
11.4.3	Setting the Motor Direction and the Machine Movement Direction.	433
11.4.4	Setting the Number of External Encoder Scale Pitches.	434
11.4.5	Setting the PAO, PBO, and PCO (Encoder Divided Pulse Output) Signals.	434
11.4.6	External Absolute Encoder Data Reception Sequence.	435

11.4.7	Setting Unit Systems.	436
11.4.8	Alarm Detection Settings.	436
11.4.9	Analog Monitor Signal Settings.	437
11.4.10	Setting to Use an External Encoder for Speed Feedback.	437
11.5	Monitoring an External Encoder.	437
11.5.1	Overview.	437
11.5.2	Option Module Required for Monitoring.	438
11.5.3	Related Parameters.	438
11.5.4	Block Diagrams.	438
12	Safety Functions.	440
12.1	Overview.	440
12.2	Introduction to the Safety Functions.	440
12.2.1	Safety Functions.	440
12.2.2	Precautions for Safety Functions.	441
12.3	Hard Wire Base Block (HWBB and SBB).	441
12.3.1	Overview.	441
12.3.2	Risk Assessment.	442
12.3.3	Hard Wire Base Block (HWBB) State.	443
12.3.4	Resetting the HWBB State.	444
12.3.5	Recovery Method.	444
12.3.6	Detecting Errors in HWBB Signal.	445
12.3.7	HWBB Input Signal Specifications.	445
12.3.8	Operation without a Host Controller.	446
12.3.9	/S-RDY (Servo Ready Output) Signal.	446
12.3.10	/BK (Brake Output) Signal.	446
12.3.11	Stopping Methods.	447
12.3.12	ALM (Servo Alarm) Signal.	447
12.4	EDM1 (External Device Monitor).	447
12.4.1	Overview.	447
12.4.2	EDM1 Output Signal Specifications.	448
12.5	Applications Examples for Safety Functions.	448
12.5.1	Overview.	448
12.5.2	Connection Example.	448
12.5.3	Failure Detection Method.	449
12.5.4	Procedure.	450
12.6	Validating Safety Functions.	450
12.7	Connecting a Safety Function Device.	450
12.8	Safety Module Safety Functions.	451
12.8.1	Overview.	451
12.8.2	Safety Base Block with Delay (SBB-D).	451
12.8.3	Safe Position Monitor with Delay (SPM-D).	452

12.8.4	Safe Speed Limit with Delay (SLS-D)	453
12.8.5	Active Mode Function	454
13	PROFINET Communication	458
13.1	General	458
13.2	PROFINET Slave Information	458
13.3	Application and Communication Relationship (AR, CR)	459
13.4	Drive Units (DU) and Drive Objects (DO)	459
13.5	Identification and Maintenance Function (I&M)	461
13.6	Telegrams	464
13.6.1	Supported Telegrams	464
13.6.2	Standard Speed Telegram (ST1)	464
13.6.3	Standard Speed Telegram (ST2)	465
13.6.4	Standard Position Telegram (ST7)	465
13.6.5	Standard Position Telegram (ST9)	466
13.6.6	YASKAWA Telegram (Telegram 100)	467
13.6.7	Free Configurable Telegram (Telegram 999)	468
13.7	IO Data Signals	470
14	PROFIdrive Drive Profile	472
14.1	Device Control	472
14.2	Modes of Operation	474
14.3	PROFIdrive Position Mode	474
14.3.1	Overview	474
14.3.2	MDI Submode	477
14.3.3	Program Submode	479
14.3.4	Modulo Positioning	481
14.4	Homing Function	483
14.5	PROFIdrive Velocity Mode	485
14.6	Profile Torque Mode	487
14.7	Torque Limits	487
14.8	Digital Inputs and Outputs	488
14.9	Touch Probe Function	489
14.10	Fully-closed Loop Control	491
14.11	Get/Set SERVOPACK Parameter Functionality	492
15	Object Dictionary	493
15.1	Overview	493
15.2	Object Dictionary List	493
15.3	General Objects	498
15.4	Communication Objects	503
15.5	Manufacturer Specific Objects	507
15.6	Device Control	512
15.7	PROFIdrive Position Mode	523
15.8	Homing Function	531

15.9	Position Control Function.	534
15.10	PROFIdrive Velocity Mode.	536
15.11	Profile Torque Mode.	539
15.12	Touch Probe Function.	541
15.13	Digital Inputs/Outputs.	544
16	Maintenance.	546
16.1	Overview.	546
16.2	Inspections and Part Replacement.	546
16.2.1	Overview.	546
16.2.2	Inspections.	546
16.2.3	Guidelines for Part Replacement.	546
16.2.4	Replacing the Battery.	547
16.3	PROFINET Alarm Mechanism.	549
16.3.1	General.	549
16.3.2	PROFINET Alarm Structure.	549
16.3.3	Fault Buffer Mechanism.	550
16.4	Alarm Displays.	551
16.4.1	Overview.	551
16.4.2	List of Alarms.	552
16.4.3	Troubleshooting Alarms.	560
16.4.4	Resetting Alarms.	594
16.4.5	Displaying the Alarm History.	594
16.4.6	Clearing the Alarm History.	596
16.4.7	Resetting Alarms Detected in Option Modules.	597
16.4.8	Resetting Motor Type Alarms.	599
16.5	Warning Displays.	600
16.5.1	General.	600
16.5.2	List of Warnings.	601
16.5.3	Troubleshooting Warnings.	603
16.6	Troubleshooting Based on the Operation and Conditions of the Servomotor.	609
17	Parameter and Object Lists.	622
17.1	Overview.	622
17.2	List of Parameters.	622
17.2.1	Interpreting the Parameter Lists.	622
17.2.2	List of Parameters.	623
17.3	Object List.	681
17.4	PROFINET Parameter Request Error Codes.	697
17.5	Parameter Recording Table.	699

18	Appendices	707
18.1	Overview	707
18.2	Interpreting Panel Displays	707
18.2.1	Overview	707
18.2.2	Interpreting Status Displays	707
18.2.3	Alarm and Warning Displays	707
18.2.4	Hard Wire Base Block Active Display	707
18.2.5	Overtravel Display	708
18.2.6	Forced Stop Display	708
18.2.7	PROFINET Communications Indicators	708
18.3	Corresponding SERVOPACK and SigmaWin+ Function Names	709
18.3.1	Overview	709
18.3.2	Corresponding SERVOPACK Utility Function Names	709
18.3.3	Corresponding SERVOPACK Monitor Display Function Names	710
19	Revision history	714

1 General

1.1 About this Manual

This manual provides information required to select Σ -7S SERVOPACKs with PROFINET Communications References for Σ -7-Series AC Servo Drives, and to design, perform trial operation of, tune, operate, and maintain the Servo Drives.

Read and understand this manual to ensure correct usage of the Σ -7-Series AC Servo Drives.

Keep this manual in a safe place so that it can be referred to whenever necessary.

1.2 Outline of Manual

The contents of the chapters of this manual are described in the following table.

Refer to these chapters as required.

Chapter	Chapter Title	Contents
1	Basic Information on SERVOPACKs	Provides information required to select SERVOPACKs, such as SERVOPACK models and combinations with Servomotors.
2	Selecting a SERVOPACK	Provides information required to select SERVOPACKs, such as specifications, block diagrams, dimensional drawings, and connection examples.
3	SERVOPACK Installation	Provides information on installing SERVOPACKs in the required locations.
4	Wiring and Connecting SERVOPACKs	Provides information on wiring and connecting SERVOPACKs to power supplies and peripheral devices.
5	Basic Functions That Require Setting before Operation	Describes the basic functions that must be set before you start Servo System operation. It also describes the setting methods.
6	Application Functions	Describes the application functions that you can set before you start Servo System operation. It also describes the setting methods.
7	Trial Operation and Actual Operation	Provides information on the flow and procedures for trial operation and convenient functions to use during trial operation.
8	Tuning	Provides information on the flow of tuning, details on tuning functions, and related operating procedures.
9	Monitoring	Provides information on monitoring SERVOPACK product information and SERVOPACK status.
10	Fully-Closed Loop Control	Provides detailed information on performing fully-closed loop control with the SERVOPACK.
11	Safety Functions	Provides detailed information on the safety functions of the SERVOPACK.
12	PROFINET Communications	Provides basic information on PROFINET communications.

Chapter	Chapter Title	Contents
13	PROFIdrive Drive Profile	Provides detailed information on the PROFIdrive drive profile.
14	Object Dictionary	Provides an overview and details on the object dictionary.
15	Maintenance	Provides information on the meaning of, causes of, and corrections for alarms and warnings.
16	Parameter and Object Lists	Provides information on parameters and objects.
17	Appendices	Provides information on interpreting panel displays and tables of corresponding SERVOPACK and SigmaWin+ function names.

1.3 Related Documents

The relationships between the documents that are related to the Servo Drives are shown in the following figure. The numbers in the figure correspond to the numbers in the table on the following pages. Refer to these documents as required.

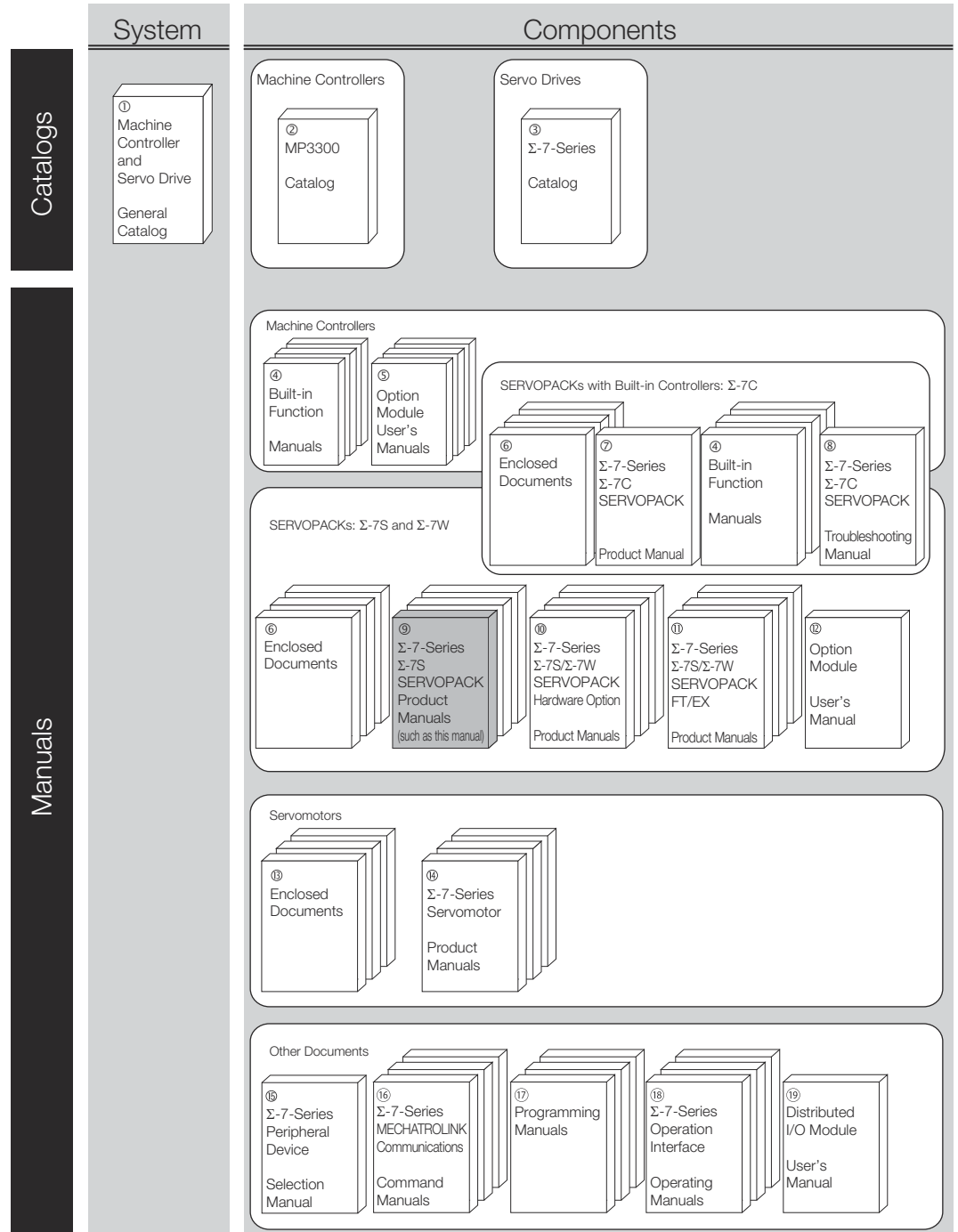


Fig. 1: Related Documents Sigma 7 Series

Classification	Document Name	Document No.	Description
1 Machine Controller and Servo Drive General Catalog	Machine Controller and AC Servo Drive Solutions Catalog	KAEP S80001 22	Describes the features and application examples for combinations of MP3000-Series Machine Controllers and Σ -7-Series AC Servo Drives.

Classification	Document Name	Document No.	Description
2 MP3300 Catalog	Machine Controller MP3300	KAEP C880725 03	Provides detailed information on MP3300 Machine Controllers, including features and specifications.
3 Σ -7-Series Catalog	AC Servo Drives Σ -7 Series	KAEP S800001 23	Provides detailed information on Σ - 7-Series AC Servo Drives, including features and specifications.
4 Built-in Function Manuals	Σ -7-Series AC Servo Drive Σ -7C SERVOPACK Motion Control User's Manual	SIEP S800002 03	Provides detailed information on the specifications, system configuration, and application methods of the Motion Control Function Modules (SVD, SVC4, and SVR4) for Σ - 7-Series Σ -7C SERVOPACKs.
	Machine Controller MP3000 Series Communications User's Manual	SIEP C880725 12	Provides detailed information on the specifications, system configuration, and communications connection methods for the Ethernet communications that are used with MP3000-Series Machine Controllers and Σ -7-Series Σ -7C SERVOPACKs.
5 Option Module User's Manuals	Machine Controller MP2000 Series Communication Module User's Manual	SIEP C880700 04	Provide detailed information on the specifications and communications methods for the Communications Modules that can be mounted to MP3000-Series Machine Controllers and Σ -7-Series Σ -7C SERVOPACKs.
	Machine Controller MP2000 Series 262IF-01 FL-net Communication Module User's Manual	SIEP C880700 36	
	Machine Controller MP2000 Series 263IF-01 EtherNet/IP Communication Module User's Manual	SIEP C880700 39	
	Machine Controller MP2000 Series I/O Module User's Manual	SIEP C880700 34	Provide detailed information on the specifications and communications methods for the I/O Modules that can be mounted to MP3000-Series Machine Controllers and Σ -7-Series Σ -7C SERVOPACKs.
	Machine Controller MP2000 Series Analog Input/Analog Output Module AI-01/AO-01 User's Manual	SIEP C880700 26	
	Machine Controller MP2000 Series Counter Module CNTR-01 User's Manual	SIEP C880700 27	
6 Enclosed Documents	Σ -7-Series AC Servo Drive Σ -7S and Σ -7W SERVOPACK Safety Precautions	TOMP C710828 00	Provides detailed information for the safe usage of Σ -7-Series SERVOPACKs.
	Σ -V-Series/ Σ -V-Series for Large-Capacity Models/ Σ -7-Series Safety Precautions Option Module	TOBP C720829 00	Provides detailed information for the safe usage of Option Modules.
	Σ -V-Series/ Σ -V-Series for Large-Capacity Models/ Σ -7-Series Installation Guide Command Option Module	TOBP C720829 01	Provides detailed procedures for installing the Command Option Module in a SERVOPACK.

Related Documents

Classification	Document Name	Document No.	Description
	Σ -V-Series/ Σ -V-Series for Large-Capacity Models/ Σ -7-Series Installation Guide Fully-closed Module	TOBP C720829 03	Provides detailed procedures for installing the Fully-closed Module in a SERVOPACK.
	Σ -V-Series/ Σ -V-Series for Large-Capacity Models/ Σ -7-Series Installation Guide Safety Module	TOBP C720829 06	Provides detailed procedures for installing the Safety Module in a SERVOPACK.
	Σ -V-Series/ Σ -V-Series for Large-Capacity Models/ Σ -7-Series Installation Guide INDEXER Module	TOBP C720829 02	Provides detailed procedures for installing the INDEXER Module in a SERVOPACK.
	Σ -V-Series/ Σ -V-Series for Large-Capacity Models/ Σ -7-Series Installation Guide DeviceNet Module	TOBP C720829 07	Provides detailed procedures for installing the DeviceNet Module in a SERVOPACK.
7 Σ -7-Series Σ -7C SERVOPACK Product Manual	Σ -7-Series AC Servo Drive Σ -7C SERVOPACK Product Manual	SIEP S800002 04	Provides detailed information on selecting Σ -7-Series Σ -7C SERVOPACKs; installing, connecting, setting, testing in trial operation, and tuning Servo Drives; writing, monitoring, and maintaining programs; and other information.
8 Σ -7-Series Σ -7C SERVOPACK Troubleshooting Manual	Σ -7-Series AC Servo Drive Σ -7C SERVOPACK Troubleshooting Manual	SIEP S800002 07	Provides detailed troubleshooting information for Σ -7-Series Σ -7C SERVOPACKs.
9 Σ -7-Series Σ -7S SERVOPACK Product Manuals	Σ -7-Series AC Servo Drive Σ -7S SERVOPACK Command Option Attachable Type with INDEXER Module Product Manual	SIEP S800001 64	Provide detailed information on selecting Σ -7-Series SERVOPACKs and information on installing, connecting, setting, performing trial operation for, tuning, monitoring, and maintaining the Servo Drives.
	Σ -7-Series AC Servo Drive Σ -7S SERVOPACK Command Option Attachable Type with DeviceNet Module Product Manual	SIEP S800001 70	
	Σ -7-Series AC Servo Drive Σ -7S SERVOPACK with PROFINET Communications References Product Manual	This manual (SIEP YEUOC7P 02)	
10 Σ -7-Series Σ -7S/ Σ -7W SERVOPACK with Hardware Option Specifications Product Manuals	Σ -7-Series AC Servo Drive Σ -7S/ Σ -7W SERVOPACK with Hardware Option Specifications Dynamic Brake Product Manual	SIEP S800001 73	Provide detailed information on Hardware Options for Σ -7-Series SERVOPACKs.
	Σ -7-Series AC Servo Drive Σ -7W/ Σ -7C SERVOPACK with Hardware Option Specifications HWBB Function Product Manual	SIEP S800001 72	
11 Σ -7-Series Σ -7S/ Σ -7W SERVOPACK FT/EX Product Manuals	Σ -7-Series AC Servo Drive Σ -7S SERVOPACK with FT/EX Specification for Indexing Application Product Manual	SIEP S800001 84	Provide detailed information on the FT/EX Option for Σ -7-Series SERVOPACKs.
	Σ -7-Series AC Servo Drive Σ -7S SERVOPACK with FT/EX Specification for Tracking Application Product Manual	SIEP S800001 89	

Classification	Document Name	Document No.	Description
	Σ -7-Series AC Servo Drive Σ -7S SERVOPACK with FT/EX Specification for Application with Special Motor, SGM7D Motor Product Manual	SIEP S800001 91	
	Σ -7-Series AC Servo Drive Σ -7S SERVOPACK with FT/EX Specification for Press and Injection Molding Application Product Manual	SIEP S800001 94	
	Σ -7-Series AC Servo Drive Σ -7S SERVOPACK with FT/EX Specification for Transfer and Alignment Application Product Manual	SIEP S800001 95	
	Σ -7-Series AC Servo Drive Σ -7S SERVOPACK with FT/EX Specification for Torque/Force Assistance for Conveyance Application Product Manual	SIEP S800002 09	
	Σ -7-Series AC Servo Drive Σ -7S SERVOPACK with FT/EX Specification for Cutting Application Feed Shaft Motor Product Manual	SIEP S800002 10	
12 Option Module User's Manual	AC Servo Drives Σ -V Series/ Σ -V Series for Large-Capacity Models/ Σ -7 Series User's Manual Safety Module	SIEP C720829 06	Provides details information required for the design and maintenance of a Safety Module.
13 Enclosed Documents	AC Servo Drive Rotary Servomotor Safety Precautions	TOBP C230260 00	Provides detailed information for the safe usage of Rotary Servomotors and Direct Drive Servomotors.
	AC Servomotor Linear Σ Series Safety Precautions	TOBP C230800 00	Provides detailed information for the safe usage of Linear Servomotors.
14 Σ -7-Series Servomotor Product Manuals	Σ -7-Series AC Servo Drive Rotary Servomotor Product Manual	SIEP S800001 36	Provide detailed information on selecting, installing, and connecting the Σ -7-Series Servomotors.
	Σ -7-Series AC Servo Drive Linear Servomotor Product Manual	SIEP S800001 37	
	Σ -7-Series AC Servo Drive Direct Drive Servomotor Product Manual	SIEP S800001 38	
15 Σ -7-Series Peripheral Device Selection Manual	Σ -7-Series AC Servo Drive Peripheral Device Selection Manual	SIEP S800001 32	Provides the following information in detail for Σ -7-Series Servo Systems. <ul style="list-style-type: none"> ■ Cables: Models, dimensions, wiring materials, connector models, and connection specifications ■ Peripheral devices: Models, specifications, diagrams, and selection (calculation) methods

Related Documents

Classification	Document Name	Document No.	Description
16 Σ-7-Series MECHATROLINK Communications Command Manuals	Σ-7-Series AC Servo Drive MECHATROLINK-II Communica- tions Command Manual	SIEP S800001 30	Provides detailed information on the MECHATROLINK-II communi- cations commands that are used for a Σ-7-Series Servo System.
	Σ-7-Series AC Servo Drive MECHATROLINK-III Communica- tions Standard Servo Profile Com- mand Manual	SIEP S800001 31	Provides detailed information on the MECHATROLINK-III commu- nications standard servo profile commands that are used for a Σ-7- Series Servo System.
17 Programming Man- uals	Machine Controller MP3000 Series Ladder Programming Manual	SIEP C880725 13	Provides detailed information on the ladder programming specifica- tions and instructions for MP3000- Series Machine Controllers and Σ- 7-Series Σ-7C SERVOPACKs.
	Machine Controller MP3000 Series Motion Programming Manual	SIEP C880725 14	Provides detailed information on the motion programming and sequence programming specifica- tions and instructions for MP3000- Series Machine Controllers and Σ- 7-Series Σ-7C SERVOPACKs.
18 Σ-7-Series Operation Interface Operating Manuals	Machine Controller MP2000/ MP3000 Series Engineering Tool MPE720 Version 7 User's Manual	SIEP C880761 03	Describes in detail how to operate MPE720 version 7.
	Σ-7-Series AC Servo Drive Digital Operator Operating Manual	SIEP S800001 33	Describes the operating proce- dures for a Digital Operator for a Σ-7-Series Servo System.
	AC Servo Drive Engineering Tool SigmaWin+ Operation Manual	SIET S800001 34	Provides detailed operating pro- cedures for the SigmaWin+ Engi- neering Tool for a Σ-7-Series Servo System.
19 Distributed I/O Module User's Manual	MECHATROLINK-III Compatible I/O Module User's Manual	SIEP C880781 04	Describes the functions, spec- ifications, operating methods, and MECHATROLINK-III commu- nications for the Remote I/O Modules for MP2000/MP3000- Series Machine Controllers.

1.4 Using This Manual

Technical Terms and Abbreviations Used in This Manual

The following tables show the meaning of the terms and abbreviations used in this manual.

General SERVOPACK-related Terms

Term	Meaning
Servomotor	A Σ -7-Series Rotary Servomotor, Direct Drive Servomotor, or Linear Servomotor.
Rotary Servomotor	A generic term used for a Σ -7-Series Rotary Servomotor (SGMMV, SGM7J, SGM7A, SGM7P, or SGM7G) or a Direct Drive Servomotor (SGM7E, SGM7F, SGM7C, or SGM7S). The descriptions will specify when Direct Drive Servomotors are excluded.
Direct Drive Servomotor	A Σ -7-Series Direct Drive Servomotor (SGM7E, SGM7F, SGM7C, or SGM7S).
Linear Servomotor	A Σ -7-Series Linear Servomotor (SGLG, SGLF, or SGLT).
SERVOPACK	A Σ -7-Series Σ -7S Servo Amplifier with PROFINET Communications References.
Servo Drive	The combination of a Servomotor and SERVOPACK.
Servo System	A servo control system that includes the combination of a Servo Drive with a host controller and peripheral devices.
Servo ON	Supplying power to the motor.
Servo OFF	Not supplying power to the motor.
Servo ON command (Enable Operation command)	A command that is used to turn ON the servo (i.e., supply power to the motor) when bit 3 of controlword (6040h) is changed to 1 (ON) while the control power supply and main circuit power supply are ON.
Servo OFF command (Disable Operation command)	A command that is used to turn OFF the servo (i.e., power not supplied to the motor) when bit 3 of controlword (6040h) is changed to 0 (OFF) while the control power supply and main circuit power supply are ON.
Base block (BB)	Shutting OFF the power supply to the motor by shutting OFF the base current to the power transistor in the SERVOPACK.
Servo Lock	A state in which the motor is stopped and is in a position loop with a position reference of 0.
Main Circuit Cable	One of the cables that connect to the main circuit terminals, including the Main Circuit Power Supply Cable, Control Power Supply Cable, and Servomotor Main Circuit Cable.
SigmaWin+	The Engineering Tool for setting up and tuning Servo Drives or a computer in which the Engineering Tool is installed.

PROFINET-related Terms

Term	Description
Acyclic communication	Communication in which messages are sent only once on request.
Array	Parameter consisting of data fields of equal data type.

Term	Description
Cyclic communication	Communication in which parameter/process data objects are sent cyclically at pre-defined intervals.
DCP	Discovery Control Protocol. A protocol that allows the IO-Controller to find every PROFINET IO-Device on a subnet.
Fault	Event that leads to tripping of the device.
GSDML file	XML-based device description files in a specified form. Each different IO-Device type on the PROFINET IO network needs to have its own GSDML file.
Index	Access reference for objects in PROFINET IO. 'PNU' is the PROFINET designation for index.
IO-Controller	Control system with bus initiative. In PROFINET IO terminology, IO-Controllers are also called master stations or active stations.
IO-Device	Subordinated bus participant. In PROFINET IO terminology, IO-Devices are also called passive stations or nodes.
Name	Symbolic name of a parameter.
Parameter	Value that can be accessed as an object, eg, variable, constant, signal.
Parameter number	Parameter address
Process data	Data that contains Control word and reference value or Status word and actual value. May also contain other (user-defined) control information.
Warning	Signal caused by an existing alarm which does not lead to tripping of the device.

PROFINET-related Abbreviations

Abbreviation	Description
DAP	Device access point
DO	Drive Object
DU	Drive Unit
GSDML	General Station Description Markup Language
IRT	Isochronous Real-Time
MAP	Module access point
PAP	Parameter access point
PNU	Parameter number
PZD	Process data
PZDO	Process data object
RT	Real-Time
RPZD	Received Process data
STW	Control word
TPZD	Transmitted Process data
ZSW	Status word

Differences in Terms for Rotary Servomotors and Linear Servomotors

There are differences in the terms that are used for Rotary Servomotors and Linear Servomotors.

This manual primarily describes Rotary Servomotors. If you are using a Linear Servomotor, you need to interpret the terms as given in the following table.

Rotary Servomotors	Linear Servomotors
torque	force
moment of inertia	mass
rotation	movement
forward rotation and reverse rotation	forward movement and reverse movement
CW and CCW pulse trains	forward and reverse pulse trains
rotary encoder	linear encoder
absolute rotary encoder	absolute linear encoder
incremental rotary encoder	incremental linear encoder
unit: min ⁻¹	unit: mm/s
unit: Nm	unit: N

Notation Used in this Manual

■ Notation for Reverse Signals

The names of reverse signals (i.e., ones that are valid when low) are written with a forward slash (/) before the signal abbreviation.

Notation Example: \overline{BK} is written as /BK.

■ Notation for Parameters

The notation depends on whether the parameter requires a numeric setting (parameter for numeric setting) or requires the selection of a function (parameter for selecting functions).

Parameters for Numeric Settings

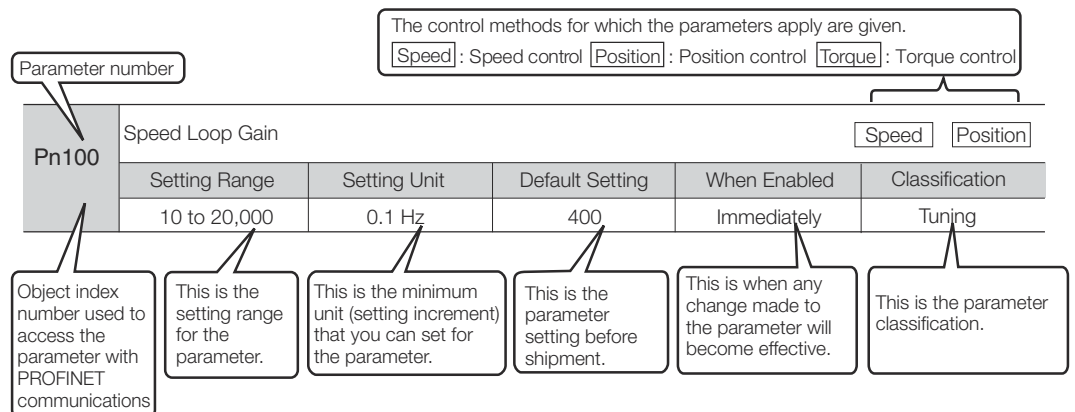


Fig. 2: Notation for Parameters - Numeric Settings

Parameters for Selecting Functions

Parameter	Meaning	When Enabled	Classification
Pn002	n.□0□□ (default setting)	After restart	Setup
	n.□1□□		
	n.□2□□		

Parameter number

This is when any change made to the parameter will become effective.

This is the parameter classification.

Object index number used to access the parameter with PROFINET communications

The notation "n.□□□□" indicates a parameter for selecting functions. Each □ indicates the setting for one digit. The notation shown here means that the third digit from the right is set to 2.

This column explains the selections for the function.

Fig. 3: Notation for Parameters - Selecting Functions

Notation Example

Notation Examples for Pn002

Notation	Digit Notation		Numeric Value Notation	
	Notation	Meaning	Notation	Meaning
Pn002 = n.□□□X	Pn002 = n.□□□X	Indicates the first digit from the right in Pn002.	Pn002 = n.□□□1	Indicates that the first digit from the right in Pn002 is set to 1.
Pn002 = n.□□X□	Pn002 = n.□□X□	Indicates the second digit from the right in Pn002.	Pn002 = n.□□1□	Indicates that the second digit from the right in Pn002 is set to 1.
Pn002 = n.□X□□	Pn002 = n.□X□□	Indicates the third digit from the right in Pn002.	Pn002 = n.□1□□	Indicates that the third digit from the right in Pn002 is set to 1.
Pn002 = n.X□□□	Pn002 = n.X□□□	Indicates the fourth digit from the right in Pn002.	Pn002 = n.1□□□	Indicates that the fourth digit from the right in Pn002 is set to 1.

n . 0 0 0 0

Fig. 4: Notation Example

Engineering Tools Used in This Manual

This manual uses the interfaces of the SigmaWin+ for descriptions.

Trademarks

- PROFINET is a registered trademark of PROFIBUS and PROFINET International (PI).
- QR code is a trademark of Denso Wave Inc.
- Other product names and company names are the trademarks or registered trademarks of the respective company. "TM" and the © mark do not appear with product or company names in this manual.

1.5 Safety Precautions

1.5.1 Safety Information

To prevent personal injury and equipment damage in advance, the following signal words are used to indicate safety precautions in this document. The signal words are used to classify the hazards and the degree of damage or injury that may occur if a product is used incorrectly. Information marked as shown below is important for safety. Always read this information and heed the precautions that are provided.



DANGER

Indicates precautions that, if not heeded, are likely to result in loss of life, serious injury, or fire.



WARNING

Indicates precautions that, if not heeded, could result in loss of life, serious injury, or fire.



CAUTION

Indicates precautions that, if not heeded, could result in relatively serious or minor injury, or in fire.



NOTICE

Indicates precautions that, if not heeded, could result in property damage.

1.5.2 Safety Precautions That Must Always Be Observed

General Precautions



DANGER

- Read and understand this manual to ensure the safe usage of the product.
- Keep this manual in a safe, convenient place so that it can be referred to whenever necessary. Make sure that it is delivered to the final user of the product.
- Do not remove covers, cables, connectors, or optional devices while power is being supplied to the SERVOPACK.
There is a risk of electric shock, operational failure of the product, or burning.



WARNING

- Use a power supply with specifications (number of phases, voltage, frequency, and AC/DC type) that are appropriate for the product.
There is a risk of burning, electric shock, or fire.
- Connect the ground terminals on the SERVOPACK and Servomotor to ground poles according to local electrical codes (100 Ω or less for a SERVOPACK with a 100-VAC or 200-VAC power supply, and 10 Ω or less for a SERVOPACK with a 400-VAC power supply).
There is a risk of electric shock or fire.
- Do not attempt to disassemble, repair, or modify the product.
There is a risk of fire or failure. The warranty is void for the product if you disassemble, repair, or modify it.

**CAUTION**

- The SERVOPACK heat sinks, Regenerative Resistors, Servomotors, and other components can be very hot while power is ON or soon after the power is turned OFF. Implement safety measures, such as installing covers, so that hands and parts such as cables do not come into contact with hot components.

There is a risk of burn injury.

- For a 24-VDC power supply, use a power supply device with double insulation or reinforced insulation.
- Do not damage, pull on, apply excessive force to, place heavy objects on, or pinch cables.

There is a risk of electric shock.

- The person who designs the system that uses the hard wire base block safety function must have a complete knowledge of the related safety standards and a complete understanding of the instructions in this document.

There is a risk of injury, product damage, or machine damage.

- Do not use the product in an environment that is subject to water, corrosive gases, or flammable gases, or near flammable materials.

There is a risk of electric shock or fire.

**NOTICE**

- Do not attempt to use a SERVOPACK or Servomotor that is damaged or that has missing parts.
- Install external emergency stop circuits that shut OFF the power supply and stops operation immediately when an error occurs.
- In locations with poor power supply conditions, install the necessary protective devices (such as AC Reactors) to ensure that the input power is supplied within the specified voltage range.

There is a risk of damage to the SERVOPACK.

- Use a Noise Filter to minimize the effects of electromagnetic interference. Electronic devices used near the SERVOPACK may be affected by electromagnetic interference.
- Always use a Servomotor and SERVOPACK in one of the specified combinations.
- Do not touch a SERVOPACK or Servomotor with wet hands.

There is a risk of product failure.

Storage Precautions**CAUTION**

Do not place an excessive load on the product during storage. (Follow all instructions on the packages.)

There is a risk of injury or damage.

**NOTICE**

Do not install or store the product in any of the following locations.

- Locations that are subject to direct sunlight
- Locations that are subject to ambient temperatures that exceed product specifications
- Locations that are subject to relative humidities that exceed product specifications
- Locations that are subject to condensation as the result of extreme changes in temperature
- Locations that are subject to corrosive or flammable gases
- Locations that are near flammable materials
- Locations that are subject to dust, salts, or iron powder
- Locations that are subject to water, oil, or chemicals
- Locations that are subject to vibration or shock that exceeds product specifications
- Locations that are subject to radiation

If you store or install the product in any of the above locations, the product may fail or be damaged.

Transportation Precautions**CAUTION**

- **Transport the product in a way that is suitable to the mass of the product.**
- **Do not use the eyebolts on a SERVOPACK or Servomotor to move the machine.**
There is a risk of damage or injury.
- **When you handle a SERVOPACK or Servomotor, be careful of sharp parts, such as the corners.**
There is a risk of injury.
- **Do not place an excessive load on the product during transportation. (Follow all instructions on the packages.)**
There is a risk of injury or damage.

**NOTICE**

- **Do not hold onto the front cover or connectors when you move a SERVOPACK.**

There is a risk of the SERVOPACK falling.

- **A SERVOPACK or Servomotor is a precision device. Do not drop it or subject it to strong shock.**

There is a risk of failure or damage.

- **Do not subject connectors to shock.**

There is a risk of faulty connections or damage.

- **If disinfectants or insecticides must be used to treat packing materials such as wooden frames, plywood, or pallets, the packing materials must be treated before the product is packaged, and methods other than fumigation must be used.**

Example: Heat treatment, where materials are kiln-dried to a core temperature of 56°C for 30 minutes or more.

If the electronic products, which include stand-alone products and products installed in machines, are packed with fumigated wooden materials, the electrical components may be greatly damaged by the gases or fumes resulting from the fumigation process. In particular, disinfectants containing halogen, which includes chlorine, fluorine, bromine, or iodine can contribute to the erosion of the capacitors.

- **Do not overtighten the eyebolts on a SERVOPACK or Servomotor.**

If you use a tool to overtighten the eyebolts, the tapped holes may be damaged.

Installation Precautions**CAUTION**

- **Install the Servomotor or SERVOPACK in a way that will support the mass given in technical documents.**

- **Install SERVOPACKs, Servomotors, and Regenerative Resistors on non-flammable materials.**

Installation directly onto or near flammable materials may result in fire.

- **Provide the specified clearances between the SERVOPACK and the control panel as well as with other devices.**

There is a risk of fire or failure.

- **Install the SERVOPACK in the specified orientation.**

There is a risk of fire or failure.

- **Do not step on or place a heavy object on the product.**

There is a risk of failure, damage, or injury.

- **Do not allow any foreign matter to enter the SERVOPACK or Servomotor.**

There is a risk of failure or fire.

**NOTICE**

- **Do not install or store the product in any of the following locations.**
 - Locations that are subject to direct sunlight
 - Locations that are subject to ambient temperatures that exceed product specifications
 - Locations that are subject to relative humidities that exceed product specifications
 - Locations that are subject to condensation as the result of extreme changes in temperature
 - Locations that are subject to corrosive or flammable gases
 - Locations that are near flammable materials
 - Locations that are subject to dust, salts, or iron powder
 - Locations that are subject to water, oil, or chemicals
 - Locations that are subject to vibration or shock that exceeds product specifications
 - Locations that are subject to radiation

If you store or install the product in any of the above locations, the product may fail or be damaged.

- **Use the product in an environment that is appropriate for the product specifications.**

If you use the product in an environment that exceeds product specifications, the product may fail or be damaged.

- **A SERVOPACK or Servomotor is a precision device. Do not drop it or subject it to strong shock.**

There is a risk of failure or damage.

- **Always install a SERVOPACK in a control panel.**

- **Do not allow any foreign matter to enter a SERVOPACK or a Servomotor with a Cooling Fan and do not cover the outlet from the Servomotor's cooling fan.**

There is a risk of failure.

Wiring Precautions**DANGER**

Do not change any wiring while power is being supplied.

There is a risk of electric shock or injury.

**WARNING**

- **Wiring and inspections must be performed only by qualified engineers.**
There is a risk of electric shock or product failure.
- **Check all wiring and power supplies carefully.**
Incorrect wiring or incorrect voltage application to the output circuits may cause short-circuit failures. If a short-circuit failure occurs as a result of any of these causes, the holding brake will not work. This could damage the machine or cause an accident that may result in death or injury.
- **Connect the AC and DC power supplies to the specified SERVOPACK terminals.**
 - Connect an AC power supply to the L1, L2, and L3 terminals and the L1C and L2C terminals on the SERVOPACK.
 - Connect a DC power supply to the B1/⊕ and ⊖2 terminals and the L1C and L2C terminals on the SERVOPACK.

There is a risk of failure or fire.
- **If you use a SERVOPACK with the Dynamic Brake Hardware Option, connect an External Dynamic Brake Resistor that is suitable for the machine and equipment specifications to the specified terminals.**
There is a risk of unexpected operation, machine damage, burning, or injury when an emergency stop is performed.

**CAUTION**

- **Wait for at least six minutes after turning OFF the power supply (with a SERVOPACK for a 100-VAC power supply input, wait for at least nine minutes) and then make sure that the CHARGE indicator is not lit before starting wiring or inspection work. Do not touch the power supply terminals while the CHARGE lamp is lit after turning OFF the power supply because high voltage may still remain in the SERVOPACK.**
There is a risk of electric shock.
- **Observe the precautions and instructions for wiring and trial operation precisely as described in this document.**
Failures caused by incorrect wiring or incorrect voltage application in the brake circuit may cause the SERVOPACK to fail, damage the equipment, or cause an accident resulting in death or injury.
- **Check the wiring to be sure it has been performed correctly.**
Connectors and pin layouts are sometimes different for different models. Always confirm the pin layouts in technical documents for your model before operation.
There is a risk of failure or malfunction.
- **Connect wires to power supply terminals and motor connection terminals securely with the specified methods and tightening torque.**
Insufficient tightening may cause wires and terminal blocks to generate heat due to faulty contact, possibly resulting in fire.
- **Use shielded twisted-pair cables or screened unshielded multi-twisted-pair cables for I/O Signal Cables and Encoder Cables.**
- **Observe the following precautions when wiring the SERVOPACK's main circuit terminals.**
 - Turn ON the power supply to the SERVOPACK only after all wiring, including the main circuit terminals, has been completed.
 - If a connector is used for the main circuit terminals, remove the main circuit connector from the SERVOPACK before you wire it.

- Insert only one wire per insertion hole in the main circuit terminals.
- When you insert a wire, make sure that the conductor wire (e.g., whiskers) does not come into contact with adjacent wires.
- **Install molded-case circuit breakers and other safety measures to provide protection against short circuits in external wiring.**

There is a risk of fire or failure.



NOTICE

- **Whenever possible, use the Cables specified by Yaskawa.**
If you use any other cables, confirm the rated current and application environment of your model and use the wiring materials specified by Yaskawa or equivalent materials.
- **Securely tighten cable connector screws and lock mechanisms.**
Insufficient tightening may result in cable connectors falling off during operation.
- **Do not bundle power lines (e.g., the Main Circuit Cable) and low-current lines (e.g., the I/O Signal Cables or Encoder Cables) together or run them through the same duct. If you do not place power lines and low-current lines in separate ducts, separate them by at least 30 cm.**
If the cables are too close to each other, malfunctions may occur due to noise affecting the low-current lines.
- **Install a battery at either the host controller or on the Encoder Cable.**
If you install batteries both at the host controller and on the Encoder Cable at the same time, you will create a loop circuit between the batteries, resulting in a risk of damage or burning.
- **When connecting a battery, connect the polarity correctly.**
There is a risk of battery rupture or encoder failure.

Operation Precautions

**WARNING**

- **Before starting operation with a machine connected, change the settings of the switches and parameters to match the machine.**
Unexpected machine operation, failure, or personal injury may occur if operation is started before appropriate settings are made.
- **Do not radically change the settings of the parameters.**
There is a risk of unstable operation, machine damage, or injury.
- **Install limit switches or stoppers at the ends of the moving parts of the machine to prevent unexpected accidents.**
There is a risk of machine damage or injury.
- **For trial operation, securely mount the Servomotor and disconnect it from the machine.**
There is a risk of injury.
- **Forcing the motor to stop for overtravel is disabled when the Jog (Fn002), Origin Search (Fn003), or Easy FFT (Fn206) utility function is executed. Take necessary precautions.**
There is a risk of machine damage or injury.
- **When an alarm occurs, the motor will coast to a stop or stop with the dynamic brake according to a setting in the SERVOPACK. The coasting distance will change with the moment of inertia of the load. Check the coasting distance during trial operation and implement suitable safety measures on the machine.**
- **Do not enter the machine's range of motion during operation.**
There is a risk of injury.
- **Do not touch the moving parts of the Servomotor or machine during operation.**
There is a risk of injury.

**CAUTION**

- Design the system to ensure safety even when problems, such as broken signal lines, occur. For example, the P-OT and N-OT signals are set in the default settings to operate on the safe side if a signal line breaks. Do not change the polarity of this type of signal.
- When overtravel occurs, the power supply to the motor is turned OFF and the brake is released. If you use the Servomotor to drive a vertical load, set the Servomotor to enter a zero-clamped state after the Servomotor stops. Also, install safety devices (such as an external brake or counterweight) to prevent the moving parts of the machine from falling.
- Always turn OFF the servo before you turn OFF the power supply. If you turn OFF the main circuit power supply or control power supply during operation before you turn OFF the servo, the Servomotor will stop as follows:
 - If you turn OFF the main circuit power supply during operation without turning OFF the servo, the Servomotor will stop abruptly with the dynamic brake.
 - If you turn OFF the control power supply without turning OFF the servo, the stopping method that is used by the Servomotor depends on the model of the SERVOPACK. For details, refer to the manual for the SERVOPACK.
 - If you use a SERVOPACK with the Dynamic Brake Hardware Option, the Servomotor stopping methods will be different from the stopping methods used without the Option or with other Hardware Options. For details, refer to the following manual.
 - 📖 Σ -7-Series Σ -7S/ Σ -7W SERVOPACK with Dynamic Brake Hardware Option Specifications Product Manual (Manual No.: SIEP S800001 73)
- **Do not use the dynamic brake for any application other than an emergency stop.**

There is a risk of failure due to rapid deterioration of elements in the SERVOPACK and the risk of unexpected operation, machine damage, burning, or injury.

**NOTICE**

- **When you adjust the gain during system commissioning, use a measuring instrument to monitor the torque waveform and speed waveform and confirm that there is no vibration.**

If a high gain causes vibration, the Servomotor will be damaged quickly.
- **Do not frequently turn the power supply ON and OFF. After you have started actual operation, allow at least one hour between turning the power supply ON and OFF (as a guideline). Do not use the product in applications that require the power supply to be turned ON and OFF frequently.**

The elements in the SERVOPACK will deteriorate quickly.
- **An alarm or warning may occur if communications are performed with the host controller while the SigmaWin+ or Digital Operator is operating.**

If an alarm or warning occurs, it may interrupt the current process and stop the system.
- **After you complete trial operation of the machine and facilities, use the SigmaWin+ to back up the settings of the SERVOPACK parameters. You can use them to reset the parameters after SERVOPACK replacement.**

If you do not copy backed up parameter settings, normal operation may not be possible after a faulty SERVOPACK is replaced, possibly resulting in machine or equipment damage.

Maintenance and Inspection Precautions**DANGER**

Do not change any wiring while power is being supplied.

There is a risk of electric shock or injury.

**WARNING**

Wiring and inspections must be performed only by qualified engineers.

There is a risk of electric shock or product failure.

**CAUTION**

- Wait for at least six minutes after turning OFF the power supply (with a SERVOPACK for a 100- VAC power supply input, wait for at least nine minutes) and then make sure that the CHARGE indicator is not lit before starting wiring or inspection work. Do not touch the power supply terminals while the CHARGE lamp is lit after turning OFF the power supply because high voltage may still remain in the SERVOPACK.

There is a risk of electric shock.

- Before you replace a SERVOPACK, back up the settings of the SERVOPACK parameters. Copy the backed up parameter settings to the new SERVOPACK and confirm that they were copied correctly.

If you do not copy backed up parameter settings or if the copy operation is not completed normally, normal operation may not be possible, possibly resulting in machine or equipment damage.

**NOTICE**

Discharge all static electricity from your body before you operate any of the buttons or switches inside the front cover of the SERVOPACK.

There is a risk of equipment damage.

Troubleshooting Precautions**DANGER**

If the safety device (molded-case circuit breaker or fuse) installed in the power supply line operates, remove the cause before you supply power to the SERVOPACK again. If necessary, repair or replace the SERVOPACK, check the wiring, and remove the factor that caused the safety device to operate.

There is a risk of fire, electric shock, or injury.

**WARNING**

The product may suddenly start to operate when the power supply is recovered after a momentary power interruption. Design the machine to ensure human safety when operation restarts.

There is a risk of injury.

**CAUTION**

- When an alarm occurs, remove the cause of the alarm and ensure safety. Then reset the alarm or turn the power supply OFF and ON again to restart operation.

There is a risk of injury or machine damage.

- If the Servo ON signal is input to the SERVOPACK and an alarm is reset, the Servomotor may suddenly restart operation. Confirm that the servo is OFF and ensure safety before you reset an alarm.

There is a risk of injury or machine damage.

- Always insert a Magnetic Contactor in the line between the main circuit power supply and the main circuit power supply terminals on the SERVOPACK so that the power supply can be shut OFF at the main circuit power supply.

If a Magnetic Contactor is not connected when the SERVOPACK fails, a large current may flow, possibly resulting in fire.

- If an alarm occurs, shut OFF the main circuit power supply.

There is a risk of fire due to a Regenerative Resistor overheating as the result of regenerative transistor failure.

- Install a ground fault detector against overloads and short-circuiting or install a molded-case circuit breaker combined with a ground fault detector.

There is a risk of SERVOPACK failure or fire if a ground fault occurs.

- The holding brake on a Servomotor will not ensure safety if there is the possibility that an external force (including gravity) may move the current position and create a hazardous situation when power is interrupted or an error occurs. If an external force may cause movement, install an external braking mechanism that ensures safety.

Disposal Precautions

- When disposing of the product, treat it as ordinary industrial waste. However, local ordinances and national laws must be observed. Implement all labeling and warnings as a final product as required.

General Precautions

- Figures provided in this document are typical examples or conceptual representations. There may be differences between them and actual wiring, circuits, and products.
- The products shown in illustrations in this document are sometimes shown without covers or protective guards. Always replace all covers and protective guards before you use the product.
- If you need a new copy of this document because it has been lost or damaged, contact your nearest Yaskawa representative or one of the offices listed on the back of this document.
- This document is subject to change without notice for product improvements, specifications changes, and improvements to the manual itself.
- We will update the document number of the document and issue revisions when changes are made.
- Any and all quality guarantees provided by Yaskawa are null and void if the customer modifies the product in any way. Yaskawa disavows any responsibility for damages or losses that are caused by modified products.

1.6 Warranty**Details of Warranty**

- Warranty Period

The warranty period for a product that was purchased (hereinafter called the “delivered product”) is one year from the time of delivery to the location specified by the customer or 18 months from the time of shipment from the Yaskawa factory, whichever is sooner.

■ **Warranty Scope**

Yaskawa shall replace or repair a defective product free of charge if a defect attributable to Yaskawa occurs during the above warranty period.

This warranty does not cover defects caused by the delivered product reaching the end of its service life and replacement of parts that require replacement or that have a limited service life.

This warranty does not cover failures that result from any of the following causes.

- Improper handling, abuse, or use in unsuitable conditions or in environments not described in product catalogs or manuals, or in any separately agreed-upon specifications
- Causes not attributable to the delivered product itself
- Modifications or repairs not performed by Yaskawa
- Use of the delivered product in a manner in which it was not originally intended
- Causes that were not foreseeable with the scientific and technological understanding at the time of shipment from Yaskawa
- Events for which Yaskawa is not responsible, such as natural or human-made disasters

■ **Limitations of Liability**

- Yaskawa shall in no event be responsible for any damage or loss of opportunity to the customer that arises due to failure of the delivered product.
- Yaskawa shall not be responsible for any programs (including parameter settings) or the results of program execution of the programs provided by the user or by a third party for use with programmable Yaskawa products.
- The information described in product catalogs or manuals is provided for the purpose of the customer purchasing the appropriate product for the intended application. The use thereof does not guarantee that there are no infringements of intellectual property rights or other proprietary rights of Yaskawa or third parties, nor does it construe a license.
- Yaskawa shall not be responsible for any damage arising from infringements of intellectual property rights or other proprietary rights of third parties as a result of using the information described in catalogs or manuals.

■ **Suitability for Use**

- It is the customer’s responsibility to confirm conformity with any standards, codes, or regulations that apply if the Yaskawa product is used in combination with any other products.
- The customer must confirm that the Yaskawa product is suitable for the systems, machines, and equipment used by the customer.
- Consult with Yaskawa to determine whether use in the following applications is acceptable. If use in the application is acceptable, use the product with extra allowance in ratings and specifications, and provide safety measures to minimize hazards in the event of failure.
 - Outdoor use, use involving potential chemical contamination or electrical interference, or use in conditions or environments not described in product catalogs or manuals
 - Nuclear energy control systems, combustion systems, railroad systems, aviation systems, vehicle systems, medical equipment, amusement machines, and installations subject to separate industry or government regulations
 - Systems, machines, and equipment that may present a risk to life or property
 - Systems that require a high degree of reliability, such as systems that supply gas, water, or electricity, or systems that operate continuously 24 hours a day
 - Other systems that require a similar high degree of safety

- Never use the product for an application involving serious risk to life or property without first ensuring that the system is designed to secure the required level of safety with risk warnings and redundancy, and that the Yaskawa product is properly rated and installed.
 - The circuit examples and other application examples described in product catalogs and manuals are for reference. Check the functionality and safety of the actual devices and equipment to be used before using the product.
 - Read and understand all use prohibitions and precautions, and operate the Yaskawa product correctly to prevent accidental harm to third parties.
- Specifications Change
- The names, specifications, appearance, and accessories of products in product catalogs and manuals may be changed at any time based on improvements and other reasons. The next editions of the revised catalogs or manuals will be published with updated code numbers. Consult with your Yaskawa representative to confirm the actual specifications before purchasing a product.

Compliance with UL Standards, EU Directives, and Other Safety Standards

1.7 Compliance with UL Standards, EU Directives, and Other Safety Standards

Certification marks for the standards for which the product has been certified by certification bodies are shown on nameplate. Products that do not have the marks are not certified for the standards.

North American Safety Standards (UL)



Fig. 5: UL certified and CSA logos

Product	Model	North American Safety Standards (UL File No.)
SERVOPACKs	<ul style="list-style-type: none"> ■ SGD7S 	UL 61800-5-1 (E147823), CSA C22.2 No.274
Rotary Servomotors	<ul style="list-style-type: none"> ■ SGMMV ■ SGM7A ■ SGM7J ■ SGM7P ■ SGM7G 	UL 1004-1 UL 1004-6 (E165827)
Direct Drive Servomotors	<ul style="list-style-type: none"> ■ SGM7E*1 ■ SGM7F*2 ■ SGMCV 	UL 1004-1 UL 1004-6 (E165827)
Linear Servomotors	<ul style="list-style-type: none"> ■ SGLGW ■ SGLFW ■ SGLFW2*1 ■ SGLTW 	UL 1004 (E165827)

*1. Certification is pending.

*2. SGM7F-□□B, -□□C, and -□□D: Certified; SGM7F-□□A: Certification is pending.

European Directives



Fig. 6: CE, TÜV SÜD Functional Safety and TÜV SÜD Production monitored Type Tested logos

Product	Model	EU Directive	Harmonized Standards
SERVOPACKs	■ SGD7S	Machinery Directive 2006/42/EC	EN ISO13849-1: 2015
		EMC Directive 2014/30/EU	EN 55011 group 1, class A EN 61000-6-2 EN 61000-6-4 EN 61800-3 (Category C2, Second environment)
		Low Voltage Directive 2014/35/EU	EN 50178 EN 61800-5-1
Rotary Servomotors	■ SGMMV	EMC Directive 2004/104/EC	EN 55011 group 1, class A EN 61000-6-2 EN 61800-3
		Low Voltage Directive 2006/95/EC	EN 60034-1 EN 60034-5
	■ SGM7J ■ SGM7A ■ SGM7P ■ SGM7G	EMC Directive 2014/30/EU	EN 55011 group 1, class A EN 61000-6-2 EN 61000-6-4 EN 61800-3 (Category C2, Second environment)
		Low Voltage Directive 2014/35/EU	EN 60034-1 EN 60034-5
Direct Drive Servomotors	■ SGM7E*1 ■ SGM7F ■ SGMCV ■ SGMCS- □□B, □□C, □□D, □□E (Small-Capacity, Coreless Servomotors)	EMC Directive 2004/108/EC	EN 55011 group 1, class A EN 61000-6-2 EN 61000-6-4*2 EN 61800-3*2
		Low Voltage Directive 2006/95/EC	EN 60034-1 EN 60034-5
Linear Servomotors	■ SGLG ■ SGLF ■ SGLFW2 ■ SGLT	EMC Directive 2004/108/EC	EN 55011 group 1, class A EN 61000-6-2 EN 61000-6-4

Compliance with UL Standards, EU Directives, and Other Safety Standards

Product	Model	EU Directive	Harmonized Standards
		Low Voltage Directive 2006/95/EC	EN 60034-1

*1. Certification is pending.

*2. SGM7E: Certification is pending, SGMCS: No application has been made for certification.



- We declared the CE Marking based on the harmonized standards in the above table.
- These products are for industrial use. In home environments, these products may cause electromagnetic interference and additional noise reduction measures may be necessary.

Safety Standards



Fig. 7: TÜV Süd Functional Safety

Product	Model	Safety Standards	Standards
SERVOPACKs	■ SGD7S	Safety of Machinery	EN ISO13849-1: 2015 IEC 60204-1
		Functional Safety	IEC 61508 series IEC 62061 IEC 61800-5-2
		EMC	IEC 61326-3-1

Safety Parameters

Item	Standards	Performance Level
Safety Integrity Level	IEC 61508	SIL3
	IEC 62061	SILCL3
Probability of Dangerous Failure per Hour	IEC 61508 IEC 62061	PFH = 4.04×10^{-9} [1/h] (4.04% of SIL3)
Performance Level	EN ISO 13849-1	PLe (Category 3)
Mean Time to Dangerous Failure of Each Channel	EN ISO 13849-1	MTTFd: High
Average Diagnostic Coverage	EN ISO 13849-1	DCavg: Medium
Stop Category	IEC 60204-1	Stop category 0
Safety Function	IEC 61800-5-2	STO
Mission Time	IEC 61508	10 years
Hardware Fault Tolerance	IEC 61508	HFT = 1
Subsystem	IEC 61508	B

2 Basic Information on SERVOPACKs

2.1 Overview

This chapter provides information required to select SERVOPACKs, such as SERVOPACK models and combinations with Servomotors.

2.2 The Σ -7 Series

The Σ -7-series SERVOPACKs are designed for applications that require frequent high-speed and high-precision positioning. The SERVOPACK will make the most of machine performance in the shortest time possible, thus contributing to improving productivity.

2.3 Introduction to PROFINET

2.3.1 Overview

PROFINET (acronym for **PRO**cess **FIELD** **NET**work) is an industry technical standard for data communication over Industrial Ethernet, designed for collecting data from, and controlling, equipment in industrial systems, with a particular strength in delivering data under tight time constraints (on the order of 1 ms or less). The standard is maintained and supported by *Profibus & Profinet International*, an umbrella organization headquartered in Karlsruhe, Germany.

The PROFINET Communications Reference SERVOPACKs implement the PROFIdrive drive profile for communications.

Basic position and speed control are supported along with synchronized position and speed. You can select the type of control to match your system from basic positioning to high-speed, high-precision path control.

You can also use PROFINET communications to control the high-level servo control performance, advanced turning functions and many actuators of the Σ -7 Series.

For more information on PROFINET and PROFINET communications, see [↔ Chap. 13.1 'PROFINET Communication' ...page 458](#)

PROFINET Terminology

For information on PROFINET terms used in this manual, see [↔ Chap. 1.4 'Using This Manual' ...page 23](#)

2.3.2 Data Types

The following table lists the data types and ranges that are used in this manual.

Code	Data Type	Coding (decimal)	Range
B	Boolean	1	–
SINT	Signed 8-bit integer	2	-128 to 127
INT	Signed 16-bit integer	3	-32,768 to 32,767
DINT	Signed 32-bit integer	4	-2,147,483,648 to 2,147,483,627
USINT	Unsigned 8-bit integer	5	0 to 255
UINT	Unsigned 16-bit integer	6	0 to 65,535
UDINT	Unsigned 32-bit integer	7	0 to 4,294,967,295
FP	Floating Point	8	–
VS	Visible String	9	–

Interpreting the Nameplate

Code	Data Type	Coding (decimal)	Range
OS	Octet String	10	—
N2	Normalised value 16 bit	113	—
N4	Normalised value 32 bit	114	—

2.3.3 Data Ranges

The following table lists the data units and notations that are used in this manual.

Notation	Description
Pos. unit	The user-defined position reference unit that is set in <i>position user unit</i> (2301h). 1 [Pos. unit] = 2301h 00 / 2301h 01 [inc]
Vel. unit	The user-defined speed reference unit that is set in <i>velocity user unit</i> (2302h). 1 [Vel. unit] = 2302h 00 / 2302h 01 [inc/ms]
Acc. unit	The user-defined acceleration reference unit that is set in <i>acceleration user unit</i> (2303h). 1 [Acc. unit] = 2303h 00 / 2303h 01 x 10 ⁴ [inc/s ²]
inc	This is the encoder pulse unit. For a 24-bit encoder, the resolution is 16,777,216 [inc] per rotation.

2.4 Interpreting the Nameplate

The following basic information is provided on the nameplate.

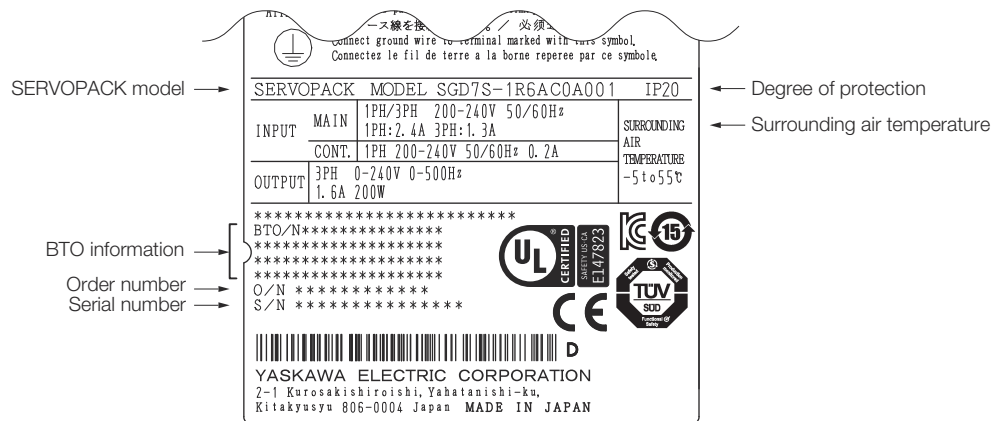


Fig. 8: Nameplate SGD7S-1R6A

2.5 Part Names

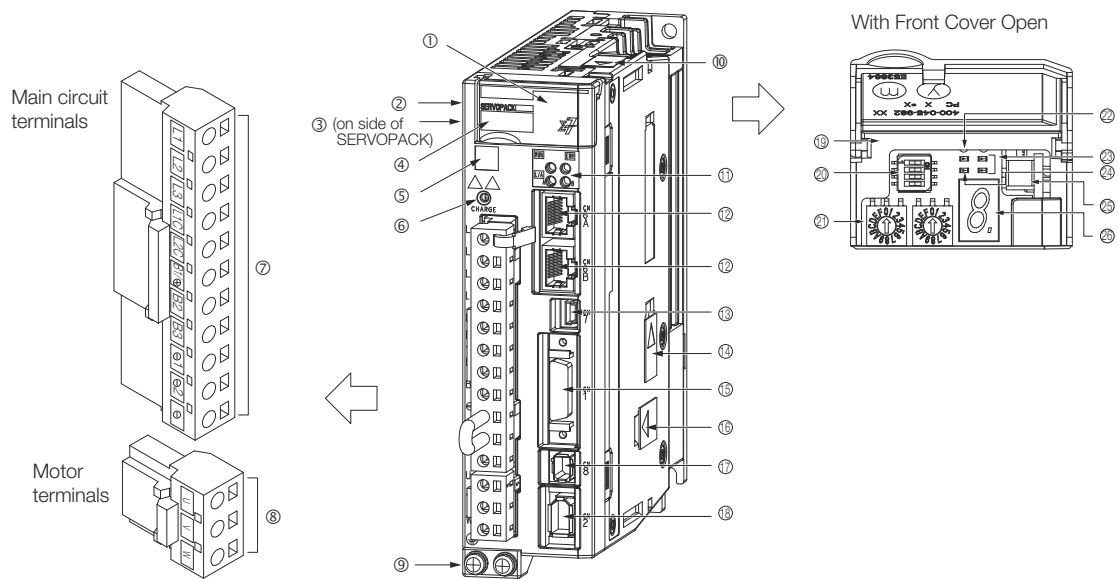


Fig. 9: Part Names SGD7S-1R6A

No.	Name	Description	Reference
1	Front Cover	–	–
2	Input Voltage	–	–
3	Nameplate	Indicates the SERVOPACK model and ratings.	→ Chap. 2.4 'Interpreting the Nameplate' ...page 44
4	Model	The model of the SERVOPACK.	→ Chap. 2.6.1 'Model Designations' ...page 47
5	QR Code	The QR code that is used by the Mechatro-Cloud service.	–
6	CHARGE	Lit while the main circuit power is being supplied. Note: Even if you turn OFF the main circuit power supply, this indicator will be lit as long as the internal capacitor remains charged. Do not touch the main circuit or motor terminals while this indicator is lit. Doing so may result in electric shock.	–
7	Main Circuit Terminals	The terminals depend on the main circuit power supply input specifications of the SERVOPACK.	→ Chap. 5.4.2 'Terminal Symbols and Terminal Names' ...page 91
8	Servomotor Terminals (U, V, and W)	The connection terminals for the Servomotor Main Circuit Cable (power line).	→ Chap. 5.5.1 'Terminal Symbols and Terminal Names' ...page 105
9	Ground Terminal (⊕)	The ground terminals to prevent electric shock. Always connect this terminal.	–
10	Serial Communications Connector (CN502)	Connects to the Digital Operator. However, a Communications Unit (JUSP-JC001-1) is required to connect a Digital Operator.	→ Chap. 5.9.1 'Serial Communications Connector (CN502)' ...page 125

Part Names

No.	Name	Description	Reference
11	Communications Status Indicators	Indicate the status of PROFINET communications.	–
12	PROFINET Communications Connectors (Input: CN6A, Output: CN6B)	Connect to PROFINET devices.	↪ Chap. 5.8.2 'PROFINET Connectors (RJ45)' ...page 124
13	Computer Connector (CN7)	A USB connector to connect a computer.	↪ Chap. 5.9.2 'Computer Connector (CN7)' ...page 126
14	Safety Option Module Connector	Connects to a Safety Option Module.	–
15	I/O Signal Connector (CN1)	Connects to sequence I/O signals.	↪ Chap. 5.6.1 'I/O Signal Connector (CN1) Names and Functions' ...page 114
16	Feedback Option Module Connector	Connects to a Feedback Option Module.	–
17	Safety Connector (CN8)	Connects to a safety function device.	↪ Chap. 5.7.2 'Pin Arrangement of Safety Function Signals (CN8)' ...page 121
18	Encoder Connector (CN2)	<ul style="list-style-type: none"> ■ Rotary Servomotor: Connects to the encoder in the Servomotor. ■ Linear Servomotor: Connects to a Serial Converter Unit or linear encoder. 	↪ Chap. 5.5.2 'Pin Arrangement of Encoder Connector (CN2)' ...page 105
19	Serial Number	–	–
20	DIP Switch (S3)	Not used.	–
21	Switches S1 and S2	Not used.	–
22	PWR	Lights when the control power is being supplied.	–
23	CN	Not used.	–
24	L1 and L2	–	–
25	Analog Monitor Connector (CN5)	You can use a special cable (peripheral device) to monitor the motor speed, torque reference, or other values.	↪ Chap. 5.9.3 'Analog Monitor Connector (CN5)' ...page 126
26	Panel Display	Displays the servo status with a seven-segment display.	–

2.6 Model Designations

2.6.1 Interpreting SERVOPACK Model Numbers

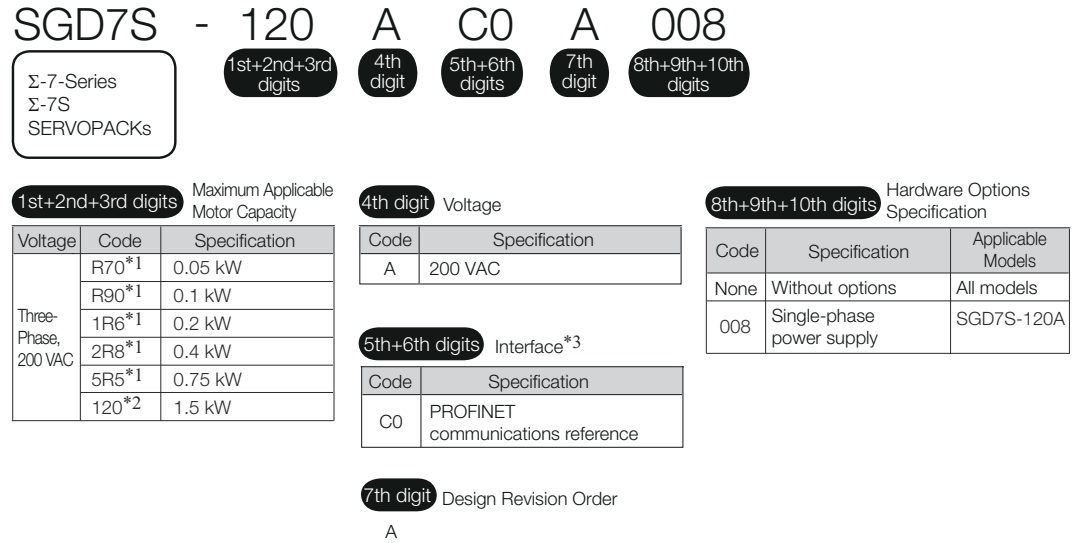


Fig. 10: SGD7S SERVOPACK Model Numbers

- *1. You can use these models with either a single-phase or three-phase input.
- *2. A model with a single-phase, 200-VAC power supply input is available as a hardware option (model: SGD7S-120AC0A008).
- *3. The same SERVOPACKs are used for both Rotary Servomotors and Linear Servomotors.

2.6.2 Interpreting Servomotor Model Numbers

This section outlines the model numbers of Σ-7-series Servomotors. Refer to the relevant manual in the following list for details.

- 📖 Σ-7-Series Rotary Servomotor Product Manual (Manual No.: SIEP S800001 36)
- 📖 Σ-7-Series Linear Servomotor Product Manual (Manual No.: SIEP S800001 37)
- 📖 Σ-7-Series Direct Drive Servomotor Product Manual (Manual No.: SIEP S800001 38)

Rotary Servomotors

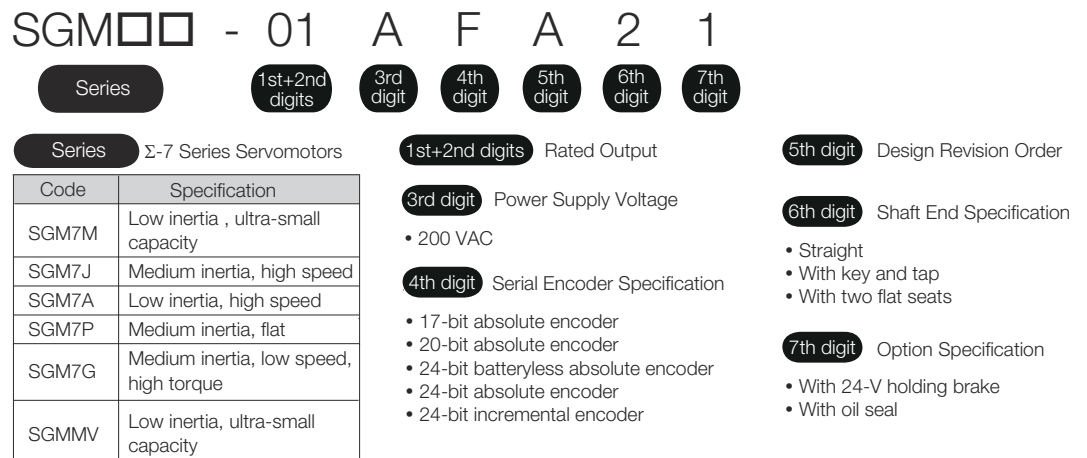


Fig. 11: SGM Rotary Servomotor Model Numbers

Direct Drive Servomotors

SGM□□ - 02 B 3 C 1 1

Series 1st+2nd digits 3rd digit 4th digit 5th digit 6th digit 7th digit

Series Σ-7 Series Servomotors 1st+2nd digits Rated Torque 5th digit Design Revision Order

Code	Specification
SGM7E	Small capacity, coreless, inner rotor
SGM7F	Small capacity, with core, inner rotor
	Medium capacity, with core, inner rotor
SGM7C	Small capacity, with core, inner rotor
SGM7S	Small capacity, coreless, inner rotor
	Medium capacity, with core, inner rotor

3rd digit Servomotor Outer Diameter

4th digit Serial Encoder Specification

6th digit Flange Specification

- Cable drawn to load side
- Cable drawn to non-load side

7th digit Option Specification

- High mechanical precision

Fig. 12: SGM Direct Drive Servomotor Model Numbers

Linear Servomotors

SGL □ □ - 30 A 050 C P □

Series 1st digit 2nd digit 3rd digit on

Series Σ-7 Series Servomotors 2nd digit Moving Coil/Magnetic Way

1st digit Servomotor Type

Code	Specification
G	Coreless models
F	Models with F-type iron core
T	Models with T-type iron core

Code	Specification
W	Moving Coil
W2	
M	Magnetic Way
M2	

3rd digit on

The specifications for the 3rd digit on depend on the Servomotor type.

Fig. 13: SGL Linear Servomotor Model Numbers

2.7 Combinations of SERVOPACKs and Servomotors

2.7.1 Combinations of Rotary Servomotors and SERVOPACKs

Rotary Servomotor Model		Capacity	SERVOPACK Model
			SGD7S-
SGMMV (Low Inertia, Ultrasmall Capacity), 3,000 min ⁻¹	SGMMV-A1A	11 W	R90A or R90F
	SGMMV-A2A	22 W	
	SGMMV-A3A	33 W	1R6A or 2R1F
SGM7J (Medium Inertia, Small Capacity), 3,000 min ⁻¹	SGM7J-A5A	50 W	R70A or R70F
	SGM7J-01A	100 W	R90A or R90F
	SGM7J-C2A	150 W	1R6A or 2R1F
	SGM7J-02A	200 W	
	SGM7J-04A	400 W	2R8A or 2R8F
	SGM7J-06A	600 W	5R5A
	SGM7J-08A	750 W	
SGM7A (Low Inertia, Small Capacity), 3,000 min ⁻¹	SGM7A-A5A	50 W	R70A or R70F
	SGM7A-01A	100 W	R90A or R90F
	SGM7A-C2A	150 W	1R6A or 2R1F
	SGM7A-02A	200 W	
	SGM7A-04A	400 W	2R8A or 2R8F
	SGM7A-06A	600 W	5R5A
	SGM7A-08A	750 W	
	SGM7A-10A	1.0 kW	120A
	SGM7A-15A	1.5 kW	
	SGM7A-20A	2.0 kW	180A
	SGM7A-25A	2.5 kW	200A
	SGM7A-30A	3.0 kW	
	SGM7A-40A	4.0 kW	330A
	SGM7A-50A	5.0 kW	
SGM7A-70A	7.0 kW	550A	
SGM7P (Medium Inertia, Flat), 3,000 min ⁻¹	SGM7P-01A	100 W	R90A or R90F
	SGM7P-02A	200 W	2R8A or 2R1F
	SGM7P-04A	400 W	2R8A or 2R8F
	SGM7P-08A	750 W	5R5A
	SGM7P-15A	1.5 kW	120A
SGM7G (Medium Inertia, Medium Capacity), 1,500 min ⁻¹	SGM7G-03A	300 W	3R8A
	SGM7G-05A	450 W	
	SGM7G-09A	850 W	7R6A
	SGM7G-13A	1.3 kW	120A

Rotary Servomotor Model		Capacity	SERVOPACK Model
			SGD7S-
	SGM7G-20A	1.8 kW	180A
	SGM7G-30A	2.9 kW* ¹	330A
	SGM7G-44A	4.4 kW	
	SGM7G-55A	5.5 kW	470A
	SGM7G-75A	7.5 kW	550A
	SGM7G-1AA	11 kW	590A
	SGM7G-1EA	15 kW	780A
SGMMV* ² (Low Inertia, Ultrasmall Capacity), 3,000 min ⁻¹	SGMMV-A1A	10 W	R90A or R90F
	SGMMV-A2A	20 W	
	SGMMV-A3A	30 W	1R6A or 2R1F

*1 2.4 kW when using the Servomotor with a SGD7S-200A SERVOPACK.

*2. The SGMMV Servomotor is an older model. When purchasing a new Servomotor, we recommend selecting a SGM7M Servomotor.


2.7.2 Combinations of Direct Drive Servomotors and SERVOPACKs

Direct Drive Servomotor Model		Rated Torque [Nm]	Instantaneous Maximum Torque [Nm]	SERVO-PACK Model
				SGD7S-
SGM7E (Small Capacity, Coreless, Inner Rotor)	SGM7E-02B	2	6	2R8A or 2R1F
	SGM7E-05B	5	15	
	SGM7E-07B	7	21	
	SGM7E-04C	4	12	2R8A or 2R8F
	SGM7E-10C	10	30	
	SGM7E-14C	14	42	
	SGM7E-08D	8	24	
	SGM7E-17D	17	51	
	SGM7E-25D	25	75	
	SGM7E-16E	16	48	5R5A
	SGM7E-35E	35	105	
SGM7F (Small Capacity, With Core, Inner Rotor)	SGM7F-02A	2	6	2R8A or 2R1F
	SGM7F-05A	5	15	
	SGM7F-07A	7	21	2R8A or 2R8F
	SGM7F-04B	4	12	
	SGM7F-10B	10	30	
	SGM7F-14B	14	42	5R5A

Direct Drive Servomotor Model		Rated Torque [Nm]	Instantaneous Maximum Torque [Nm]	SERVO-PACK Model
				SGD7S-
	SGM7F-08C	8	24	2R8A or 2R8F
	SGM7F-17C	17	51	5R5A
	SGM7F-25C	25	75	7R6A
	SGM7F-16D	16	48	5R5A
	SGM7F-35D	35	105	7R6A* or 120A
SGM7F (Medium Capacity, With Core, Inner Rotor)	SGM7F-45M	45	135	7R6A
	SGM7F-80M	80	240	120A
	SGM7F-80N	80	240	
	SGM7F-1AM	110	330	180A
	SGM7F-1EN	150	450	200A
	SGM7F-2ZN	200	600	
SGM7F (Small Capacity, With Core, Inner Rotor)	SGM7F-04B	4	12	2R8A or 2R8F
	SGM7F-10B	10	30	
	SGM7F-14B	14	42	5R5A
	SGM7F-08C	8	24	2R8A or 2R8F
	SGM7F-17C	17	51	5R5A
	SGM7F-25C	25	75	7R6A
	SGM7F-16D	16	48	5R5A
	SGM7F-35D	35	105	7R6A* or 120A
SGM7F (Small Capacity, Coreless, Inner Rotor)	SGM7F-02B	2	6	2R8A or 2R1F
	SGM7F-05B	5	15	
	SGM7F-07B	7	21	
	SGM7F-04C	4	12	2R8A or 2R8F
	SGM7F-10C	10	30	
	SGM7F-14C	14	42	
	SGM7F-08D	8	24	
	SGM7F-17D	17	51	
	SGM7F-25D	25	75	
	SGM7F-16E	16	48	5R5A
	SGM7F-35E	35	105	
	SGM7F-80N	80	240	
SGM7F (Medium Capacity, With Core, Inner Rotor)	SGM7F-45M	45	135	7R6A
	SGM7F-80M	80	240	120A
	SGM7F-80N	80	240	

Direct Drive Servomotor Model		Rated Torque [Nm]	Instantaneous Maximum Torque [Nm]	SERVO-PACK Model
				SGD7S-
	SGMCS-1AM	110	330	180A
	SGMCS-1EN	150	450	200A
	SGMCS-2ZN	200	600	

* Use derated values for this combination. Refer to the following catalog for information on derating values.

 AC Servo Drives Σ -7 Series (Manual No.: KAEP S800001 23)

2.7.3 Combinations of Linear Servomotors and SERVOPACKs

Linear Servomotor Model		Rated Force [N]	Instantaneous Maximum Force [N]	SERVO-PACK Model
				SGD7S-
SGLG (Coreless Models), Used with Standard- Force Magnetic Way	SGLGW-30A050C	12.5	40	R70A, R70F
	SGLGW-30A080C	25	80	R90A, R90F
	SGLGW-40A140C	47	140	
	SGLGW-40A253C	93	280	1R6A, 2R1F
	SGLGW-40A365C	140	420	2R8A, 2R8F
	SGLGW-60A140C	70	220	1R6A, 2R1F
	SGLGW-60A253C	140	440	2R8A, 2R1F
	SGLGW-60A365C	210	660	5R5A
	SGLGW-90A200C	325	1300	120A
	SGLGW-90A370C	550	2200	180A
	SGLGW-90A535C	750	3000	200A
SGLG (Coreless Models), Used with High- Force Magnetic Way	SGLGW-40A140C	57	230	1R6A, 2R1F
	SGLGW-40A253C	114	460	2R8A, 2R8F
	SGLGW-40A365C	171	690	3R8A
	SGLGW-60A140C	85	360	1R6A, 2R1F
	SGLGW-60A253C	170	720	3R8A
	SGLGW-60A365C	255	1080	7R6A
SGLF (Models with F-type Iron Cores)	SGLFW-20A090A	25	86	1R6A, 2R1F
	SGLFW-20A120A	40	125	

Linear Servomotor Model		Rated Force [N]	Instantaneous Maximum Force [N]	SERVO-PACK Model
				SGD7S-
	SGLFW-35A120A	80	220	
	SGLFW-35A230A	160	440	3R8A
	SGLFW-50A200B	280	600	5R5A
	SGLFW-50A380B	560	1200	120A
	SGLFW-1ZA200B			
	SGLFW-1ZA380B	1120	2400	200A
	SGLFW2-30A070A	45	135	1R6A, 2R1F
	SGLFW2-30A120A	90	270	
	SGLFW2-30A230A*	180	540	3R8A
		170	500	2R8A
	SGLFW2-45A200A	280	840	5R5A
	SGLFW2-45A380A*	560	1680	180A
			1500	120A
	SGLFW2-90A200A	560	1680	
	SGLFW2-90A380A	1120	3360	200A
	SGLFW2-1DA380A	1680	5040	
SGLT (Models with T-type Iron Cores)	SGLTW-20A170A	130	380	3R8A
	SGLTW-20A320A	250	760	7R6A
	SGLTW-20A460A	380	1140	120A
	SGLTW-35A170A	220	660	5R5A
	SGLTW-35A170H	300	600	
	SGLTW-35A320A	440	1320	120A
	SGLTW-35A320H	600	1200	
	SGLTW-35A460A	670	2000	180A
	SGLTW-40A400B	670	2600	
	SGLTW-40A600B	1000	4000	330A
	SGLTW-50A170H	450	900	5R5A
	SGLTW-50A320H	900	1800	120A
	SGLTW-80A400B	1300	5000	330A
	SGLTW-80A600B	2000	7500	550A

* The force depends on the SERVOPACK that is used with the Servomotor.

2.8 Functions

This section lists the functions provided by SERVOPACKs. Refer to the reference pages for details on the functions.

Functions Related to the Machine

Function	Reference
Power Supply Type Settings for the Main Circuit and Control Circuit	➔ Chap. 6.3.1 'Power Supply Type Settings for the Main Circuit and Control Circuit' ...page 138
Automatic Detection of Connected Motor	➔ Chap. 6.4 'Automatic Detection of Connected Motor' ...page 140
Motor Direction Setting	➔ Chap. 6.5 'Motor Direction Setting' ...page 141
Linear Encoder Pitch Setting	➔ Chap. 6.6 'Setting the Linear Encoder Pitch' ...page 142
Writing Linear Servomotor Parameters	➔ Chap. 6.7 'Writing Linear Servomotor Parameters' ...page 143
Selecting the Phase Sequence for a Linear Servomotor	➔ Chap. 6.8 'Selecting the Phase Sequence for a Linear Servomotor' ...page 150
Polarity Sensor Setting	➔ Chap. 6.9 'Polarity Sensor Setting' ...page 152
Polarity Detection	➔ Chap. 6.10.1 'Polarity Detection' ...page 152
Overtravel Function and Settings	➔ Chap. 6.11.1 'Overtravel and Related Settings' ...page 155
Holding Brake	➔ Chap. 6.12.1 'Holding Brake' ...page 161
Motor Stopping Methods for Servo OFF and Alarms	➔ Chap. 6.13.1 'Motor Stopping Methods for Servo OFF and Alarms' ...page 166
Resetting the Absolute Encoder	➔ Chap. 6.16.1 'Resetting the Absolute Encoder' ...page 179
Setting the Origin of the Absolute Encoder	➔ Chap. 6.17.1 'Setting the Origin of the Absolute Encoder' ...page 183
Setting the Regenerative Resistor Capacity	➔ Chap. 6.18 'Setting the Regenerative Resistor Capacity' ...page 187
Operation for Momentary Power Interruptions	➔ Chap. 7.3 'Operation for Momentary Power Interruptions' ...page 200
SEMI F47 Function	➔ Chap. 7.4 'SEMI F47 Function' ...page 201
Setting the Motor Maximum Speed	➔ Chap. 7.5 'Setting the Motor Maximum Speed' ...page 203
Software Limits	➔ Chap. 7.7 'Software Limits' ...page 212
Multiturn Limit Setting	➔ Chap. 7.9.8 'Multiturn Limit Setting' ...page 224

Function	Reference
Adjustment of Motor Current Detection Signal Offset	↪ Chap. 7.13.1 'Adjusting the Motor Current Detection Signal Offset' ...page 241
Forcing the Motor to Stop	↪ Chap. 7.14.1 'Forcing the Motor to Stop' ...page 245
Overheat Protection	↪ Chap. 7.15.1 'Overheat Protection' ...page 248
Speed Ripple Compensation	↪ Chap. 9.12.1 'Speed Ripple Compensation' ...page 361
Current Control Mode Selection	↪ Chap. 9.13.5 'Current Control Mode Selection' ...page 377
Current Gain Level Setting	↪ Chap. 9.13.6 'Current Gain Level Setting' ...page 378
Speed Detection Method Selection	↪ Chap. 9.13.7 'Speed Detection Method Selection' ...page 378
Fully-Closed Loop Control	↪ Chap. 11.1 'Fully-Closed Loop Control' ...page 429
Safety Functions	↪ Chap. 12.1 'Safety Functions' ...page 440
Touch Probe	↪ Chap. 14.9 'Touch Probe Function' ...page 489

Functions Related to the Host Controller

Function	Reference
Setting Unit Systems	↪ Chap. 6.15.2 'Setting the Position Reference Unit' ...page 172
I/O Signal Allocations	↪ Chap. 7.2.1 'I/O Signal Allocations' ...page 189
ALM (Servo Alarm) Signal	↪ Chap. 7.2.4 'ALM (Servo Alarm) Signal' ...page 192
/WARN (Warning Output) Signal	↪ Chap. 7.2.5 '/WARN (Warning) Signal' ...page 192
/TGON (Rotation Detection) Signal	↪ Chap. 7.2.6 '/TGON (Rotation Detection) Signal' ...page 193
/S-RDY (Servo Ready) Signal	↪ Chap. 7.2.7 '/S-RDY (Servo Ready) Signal' ...page 194
/V-CMP (Speed Coincidence Detection) Signal	↪ Chap. 7.2.8 '/V-CMP (Speed Coincidence Detection) Signal' ...page 195
/COIN (Positioning Completion) Signal	↪ Chap. 7.2.9 '/COIN (Positioning Completion) Signal' ...page 196
/NEAR (Near) Signal	↪ Chap. 7.2.10 '/NEAR (Near) Signal' ...page 197
Speed Limit during Torque Control	↪ Chap. 7.2.11 'Speed Limit during Torque Control' ...page 199
/VLT (Speed Limit Detection) Signal	↪ '/VLT (Speed Limit Detection) Signal' ...page 199

Functions

Function	Reference
Encoder Divided Pulse Output	➔ Chap. 7.6.1 'Encoder Divided Pulse Output' ...page 204
Selecting Torque Limits	➔ Chap. 7.8.1 'Selecting Torque Limits' ...page 212
Vibration Detection Level Initialization	➔ Chap. 7.12.1 'Initializing the Vibration Detection Level' ...page 236
Alarm Reset	➔ Chap. 16.4.4 'Resetting Alarms' ...page 594
Replacing the Battery	➔ Chap. 16.2.4 'Replacing the Battery' ...page 547
Setting the Position Deviation Overflow Alarm Level	➔ Chap. 9.4.4 'Setting the Position Deviation Overflow Alarm Level' ...page 287

Functions to Achieve Optimum Motions

Function	Reference
Tuning-less Function	➔ Chap. 9.5.1 'Tuning-less Function' ...page 290
Autotuning without a Host Reference	➔ Chap. 9.7.1 'Autotuning without Host Reference' ...page 306
Autotuning with a Host Reference	➔ Chap. 9.8.1 'Autotuning with a Host Reference' ...page 322
Custom Tuning	➔ Chap. 9.9.1 'Custom Tuning' ...page 332
Anti-Resonance Control Adjustment	➔ Chap. 9.10.1 'Anti-Resonance Control Adjustment' ...page 347
Vibration Suppression	➔ Chap. 9.11.1 'Vibration Suppression' ...page 355
Gain Selection	➔ Chap. 9.13.2 'Gain Switching' ...page 370
Friction Compensation	➔ Chap. 9.13.3 'Friction Compensation' ...page 374
Backlash Compensation	➔ Chap. 9.13.9 'Backlash Compensation' ...page 379
Model Following Control	➔ Chap. 9.14.2 'Tuning the Servo Gains' ...page 385
Compatible Adjustment Functions	➔ Chap. 9.14.3 'Compatible Adjustment Functions' ...page 397
Mechanical Analysis	➔ Chap. 9.15.1 'Mechanical Analysis' ...page 402
Easy FFT	➔ Chap. 9.15.2 'Easy FFT' ...page 403

Functions for Trial Operation during Setup

Function	Reference
Software Reset	➔ Chap. 7.11.1 'Software Reset' ...page 233
Trial Operation for the Servomotor without a Load	➔ Chap. 8.4.1 'Trial Operation for the Servomotor without a Load' ...page 255
Program Jogging	➔ Chap. 8.7.2 'Program Jogging' ...page 264
Origin Search	➔ Chap. 8.7.3 'Origin Search' ...page 272
Test without a Motor	➔ Chap. 8.7.4 'Test without a Motor' ...page 275
Monitoring Machine Operation Status and Signal Waveforms	➔ Chap. 10.4.1 'Monitoring Machine Operation Status and Signal Waveforms' ...page 415

Functions for Inspection and Maintenance

Function	Reference
Write Prohibition Setting for Parameters	➔ Chap. 6.2.5 'Write Prohibition Setting for SERVOPACK Parameters' ...page 131
Initializing Parameter Settings	➔ Chap. 6.2.6 'Initializing SERVOPACK Parameter Settings' ...page 136
Automatic Detection of Connected Motor	➔ Chap. 6.4 'Automatic Detection of Connected Motor' ...page 140
Monitoring Product Information	➔ Chap. 10.2.1 'Monitoring Product Information' ...page 410
Monitoring Product Life	➔ Chap. 10.2.1 'Items That Can Be Monitored' ...page 410
Alarm History Display	➔ Chap. 16.4.5 'Displaying the Alarm History' ...page 594

3 Selecting a SERVOPACK

3.1 Overview

This chapter provides information required to select SERVOPACKs, such as specifications, block diagrams, dimensional drawings, and connection examples.

3.2 Ratings and Specifications

3.2.1 Ratings

This section gives the ratings and specifications of SERVOPACKs.

Three-Phase, 200 VAC

Model SGD7S-		R70A	R90A	1R6A	2R8A	5R5A
Maximum Applicable Motor Capacity [kW]		0.05	0.1	0.2	0.4	0.75
Continuous Output Current [Arms]		0.66	0.91	1.6	2.8	5.5
Instantaneous Maximum Output Current [Arms]		2.1	3.2	5.9	9.3	16.9
Main Circuit	Power Supply	200 VAC to 240 VAC, -15% to +10%, 50 Hz/60 Hz				
	Input Current [Arms]*	0.4	0.8	1.3	2.5	4.1
Control	Power Supply	200 VAC to 240 VAC, -15% to +10%, 50 Hz/60 Hz				
	Input Current [Arms]*	0.2	0.2	0.2	0.2	0.2
Power Supply Capacity [kVA]*		0.2	0.3	0.5	1.0	1.6
Power Loss*	Main Circuit Power Loss [W]	5.0	7.0	11.9	22.5	38.9
	Control Circuit Power Loss [W]	12	12	12	12	14
	Built-in Regenerative Resistor Power Loss [W]	–	–	–	–	8
	Total Power Loss [W]	17.0	19.0	23.9	34.5	60.9
Regenerative Resistor	Built-In Regenerative Resistor	Resistance [Ω]	–	–	–	40
		Capacity [W]	–	–	–	40
	Minimum Allowable External Resistance [Ω]	40	40	40	40	40
Overvoltage Category		III				

* This is the net value at the rated load.

Single-Phase, 200 VAC

Model SGD7S-		120A	
Maximum Applicable Motor Capacity [kW]		1.5	
Continuous Output Current [Arms]		11.6	
Instantaneous Maximum Output Current [Arms]		28	
Main Circuit	Power Supply	200 VAC to 240 VAC, -15% to +10%, 50 Hz/60 Hz	
	Input Current [Arms]*	16	
Control	Power Supply	200 VAC to 240 VAC, -15% to +10%, 50 Hz/60 Hz	
	Input Current [Arms]*	0.25	
Power Supply Capacity [kVA]*		4.0	
Power Loss*	Main Circuit Power Loss [W]	71.8	
	Control Circuit Power Loss [W]	16	
	Built-in Regenerative Resistor Power Loss [W]	12	
	Total Power Loss [W]	103.8	
Regenerative Resistor	Built-In Regenerative Resistor	Resistance [Ω]	12
		Capacity [W]	60
	Minimum Allowable External Resistance [Ω]	12	
Overvoltage Category		III	

* This is the net value at the rated load.

3.2.2 SERVOPACK Overload Protection Characteristics

The overload detection level is set for hot start conditions with a SERVOPACK surrounding air temperature of 55°C.

An overload alarm (A.710 or A.720) will occur if overload operation that exceeds the overload protection characteristics shown in the following diagram (i.e., operation on the right side of the applicable line) is performed.

The actual overload detection level will be the detection level of the connected SERVOPACK or Servomotor that has the lower overload protection characteristics.

In most cases, that will be the overload protection characteristics of the Servomotor.

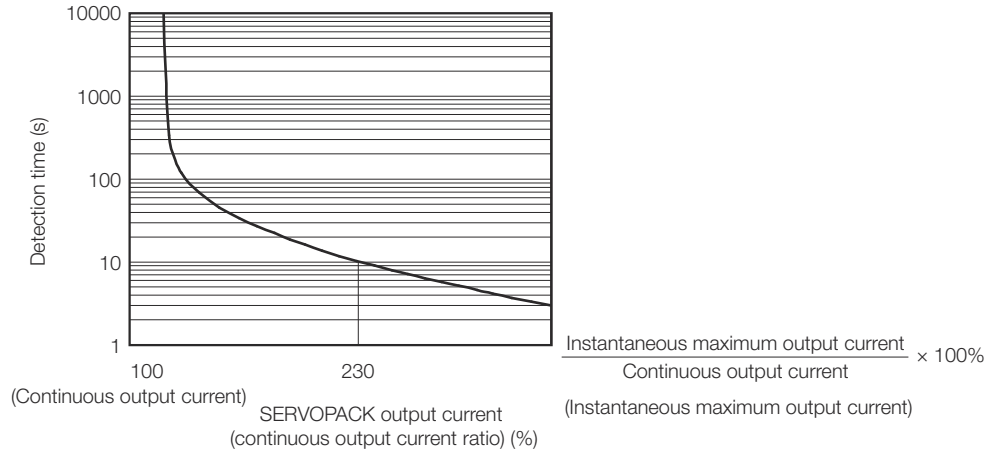


Fig. 14: SERVOPACK Overload Protection Characteristics - SGD7S-R70A, -R90A, -1R6A, -2R8A, -R70F, -R90F, -2R1F, and -2R8F



The above overload protection characteristics do not mean that you can perform continuous duty operation with an output of 100% or higher. For a Yaskawa-specified combination of SERVOPACK and Servomotor, maintain the effective torque within the continuous duty zone of the torque-motor speed characteristic of the Servomotor.

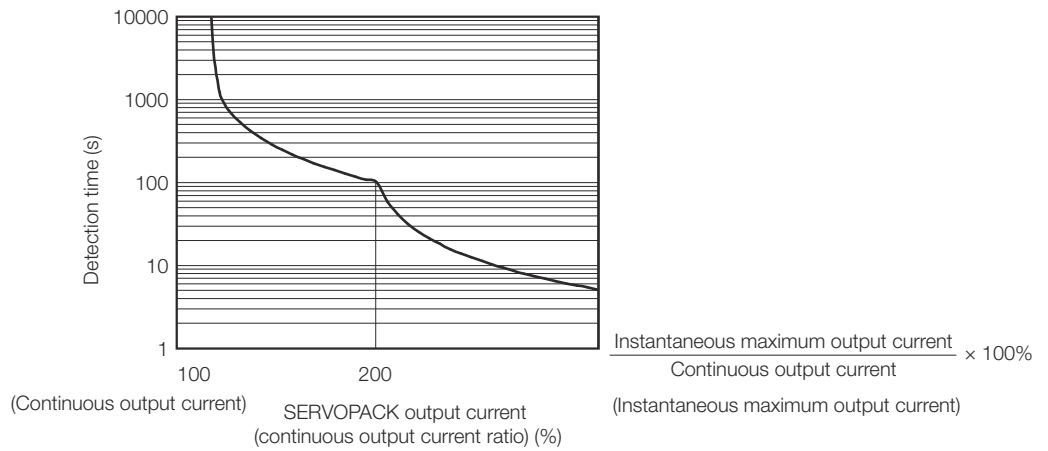


Fig. 15: SERVOPACK Overload Protection Characteristics - SGD7S-3R8A, -5R5A, -7R6A, -120A, -180A, -200A, -330A, -470A, -550A, -590A, and -780A



The above overload protection characteristics do not mean that you can perform continuous duty operation with an output of 100% or higher. For a Yaskawa-specified combination of SERVOPACK and Servomotor, maintain the effective torque within the continuous duty zone of the torque-motor speed characteristic of the Servomotor.

3.2.3 Specifications

Item	Specification
Control Method	IGBT-based PWM control, sine wave current drive

Item		Specification
Feedback	With Rotary Servomotor	Serial encoder: 20 bits or 24 bits (incremental encoder/absolute encoder) 22 bits (absolute encoder)
	With Linear Servomotor	<ul style="list-style-type: none"> ■ Absolute linear encoder (The signal resolution depends on the absolute linear encoder.) ■ Incremental linear encoder (The signal resolution depends on the incremental linear encoder or Serial Converter Unit.)
Environmental Conditions	Surrounding Air Temperature*1	-5°C to 55°C (With derating, usage is possible between 55°C and 60°C.) Refer to the following section for derating specifications. ↪ Chap. 4.7 'Derating Specifications' ...page 80
	Storage Temperature	-20°C to 85°C
	Surrounding Air Humidity	95% relative humidity max. (with no freezing or condensation)
	Storage Humidity	95% relative humidity max. (with no freezing or condensation)
	Vibration Resistance	4.9 m/s ²
	Shock Resistance	19.6 m/s ²
	Degree of Protection	IP20: R70A, R90A, 1R6A, 2R8A, 3R8A, 5R5A, 7R6A, 120A, R70F, R90F, 2R1F, 2R8F IP10: 120AA0A008, 180A, 200A, 330A, 470A, 550A, 590A, 780A
	Pollution Degree	2 <ul style="list-style-type: none"> ■ Must be no corrosive or flammable gases. ■ Must be no exposure to water, oil, or chemicals. ■ Must be no dust, salts, or iron dust.
	Altitude*1	1,000 m or less. (With derating, usage is possible between 1,000 m and 2,000 m.) Refer to the following section for derating specifications. ↪ Chap. 4.7 'Derating Specifications' ...page 80
Others	Do not use the SERVOPACK in the following locations: Locations subject to static electricity noise, strong electromagnetic/magnetic fields, or radioactivity	
Applicable Standards		Refer to the following section for details. ↪ Chap. 1.7 'Compliance with UL Standards, EU Directives, and Other Safety Standards' ...page 40
Mounting		Base-mounted: All Models Rack-mounted: R70A, R90A, 1R6A, 2R8A, 3R8A, 5R5A, 7R6A, 120A, 180A, 200A, 330A, R70F, R90F, 2R1F, 2R8F Duct-ventilated: 470A, 550A, 590A, 780A
Performance	Speed Control Range	1:5000 (At the rated torque, the lower limit of the speed control range must not cause the Servomotor to stop.)
	Coefficient of Speed Fluctuation*2	±0.01% of rated speed max. (for a load fluctuation of 0% to 100%)
		0% of rated speed max. (for a voltage fluctuation of ±10%)

Item		Specification
		±0.1% of rated speed max. (for a temperature fluctuation of 25°C ±25°C)
	Torque Control Precision (Repeatability)	±1%
	Soft Start Time Setting	0 s to 10 s (Can be set separately for acceleration and deceleration.)
I/O Signals	Encoder Divided Pulse Output	Phase A, phase B, phase C: Line-driver output Number of divided output pulses: Any setting is allowed.
	Overheat Protection Input	Number of input points: 1 Input voltage range: 0 V to +5 V
	Sequence Input Signals	Input Signals That Can Be Allocated Allowable voltage range: 24 VDC ±20% Number of input points: 7 (Input method: Sink inputs or source inputs) Input Signals <ul style="list-style-type: none"> ■ P-OT (Forward Drive Prohibit) and N-OT (Reverse Drive Prohibit) signals ■ /EXT1 (Probe 1 Latch Input) signal ■ /EXT2 (Probe 2 Latch Input) signal ■ /DEC (Home Switch Input) signal ■ /P-CL (Forward External Torque Limit) and /N-CL (Reverse External Torque Limit) signals ■ FSTP (Forced Stop Input) signal A signal can be allocated and the positive and negative logic can be changed.
	Sequence Output Signals	Fixed Output Allowable voltage range: 5 VDC to 30 VDC Number of output points: 1 Output signal: ALM (Servo Alarm) signal
		Output Signals That Can Be Allocated Allowable voltage range: 5 VDC to 30 VDC Number of output points: 5 (A photocoupler output (isolated) is used.) Output Signals <ul style="list-style-type: none"> ■ /COIN (Positioning Completion) signal ■ /V-CMP (Speed Coincidence Detection) signal ■ /TGON (Rotation Detection) signal ■ /S-RDY (Servo Ready) signal ■ /CLT (Torque Limit Detection) signal ■ /VLT (Speed Limit Detection) signal ■ /BK (Brake) signal ■ /WARN (Warning) signal ■ /NEAR (Near) signal A signal can be allocated and the positive and negative logic can be changed.
Communications	RS-422A Communications (CN502)	Interfaces A JUSP-JC001 Communications Unit is required to connect to a Digital Operator (JUSP-OP05A-1-E).

Item		Specification	
	1:N Communi- cations	Up to N = 15 stations possible for RS-422A port	
	Axis Address Setting	Set with parameters.	
	USB Communi- cations (CN7)	Interface	Personal computer (with SigmaWin+) The software version of the SigmaWin+ must be version 7.28 or higher.
		Communica- tions Standard	Conforms to USB2.0 standard (12 Mbps).
Displays/Indicators		CHARGE, PWR, RUN, ERR, and L/A (A and B) indicators, and one-digit seven-segment display	
PROFINET Communica- tions	Communication profile	PROFINET IO RT/IRT Top (High Performance) Ver 2.3 (IRT is not supported)	
	Applicable Communications Standards	IEC 61158 Type 12, IEC 61800-7 PROFIdrive Drive Profile	
	Physical Layer	100BASE-TX (IEEE 802.3)	
	Communications Connectors	CN6A (RJ45): PROFINET signal input connector CN6B (RJ45): PROFINET signal output connector Full duplex , Auto-negotiation, Auto-crossover	
	Cable	Category 5, 4 shielded twisted pairs * The cable is automatically detected with AUTO MDIX.	
	Baud Rate Setting	100 MBit/s	
	Supported Protocols	<ul style="list-style-type: none"> ■ RTC – Real time Cyclic Protocol - RT Class 1 (unsynchron-ized) ■ RTA – Real time Acyclic Protocol ■ DCP – Discovery and Configuration Protocol ■ CL-RPC – Connectionless Remote Procedure Call ■ LLDP – Link Layer Discovery Protocol ■ SNMP – Simple Network Management Protocol 	
	Node Address Setting	DCP	
	Identification & Maintenance func- tions	I&M0-3	
	Topology recognition	LLDP, SNMP V1, MIB2	
	LED indicator	Red (ERR), Green (RUN), 2x PROFINET (Link/Activity)	
	Node type	IO-Device	
	Acyclic parameter access	Base Mode Parameter Access (Read/Write Record)	
	Cyclic messaging	Set of pre-defined Standard telegram: ST1, ST2, ST7, ST8, ST9 Manufacture telegram: Telegram number 100 Dynamic telegram mapping with max. 16 signal entries each (input, output): Telegram number 999	
Alarm Notification PDU	Optional		
Device Profile	Standard	IEC 61800-7-1/2/3	
	Motor type	Servo	

Item	Specification
<p>Axis Type</p> <p>Profile Services</p> <p>Application Classes</p>	<p>Rotary, Linear</p>
	<p>Cyclic messaging</p> <p>Acyclic parameter access mechanism.</p> <p>Identification & Maintenance functions (I&M0)</p> <p>Diagnostic and alarm mechanism</p> <p>Fault buffer mechanism</p>
	<p>1, 3</p>
<p>Drive Profile</p>	<ul style="list-style-type: none"> ■ PROFIdrive Profile Velocity mode Motion Profile type: Linear ■ PROFIdrive Profile Position mode Absolute and relative positioning Supported PROFIdrive position submodes: <ul style="list-style-type: none"> • MDI submode • Program submode (up to 64 positioning sets) Motion profile type: Linear ■ Pole detection mode ■ Profile Torque Mode Motion Profile type: Linear ■ Homing Function <ul style="list-style-type: none"> • Homing on negative limit switch (with/without index pulse) • Homing on positive limit switch (with/without index pulse) • Homing on negative home switch (with/without index pulse) • Homing on positive home switch (with/without index pulse) • Homing on index pulse • Homing on current position Motion profile type: Linear ■ Touch Probe Function ■ Torque Limit Function
<p>Analog Monitor (CN5)</p>	<p>Number of points: 2</p> <p>Output voltage range: ±10 VDC (effective linearity range: ±8 V)</p> <p>Resolution: 16 bits</p> <p>Accuracy: ±20 mV (Typ)</p> <p>Maximum output current: ±10 mA</p> <p>Settling time (±1%): 1.2 ms (Typ)</p>
<p>Dynamic Brake (DB)</p>	<p>Activated when a servo alarm or overtravel (OT) occurs, or when the power supply to the main circuit or servo is OFF.</p>
<p>Regenerative Processing</p>	<p>Built-in (An external resistor must be connected to the SGD7S-470A to -780A.)</p> <p>Refer to the following manual for details.</p> <p> Σ-7-Series AC Servo Drive Peripheral Device Selection Manual (Manual No.: SIEP S800001 32)</p>
<p>Overtravel (OT) Prevention</p>	<p>Stopping with dynamic brake, deceleration to a stop, or coasting to a stop for the P-OT (Forward Drive Prohibit) or N-OT (Reverse Drive Prohibit) signal</p>

Item		Specification
Protective Functions		Overcurrent, overvoltage, low voltage, overload, regeneration error, etc.
Utility Functions		Gain adjustment, alarm history, jogging, origin search, etc.
Safety Functions	Inputs	/HWBB1 and /HWBB2: Base block signals for Power Modules
	Output	EDM1: Monitors the status of built-in safety circuit (fixed output).
	Applicable Standards*3	ISO13849-1 PLe (category 3), IEC61508 SIL3
Applicable Option Modules		Fully-closed Modules <ul style="list-style-type: none"> ■ SGDV-OFB01A ■ SGDV-OFB03A ■ SGDV-OFB04A ■ SGDV-OFA01A Safety Modules <ul style="list-style-type: none"> ■ Σ-7 200 V: SGDV-OSA01A Note: You cannot use a Fully-closed Module and a Safety Module together.

*1. If you combine a Σ-7-Series SERVOPACK with a Σ-V-Series Option Module, the following Σ-V-Series SERVOPACKs specifications must be used: a surrounding air temperature of 0°C to 55°C and an altitude of 1,000 m max. Also, the applicable surrounding range cannot be increased by derating.

*2. The coefficient of speed fluctuation for load fluctuation is defined as follows:

$$\text{Coefficient of speed fluctuation} = \frac{\text{No-load motor speed} - \text{Total-load motor speed}}{\text{Rated motor speed}} \times 100\%$$

Fig. 16: Coefficient of speed fluctuation - Formula

*3. Always perform risk assessment for the system and confirm that the safety requirements are met.

3.3 Block Diagrams

SGD7S-R70A, -R90A, and -1R6A

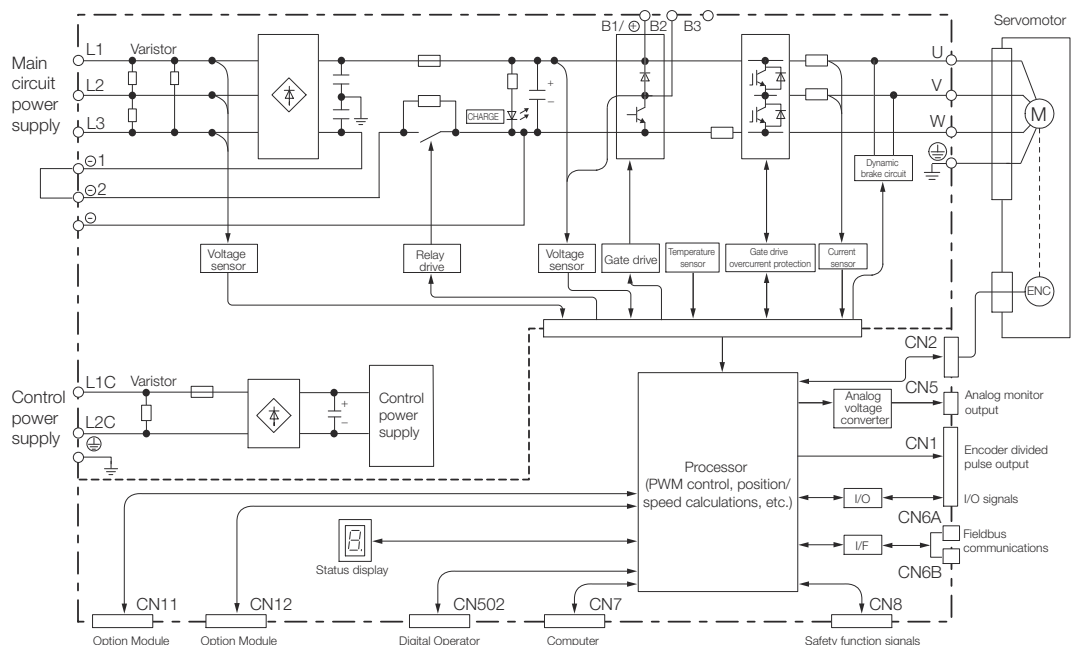


Fig. 17: Block Diagram - SGD7S-R70A, -R90A, and -1R6A

Block Diagrams

SGD7S-2R8A

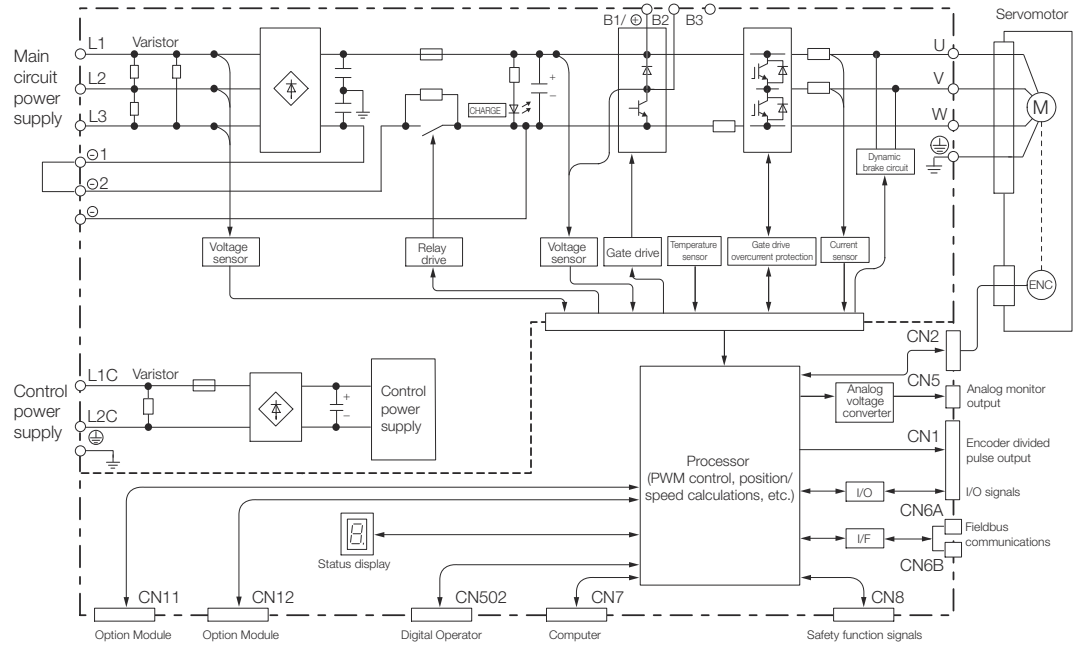


Fig. 18: Block Diagram - SGD7S-2R8A

SGD7S-3R8A, -5R5A, and -7R6A

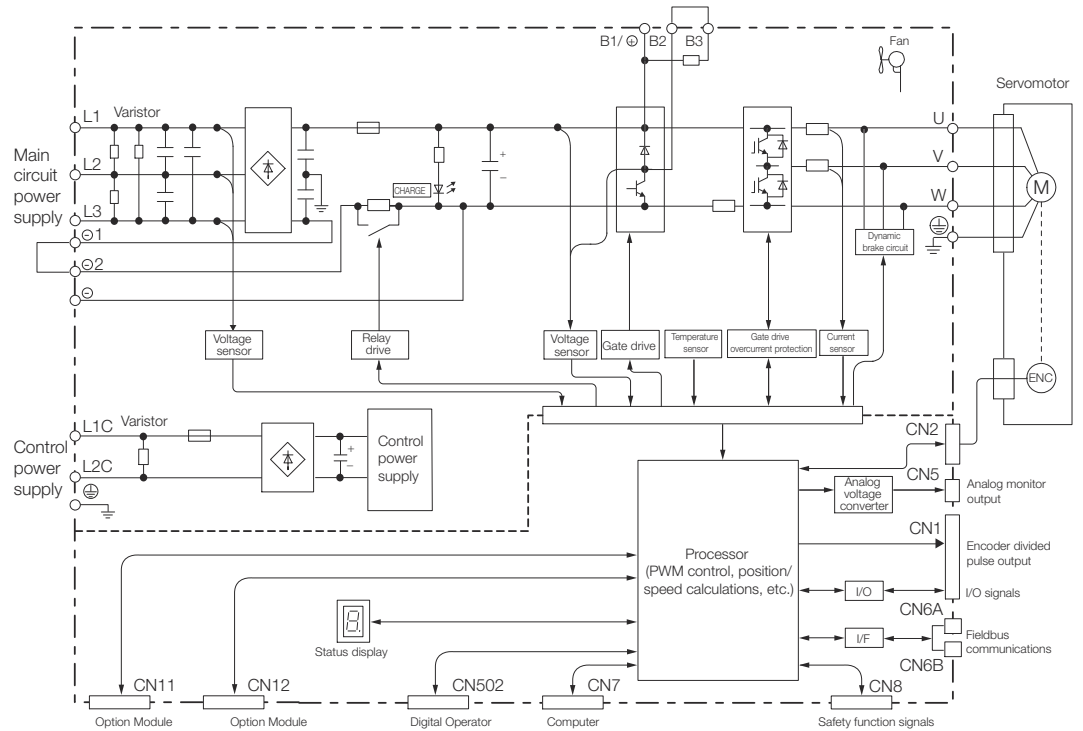


Fig. 19: Block Diagram - SGD7S-3R8A, -5R5A, and -7R6A

SGD7S-120A

Standard Specifications: Three-Phase, 200-VAC Power Supply Input

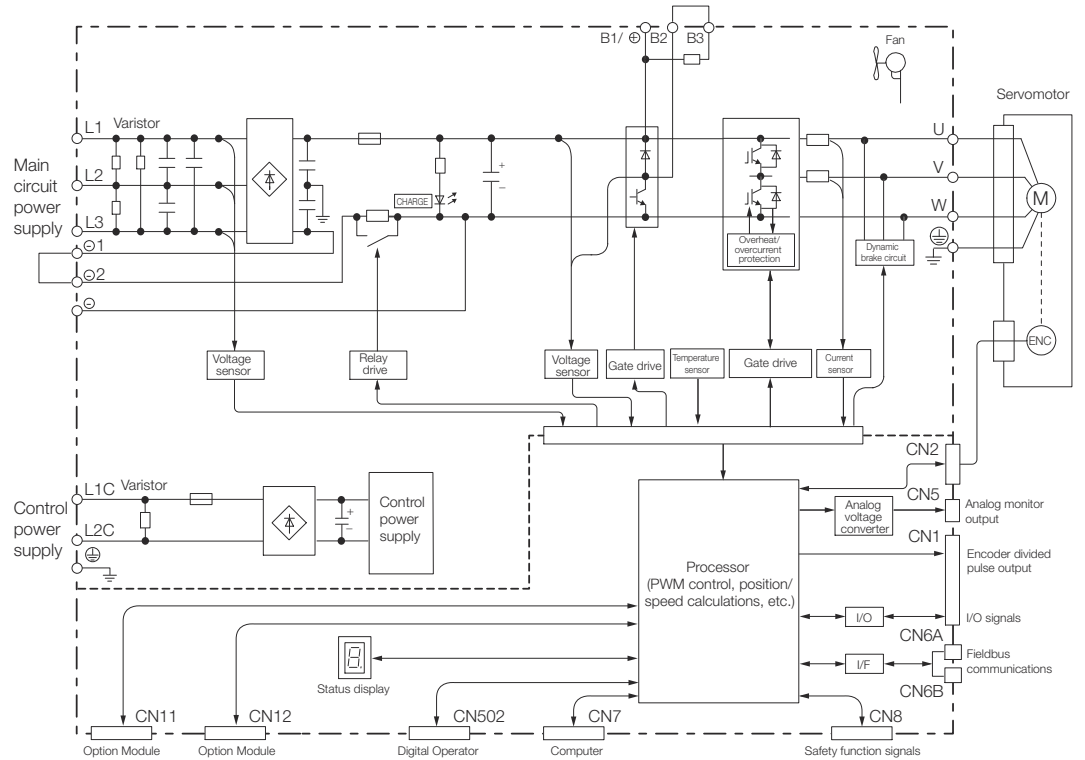


Fig. 20: Block Diagram - SGD7S-120A, Standard Specifications

Optional Specifications: Single-Phase, 200-VAC Power Supply Input (SERVOPACK Model: SGD7S-120AA0A008)

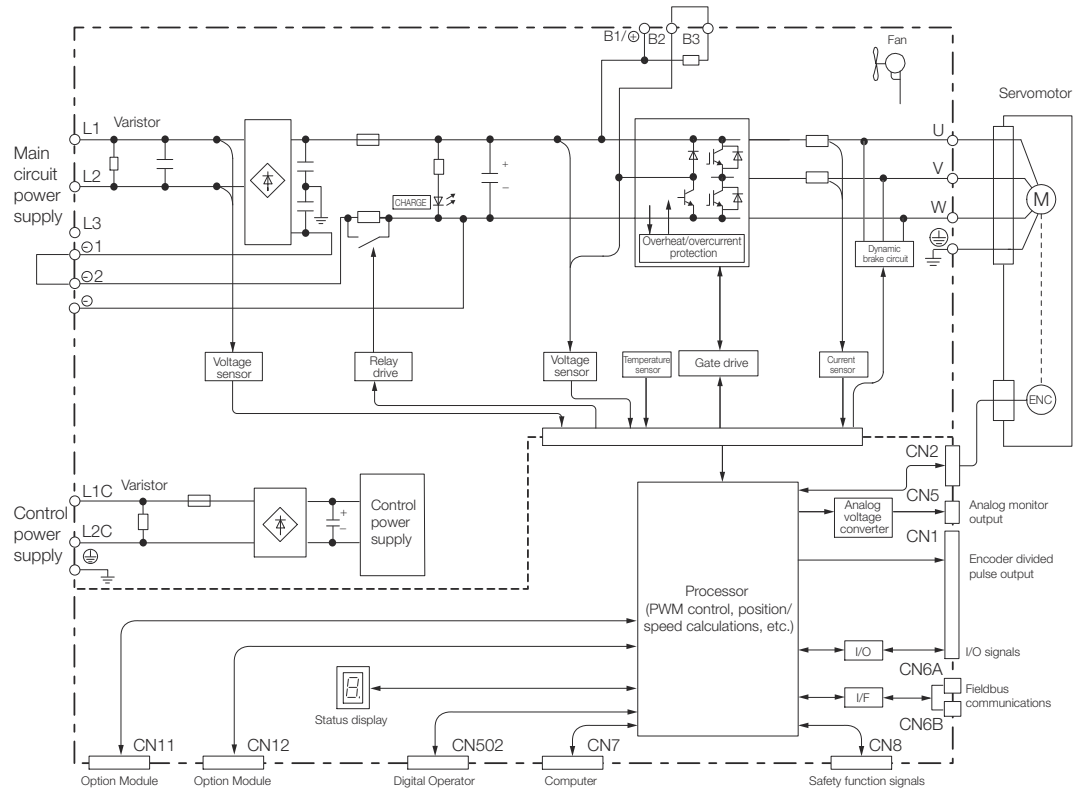


Fig. 21: Block Diagram - SGD7S-120A, Optional Specifications (SERVOPACK Model: SGD7S-120AA0A008)

3.4 External Dimensions

3.4.1 Front Cover Dimensions and Connector Specifications

The front cover dimensions and panel connector section are the same for all models. Refer to the following figures and table.

Front Cover Dimensions

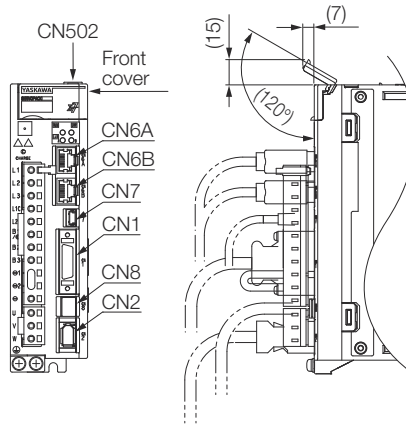


Fig. 22: External Dimensions SGD7S - Front Cover Dimensions and Connectors

Connector Specifications

Connector No.	Model	Number of Pins	Manufacturer
CN1	10226-59A3MB	26	3M Japan Limited
CN2	3E106-0220KV	6	3M Japan Limited
CN502	S8B-ZR-SM4ATF(LF)(SN)	8	J.S.T. Mfg. Co., Ltd.
CN6A/B	1903815-1	8	Tyco Electronics Japan G.K.
CN7	2172034-1	5	Tyco Electronics Japan G.K.
CN8	1981080-1	8	Tyco Electronics Japan G.K.

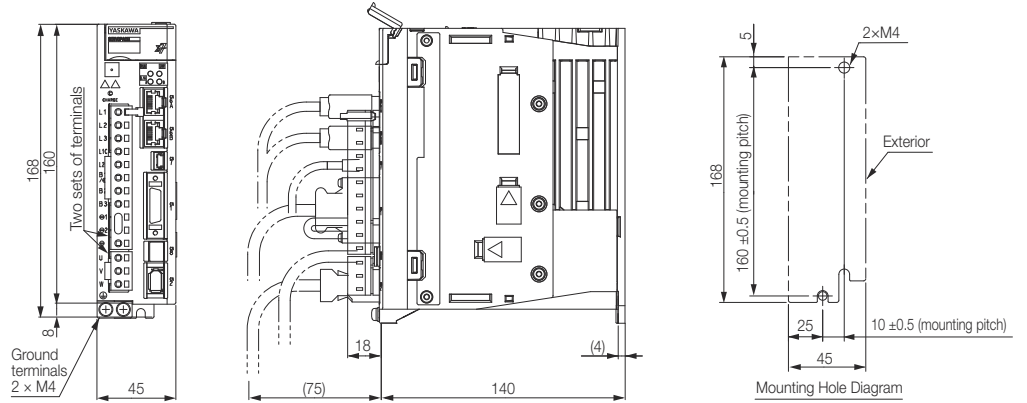


The above connectors or their equivalents are used for the SERVO-PACKs.

3.4.2 SERVOPACK External Dimensions

3.4.2.1 Base-mounted SERVOPACKs

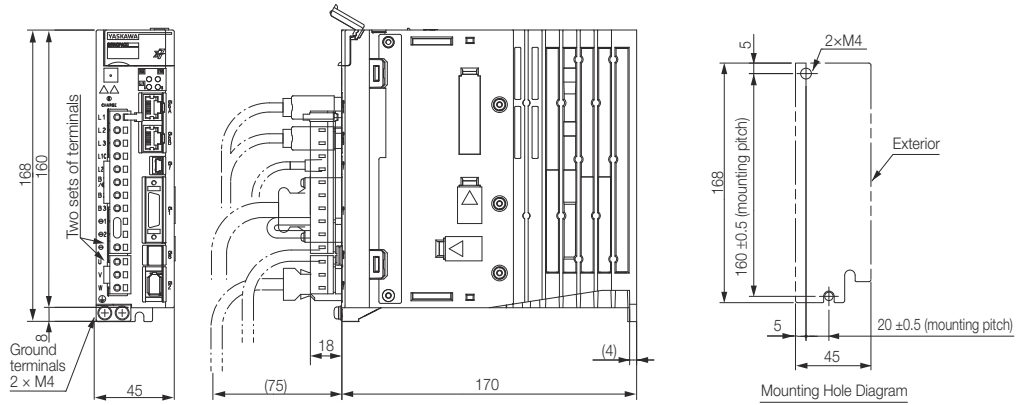
Three-phase, 200 VAC:
SGD7S-R70A, -R90A, and
-1R6A



Approx. mass: 0.8 kg
Unit: mm

Fig. 23: External Dimensions Base-mounted SERVOPACKs - Three-phase, 200 VAC: SGD7S-R70A, -R90A, and -1R6A

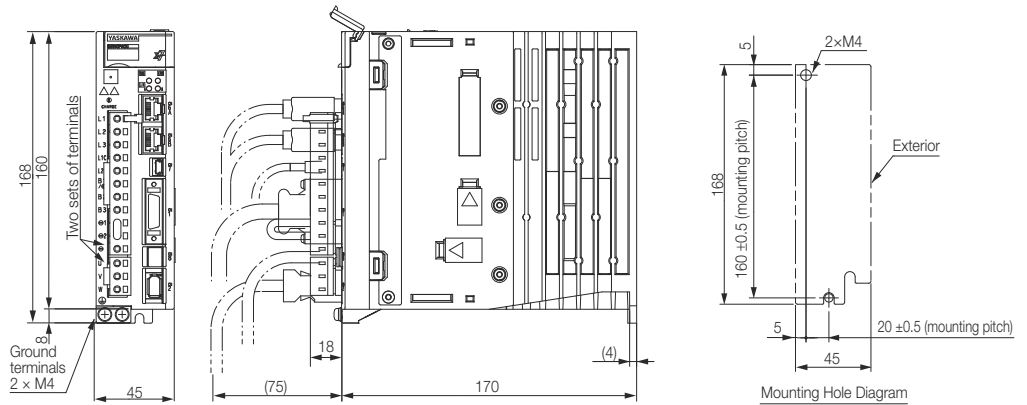
Three-phase, 200 VAC: SGD7S-2R8A; Single-Phase, 100 VAC: SGD7S-R70F, -R90F, and -2R1F



Approx. mass: 1.0 kg
Unit: mm

Fig. 24: External Dimensions Base-mounted SERVOPACKs - Three-phase, 200 VAC: SGD7S-2R8A; Single-Phase, 100 VAC: SGD7S-R70F, -R90F, and -2R1F

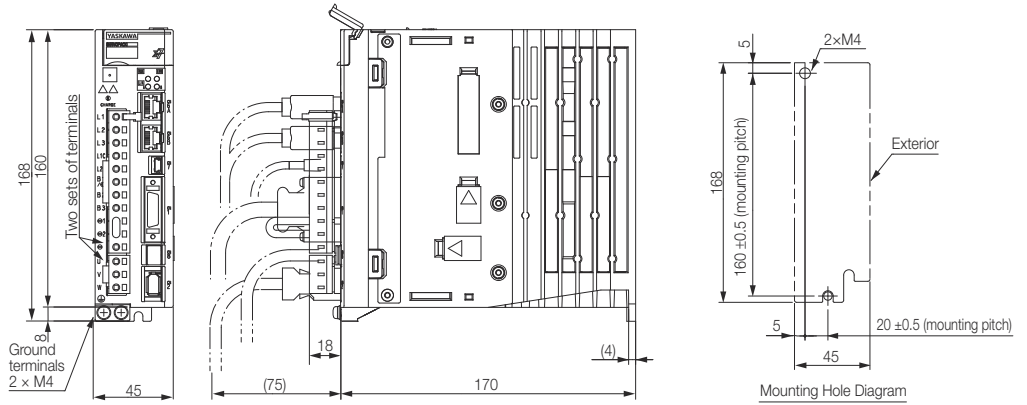
Three-phase, 200 VAC: SGD7S-3R8A, -5R5A, and -7R6A; Single-Phase, 100 VAC: SGD7S-2R8F



Approx. mass: 1.0 kg
Unit: mm

Fig. 25: External Dimensions Base-mounted SERVOPACKs - Three-phase, 200 VAC: SGD7S-3R8A, -5R5A, and -7R6A; Single-Phase, 100 VAC: SGD7S-2R8F

**Three-phase, 200 VAC:
SGD7S-120A**



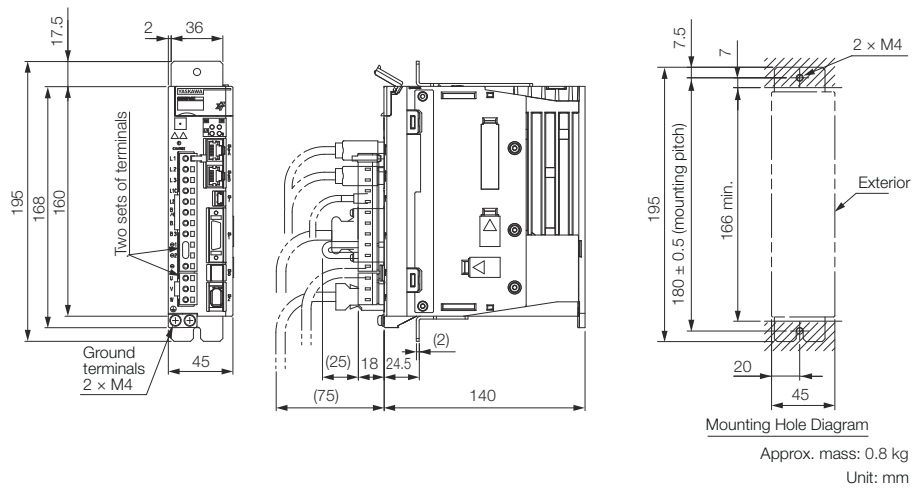
Approx. mass: 1.0 kg
Unit: mm

Fig. 26: External Dimensions Base-mounted SERVOPACKs - Three-phase, 200 VAC: SGD7S-120A

3.4.2.2 Rack-mounted SERVOPACKs

Hardware Option Code: 001

**Three-phase, 200 VAC:
SGD7S-R70A, -R90A, and
-1R6A**



Approx. mass: 0.8 kg
Unit: mm

Fig. 27: External Dimensions Rack-mounted SERVOPACKs - Three-phase, 200 VAC: SGD7S-R70A, -R90A, and -1R6A

**Three-phase, 200 VAC:
SGD7S-2R8A**

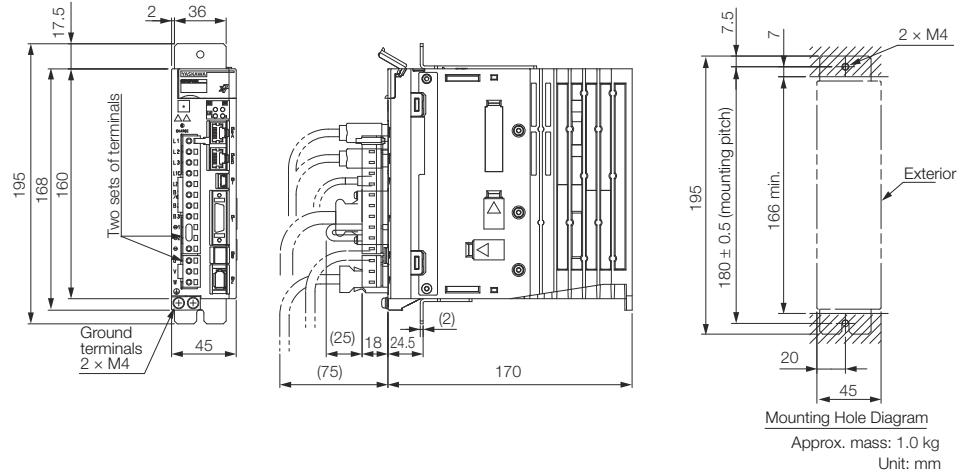


Fig. 28: External Dimensions Rack-mounted SERVOPACKs - Three-phase, 200 VAC: SGD7S-2R8A

**Three-phase, 200 VAC:
SGD7S-3R8A, -5R5A, and
-7R6A**

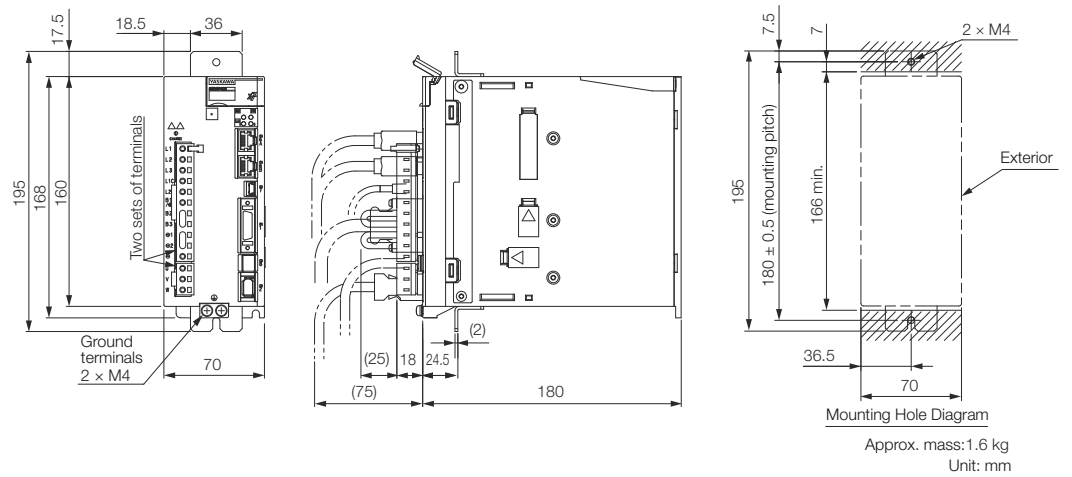


Fig. 29: External Dimensions Rack-mounted SERVOPACKs - Three-phase, 200 VAC: SGD7S-3R8A, -5R5A, and -7R6A

**Three-phase, 200 VAC:
SGD7S-120A**

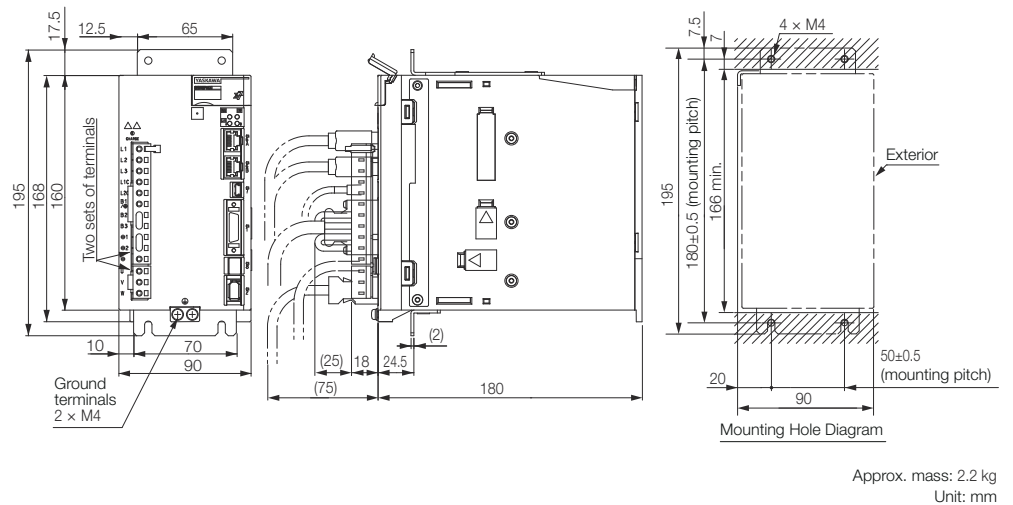


Fig. 30: External Dimensions Rack-mounted SERVOPACKs - Three-phase, 200 VAC: SGD7S-120A

3.5 Examples of Standard Connections between SERVOPACKs and Peripheral Devices

Rotary Servomotors

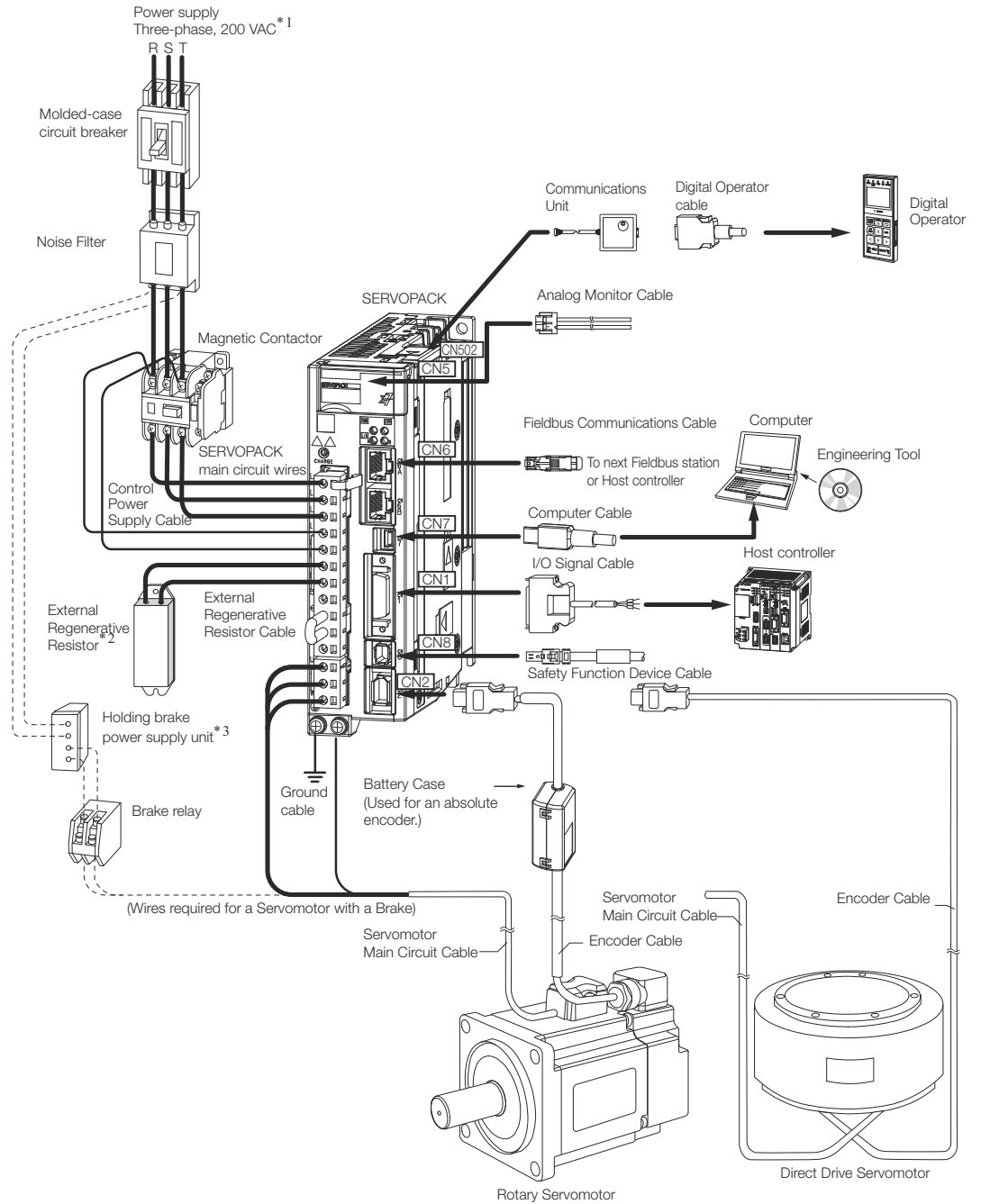


Fig. 31: Examples of Standard Connections between SERVOPACKs and Peripheral Devices - SGD7S 200V - Rotary Servomotors

*1. This example is for a SERVOPACK with a three-phase, 200-VAC power supply input. The pin layout of the main circuit connector depends on the voltage.

*2. External Regenerative Resistors are not provided by Yaskawa.

*3. The power supply for the holding brake is not provided by Yaskawa. Select a power supply based on the holding brake specifications.

If you use a 24-V brake, install a separate power supply for the 24-VDC power supply from other power supplies, such as the one for the I/O signals of the CN1 connector.

If the power supply is shared, the I/O signals may malfunction.

Examples of Standard Connections between SERVOPACKs and Peripheral Devices

Linear Servomotors

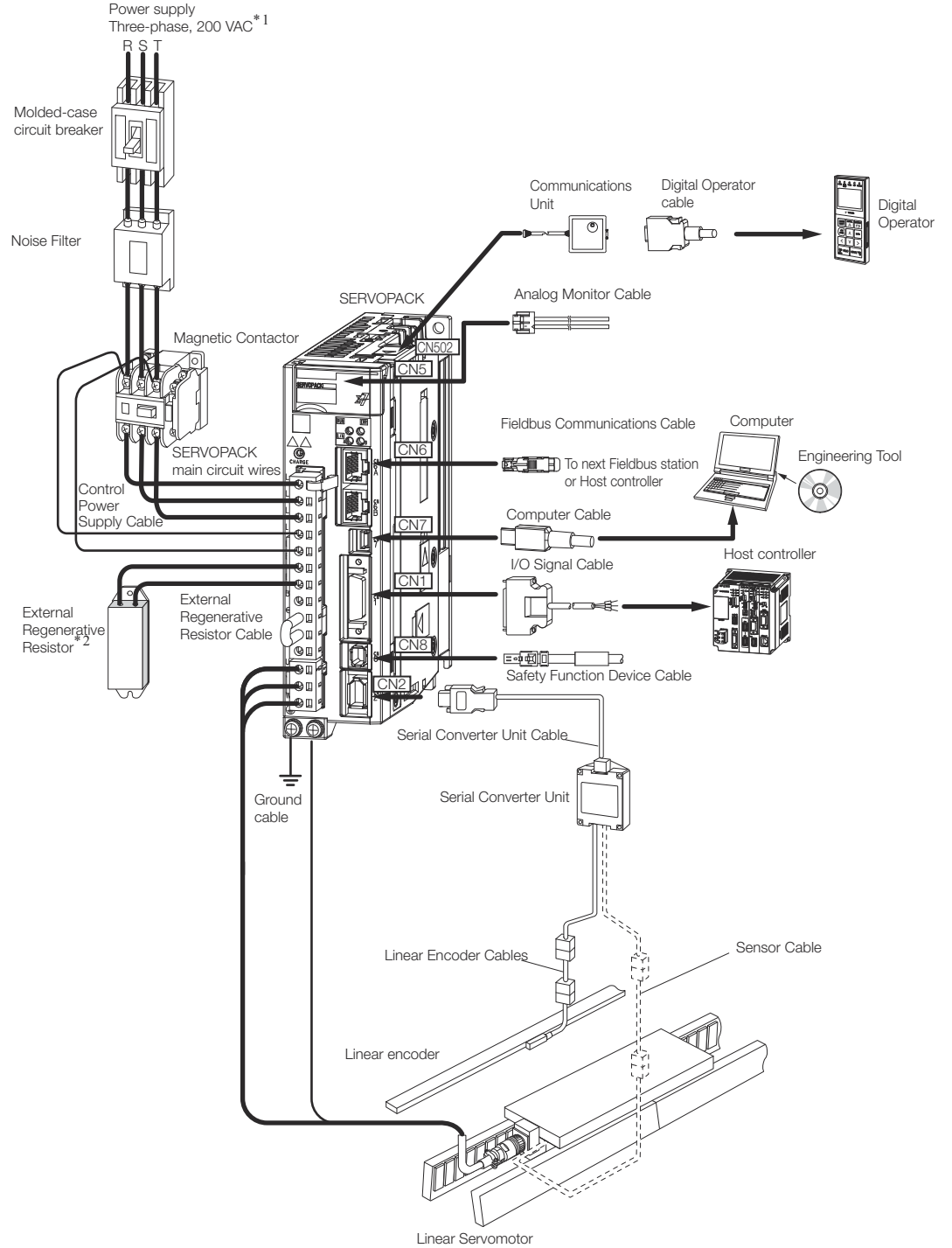


Fig. 32: Examples of Standard Connections between SERVOPACKs and Peripheral Devices - SGD7S 200V - Linear Servomotors

*1. This example is for a SERVOPACK with a three-phase, 200-VAC power supply input. The pin layout of the main circuit connector depends on the voltage.

*2. External Regenerative Resistors are not provided by Yaskawa.

4 SERVOPACK Installation

4.1 Overview

This chapter provides information on installing SERVOPACKs in the required locations.

4.2 Installation Precautions

Refer to the following section for the ambient installation conditions.

→ [Chap. 3.2.3 'Specifications' ...page 60](#)

- **Installation Near Sources of Heat**
Implement measures to prevent temperature increases caused by radiant or convection heat from heat sources so that the ambient temperature of the SERVOPACK meets the ambient conditions.
- **Installation Near Sources of Vibration**
Install a vibration absorber on the installation surface of the SERVOPACK so that the SERVOPACK will not be subjected to vibration.
- **Other Precautions**
Do not install the SERVOPACK in a location subject to high temperatures, high humidity, water drops, cutting oil, excessive dust, excessive dirt, excessive iron powder, corrosive gasses, or radioactivity.

4.3 Mounting Types and Orientation

The SERVOPACKs come in the following mounting types: base-mounted, rack-mounted, and duct-ventilated types. Regardless of the mounting type, mount the SERVOPACK vertically, as shown in the following figures.

Also, mount the SERVOPACK so that the front panel is facing toward the operator.



Prepare two to four mounting holes for the SERVOPACK and mount it securely in the mounting holes. (The number of mounting holes depends on the capacity of the SERVOPACK.)

Base-mounted SERVO- PACK

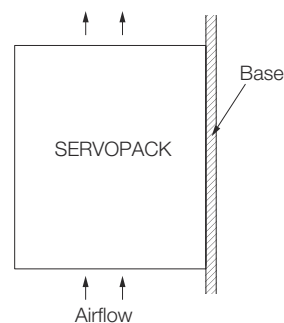


Fig. 33: Base Mounting of the SERVOPACK

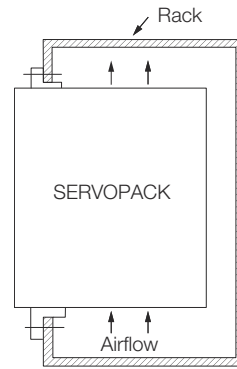
**Rack-mounted SERVO-
PACK**

Fig. 34: Rack Mounting of the SERVOPACK

4.4 Mounting Hole Dimensions

Use mounting holes to securely mount the SERVOPACK to the mounting surface.



To mount the SERVOPACK, you will need to prepare a screwdriver that is longer than the depth of the SERVOPACK.

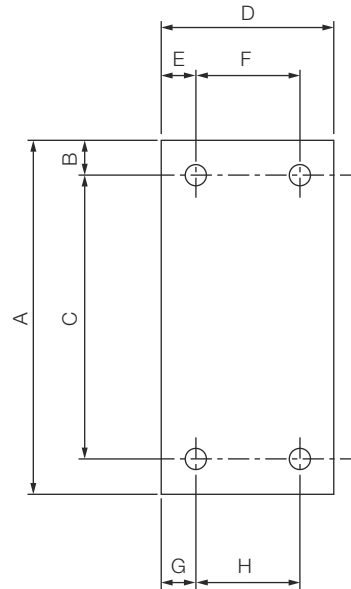


Fig. 35: Mounting Hole Dimensions of the SERVOPACK

■ Σ-7-series Mounting Hole Dimensions

SERVOPACK Model		Dimensions (mm)								Screw Size	Number of Screws
		A	B	C	D	E	F	G	H		
SGD7S-	R70A, R90A, 1R6A	168	5	160 ±0.5	45	35	-	25	-	M4	2
	2R8A, R70F, R90F, 2R1F	168	5	160 ±0.5	45	5	-	25	-	M4	2
	3R8A, 5R5A, 7R6A, 2R8F	168	5	160 ±0.5	70	6	58 ±0.5	64	-	M4	3
	120A	168	5	160 ±0.5	90	5	80 ±0.5	12.5	-	M4	3
	180A, 200A, 120A□ □□008	188	5	180 ±0.5	100	95	-	12.5	75 ±0.5	M4	3
	330A	258	6	250 ±0.5	110	5	100 ±0.5	13	84 ±0.5	M5	4
	470A, 550A	315	6	302.5 ±0.5	170	14	142 ±0.5	14	142 ±0.5	M6	4
	590A, 780A	390	7.5	375 ±0.5	260	30	200 ±0.5	30	200 ±0.5	M6	4

■ Σ -V-series-Compatible Mounting Hole Dimensions

If you are replacing a Σ -V-Series SERVOPACK with a Σ -7-Series SERVOPACK, you can also use the mounting holes that were used for the Σ -V-Series SERVOPACK. Refer to the following table.

SERVOPACK Model		Dimensions (mm)								Screw Size	Number of Screws
		A	B	C	D	E	F	G	H		
SGD7S-	R70A, R90A, 1R6A	168	5	150 ±0.5	45	35	–	35	–	M4	2
	2R8A, R70F, R90F, 2R1F	168	5	150 ±0.5	45	5	–	35	–	M4	2
	3R8A, 5R5A, 7R6A, 2R8F	168	5	150 ±0.5	70	6	58 ±0.5	6	–	M4	3
	120A	168	5	150 ±0.5	90	5	80 ±0.5	5	–	M4	3
	180A, 200A, 120A□ □□008	188	5	170 ±0.5	100	95	–	5	90 ±0.5	M4	3
	330A	250	6	238.5 ±0.5	110	5	100 ±0.5	5	100 ±0.5	M5	4
	470A, 550A, 590A, 780A	A special attachment is required. Contact your Yaskawa representative for details.									

4.5 Mounting Interval

4.5.1 Installing One SERVOPACK in a Control Panel

Provide the following spaces around the SERVOPACK.

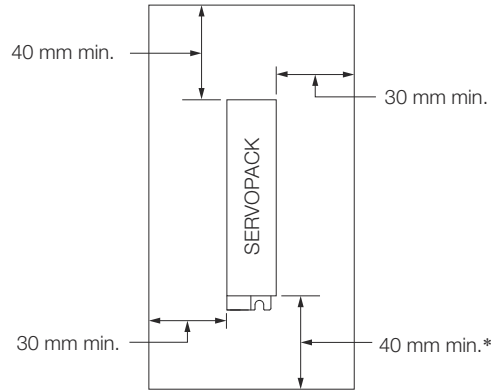


Fig. 36: Mounting Spaces around the SERVOPACK

* For this dimension, ignore items protruding from the main body of the SERVOPACK.

4.5.2 Installing More Than One SERVOPACK in a Control Panel

Provide the following intervals between the SERVOPACKs and spaces around the SERVOPACKs.



Install cooling fans above the SERVOPACKs so that hot spots do not occur around the SERVOPACKs. Provide sufficient intervals and spaces as shown in the following figure to enable cooling by the fans and natural convection.

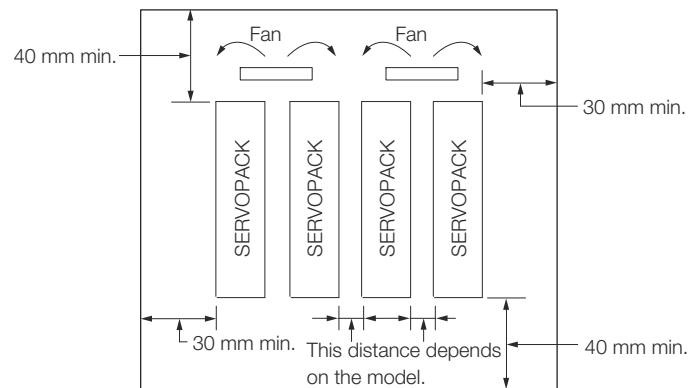


Fig. 37: Mounting Spaces around the SERVOPACK when Installing More Than One SERVOPACK in a Control Panel

The space required on the right side of a SERVOPACK (when looking at the SERVOPACK from the front) depends on the SERVOPACK models. Refer to the following table.

SERVOPACK model		Space on Right Side	Cooling Fan Installation Conditions
			10 mm above SERVOPACK's Top Surface
SGD7S-	R70A, R90A, 1R6A, 2R8A, 3R8A, 5R5A, 7R6A, R70F, R90F, 2R1F, 2R8F	1 mm min.	Air speed: 1.0 m/s min.

SERVOPACK model		Space on Right Side	Cooling Fan Installation Conditions
			10 mm above SERVOPACK's Top Surface
120A, 180A, 200A, 330A, 470A, 550A, 590A, 780A		10 mm min.	Air speed: 1.0 m/s min.

4.6 Monitoring the Installation Environment

You can use the SERVOPACK Installation Environment Monitor parameter to check the operating conditions of the SERVOPACK in the installation environment.

You can check the SERVOPACK installation environment monitor with either of the following methods.

- Using the SigmaWin+: **Life Monitor - Installation Environment Monitor - SERVOPACK**
- Panel Operator or Digital Operator: Un025 (Installation Environment Monitor [%])

Implement one or more of the following actions if the monitor value exceeds 100%.

- Lower the surrounding temperature.
- Decrease the load.



The value of the SERVOPACK Installation Environment Monitor parameter will increase by about 10% for each 10°C increase in the ambient temperature.



Always observe the surrounding air temperature given in the SERVOPACK environment conditions. Even if the monitor value is 100% or lower, you cannot use a SERVOPACK in a location that exceeds the specified surrounding air temperature.

4.7 Derating Specifications

If you use the SERVOPACK at a surrounding air temperature of 55°C to 60°C or at an altitude of 1,000 m to 2,000 m, you must apply the derating rates given in the following graphs.

SGD7S-R70A, -R90A, -1R6A, -2R8A, -R70F, -R90F, -2R1F, and -2R8F

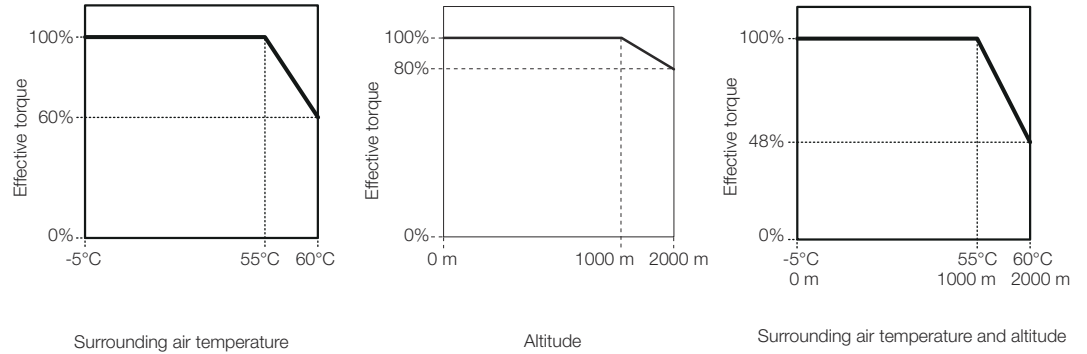


Fig. 38: Derating SGD7S-R70A, -R90A, -1R6A, -2R8A, -R70F, -R90F, -2R1F, and -2R8F

SGD7S-3R8A, -5R5A, -7R6A, -120A, -180A, -200A, -330A, -470A, -550A, -590A, and -780A

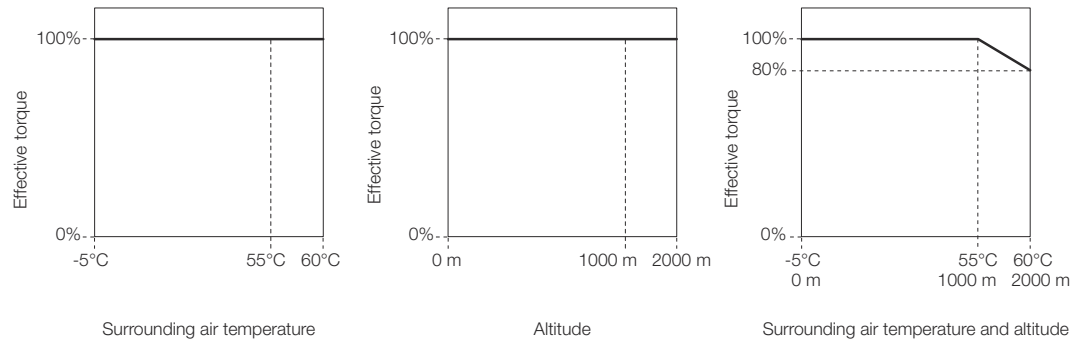


Fig. 39: Derating SGD7S-3R8A, -5R5A, -7R6A, -120A, -180A, -200A, -330A, -470A, -550A, -590A, and -780A

4.8 EMC Installation Conditions

This section gives the installation conditions that were used for EMC certification testing.

The EMC installation conditions that are given here are the conditions that were used to pass testing criteria at Yaskawa. The EMC level may change under other conditions, such as the actual installation structure and wiring conditions. These Yaskawa products are designed to be built into equipment. Therefore, you must implement EMC measures and confirm compliance for the final equipment.

The applicable standards are EN 55011 group 1 class A, EN 61000-6-2, EN 61000-6-4, and EN 61800-3 (category C2, second environment).

Three-Phase, 200 VAC

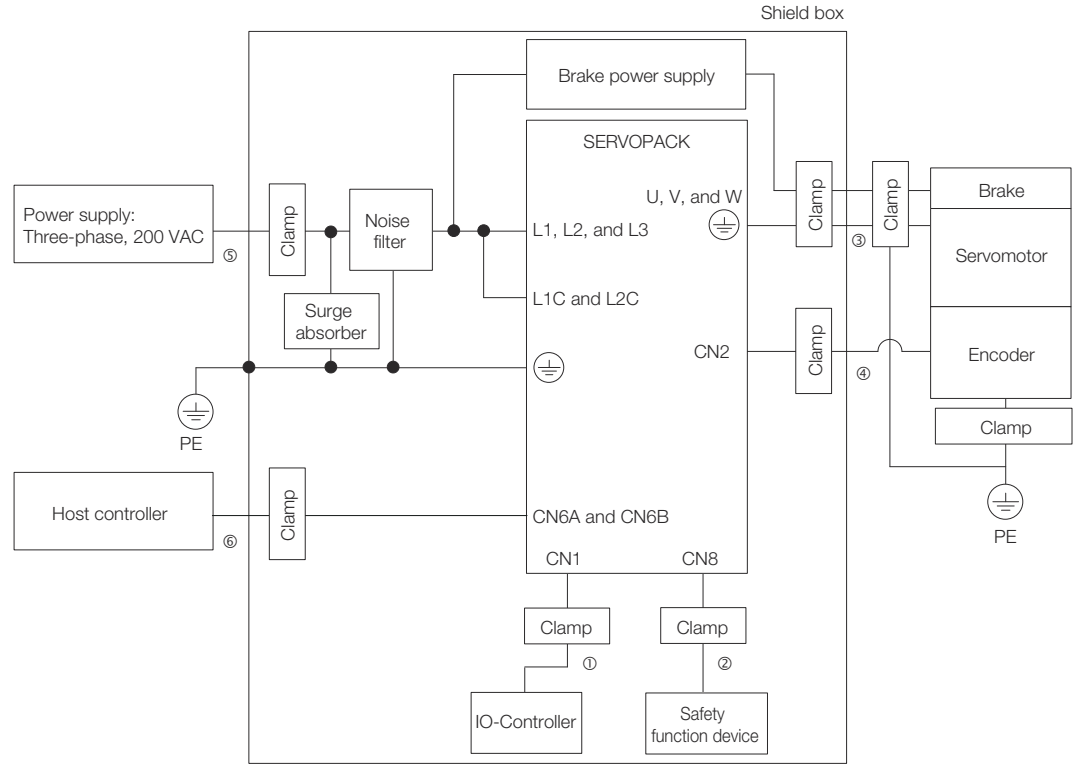


Fig. 40: EMC Installation Conditions - Three-Phase, 200 VAC

Symbol	Cable Name	Specification
1	I/O Signal Cable	Shielded cable
2	Safety Function Device Cable	Shielded cable
3	Servomotor Main Circuit Cable	Shielded cable
4	Encoder Cable	Shielded cable
5	Main Circuit Power Supply Cable	Shielded cable
6	PROFINET Communications Cable	Shielded cable

Single-Phase, 200 VAC

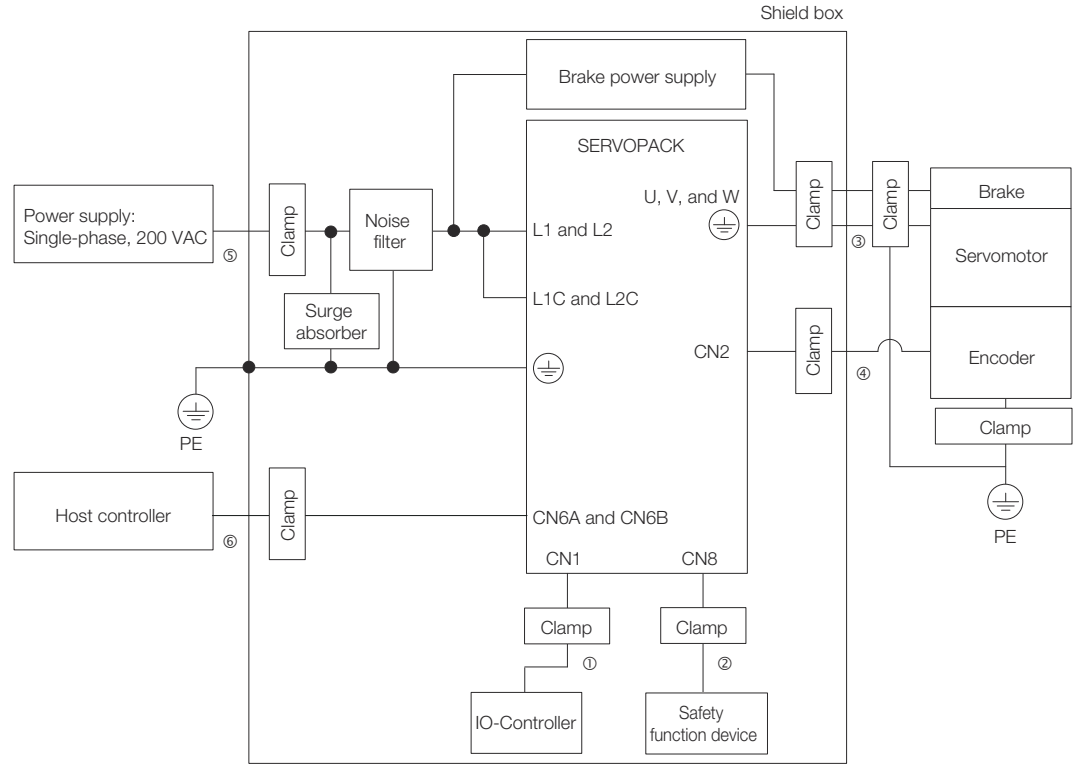


Fig. 41: EMC Installation Conditions - Single Phase, 200 VAC

Symbol	Cable Name	Specification
1	I/O Signal Cable	Shielded cable
2	Safety Function Device Cable	Shielded cable
3	Servomotor Main Circuit Cable	Shielded cable
4	Encoder Cable	Shielded cable
5	Main Circuit Power Supply Cable	Shielded cable
6	PROFINET Communications Cable	Shielded cable

5 Wiring and Connecting SERVOPACKs

5.1 Overview

This chapter provides information on wiring and connecting SERVOPACKs to power supplies and peripheral devices.

5.2 Wiring and Connecting SERVOPACKs

5.2.1 General Precautions

Wiring Precautions



DANGER

Do not change any wiring while power is being supplied.

There is a risk of electric shock or injury.



WARNING

- **Wiring and inspections must be performed only by qualified engineers.**
There is a risk of electric shock or product failure.
- **Check all wiring and power supplies carefully.**
Incorrect wiring or incorrect voltage application to the output circuits may cause short-circuit failures. If a short-circuit failure occurs as a result of any of these causes, the holding brake will not work. This could damage the machine or cause an accident that may result in death or injury.
- **Connect the AC and DC power supplies to the specified SERVOPACK terminals.**
 - Connect an AC power supply to the L1, L2, and L3 terminals and the L1C and L2C terminals on the SERVOPACK.
 - Connect a DC power supply to the B1/⊕ and ⊖2 terminals and the L1C and L2C terminals on the SERVOPACK.
There is a risk of failure or fire.
- **If you use a SERVOPACK with the Dynamic Brake Hardware Option, connect an External Dynamic Brake Resistor that is suitable for the machine and equipment specifications to the specified terminals.**
There is a risk of unexpected operation, machine damage, burning, or injury when an emergency stop is performed.

**CAUTION**

- **Wait for at least six minutes after turning OFF the power supply (with a SERVOPACK for a 100-VAC power supply input, wait for at least nine minutes) and then make sure that the CHARGE indicator is not lit before starting wiring or inspection work. Do not touch the power supply terminals while the CHARGE lamp is lit after turning OFF the power supply because high voltage may still remain in the SERVOPACK.**

There is a risk of electric shock.

- **Observe the precautions and instructions for wiring and trial operation precisely as described in this document.**

Failures caused by incorrect wiring or incorrect voltage application in the brake circuit may cause the SERVOPACK to fail, damage the equipment, or cause an accident resulting in death or injury.

- **Check the wiring to be sure it has been performed correctly. Connectors and pin layouts are sometimes different for different models. Always confirm the pin layouts in technical documents for your model before operation.**

There is a risk of failure or malfunction.

- **Connect wires to power supply terminals and motor connection terminals securely with the specified methods and tightening torque.**

Insufficient tightening may cause wires and terminal blocks to generate heat due to faulty contact, possibly resulting in fire.

- **Use shielded twisted-pair cables or screened unshielded multi-twisted-pair cables for I/O Signal Cables and Encoder Cables.**

- **Observe the following precautions when wiring the SERVOPACK's main circuit terminals.**

- Turn ON the power supply to the SERVOPACK only after all wiring, including the main circuit terminals, has been completed.

- If a connector is used for the main circuit terminals, remove the main circuit connector from the SERVOPACK before you wire it.

- Insert only one wire per insertion hole in the main circuit terminals.

- When you insert a wire, make sure that the conductor wire (e.g., whiskers) does not come into contact with adjacent wires.

- **Install molded-case circuit breakers and other safety measures to provide protection against short circuits in external wiring.**

There is a risk of fire or failure.

**NOTICE**

- **Whenever possible, use the Cables specified by Yaskawa.**
If you use any other cables, confirm the rated current and application environment of your model and use the wiring materials specified by Yaskawa or equivalent materials.
- **Securely tighten cable connector screws and lock mechanisms.**
Insufficient tightening may result in cable connectors falling off during operation.
- **Do not bundle power lines (e.g., the Main Circuit Cable) and low-current lines (e.g., the I/O Signal Cables or Encoder Cables) together or run them through the same duct. If you do not place power lines and low-current lines in separate ducts, separate them by at least 30 cm.**
If the cables are too close to each other, malfunctions may occur due to noise affecting the low-current lines.
- **Install a battery at either the host controller or on the Encoder Cable.**
If you install batteries both at the host controller and on the Encoder Cable at the same time, you will create a loop circuit between the batteries, resulting in a risk of damage or burning.
- **When connecting a battery, connect the polarity correctly.**
There is a risk of battery rupture or encoder failure.



- *Use a molded-case circuit breaker or fuse to protect the main circuit. The SERVOPACK connects directly to a commercial power supply; it is not isolated through a transformer or other device. Always use a molded-case circuit breaker or fuse to protect the Servo System from accidents involving different power system voltages or other accidents.*
- *Install an earth leakage breaker. The SERVOPACK does not have a built-in ground fault protective circuit. To configure a safer system, install a ground fault detector against overloads and short-circuiting, or install a ground fault detector combined with a molded-case circuit breaker.*
- *Do not turn the power supply ON and OFF more than necessary.*
 - *Do not use the SERVOPACK for applications that require the power supply to turn ON and OFF frequently. Such applications will cause elements in the SERVOPACK to deteriorate.*
 - *After you have started actual operation, allow at least one hour between turning the power supply ON and OFF (as a guideline).*

To ensure safe, stable application of the servo system, observe the following precautions when wiring.

- Use the Cables specified by Yaskawa. Design and arrange the system so that each cable is as short as possible.
Refer to the following manual or catalog for information on the specified cables.
 - AC Servo Drives Σ -7 Series (Catalog No.: KAEP S800001 23)
 - Σ -7-Series Peripheral Device Selection Manual (Manual No.: SIEP S800001 32)
- The signal cable conductors are as thin as 0.2 mm² or 0.3 mm². Do not subject them to excessive bending stress or tension.

5.2.2 Countermeasures against Noise



The SERVOPACK is designed as an industrial device. It therefore provides no measures to prevent radio interference. The SERVOPACK uses high-speed switching elements in the main circuit. Therefore peripheral devices may be affected by switching noise.

If the equipment is to be used near private houses or if radio interference is a problem, take countermeasures against noise.

The SERVOPACK uses microprocessors. Therefore, it may be affected by switching noise from peripheral devices.

To prevent the noise from the SERVOPACK or the peripheral devices from causing malfunctions of any devices, take the following countermeasures against noise as required.

- Install the input reference device and Noise Filter as close to the SERVOPACK as possible.
- Always install a Surge Absorber for relays, solenoids, and Magnetic Contactor coils.
- Do not place the following cables in the same duct or bundle them together. Also, separate the cables from each other by at least 30 cm.
 - Main Circuit Cables and I/O Signal Cables
 - Main Circuit Cables and Host Controller Cables
 - Main Circuit Cables and Encoder Cables
- Do not share the power supply with an electric welder or electrical discharge machine. If the SERVOPACK is placed near a high-frequency generator, install Noise Filters on the input side on the Main Circuit Power Supply Cable and Control Power Supply Cable even if the same power supply is not shared with the high-frequency generator. Refer to the following section for information on connecting Noise Filters.
[↪ 'Noise Filters' ...page 86](#)
- Implement suitable grounding measures. Refer to the following section for information on grounding measures.
[↪ Chap. 5.2.3 'Grounding' ...page 89](#)

Noise Filters

You must attach Noise Filters in appropriate places to protect the SERVOPACK from the adverse effects of noise. The following is an example of wiring for countermeasures against noise.

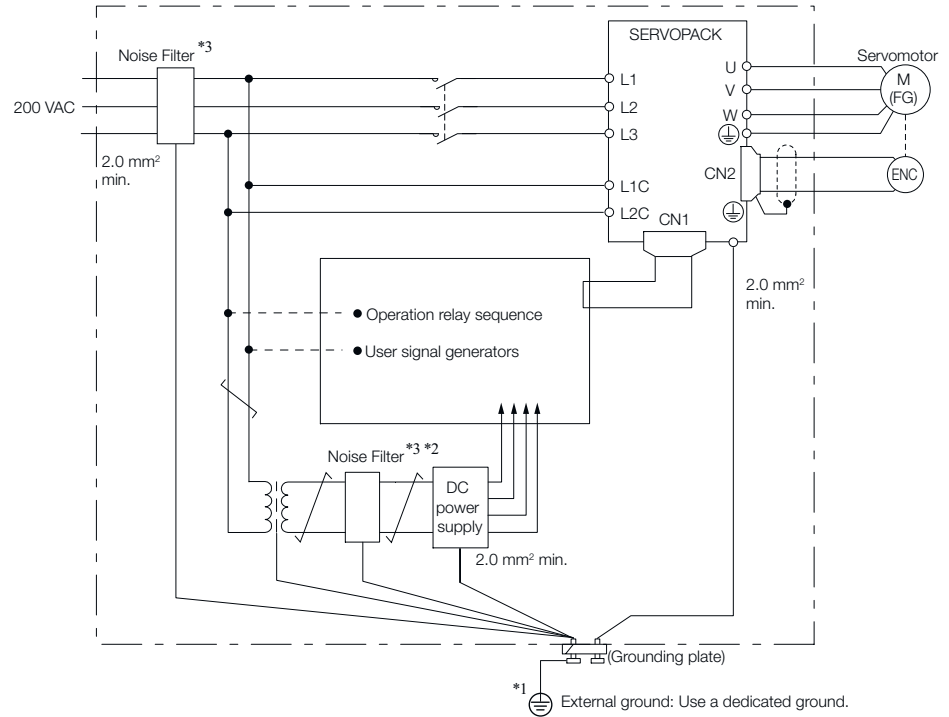


Fig. 42: Example for Noise Filter

- *1. For the ground wire, use a wire with a thickness of at least 2.0 mm² (preferably, flat braided copper wire).
- *2. Whenever possible, use twisted-pair wires to wire all connections marked with ∇ .
- *3. Refer to the following section for precautions when using Noise Filters.

➔ 'Noise Filter Wiring and Connection Precautions' ...page 87

Noise Filter Wiring and Connection Precautions

Always observe the following precautions when wiring or connecting Noise Filters.

- Separate input lines from output lines. Do not place input lines and output lines in the same duct or bundle them together.

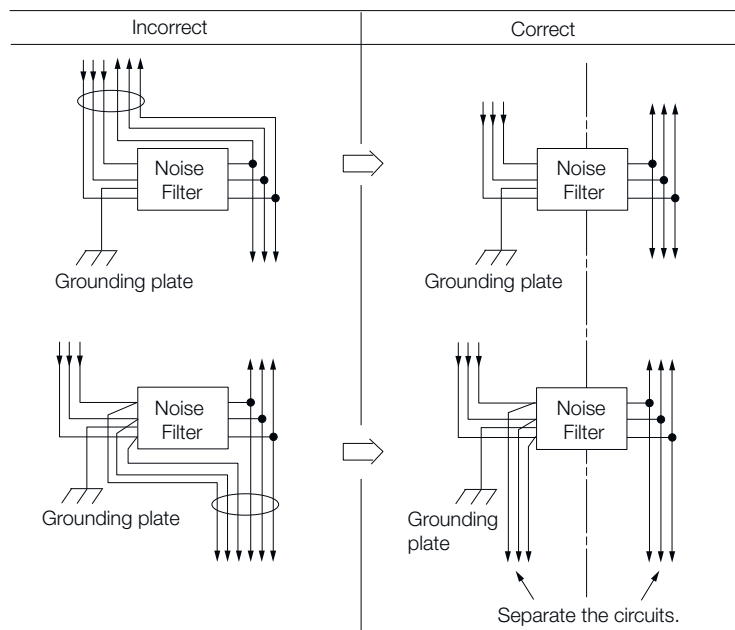


Fig. 43: Noise Filter Wiring - Separate input lines from output lines

- Separate the Noise Filter ground wire from the output lines. Do not place the Noise Filter ground wire, output lines, and other signal lines in the same duct or bundle them together.

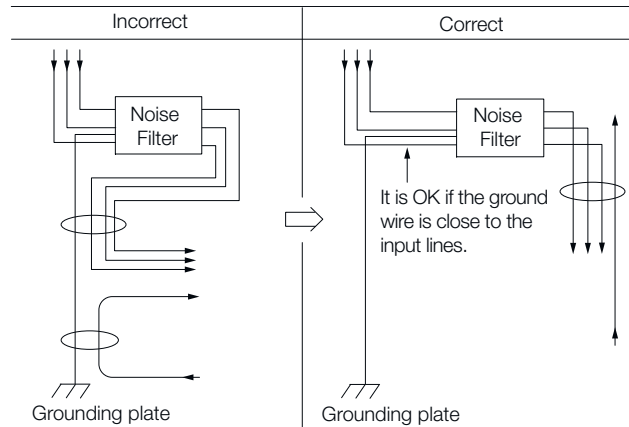


Fig. 44: Noise Filter Wiring - Separate the Noise Filter ground wire from the output lines

- Connect the Noise Filter ground wire directly to the grounding plate. Do not connect the Noise Filter ground wire to other ground wires.

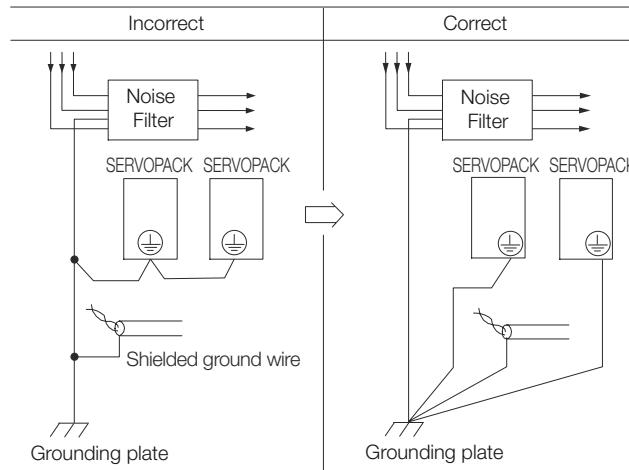


Fig. 45: Noise Filter Wiring - Connect the Noise Filter ground wire directly to the grounding plate

- If a Noise Filter is located inside a control panel, first connect the Noise Filter ground wire and the ground wires from other devices inside the control panel to the grounding plate for the control panel, then ground the plate.

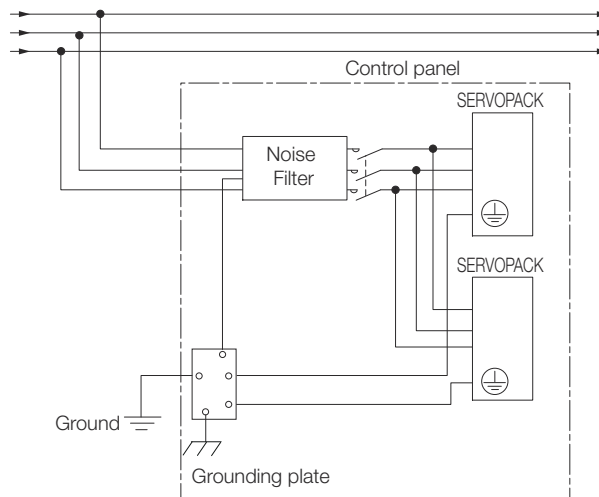


Fig. 46: Grounding Noise Filter

5.2.3 Grounding

Implement grounding measures as described in this section. Implementing suitable grounding measures will also help prevent malfunctions, which can be caused by noise.

Observe the following precautions when wiring the ground cable.

- Ground the SERVOPACK to a resistance of 100 Ω or less.
- Be sure to ground at one point only.
- Ground the Servomotor directly if the Servomotor is insulated from the machine.

Motor Frame Ground or Motor Ground

If you ground the Servomotor through the machine, switching noise current can flow from the main circuit of the SERVOPACK through the stray capacitance of the Servomotor. To prevent this, always connect the FG terminal of the Servomotor Main Circuit Cable connected to the Servomotor to the ground terminal \oplus on the SERVOPACK. Also be sure to ground the ground terminal \oplus . Always connect the shield wire of the Encoder Cable connected to the Servomotor to the connector case (shell).

Ground both the Moving Coil and Magnetic Way of a Linear Servomotor.

Noise on I/O Signal Cables

If noise enters the I/O Signal Cable, connect the shield of the I/O Signal Cable to the connector shell to ground it. If the Servomotor Main Circuit Cable is placed in a metal conduit, ground the conduit and its junction box. For all grounding, ground at one point only.

5.3 Basic Wiring Diagrams

This section provides the basic wiring diagrams. Refer to the reference sections given in the diagrams for details.

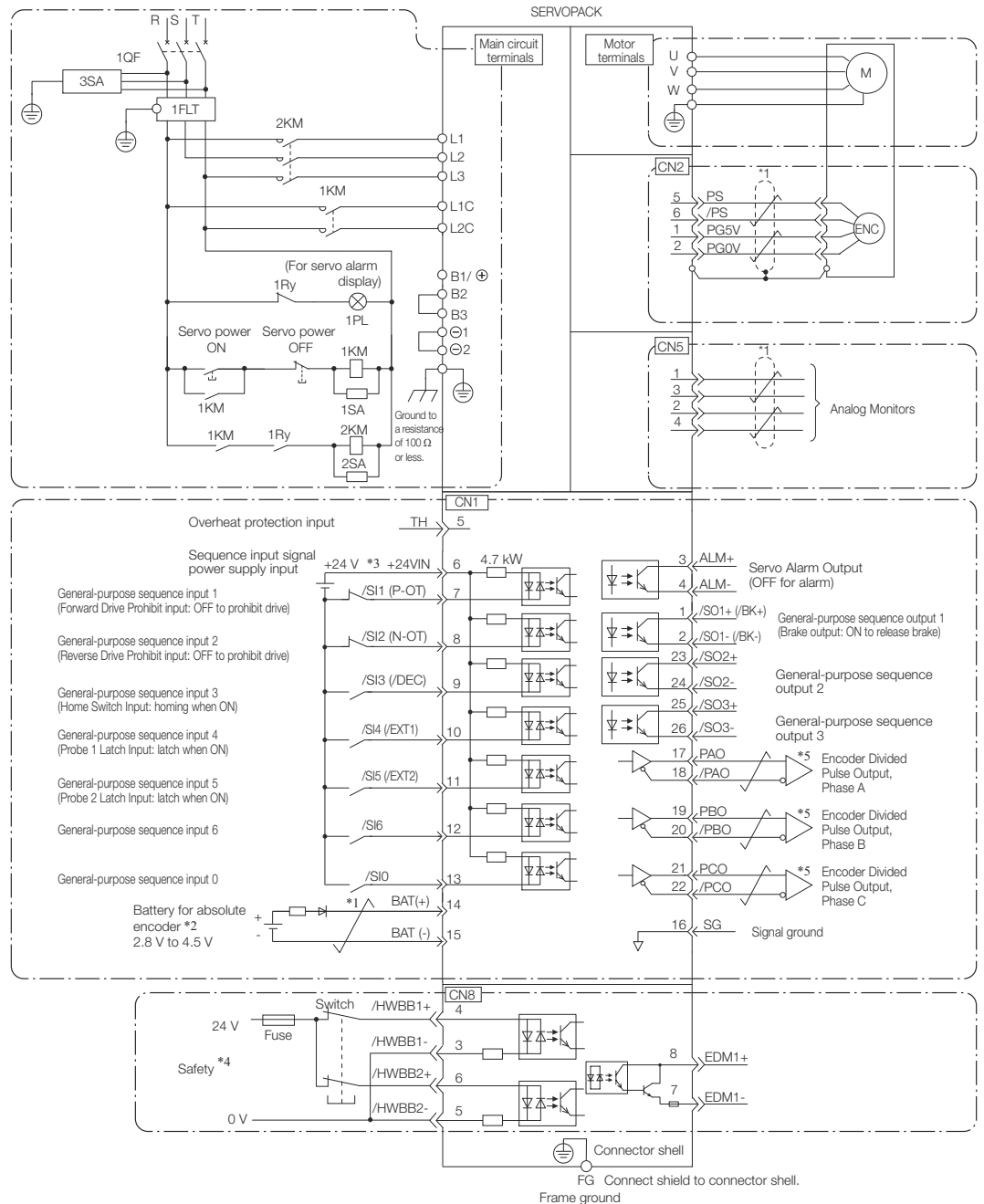


Fig. 47: Basic Wiring Diagram

*1. $\text{---}/\text{---}$ represents twisted-pair wires.

*2. Connect these when using an absolute encoder. If the Encoder Cable with a Battery Case is connected, do not connect a backup battery.

*3. The 24-VDC power supply is not provided by YASKAWA. Use a 24-VDC power supply with double insulation or reinforced insulation.

*4. Refer to the following chapter if you use a safety function device.

➔ [Chap. 12.1 'Safety Functions' ...page 440](#)

If you do not use the safety function, insert the Safety Jumper Connector (provided as an accessory) into CN8 when you use the SERVOPACK.

*5. Always use line receivers to receive the output signals.



- You can use parameters to change the functions allocated to the /SI0, /SI6, P-OT, N-OT, /EXT1, /EXT2, and /DEC input signals and the /SO1, /SO2, and /SO3 output signals. Refer to the following section for details.
→ [Chap. 7.2.1 'I/O Signal Allocations' ...page 189](#)
- If you use a 24-V brake, install a separate power supply for the 24-VDC power supply from other power supplies, such as the one for the I/O signals of the CN1 connector. If the power supply is shared, the I/O signals may malfunction.
- Default settings are given in parentheses.

5.4 Wiring the Power Supply to the SERVOPACK

5.4.1 Overview

Refer to the following manual or catalog for information on cables and peripheral devices.

AC Servo Drives Σ -7 Series (Catalog No.: KAEP S800001 23)

Σ -7-Series Peripheral Device Selection Manual (Manual No.: SIEP S800001 32)

5.4.2 Terminal Symbols and Terminal Names

Use the main circuit connector on the SERVOPACK to wire the main circuit power supply and control circuit power supply to the SERVOPACK.



CAUTION

Wire all connections correctly according to the following table and specified reference information.

There is a risk of SERVOPACK failure or fire if incorrect wiring is performed.

The SERVOPACKs have the following four types of main circuit power supply input specifications.



- For the single-phase, 100 VAC power supply input specification, only a single-phase AC power supply can be connected to the control power supply terminals.
- For the other main circuit power supply input specifications, excluding the single-phase, 100 VAC power supply input specification, a single-phase AC power supply or a DC power supply can be connected to the control power supply terminals.

Three-Phase, 200-VAC Power Supply Input

Terminal Symbols	Terminal Name	Specifications and Reference
L1, L2, L3	Main circuit power supply input terminals for AC power supply input	Three-phase, 200 VAC to 240 VAC, -15% to +10%, 50 Hz/60 Hz
L1C, L2C	Control power supply terminals	AC power supply Single-phase, 200 VAC to 240 VAC, -15% to +10%, 50 Hz/60 Hz

Terminal Symbols	Terminal Name	Specifications and Reference
		DC power supply L1C: 270 VDC to 324 VDC, -15% to +10%, L2C: 0 VDC or L2C: 270 VDC to 324 VDC, -15% to +10%, L1C: 0 VDC
B1/⊕, B2, B3	Regenerative Resistor terminals	<p>→ Chap. 5.4.6 'Wiring Regenerative Resistors' ...page 102</p> <ul style="list-style-type: none"> For SGD7S-R70A, -R90A, -1R6A, and -2R8A If the regenerative capacity is insufficient, connect an External Regenerative Resistor between B1/⊕ and B2. The External Regenerative Resistor is not included. Obtain it separately. For SGD7S-3R8A, -5R5A, -7R6A, -120A, -180A, -200A, and -330A If the internal regenerative resistor is insufficient, remove the lead or short bar between B2 and B3 and connect an External Regenerative Resistor between B1/⊕ and B2. The External Regenerative Resistor is not included. Obtain it separately. For SGD7S-470A, -550A, -590A, and -780A Connect a Regenerative Resistor Unit between B1/⊕ and B2. Obtain a Regenerative Resistor Unit separately. These models do not have a B3 terminal.
⊖1, ⊖2	DC Reactor terminals for power supply harmonic suppression	<p>→ Chap. 5.4.7 'Wiring Reactors for Harmonic Suppression' ...page 104</p> <p>These terminals are used to connect a DC Reactor for power supply harmonic suppression or power factor improvement.</p>
⊖	-	None. (Do not connect anything to this terminal.)

Single-Phase, 200-VAC Power Supply Input

Terminal Symbols	Terminal Name	Specifications and Reference
L1, L2	Main circuit power supply input terminals for AC power supply input	Single-phase, 200 VAC to 240 VAC, -15% to +10%, 50 Hz/60 Hz
L1C, L2C	Control power supply terminals	AC power supply Single-phase, 200 VAC to 240 VAC, -15% to +10%, 50 Hz/60 Hz

Terminal Symbols	Terminal Name	Specifications and Reference
		DC power supply L1C: 270 VDC to 324 VDC, -15% to +10%, L2C: 0 VDC or L2C: 270 VDC to 324 VDC, -15% to +10%, L1C: 0 VDC
B1/⊕, B2, B3	Regenerative Resistor terminals	<p>→ Chap. 5.4.6 'Wiring Regenerative Resistors' ...page 102</p> <ul style="list-style-type: none"> For SGD7S-R70A, -R90A, -1R6A, and -2R8A If the regenerative capacity is insufficient, connect an External Regenerative Resistor between B1/⊕ and B2. The External Regenerative Resistor is not included. Obtain it separately. For SGD7S-5R5A, and -120A□0A008 If the internal regenerative resistor is insufficient, remove the lead or short bar between B2 and B3 and connect an External Regenerative Resistor between B1/⊕ and B2. The External Regenerative Resistor is not included. Obtain it separately.
⊖1, ⊖2	DC Reactor terminals for power supply harmonic suppression	<p>→ Chap. 5.4.7 'Wiring Reactors for Harmonic Suppression' ...page 104</p> <p>These terminals are used to connect a DC Reactor for power supply harmonic suppression or power factor improvement.</p>
⊖	-	None. (Do not connect anything to this terminal.)

You can use a single-phase, 200-V power supply input with the following models.

- SGD7S-R70A, -R90A, -1R6A, -2R8A, -5R5A

If you use a single-phase, 200-VAC power supply input for the SERVOPACK's main circuit power supply, set parameter Pn00B to n.□1□□ (Use a three-phase power supply input as a single-phase power supply input). Refer to the following section for details.

→ [Chap. 6.3.3 'Single-phase AC Power Supply Input/Three-phase AC Power Supply Input Setting' ...page 139](#)



You do not need to change the setting of Pn00B to n.□1□□ (Use a three-phase power supply input as a single-phase power supply input) for a SERVOPACK with a single-phase 200-VAC power supply input (model numbers: SGD7S-120A□□□008).

DC Power Supply Input

Terminal Symbols	Terminal Name	Specifications and Reference
L1C, L2C	Control power supply terminals	AC power supply Single-phase, 200 VAC to 240 VAC, -15% to +10%, 50 Hz/60 Hz

Terminal Symbols	Terminal Name	Specifications and Reference
		DC power supply L1C: 270 VDC to 324 VDC, -15% to +10%, L2C: 0 VDC or L2C: 270 VDC to 324 VDC, -15% to +10%, L1C: 0 VDC
B1/⊕ ⊖2	Main circuit power supply input terminals for DC power supply input	270 VDC to 324 VDC, -15% to +10% 0 VDC
L1, L2, L3, B2, B3, ⊖1, ⊖	–	None. (Do not connect anything to these terminals.)

If you use a DC power supply input to the SERVOPACK, make sure to set parameter Pn001 to n.□1□□ (DC power supply input supported) before inputting the power supply. Refer to the following section for details.

→ [Chap. 6.3.2 'AC Power Supply Input/DC Power Supply Input Setting' ...page 138](#)

Single-Phase, 100-VAC Power Supply Input

Terminal Symbols	Terminal Name	Specifications and Reference
L1 and L2	Main circuit power supply input terminals for AC power supply input	Single-phase, 100 VAC to 120 VAC, -15% to +10%, 50 Hz/60 Hz
L1C and L2C	Control power supply terminals	Single-phase, 100 VAC to 120 VAC, -15% to +10%, 50 Hz/60 Hz
B1 and B2	Regenerative Resistor terminals	→ Chap. 5.4.6 'Wiring Regenerative Resistors' ...page 102 If the regenerative capacity is insufficient, connect an External Regenerative Resistor between B1/⊕ and B2. Obtain an External Regenerative Resistor separately.

You can use a single-phase, 100-VAC power supply input with the following models.

- SGD7S-R70F, -R90F, -2R1F, -2R8F

5.4.3 Wiring Procedure for Main Circuit Connector

Required Items

Required Item	Remarks
Spring Opener or Flat-blade Screwdriver	<ul style="list-style-type: none"> ■ Spring Opener SERVOPACK accessory (You can also use model 1981045-1 from Tyco Electronics Japan G.K.) ■ Flat-blade screwdriver Commercially available screwdriver with tip width of 3.0 mm to 3.5 mm

1. Remove the main circuit connector and motor connector from the SERVOPACK.

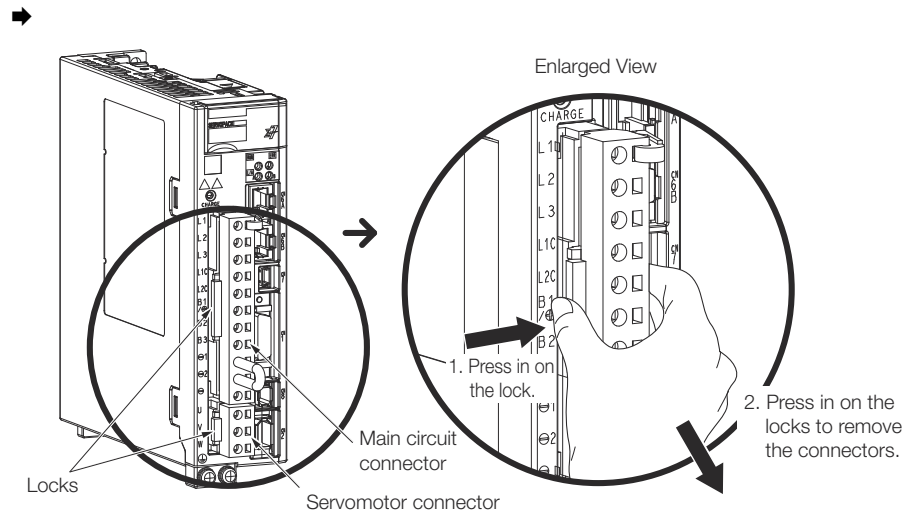


Fig. 48: Removing the main circuit connector and motor connector from the SERVOPACK

2. Remove the sheath from the wire to connect.

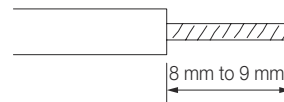
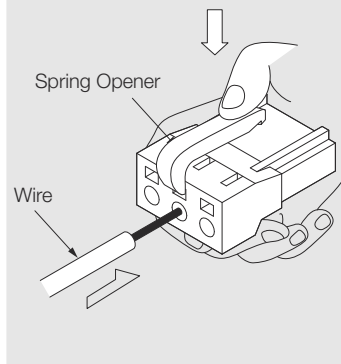


Fig. 49: Removing the sheath from the wire

3. Open the wire insertion hole on the terminal connector with the tool. There are the following two ways to open the insertion hole. Use either method.

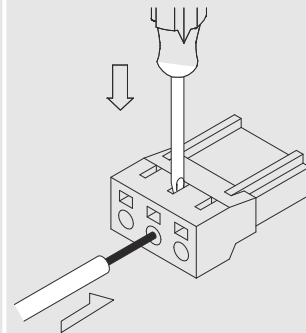
Using a Spring Opener

Open the insertion hole with the Spring Opener as shown in the figure.



Using a Flat-blade Screwdriver

Firmly insert a flat-blade screwdriver into the screwdriver insertion hole to open the wire insertion hole.



4. Insert the conductor into the wire insertion hole. Then, remove the Spring Opener or flatblade screwdriver.
5. Make all other connections in the same way.
6. When you have completed wiring, attach the connectors to the SERVOPACK.

5.4.4 Power ON Sequence

Consider the following points when you design the power ON sequence.

- The ALM (Servo Alarm) signal is output for up to five seconds when the control power supply is turned ON. Take this into consideration when you design the power ON sequence, and turn ON the main circuit power supply to the SERVOPACK when the ALM signal is OFF (alarm cleared).

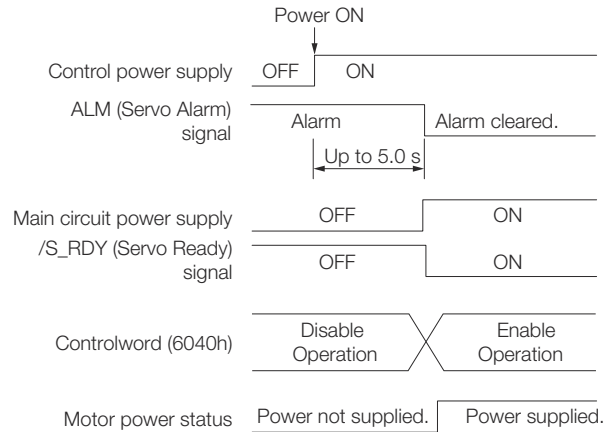


Fig. 50: Power ON Sequence



If the servo ON state cannot be achieved by inputting the Servo ON command (Enable Operation command), the /S_RDY signal is not ON. Check the status of the /S_RDY signal. Refer to the following section for details.

➔ Chap. 7.2.7 'S-RDY (Servo Ready) Signal' ...page 194

- If you use a DC power supply input with any of the following SERVOPACKs, use the power ON sequence shown below: SGD7S-330A, -470A, -550A, -590A, or -780A.

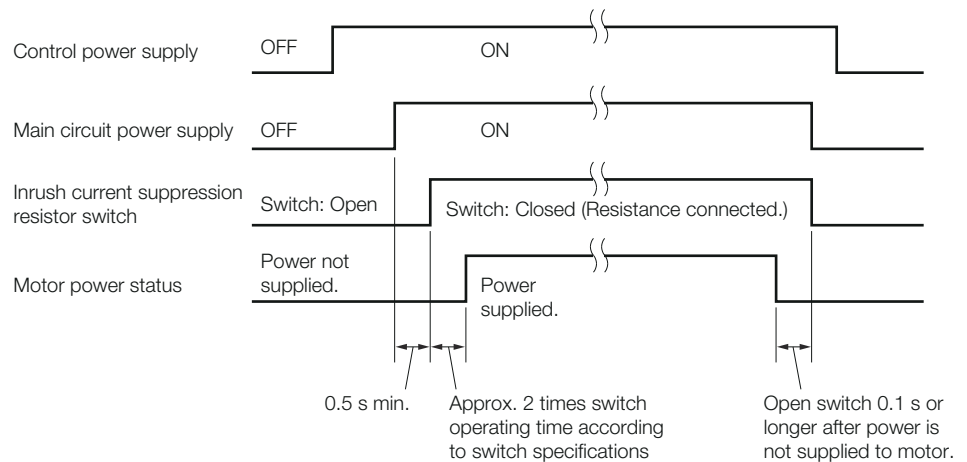


Fig. 51: Power ON Sequence - Using a DC power supply input

- Design the power ON sequence so that main circuit power supply is turned OFF when an ALM (Servo Alarm) signal is output.
- Make sure that the power supply specifications of all parts are suitable for the input power supply.
- Allow at least 1 s after the power supply is turned OFF before you turn it ON again.



Turn ON the control power supply before the main circuit power supply or turn ON the control power supply and the main circuit power supply at the same time.

Turn OFF the main circuit power supply first, and then turn OFF the control power supply.



WARNING

Even after you turn OFF the power supply, a high residual voltage may still remain in the SERVOPACK. To prevent electric shock, do not touch the power supply terminals after you turn OFF the power. When the voltage is discharged, the CHARGE indicator will turn OFF. Make sure the CHARGE indicator is OFF before you start wiring or inspection work.

5.4.5 Power Supply Wiring Diagrams

5.4.5.1 Using Only One SERVOPACK

Wiring Example for Three-Phase, 200-VAC Power Supply Input: SGD7S-R70A, -R90A, -1R6A, -2R8A, -3R8A, -5R5A, -7R6A, -120A, -180A, -200A, and -330A

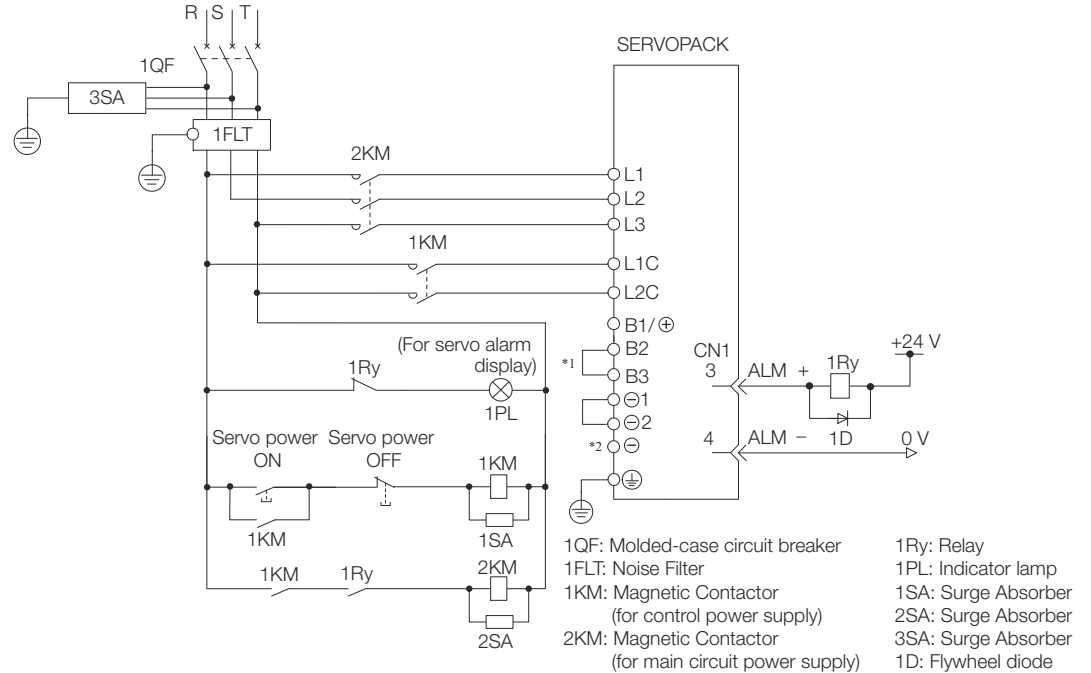


Fig. 52: Wiring Example for Three-Phase, 200-VAC Power Supply Input - 1

- *1 You do not have to connect B2 and B3 for the following models: SGD7S-R70A, SGD7S-R90A, SGD7S-1R6A, and SGD7S-2R8A. Do not connect them.
- *2 A SGD7S-330A SERVOPACK does not have a - terminal.

Wiring the Power Supply to the SERVOPACK > Power Supply Wiring Diagrams

Wiring Example for Three-Phase, 200-VAC Power Supply Input: SGD7S-470A, -550A, -590A, and -780A

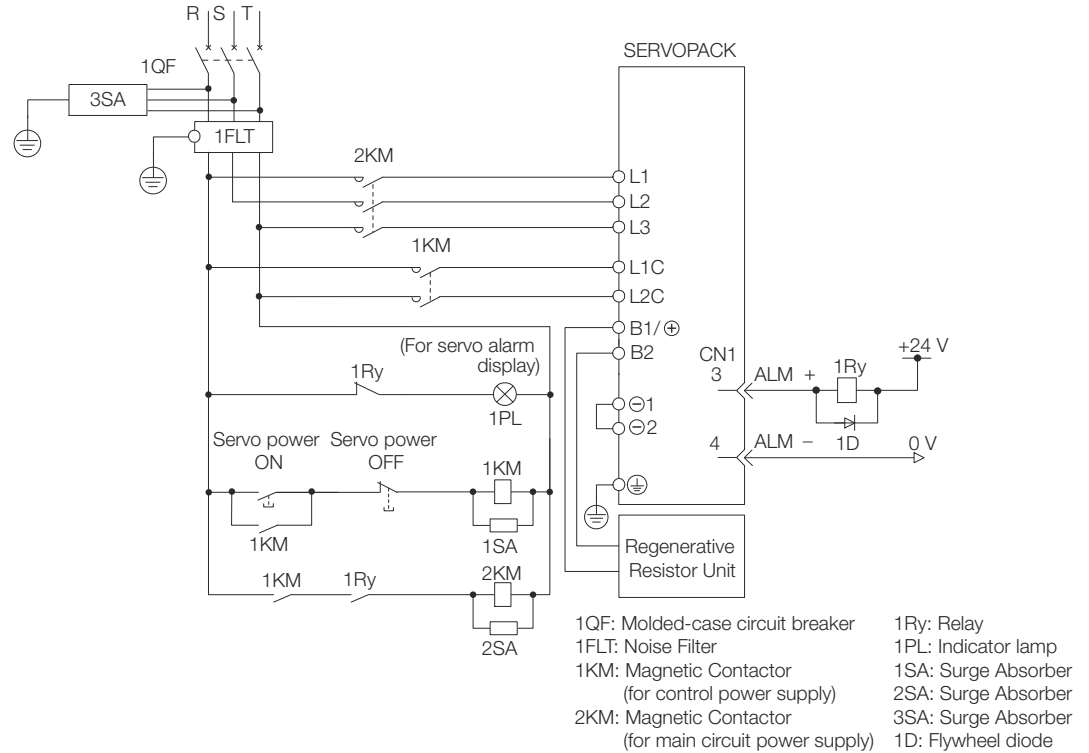


Fig. 53: Wiring Example for Three-Phase, 200-VAC Power Supply Input - 2

Wiring Example for Single-Phase, 200-VAC Power Supply Input

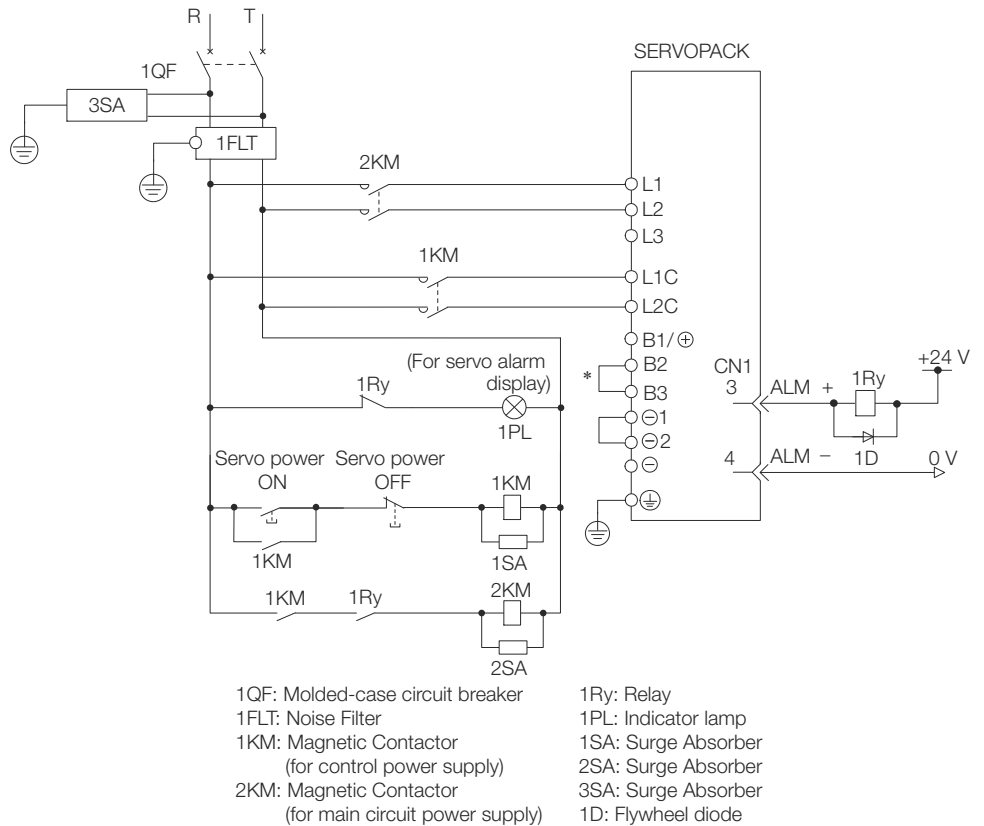


Fig. 54: Wiring Example for Single-Phase, 200-VAC Power Supply Input

* You do not have to connect B2 and B3 for the following models: SGD7S-R70A, -R90A, -1R6A, and -2R8A. Do not connect them.

Wiring Example for DC Power Supply Input:
SGD7S-R70A, -R90A,
-1R6A, -2R8A, -3R8A,
-5R5A, -7R6A, -120A,
-180A, and -200A

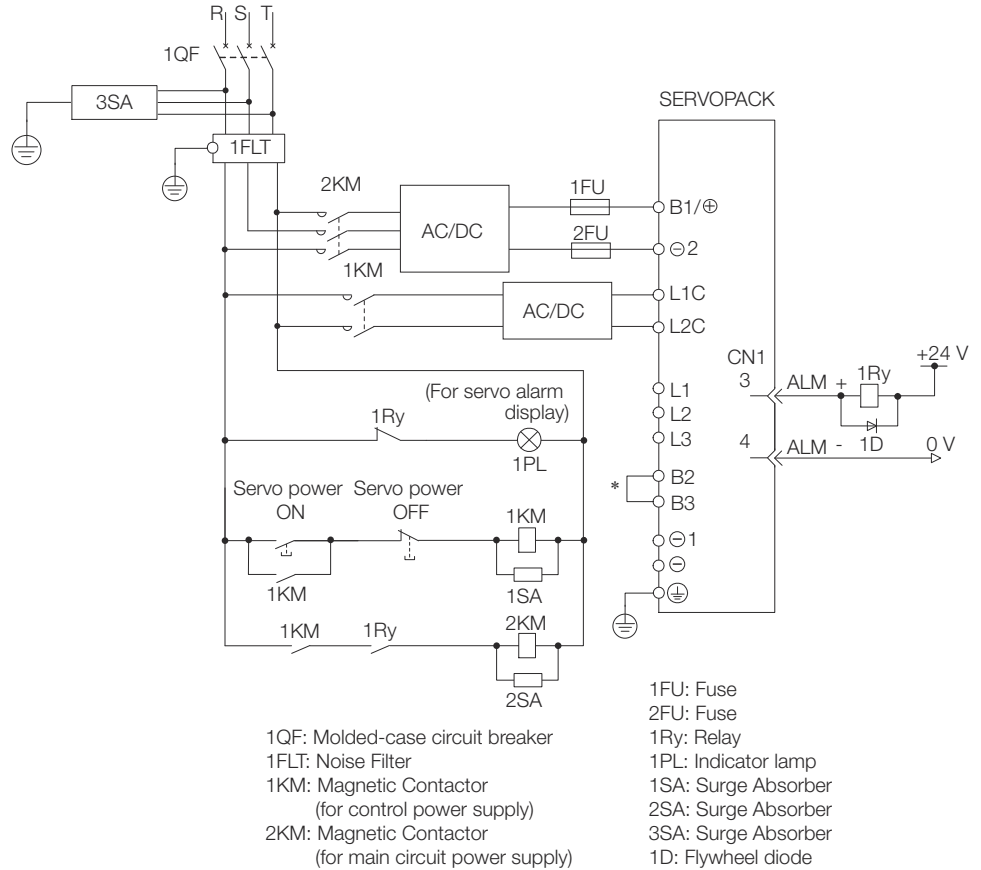
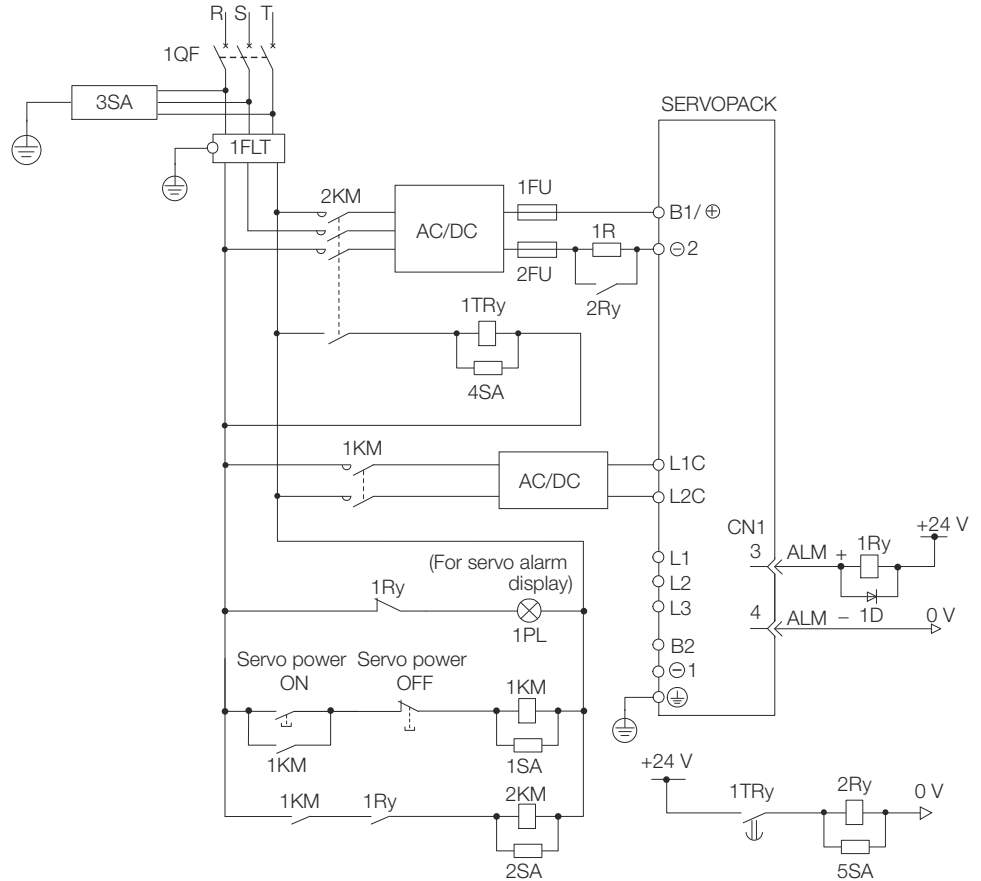


Fig. 55: Wiring Example for DC Power Supply Input - 1

* You do not have to connect B2 and B3 for the following models: SGD7S-R70A, -R90A, -1R6A, and -2R8A. Do not connect them.

Wiring the Power Supply to the SERVOPACK > Power Supply Wiring Diagrams

Wiring Example for DC Power Supply Input:
SGD7S-330A, -470A, -550A, -590A, and -780A



- 1QF: Molded-case circuit breaker
- 1FLT: Noise Filter
- 1KM: Magnetic Contactor
(for control power supply)
- 2KM: Magnetic Contactor
(for main circuit power supply,
auxiliary contact)
- 1FU: Fuse, positive side
- 2FU: Fuse, negative side
- 1Ry: Relay
- 2Ry: Relay (for inrush current
suppression resistor switch)
- 1TRy: Timer relay
- 1PL: Indicator lamp
- 1SA: Surge Absorber
- 2SA: Surge Absorber
- 3SA: Surge Absorber
- 4SA: Surge Absorber
- 5SA: Surge Absorber
- 1D: Flywheel diode
- 1R: External inrush current
suppression resistor

Fig. 56: Wiring Example for DC Power Supply Input - 2

Wiring Example for Single-Phase, 100-VAC Power Supply Input: SGD7S-R70F, -R90F, -2R1F, or -2R8F

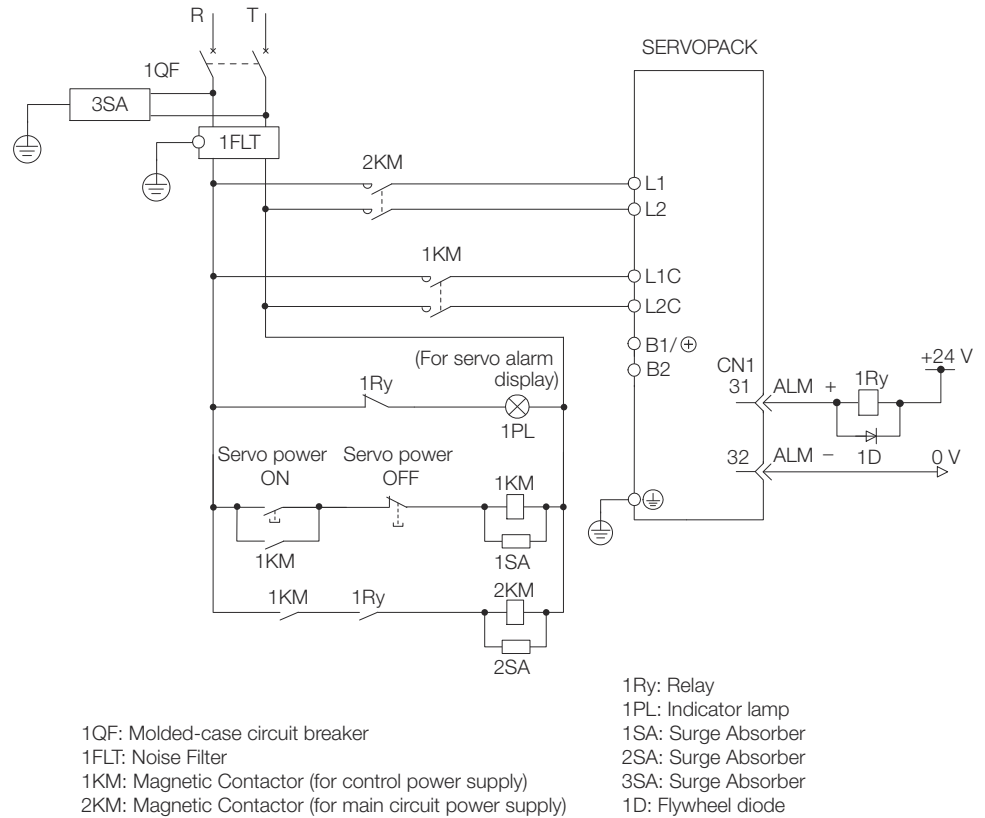


Fig. 57: Wiring Example for Single-Phase, 100-VAC Power Supply Input

5.4.5.2 Using More Than One SERVOPACK

Connect the ALM (Servo Alarm) output for these SERVOPACKs in series to operate the alarm detection relay (1RY).

When a SERVOPACK alarm is activated, the ALM output signal transistor turns OFF.

The following diagram shows the wiring to stop all of the Servomotors when there is an alarm for any one SERVOPACK.

More than one SERVOPACK can share a single Noise Filter. However, always select a Noise Filter that has a large enough capacity to handle the total power supply capacity of all the SERVOPACKs. Be sure to consider the load conditions.

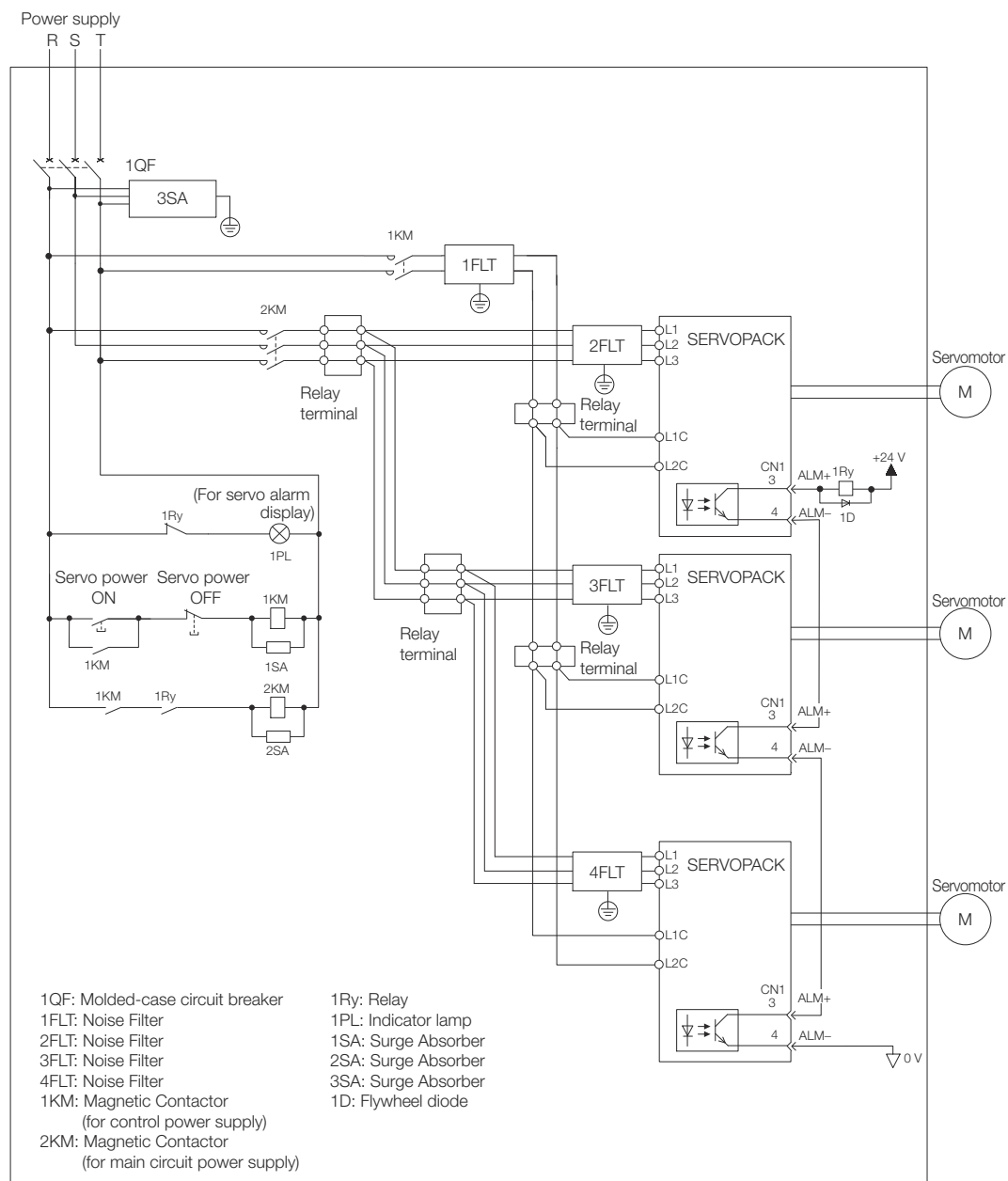


Fig. 58: Stopping all of the Servomotors when there is an alarm for any one SERVOPACK

Refer to the following document for details on international standards.

Σ-7-Series Σ-7S and Σ-7W SERVOPACK Safety Precautions (TOMP C710828 00)

5.4.6 Wiring Regenerative Resistors

This section describes how to connect External Regenerative Resistors.

Refer to the following manual to select the capacity of a Regenerative Resistor.

Σ-7-Series Peripheral Device Selection Manual (Manual No.: SIEP S800001 32)



WARNING

Be sure to wire Regenerative Resistors correctly. Do not connect B1/⊕ and B2.

Doing so may result in fire or damage to the Regenerative Resistor or SERVOPACK.

SERVOPACK Models
SGD7S-R70A, -R90A,
-1R6A, -2R8A, -R70F,
-R90F, -2R1F, and -2R8F

1. → Connect the External Regenerative Resistor between the B1/⊕ and B2 terminals on the SERVOPACK.

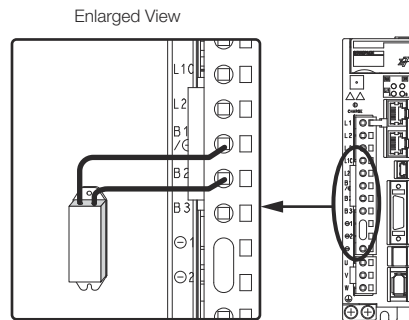


Fig. 59: Connecting the External Regenerative Resistor between the B1/⊕ and B2 terminals on the SERVOPACK

2. → Set Pn600 (Regenerative Resistor Capacity) and Pn603 (Regenerative Resistance). Refer to the following section for details on the settings.

→ [Chap. 6.18 'Setting the Regenerative Resistor Capacity' ...page 187](#)

SERVOPACK Models
SGD7S-3R8A, -5R5A,
-7R6A, -120A, -180A,
-200A, and -330A

1. → Remove the lead from between the B2 and B3 terminals on the SERVOPACK.

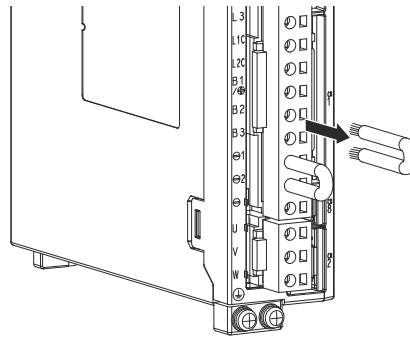


Fig. 60: Removing the lead from between the B2 and B3 terminals on the SERVOPACK

2. → Connect the External Regenerative Resistor between the B1/⊕ and B2 terminals.

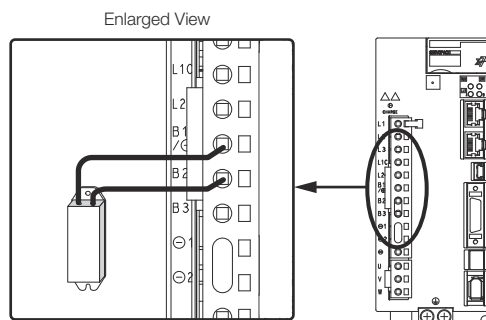


Fig. 61: Connecting the External Regenerative Resistor between the B1/⊕ and B2 terminals

3. → Set Pn600 (Regenerative Resistor Capacity) and Pn603 (Regenerative Resistance). Refer to the following section for details on the settings.

→ [Chap. 6.18 'Setting the Regenerative Resistor Capacity' ...page 187](#)

SERVOPACK Models
SGD7S-470A, -550A,
-590A, and -780A

1. → Connect the R1 and R2 terminals on the Regenerative Resistor Unit to the B1/⊕ and B2 terminals on the SERVOPACK.

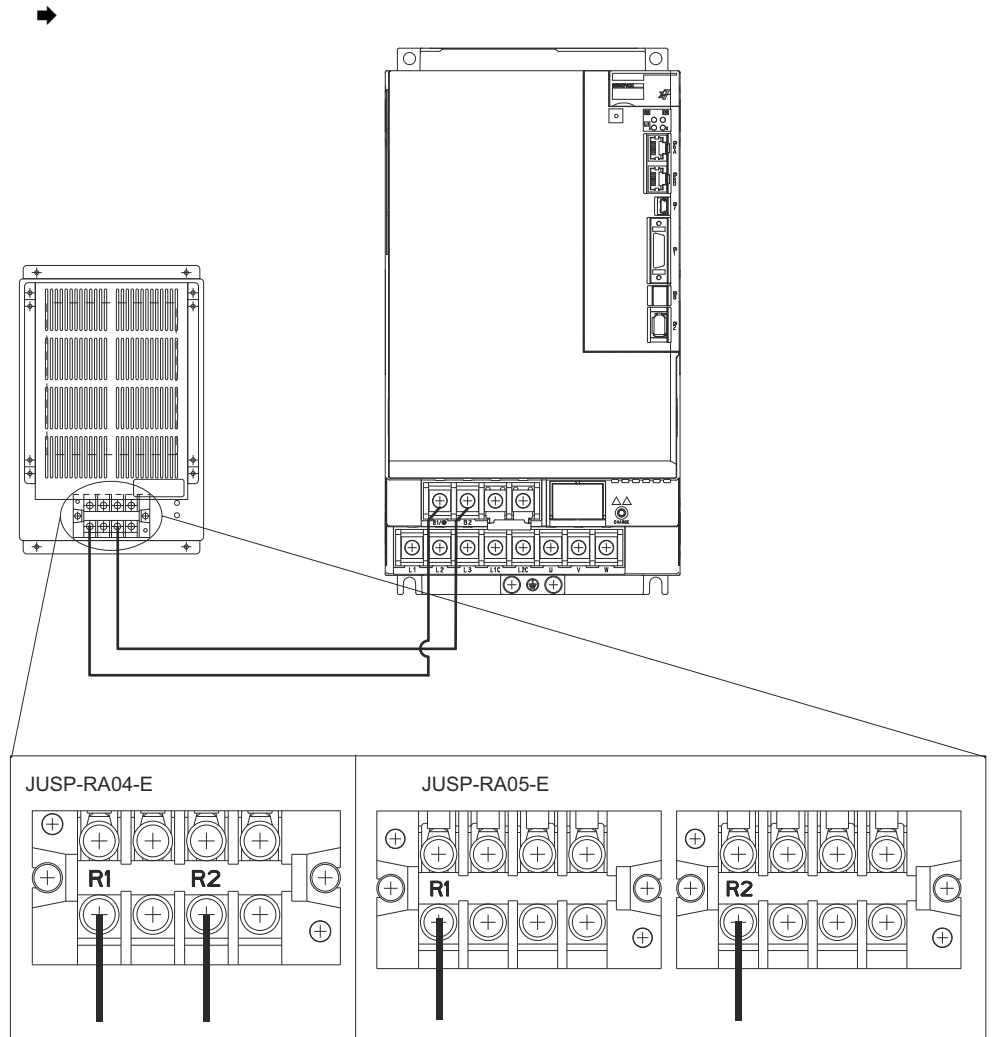


Fig. 62: Connecting the R1 and R2 terminals on the Regenerative Resistor Unit to the B1/⊕ and B2 terminals on the SERVOPACK

2. → Set Pn600 (Regenerative Resistor Capacity) and Pn603 (Regenerative Resistance) as required.
 - When using the Yaskawa-recommended Regenerative Resistor Unit, use the default settings for Pn600 and Pn603.
 - If you use any other external regenerative resistor, set Pn600 and Pn603 according to the specifications of the regenerative resistor.

Refer to the following section for details on the settings.

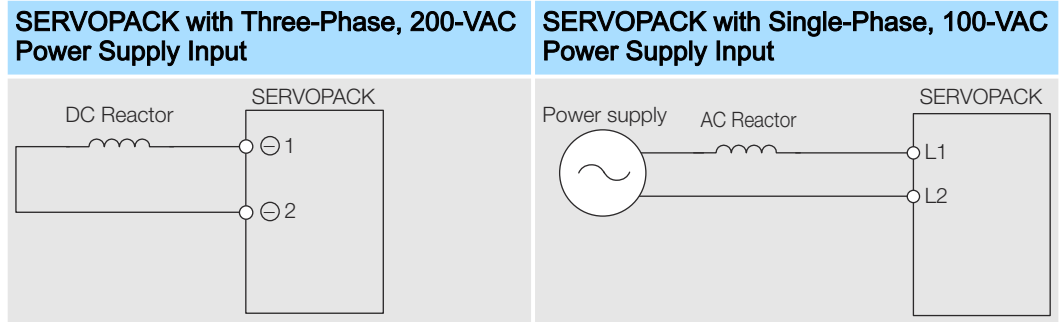
→ [Chap. 6.18 'Setting the Regenerative Resistor Capacity' ...page 187](#)

5.4.7 Wiring Reactors for Harmonic Suppression

You can connect a reactor for harmonic suppression to the SERVOPACK when power supply harmonic suppression is required. Refer to the following manual for details on reactors for harmonic suppression.

📖 [Σ-7-Series Peripheral Device Selection Manual \(Manual No.: SIEP S800001 32\)](#)

Refer to the following figures to connect reactors.



- Connection terminals $\ominus 1$ and $\ominus 2$ for a DC Reactor are connected when the SERVOPACK is shipped. Remove the lead wire and connect a DC Reactor.
- Reactors are optional products. (Purchase them separately.)
- You cannot connect a DC Reactor to a SERVOPACK with a single-phase, 100-VAC power supply input.

5.5 Wiring Servomotors

5.5.1 Terminal Symbols and Terminal Names

The SERVOPACK terminals or connectors that are required to connect the SERVOPACK to a Servomotor are given below.

Terminal/Connector Symbols	Terminal/Connector Name	Remarks
U, V, and W	Servomotor terminals	Refer to the following section for the wiring procedure. → Chap. 5.4.3 'Wiring Procedure for Main Circuit Connector' ...page 94
\oplus	Ground terminal	—
CN2	Encoder connector	—

5.5.2 Pin Arrangement of Encoder Connector (CN2)

- When Using a Rotary Servomotor

Pin No.	Signal	Function
1	PG5V	Encoder power supply +5 V
2	PG0V	Encoder power supply 0 V
3	BAT (+)*	Battery for absolute encoder (+)
4	BAT (-)*	Battery for absolute encoder (-)
5	PS	Serial data (+)
6	/PS	Serial data (-)
Shell	Shield	—

* No wiring is required for an incremental encoder or a batteryless absolute encoder.

- When Using a Direct Drive Servomotor

Pin No.	Signal	Function
1	PG5V	Encoder power supply +5 V
2	PG0V	Encoder power supply 0 V
3	–	– (Do not use.)
4	–	– (Do not use.)
5	PS	Serial data (+)
6	/PS	Serial data (-)
Shell	Shield	–

■ When Using a Linear Servomotor

Pin No.	Signal	Function
1	PG5V	Linear encoder power supply +5 V
2	PG0V	Linear encoder power supply 0 V
3	-	– (Do not use.)
4	-	– (Do not use.)
5	PS	Serial data (+)
6	/PS	Serial data (-)
Shell	Shield	–

5.5.3 Wiring the SERVOPACK to the Encoder

5.5.3.1 When Using an Absolute Encoder

If you use an absolute encoder, use an Encoder Cable with a JUSP-BA01-E Battery Case or install a battery on the host controller.

Refer to the following section for the battery replacement procedure.

→ [Chap. 16.2.4 'Replacing the Battery' ...page 547](#)

Wiring Example When Installing a Battery on the Host Controller

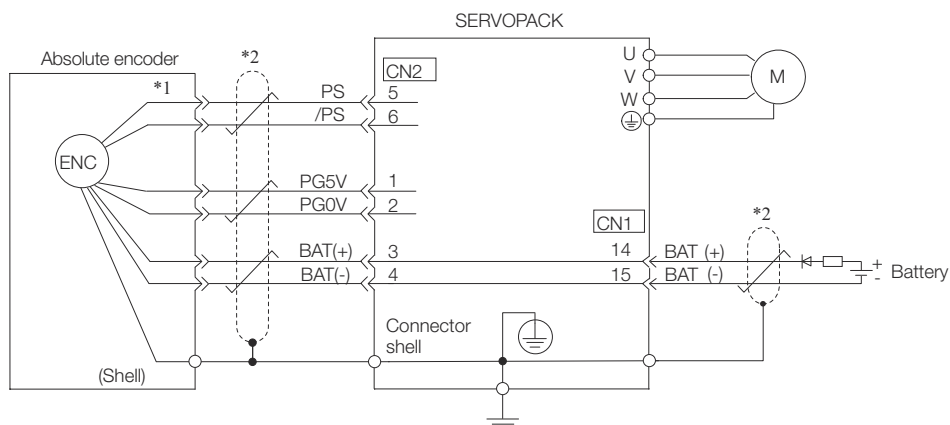


Fig. 63: Wiring Example When Installing a Battery on the Host Controller

- *1 The absolute encoder pin numbers for wiring the connector depend on the Servomotor that you use.
- *2 represents a shielded twisted-pair cable.

Wiring Example When Using an Encoder Cable with a Battery Case

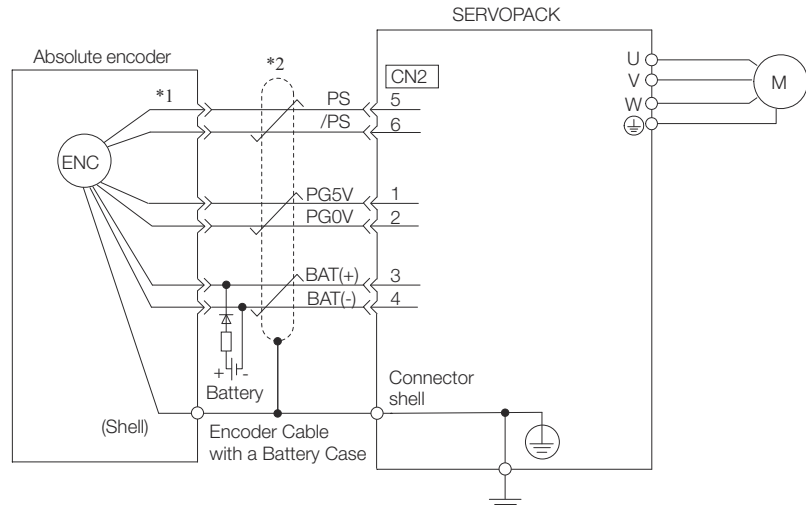




Fig. 64: Wiring Example When Using an Encoder Cable with a Battery Case

- *1 The absolute encoder pin numbers for wiring the connector depend on the Servomotor that you use.
- *2  represents a shielded twisted-pair cable.



- When Installing a Battery on the Encoder Cable
Use the Encoder Cable with a Battery Case that is specified by Yaskawa. Refer to the following manual for details.
 Σ -7-Series AC Servo Drive Peripheral Device Selection Manual (Manual No.: SIEP S800001 32)
- When Installing a Battery on the Host Controller
Insert a diode near the battery to prevent reverse current flow.

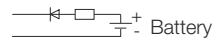


Fig. 65: Inserting a Diode Near the Battery on the Host Controller

Required Component Specifications

- Schottky Diode
 - Reverse Voltage: $V_r \geq 40 \text{ V}$
 - Forward Voltage: $V_f \leq 0.37 \text{ V}$
 - Reverse current: $I_r \leq 5 \mu\text{A}$
 - Junction temperature: $T_j \geq 125 \text{ }^\circ\text{C}$
- Resistor
 - Resistance: 22Ω
 - Tolerance: $\pm 5\%$ max.
 - Rated power: 0.25 W min.

5.5.3.2 When Using an Incremental Encoder or Batteryless Absolute Encoder

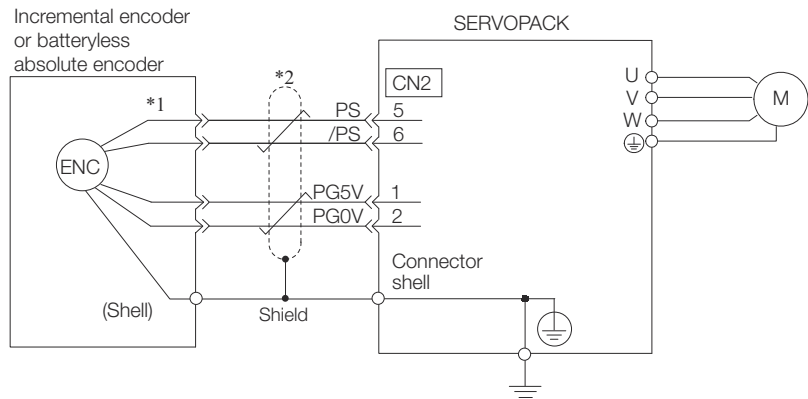


Fig. 66: Wiring Example When Using an Incremental Encoder

- *1 The encoder pin numbers for wiring the connector depend on the Servomotor that you use.
- *2 represents a shielded twisted-pair cable.

5.5.3.3 When Using an Absolute Linear Encoder

The wiring depends on the manufacturer of the linear encoder.

Connections to Linear Encoder from Dr. JOHANNES HEIDENHAIN GmbH

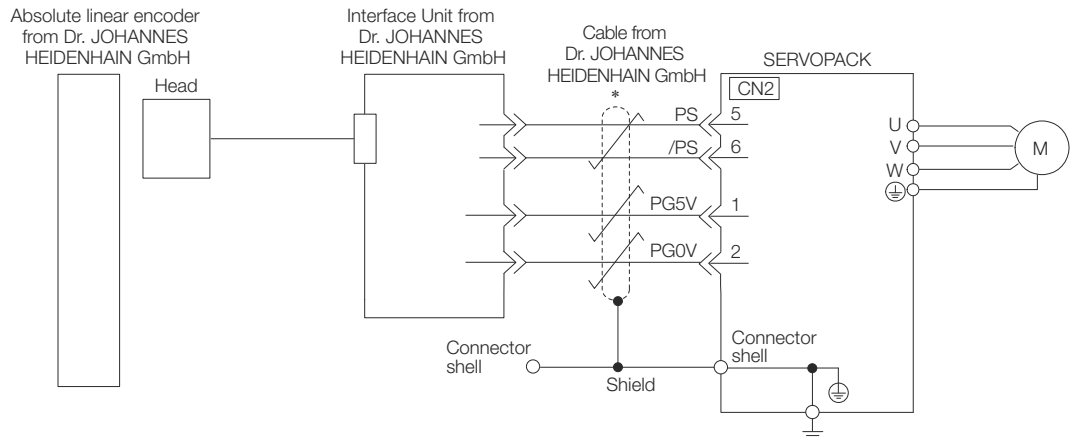


Fig. 67: Connections to Linear Encoder from Dr. JOHANNES HEIDENHAIN

- * represents a shielded twisted-pair cable.

Connections to Linear Encoder from Mitutoyo Corporation

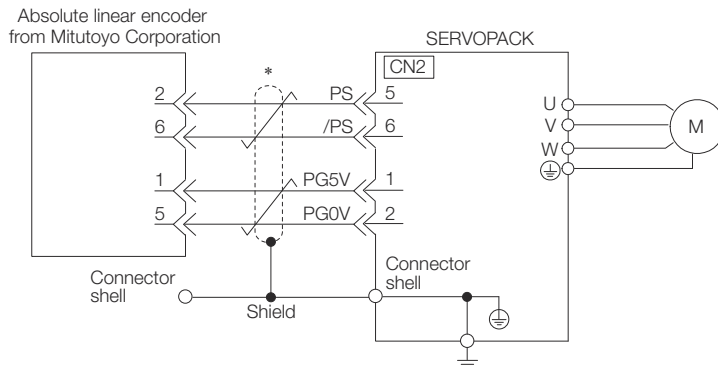


Fig. 68: Absolute Linear Encoder from Mitutoyo Corporation

- * represents a shielded twisted-pair cable.

Connections to Absolute Linear Encoder from Renishaw PLC

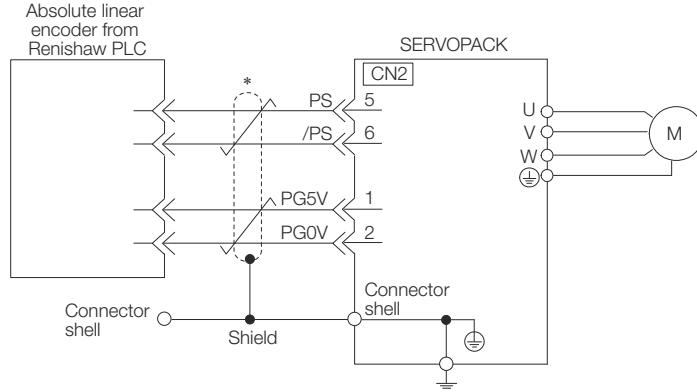


Fig. 69: Absolute Linear Encoder from Renishaw PLC

* represents a shielded twisted-pair cable.

Connections to Absolute Linear Encoder from Magnescale Co., Ltd.

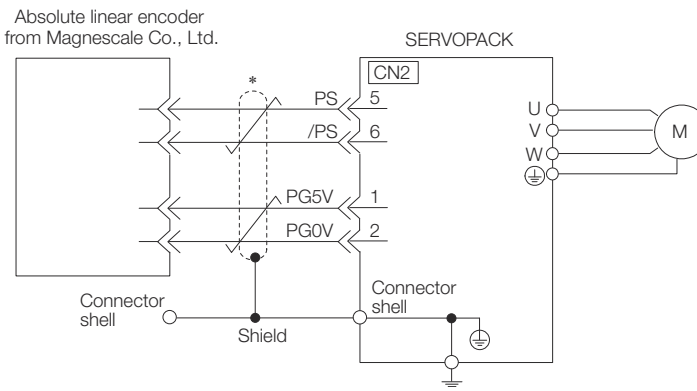


Fig. 70: Absolute Linear Encoder from Magnescale Co., Ltd

* represents a shielded twisted-pair cable.

Connections to Absolute Linear Encoder from Fagor Automation S. Coop.

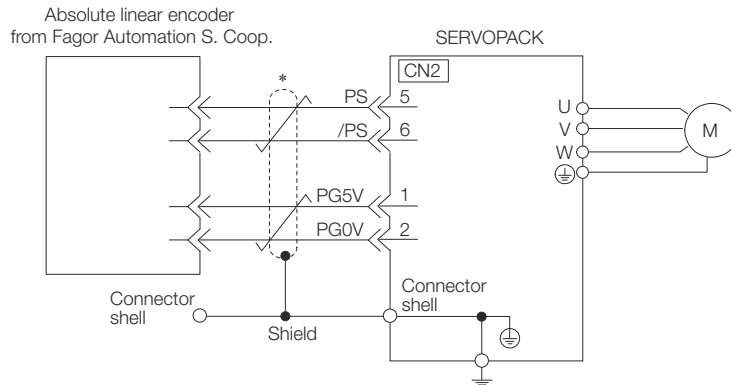


Fig. 71: Connections to Absolute Linear Encoder from Fagor Automation

* represents a shielded twisted-pair cable.

5.5.3.4 When Using an Incremental Linear Encoder

The wiring depends on the manufacturer of the linear encoder.

Connections to Linear Encoder from Dr. JOHANNES HEIDENHAIN GmbH

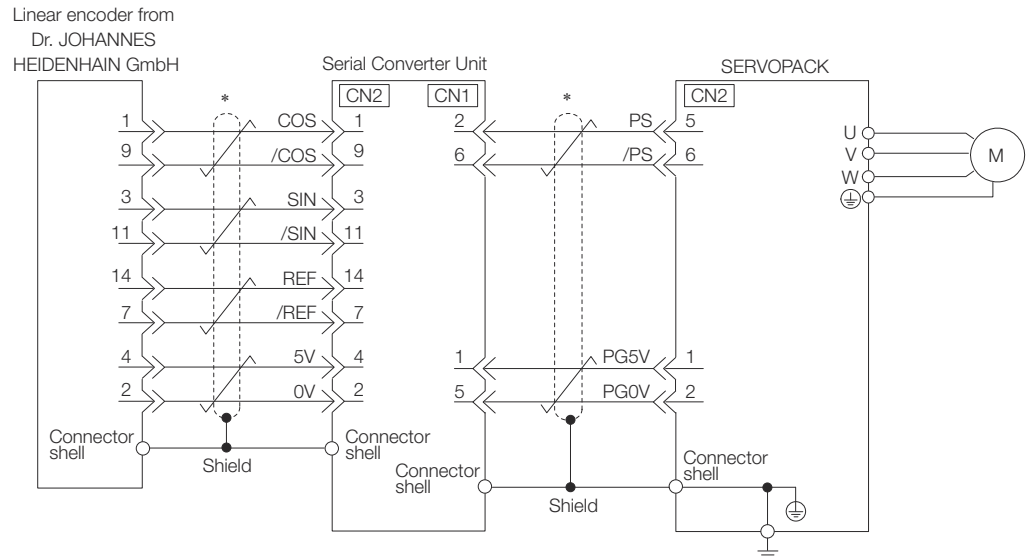


Fig. 72: Incremental Linear Encoder from Dr. JOHANNES HEIDENHAIN GmbH

*  represents a shielded twisted-pair cable.

Connections to Linear Encoder from Renishaw PLC

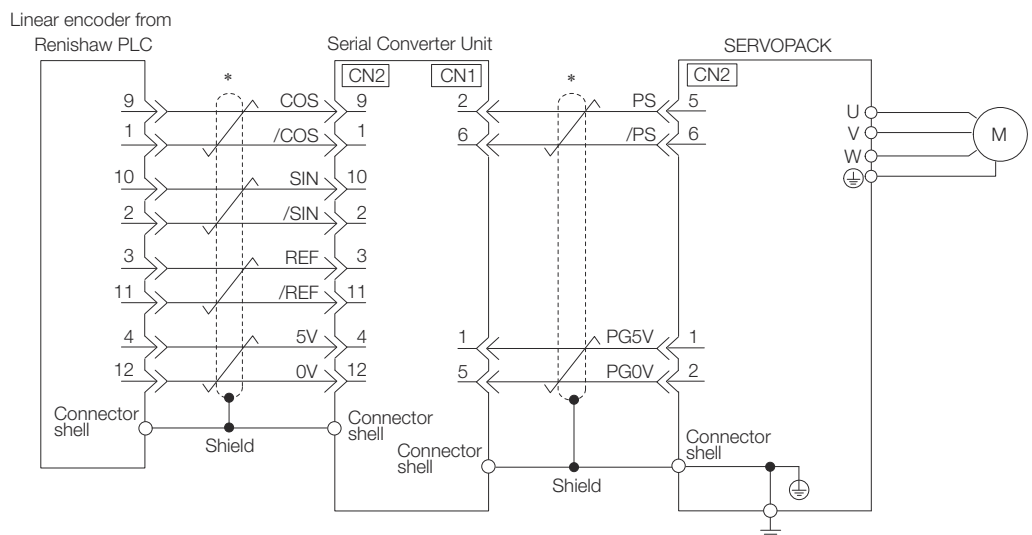


Fig. 73: Incremental Linear Encoder from Renishaw PLC

*  represents a shielded twisted-pair cable.

Connections to Linear Encoder from Magnescale Co., Ltd.

If you use a linear encoder from Magnescale Co., Ltd., the wiring will depend on the model of the linear encoder.

SR75 and SR85

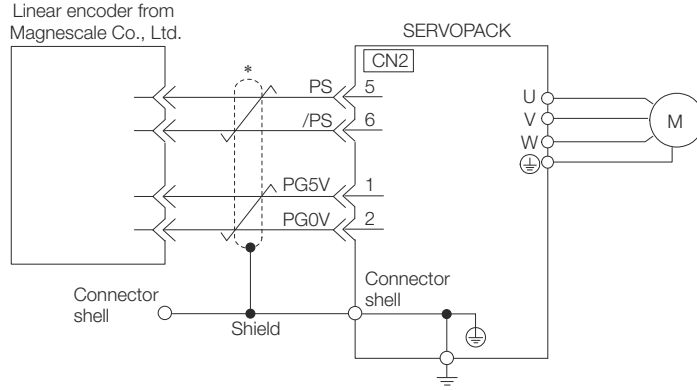


Fig. 74: Incremental Linear Encoder from Magnescale Co., Ltd - SR75 and SR85

* represents a shielded twisted-pair cable.

SL700, SL710, SL720, SL730, and SQ10

- PL101-RY, MQ10-FLA, or MQ10-GLA Interpolator

The following table gives the Linear Encoder and Interpolator combinations.

Linear Encoder Model	Interpolator Model
SL700, SL710, SL720, and SL730	PL101-RY*1
SQ10	MQ10-FLA*2
	MQ10-GLA*2

*1. This is the model of the Head with Interpolator.

*2. This is the model of the Interpolator.

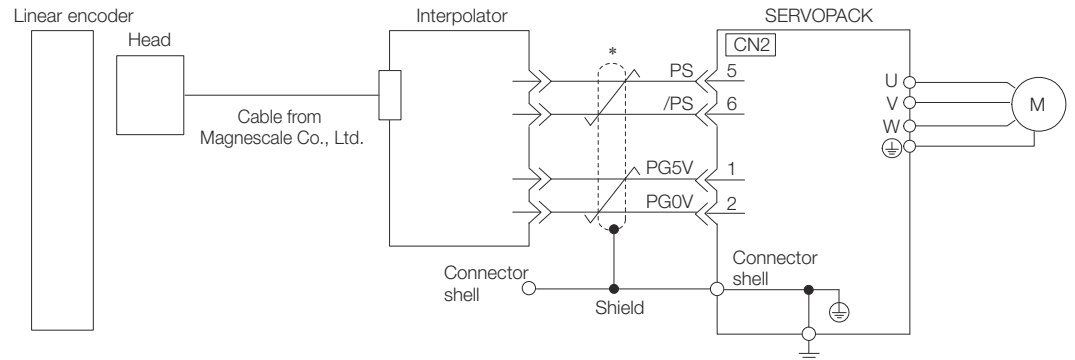


Fig. 75: Incremental Linear Encoder from Magnescale Co., Ltd - SL700, SL710, SL720, SL730, and SQ10

* represents a shielded twisted-pair cable.

SL700, SL710, SL720, and SL730

- MJ620-T13 Interpolator

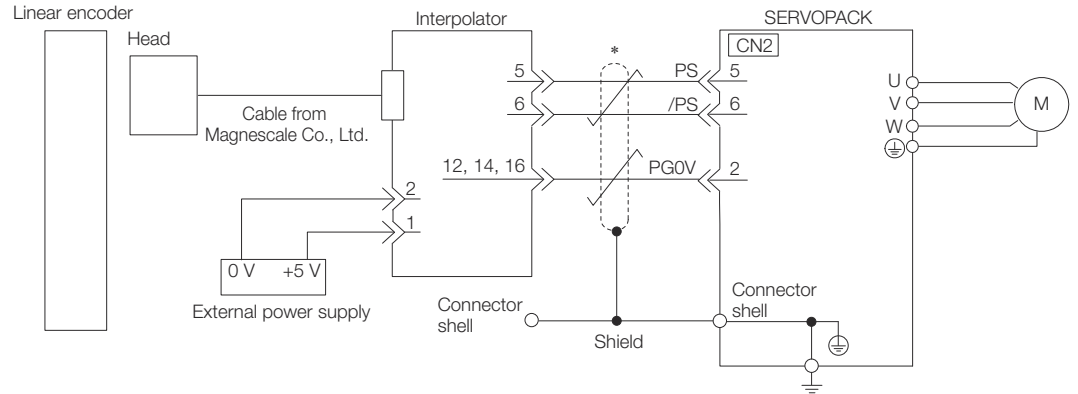


Fig. 76: Incremental Linear Encoder from Magnescale Co., Ltd - SL700, SL710, SL720, and SL730

* represents a shielded twisted-pair cable.

5.5.4 Wiring the SERVOPACK to the Holding Brake



- If you use a Rotary Servomotor, select a Surge Absorber according to the brake current and brake power supply. Refer to the following manual for details.
Σ-7-Series Peripheral Device Selection Manual (Manual No.: SIEP S80001 32)
- After the Surge Absorber is connected, check the brake operation delay time in your application. The Surge Absorber may affect the brake operation delay time. Configure the relay circuit to activate the holding brake for an emergency stop.

Relay Circuit Example

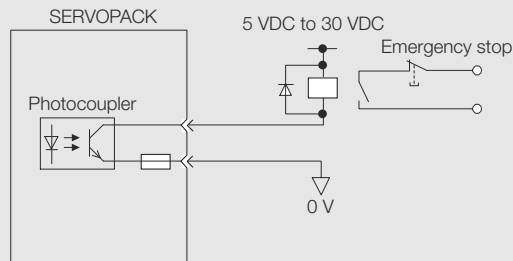


Fig. 77: Relay Circuit Example



- You can change the output signal allocation of the /BK signal. Refer to the following section for details.
[↪ Chap. 6.12.3 '/BK \(Brake\) Signal' ...page 163](#)
- If you use a 24-V brake, install a separate power supply for the 24-VDC power supply from other power supplies, such as the one for the I/O signals of the CN1 connector. If the power supply is shared, the I/O signals may malfunction.

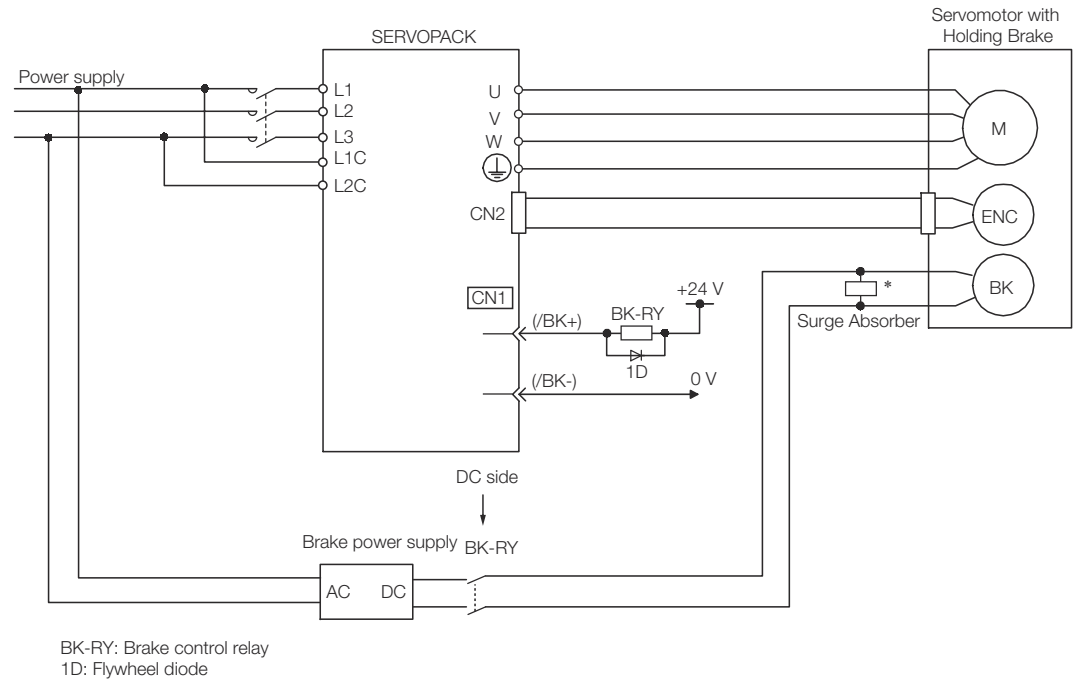


Fig. 78: Wiring example for SERVOPACKs without built-in Servomotor brake control

* Install the Surge Absorber near the brake terminals on the Servomotor.

5.6 Connecting I/O Signals

5.6.1 I/O Signal Connector (CN1) Names and Functions

The following table gives the pin numbers, names, and functions the I/O signal pins for the default settings.

Input Signals

Default settings are given in parentheses.

Signal	Pin No.	Name	Function	Reference
/SI1* (P-OT)	7	General-purpose Sequence Input 1 (Forward Drive Prohibit Input)	You can allocate the input signal to use with a parameter. (Stops Servomotor drive (to prevent overtravel) when the moving part of the machine exceeds the range of movement.)	→ Chap. 6.11.2 'Overtravel Signals' ...page 156
/SI2* (N-OT)	8	General-purpose Sequence Input 2 (Reverse Drive Prohibit Input)		
/SI3* (/DEC)	9	General-purpose Sequence Input 3 (Home Switch Input)	You can allocate the input signal to use with parameters. (Connect the switch that starts homing.)	-
/SI4* (/EXT1)	10	General-purpose Sequence Input 4 (Probe 1 Latch Input)	You can allocate the input signals to use with parameters. (Connect the external signals that latch the current feedback pulse counter.)	-
/SI5* (/EXT2)	11	General-purpose Sequence Input 5 (Probe 2 Latch Input)		
/SI6*	12	General-purpose Sequence Input 6	You can allocate the input signal to use with parameters. (Used for general-purpose input.)	
/SI0*	13	General-purpose Sequence Input 0	You can allocate the input signal to use with a parameter. (Used for general-purpose input.)	-
+24VIN	6	Sequence Input Signal Power Supply Input	Inputs the sequence input signal power supply. Allowable voltage range: 24 VDC ±20% The 24-VDC power supply is not provided by Yaskawa.	-
BAT+	14	Battery for Absolute Encoder (+)	These are the pins to connect the absolute encoder backup battery.	-
BAT-	15	Battery for Absolute Encoder (-)		

Signal	Pin No.	Name	Function	Reference
			Do not connect these pins if you use the Encoder Cable with a Battery Case.	
TH	5	Overheat Protection Input	Inputs the overheat protection signal from a Linear Servomotor or from a sensor attached to the machine.	↪ Chap. 7.15.2 'Connecting the Overheat Protection Input (TH) Signal' ...page 248

* You can change the allocations. Refer to the following section for details.

↪ Chap. 7.2.2 'Input Signal Allocations' ...page 189



If forward drive prohibition or reverse drive prohibition is used, the SERVOPACK is stopped by software controls. If the application does not satisfy the safety requirements, add external safety circuits as required.

Output Signals

Default settings are given in parentheses.

Signal	Pin No.	Name	Function	Reference
ALM+	3	Servo Alarm Output	Turns OFF (opens) when an error is detected.	↪ Chap. 7.2.4 'ALM (Servo Alarm) Signal' ...page 192
ALM-	4			
/SO1+* (/BK+)	1	General-purpose Sequence Output 1 (Brake Output)	You can allocate the output signal to use with a parameter. (Controls the brake. The brake is released when the signal turns ON (closes).)	↪ Chap. 6.12.1 'Holding Brake' ...page 161
/SO1-* (/BK-)	2			
/SO2+*	23	General-purpose Sequence Output 2	Used for general-purpose outputs. Set the parameters to allocate functions.	↪ Chap. 15.13 'Digital Inputs/Outputs' ...page 544
/SO2-*	24			
/SO3+*	25	General-purpose Sequence Output 3		
/SO3-*	26			
PAO	17	Encoder Divided Pulse Output, Phase A	Output the encoder divided pulse output signals with a 90° phase differential.	↪ Chap. 7.9.2 'Connecting an Absolute Encoder' ...page 220
/PAO	18			
PBO	19	Encoder Divided Pulse Output, Phase B		
/PBO	20			

Signal	Pin No.	Name	Function	Reference
PCO	21	Encoder Divided Pulse Output, Phase C	Outputs the origin signal once every encoder rotation.	→ Chap. 7.10.2 'Connecting an Absolute Linear Encoder' ...page 230
/PCO	22			
SG	16	Signal ground	This is the 0-V signal for the control circuits.	-
FG	Shell	Frame ground	Connected to the frame ground if the shield of the I/O Signal Cable is connected to the connector shell.	-

* You can change the allocations. Refer to the following section for details.

→ Chap. 7.2.3 'Output Signal Allocations' ...page 190

5.6.2 I/O Signal Connector (CN1) Pin Arrangement

The following figure gives the pin arrangement of the of the I/O signal connector (CN1) for the default settings.

The top view is from the direction of the arrow without the connector shell attached.

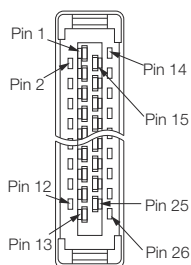


Fig. 79: Top View of I/O Signal Connector (CN1)

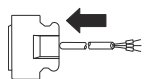


Fig. 80: Side View of I/O Signal Connector (CN1)

No	Signal	Specification	No	Signal	Specification
1	/SO1+ (/BK+)	General-purpose Sequence Output 1	14	BAT+	Battery for Absolute Encoder (+)
2	/SO1- (/BK-)	General-purpose Sequence output 1	15	BAT-	Battery for Absolute Encoder (-)
3	ALM+	Servo Alarm Output	16	SG	Signal Ground
4	ALM-	Servo Alarm Output	17	PAO	Encoder Divided Pulse Output, Phase A
5	TH	Overheat Protection Input	18	/PAO	Encoder Divided Pulse Output, Phase A
6	+24VIN	Sequence Input Signal Power Supply Input	19	PBO	Encoder Divided Pulse Output, Phase B
7	/SI1 (P-OT)	General-purpose Sequence Input 1	20	/PBO	Encoder Divided Pulse Output, Phase B
8	/SI2 (N-OT)	General-purpose Sequence Input 2	21	PCO	Encoder Divided Pulse Output, Phase C
9	/SI3 (/DEC)	General-purpose Sequence Input 3	22	/PCO	Encoder Divided Pulse Output, Phase C

No	Signal	Specification	No	Signal	Specification
10	/SI4 (/EXT1)	General-purpose Sequence Input 4	23	/SO2+	General-purpose Sequence Output 2
11	/SI5 (/EXT2)	General-purpose Sequence Input 5	24	/SO2-	General-purpose Sequence Output 2
12	/SI6	General-purpose Sequence Input 6	25	/SO3+	General-purpose Sequence Output 3
13	/SI0	General-purpose Sequence Input 0	26	/SO3-	General-purpose Sequence Output 3

5.6.3 I/O Signal Wiring Examples

Using a Rotary Servomotor

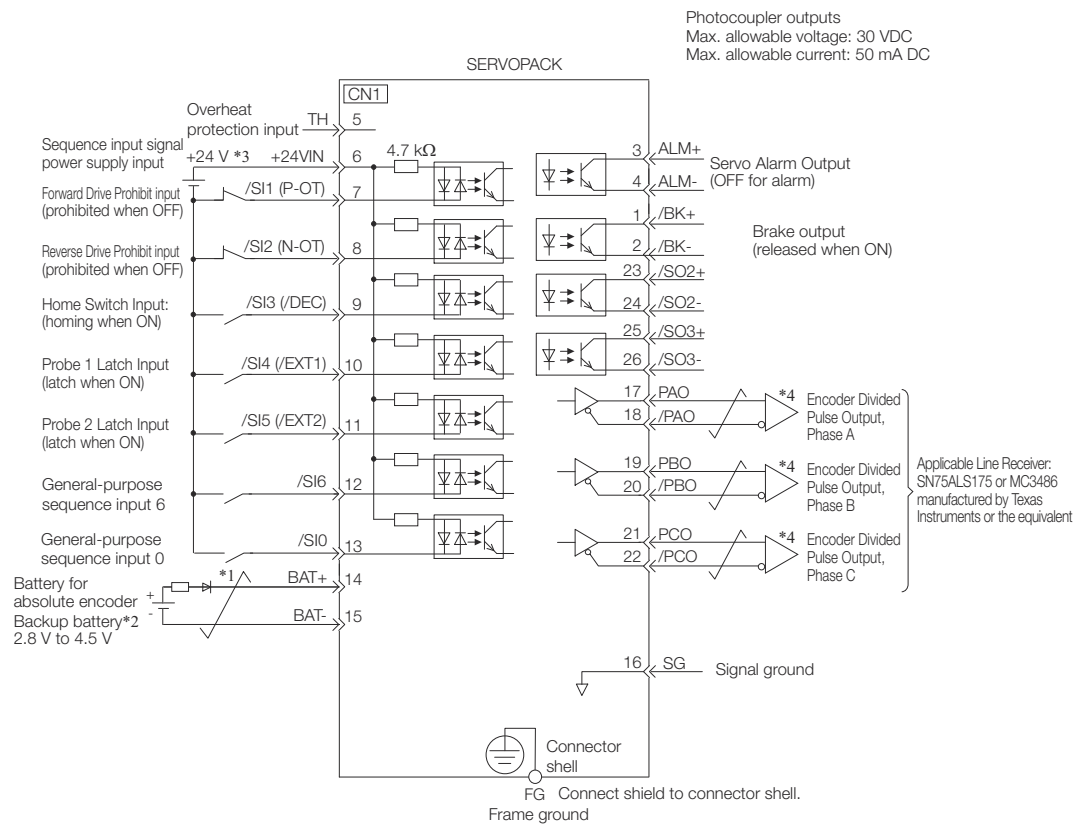


Fig. 81: I/O Signal Wiring Example - Rotary Servomotor

- *1 \neq represents twisted-pair wires.
- *2 Connect these when using an absolute encoder. If the Encoder Cable with a Battery Case is connected, do not connect a backup battery.
- *3 The 24-VDC power supply is not provided by YASKAWA. Use a 24-VDC power supply with double insulation or reinforced insulation.
- *4 Always use line receivers to receive the output signals.



- You can use parameters to change the functions allocated to the /SI0, /SI6, P-OT, N-OT, /EXT1, /EXT2, and /DEC input signals and the /SO1, /SO2, and /SO3 output signals.
 → Chap. 7.2.1 'I/O Signal Allocations' ...page 189

- If you use a 24-V brake, install a separate power supply for the 24-VDC power supply from other power supplies, such as the one for the I/O signals of the CN1 connector. If the power supply is shared, the I/O signals may malfunction.

Using a Linear Servomotor

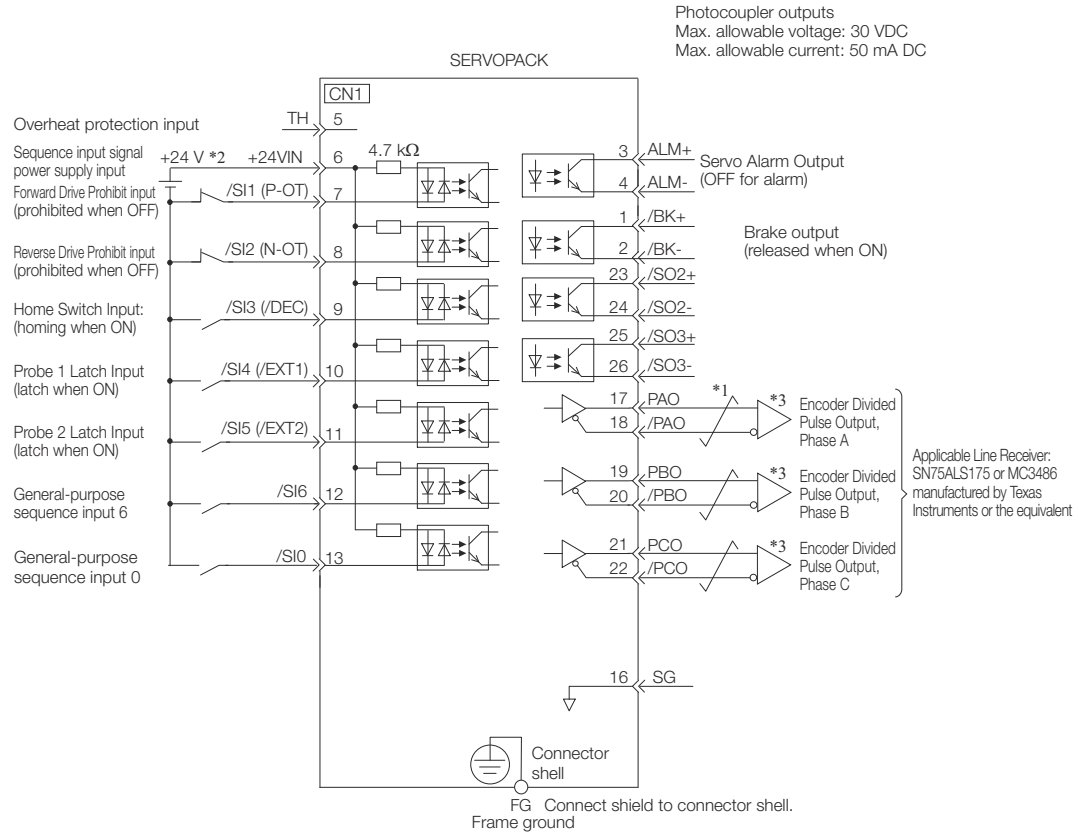


Fig. 82: I/O Signal Wiring Example - Linear Servomotor

- *1 represents twisted-pair wires.
- *2 The 24-VDC power supply is not provided by YASKAWA. Use a 24-VDC power supply with double insulation or reinforced insulation.
- *3 Always use line receivers to receive the output signals.



- You can use parameters to change the functions allocated to the /SI0, /SI6, P-OT, N-OT, /EXT1, /EXT2, and /DEC input signals and the /SO1, /SO2, and /SO3 output signals.
→ Chap. 7.2.1 'I/O Signal Allocations' ...page 189
- If you use a 24-V brake, install a separate power supply for the 24-VDC power supply from other power supplies, such as the one for the I/O signals of the CN1 connector. If the power supply is shared, the I/O signals may malfunction.

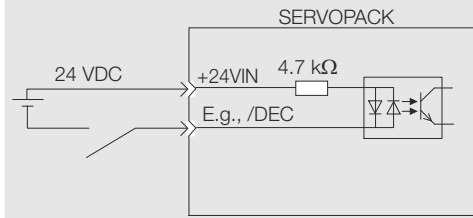
5.6.4 I/O Circuits

Sequence Input Circuits

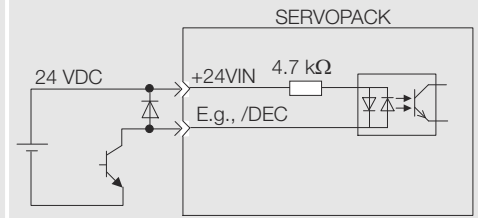
■ Photocoupler Input Circuits

This section describes CN1 connector terminals 6 to 13.

Examples for Relay Circuits



Examples for Open-Collector Circuits



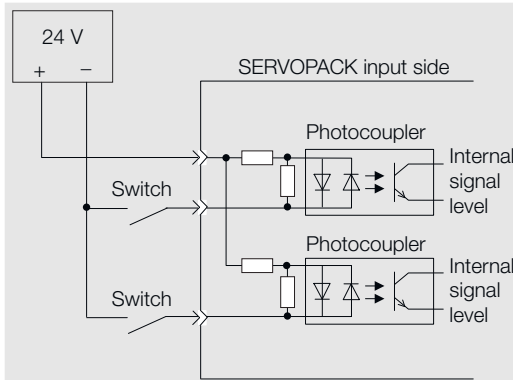
The 24-VDC external power supply capacity must be 50 mA minimum.

The SERVOPACK input circuits use bidirectional photocouplers. Select either a sink circuit or source circuit according to the specifications required by the machine.

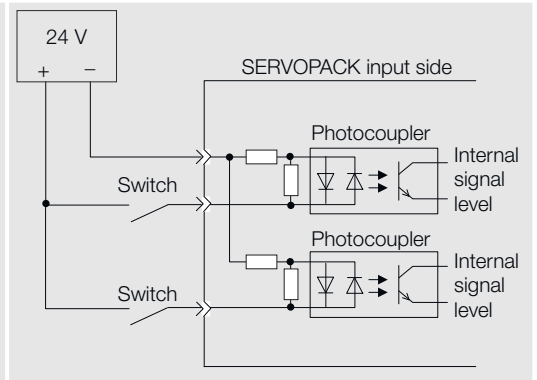


The connection examples in [Chap. 5.6.3 'I/O Signal Wiring Examples' ...page 117](#) are for sink circuit connections.

Sink Circuits



Source Circuits



Input Signal Polarity

Photocoupler	Internal Signal Level
ON	Low level
OFF	High level

Input Signal Polarity

Photocoupler	Internal Signal Level
ON	Low level
OFF	High level

Sequence Output Circuits

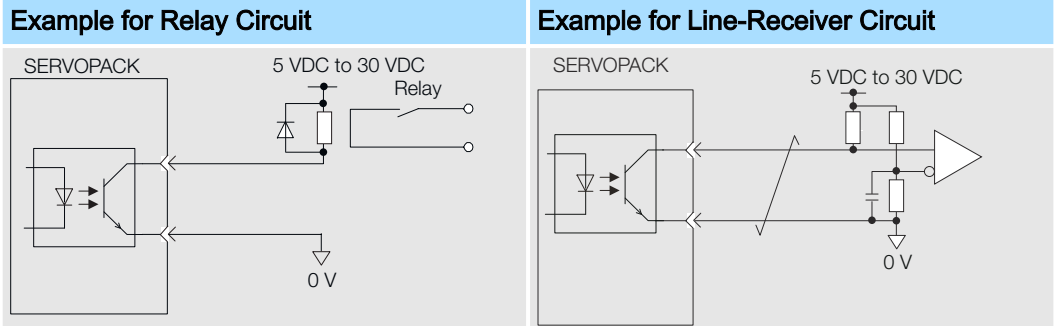


Incorrect wiring or incorrect voltage application to the output circuits may cause short-circuit failures.

If a short-circuit failure occurs as a result of any of these causes, the holding brake will not work. This could damage the machine or cause an accident that may result in death or injury.

■ Photocoupler Output Circuits

Photocoupler output circuits are used for the ALM (Servo Alarm), /S-RDY (Servo Ready), and other sequence output signals. Connect a photocoupler output circuit to a relay or line-receiver circuit.



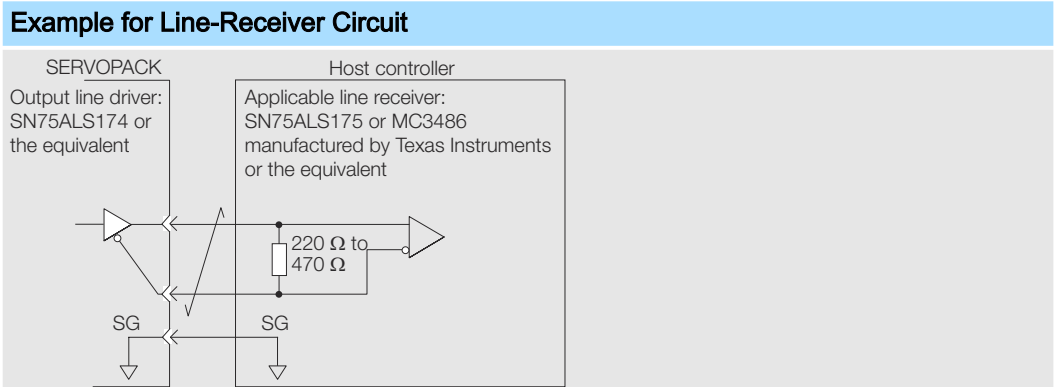
The maximum allowable voltage and current range for photocoupler output circuits are as follows:

- *Maximum allowable voltage: 30 VDC*
- *Current range: 5 mA to 50 mA DC*

■ Line-Driver Output Circuits

This section describes CN1 connector terminals 17-18 (Phase-A Signal), 19-20 (Phase-B Signal), and 21-22 (Phase-C Signal).

The serial data from the encoder is converted to two-phase (phases A and B) pulses. The resulting output signals (PAO, /PAO and PBO, /PBO) and origin pulse signal (PCO and /PCO) are output with line-driver output circuits. Connect the line-driver output circuits to line-receiver circuits at the host controller.



5.7 Connecting Safety Function Signals

5.7.1 Overview

This section describes the wiring required to use a safety function.

Refer to the following chapter for details on the safety function.

→ Chap. 12.1 'Safety Functions' ...page 440

5.7.2 Pin Arrangement of Safety Function Signals (CN8)

Pin No.	Signal	Name	Function
1	-	- (Do not use these pins because they are connected to internal circuits.)	
2	-		
3	/HWBB1-	Hard Wire Base Block Input 1	For a hard wire base block input. The base block (motor power turned OFF) is in effect when the signal is OFF.
4	/HWBB1+		
5	/HWBB2-	Hard Wire Base Block Input 2	
6	/HWBB2+		
7	EDM1-	External Device Monitor Output	Turns ON when the /HWBB1 and the / HWBB2 signals are input and the SERVOPACK enters a base block state.
8	EDM1+		

5.7.3 I/O Circuits



For safety function signal connections, the input signal is the 0-V common and the output signal is a source output. This is opposite to other signals described in this manual.

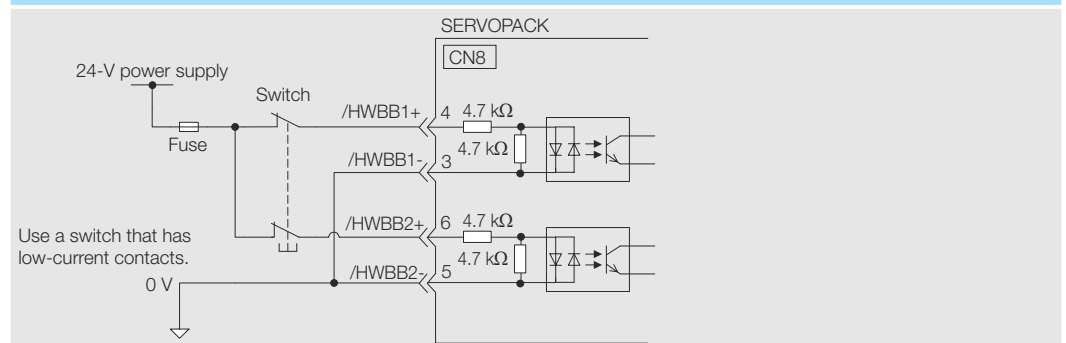
To avoid confusion, the ON and OFF status of signals for the safety function are defined as follows:

- ON: The state in which the relay contacts are closed or the transistor is ON and current flows into the signal line.
- OFF: The state in which the relay contacts are open or the transistor is OFF and no current flows into the signal line.

Safety Input Circuits

Use a 0-V common to connect the safety function signals. You must connect redundant input signals.

Input Signal Connection Example



Input (HWBB) Signal Specifications

Type	Signal	Connector Pin No.	Status	Meaning
Inputs	/HWBB1	CN8-4 CN8-3	ON (closed)	Does not activate the HWBB (normal operation).

Type	Signal	Connector Pin No.	Status	Meaning
			OFF (open)	Activates the HWBB (motor current shut-OFF request).
	/HWBB2	CN8-6 CN8-5	ON (closed)	Does not activate the HWBB (normal operation).
			OFF (open)	Activates the HWBB (motor current shut-OFF request).

The input (HWBB) signals have the following electrical characteristics.

Item	Characteristics	Remarks
Internal Impedance	4.7 kΩ	–
Operating Voltage Range	+24 V ±20%	–
Maximum Delay Time	8 ms	Time from /HWBB1 and /HWBB2 signals turning OFF until HWBB is activated

Diagnostic Output Circuits

The EDM1 output signal uses a source circuit. The following figure shows a connection example.

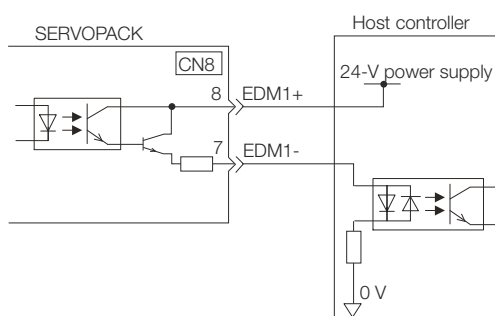


Fig. 83: Diagnostic Output Circuit - Connection Example

EDM1 Output Signal Specifications

Type	Signal	Pin No.	Output Status	Meaning
Output	EDM1	CN8-8 CN8-7	ON	Both the /HWBB1 and /HWBB2 signals are operating normally.
			OFF	The /HWBB1 signal, the /HWBB2 signal, or both are not operating.

The electrical characteristics of the EDM1 signal are as follows:

Item	Characteristics	Remarks
Maximum Allowable Voltage	30 VDC	–
Maximum Allowable Current	50 mA DC	–
Maximum ON Voltage Drop	1.0 V	Voltage between EDM1+ and EDM1- when current is 50 mA

Item	Characteristics	Remarks
Maximum Delay Time	8 ms	Time from a change in /HWBB1 or /HWBB2 until a change in EDM1

5.8 Connecting PROFINET Communications Cables

5.8.1 Overview

Connect the PROFINET Communications Cables to the CN6A and CN6B connectors.

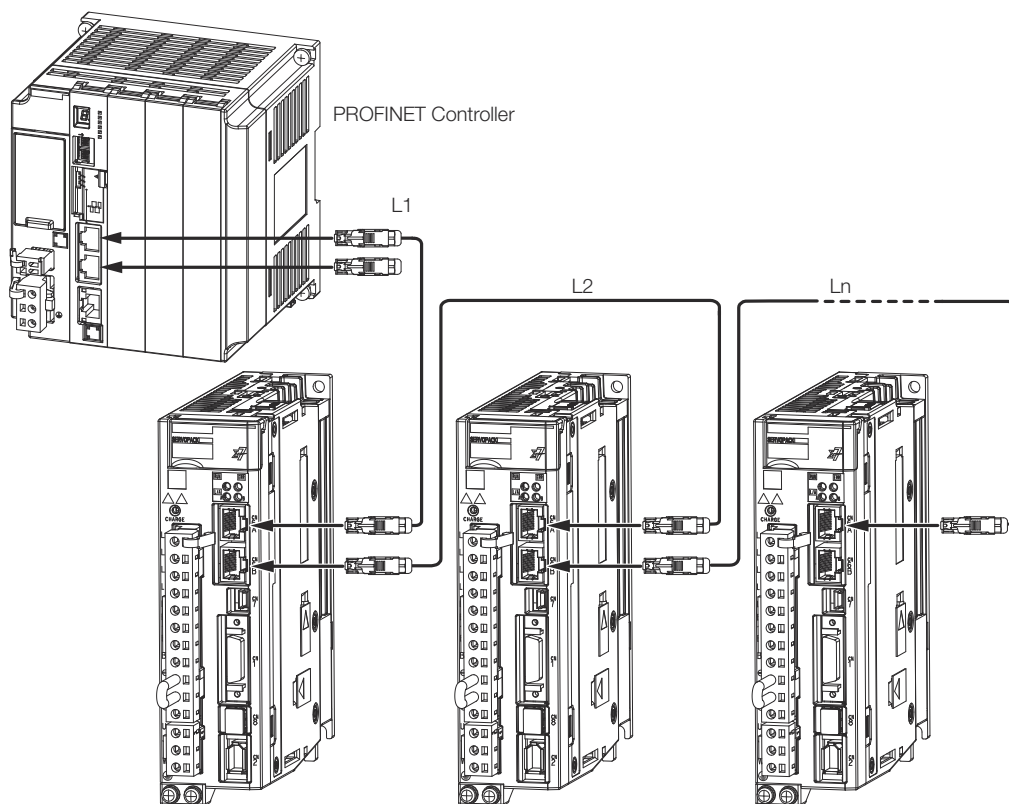


Fig. 84: Connecting PROFINET Communications Cables



The length of the cable between stations (L1, L2, ... Ln) must be 50 m or less.

5.8.2 PROFINET Connectors (RJ45)

Connector	Description
CN6A	PROFINET input signals
CN6B	PROFINET output signals

Connector Pin Assignments

Pin	Signal	Remarks
1	TD+	Send data
2	TD-	
3	RD+	Receive data
4	–	N.C.*
5	–	N.C.*
6	RD-	Receive data

Pin	Signal	Remarks
7	–	N.C.*
8	–	N.C.*

* These pins are not connected to any signals.

5.8.3 Ethernet Communications Cables

Use category 5e Ethernet communications cables to make the connections.

Use cables with the following specifications.

Shielded: S/STP or S/UTP

Length: 50 m max. (between nodes)

5.9 Connecting the Other Connectors

5.9.1 Serial Communications Connector (CN502)

To use an RS-422 cable to connect a Digital Operator, connect a JUSP-JC001-1 Communications Unit to CN502 on the SERVOPACK and connect the RS-422 cable to the Communications Unit.

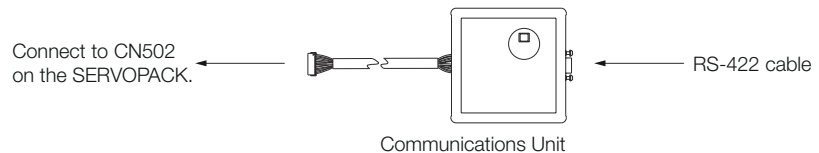


Fig. 85: Connecting a JUSP-JC001-1 Communications Unit to CN502

Communications Unit

Item	Description
Inquiries	Your Yaskawa representative
Order Number	JUSP-JC001-1
External Dimensions	<p>Approx. mass: 0.08 kg Unit: mm</p>


Refer to the following manual for the operating procedures for the Digital Operator.

Σ-7-Series Servo Drive Digital Operator Operating Manual (Manual No.: SIEP S800001 33)

5.9.2 Computer Connector (CN7)

To use the SigmaWin+ Engineering Tool, connect the computer on which the SigmaWin+ is installed to CN7 on the SERVOPACK.

Refer to the following manual for the operating procedures for the SigmaWin+.

 AC Servo Drive Engineering Tool SigmaWin+ Operation Manual (Manual No.: SIET S800001 34)



Use the YASKAWA-specified cables. Operation will not be dependable due to low noise resistance with any other cable.

Refer to the catalog for details on the Computer Cable.

5.9.3 Analog Monitor Connector (CN5)

To use an analog monitor, connect CN5 on the SERVOPACK.

■ Wiring Example

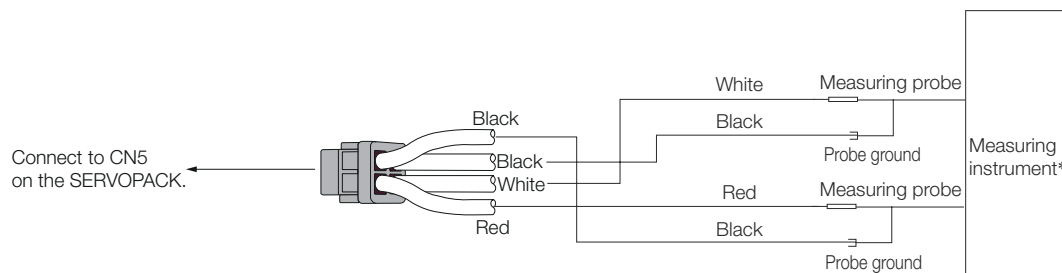


Fig. 86: Analog Monitor Connector (CN5) - Wiring Example

* The measuring instrument is not provided by YASKAWA.

Refer to the following section for information on the monitoring methods for an analog monitor.

[➔ Chap. 10.4.1 'Monitoring Machine Operation Status and Signal Waveforms' ...page 415](#)

6 Basic Functions That Require Setting before Operation

6.1 Overview

This chapter describes the basic functions that must be set before you start servo system operation. It also describes the setting methods.

6.2 Manipulating SERVOPACK Parameters (Pn□□□)

6.2.1 Overview

This section describes the classifications, notation, and setting methods for the SERVOPACK parameters given in this manual.

6.2.2 Classifications of SERVOPACK Parameters

There are the following two types of SERVOPACK parameters.

Classification	Meaning
Setup Parameters	Parameters for the basic settings that are required for operation.
Tuning Parameters	Parameters that are used to adjust servo performance.



When you edit parameters with the SigmaWin+, setup parameters and tuning parameters are displayed.

When you edit parameters with a Digital Operator, only setup parameters are displayed by default. To edit tuning parameters, set Pn00B to n.□□□1 (Display all parameters).

Parameter	Meaning	When Enabled	Classification
Pn00B	n.□□□0 (default setting)	After restart	Setup
	n.□□□1		

The setting method for each type of parameter is described below.

Setup Parameters

You can use the Digital Operator, or SigmaWin+ to set the setup parameters individually.



We recommend that you use the Setup Wizard of the SigmaWin+ to easily set the required setup parameters by setting the operating methods, machine specifications, and I/O signals according to on-screen Wizard instructions.

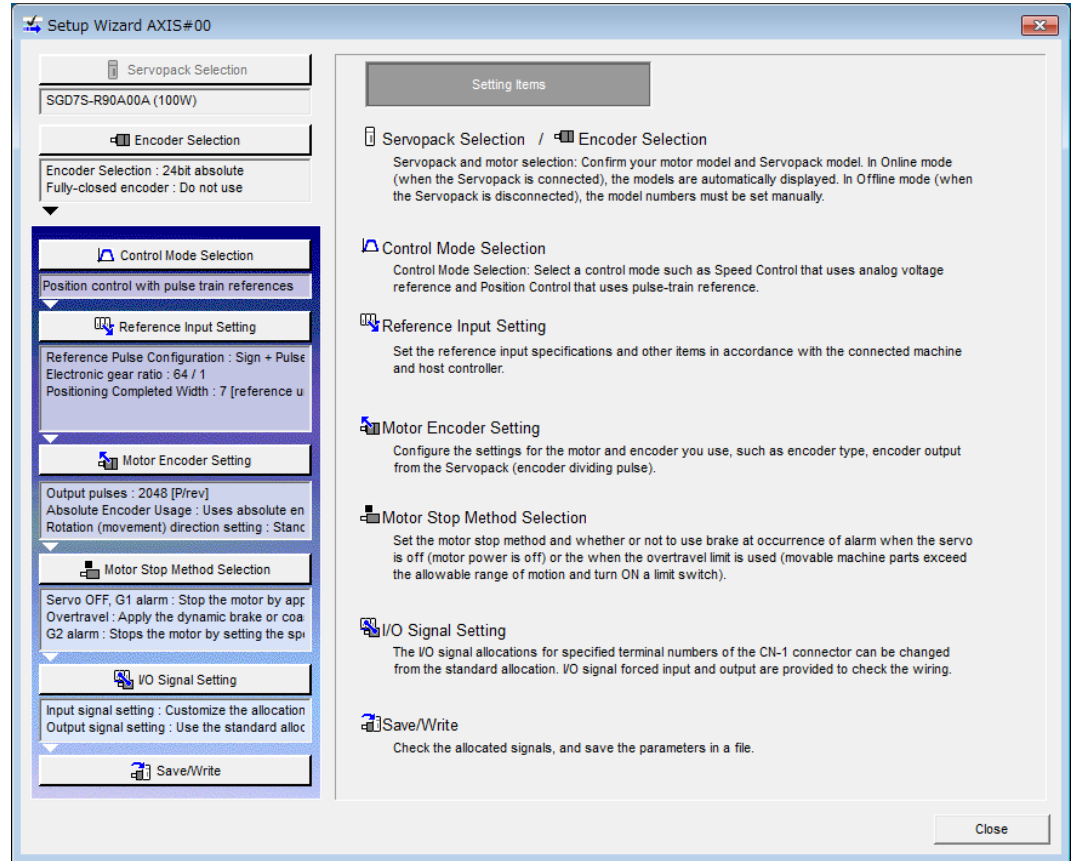


Fig. 87: Setup Wizard of the SigmaWin+

Tuning Parameters

Normally the user does not need to set the tuning parameters individually.

Use the various SigmaWin+ tuning functions to set the related tuning parameters to increase the response even further for the conditions of your machine. Refer to the following sections for details.

→ [Chap. 9.7.1 'Autotuning without Host Reference' ...page 306](#)

→ [Chap. 9.8.1 'Autotuning with a Host Reference' ...page 322](#)

→ [Chap. 9.9.1 'Custom Tuning' ...page 332](#)

You can also set the tuning parameters individually to make adjustments. Refer to the following section for details.

→ [Chap. 9.14.1 'Manual Tuning' ...page 384](#)

6.2.3 Notation for SERVOPACK Parameters

There are two types of notation used for SERVOPACK parameters that depend on whether the parameter requires a numeric setting (parameter for numeric setting) or requires the selection of a function (parameter for selecting a function).

Manipulating SERVOPACK Parameters (Pn□□□) > Setting Methods for SERVOPACK Parameters

Parameters for Numeric Settings

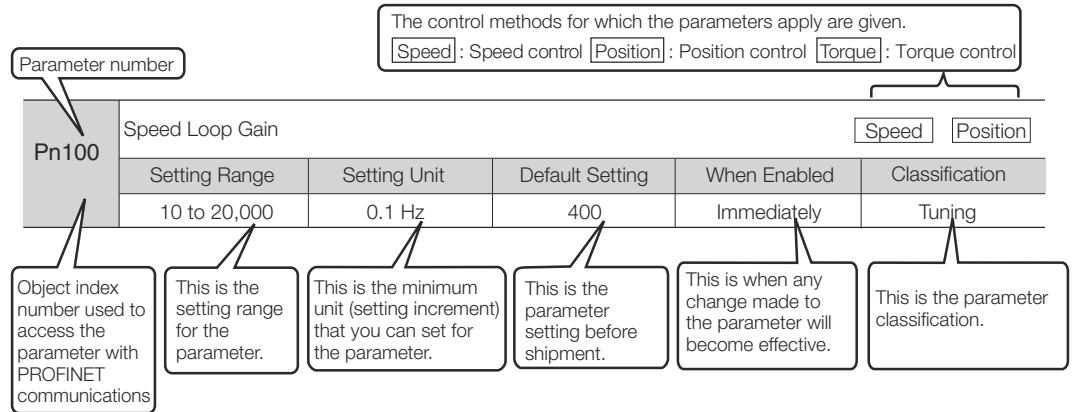


Fig. 88: Notation - Parameters for Numeric Settings

Parameters for Selecting Functions

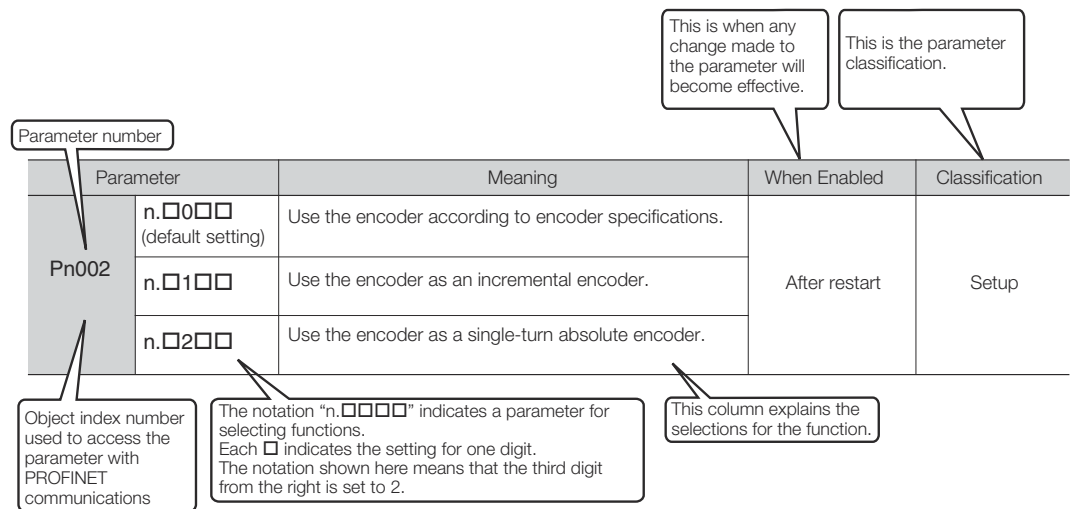


Fig. 89: Notation - Parameters for Selecting Functions

6.2.4 Setting Methods for SERVOPACK Parameters

You can use the SigmaWin+ or a Digital Operator to set the SERVOPACK parameters. A sample operating procedure is given below.

Setting SERVOPACK Parameters with the SigmaWin+

1. Click the Servo Drive Button in the workspace of the Main Window of the SigmaWin+.
2. Select Edit Parameters in the Menu Dialog Box.
The Parameter Editing Dialog Box will be displayed.
3. Click the cell of the parameter to edit.
If the parameter to edit is not displayed in the Parameter Editing Dialog Box, click the or Button to display the parameter to edit.

Manipulating SERVOPACK Parameters (Pn□□□) > Setting Methods for SERVOPACK Parameters

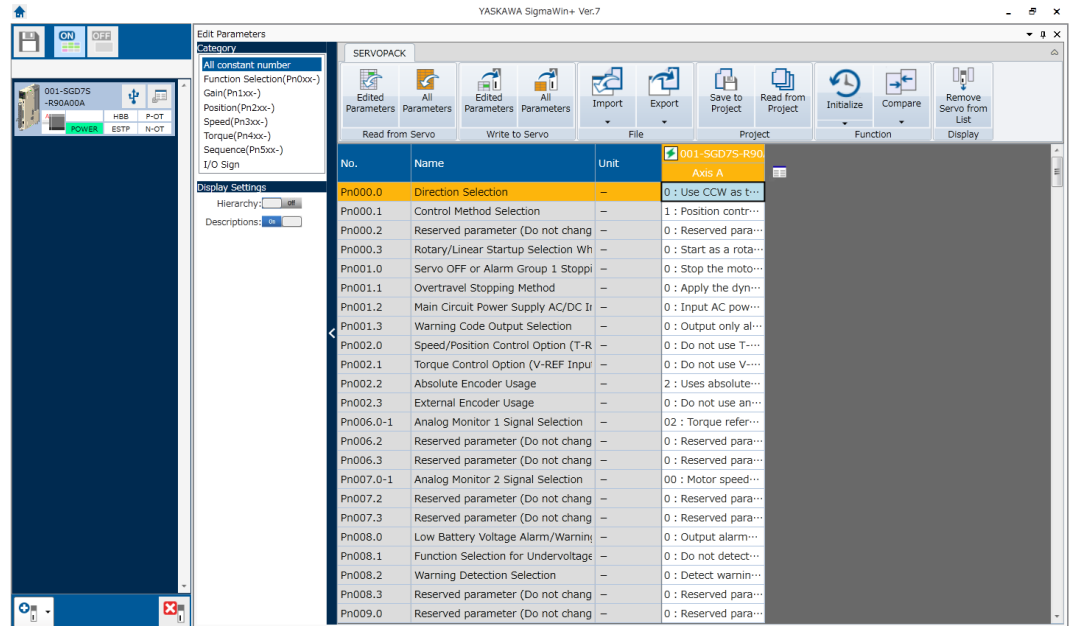


Fig. 90: Select Edit Parameters in the Menu Dialog Box of SigmaWin+

4. Change the setting of the parameter.

i

- For a parameter for a numeric setting, input the numeric setting.
- If the parameter requires selection of a function, select the function from the list of selections.

5. Press the Enter Key.

The background of the edited parameter cell will change to green.

6. Select Edited Parameters in the Write to Servo Group.

The edited parameters are written to the SERVOPACK and the backgrounds of the cells change to white.

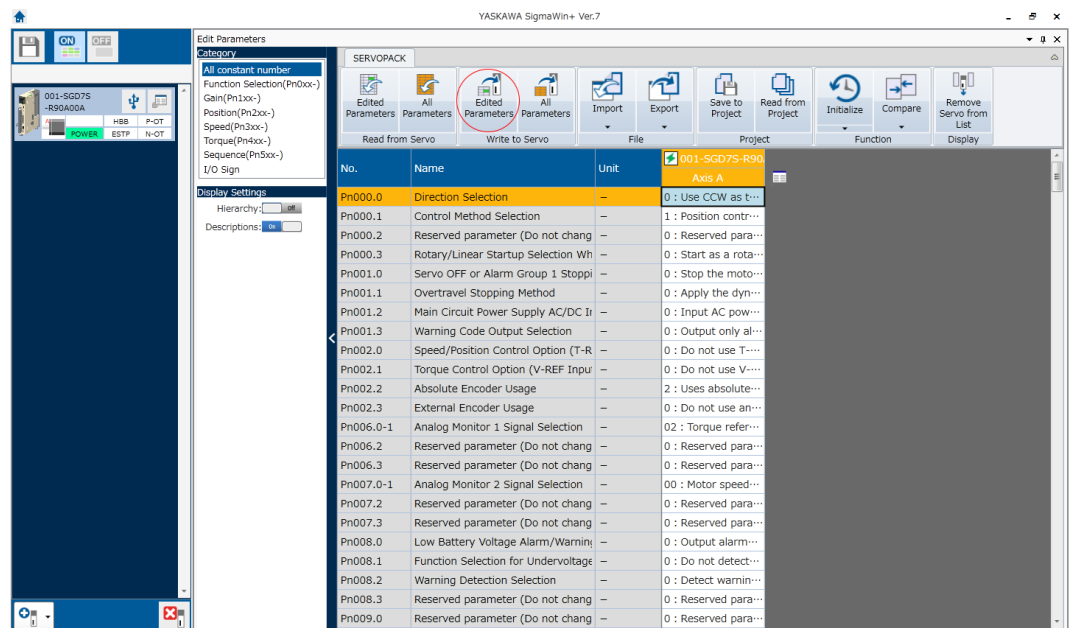


Fig. 91: Select Edited Parameters in the Write to Servo Group of SigmaWin+

7. Click the OK Button.

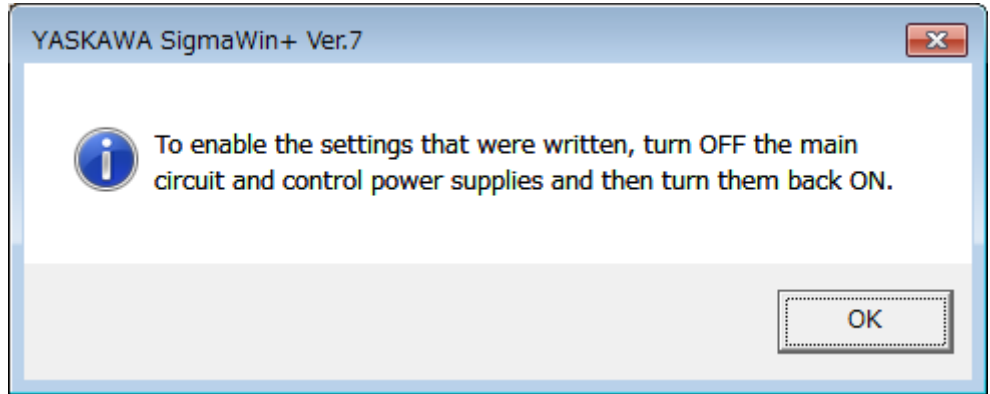


Fig. 92: Enable the Settings Message in SigmaWin+

8. To enable changes to the settings, turn the power supply to the SERVOPACK OFF and ON again.

This concludes the procedure to set the parameters.

Setting SERVOPACK Parameters with a Digital Operator

Refer to the following manual for information on setting the SERVOPACK parameters with a Digital Operator.

Name	Manual number
Σ-7-Series Digital Operator Operating Manual	SIEP S800001 33

Setting internal SERVOPACK Parameters (Pn□□□) with PROFINET Communications

The following objects can be used to **set** the internal SERVOPACK parameters or to **get** them from the SERVOPACK:

- Get internal SERVOPACK Parameter with PROFINET Communications
 - 2100h: Get parameter - Parameter Identify
 - 2101h: Get parameter - Parameter Value
- Set internal SERVOPACK Parameter with PROFINET Communications
 - 2102h: Set parameter - Parameter Identify
 - 2103h: Set parameter - Parameter Value

Refer to the following section for further information on this functionality.

→ [Chap. 14.11 'Get/Set SERVOPACK Parameter Functionality' ...page 492](#)

6.2.5 Write Prohibition Setting for SERVOPACK Parameters

You can prohibit writing SERVOPACK parameters from a Digital Operator. Even if you do, you will still be able to change SERVOPACK parameter settings from the SigmaWin+ or with PROFINET communications.

Preparations

No preparations are required.

Applicable Tools


The following table lists the tools that you can use to change the write prohibition setting for SERVOPACK parameters and the applicable tool functions.

Tool	Function	Reference
Digital Operator	Fn010	Σ-7-Series Digital Operator Operating Manual (Manual No.: SIEP S800001 33)

Tool	Function	Reference
SigmaWin+	Setup - Write Prohibited Setting	→ 'Operating Procedure' ...page 132

Operating Procedure

Use the following procedure to prohibit or permit writing parameters.

1. Click the  Servo Drive Button in the workspace of the Main Window of the SigmaWin+.
2. Select Write Prohibition Setting in the Menu Dialog Box.
The Write Prohibition Setting Dialog Box will be displayed.
3. Press the ▲ or ▼ for the rightmost digit and set one of the following.
0000: Writing is permitted (default setting).
0001: Writing is prohibited.

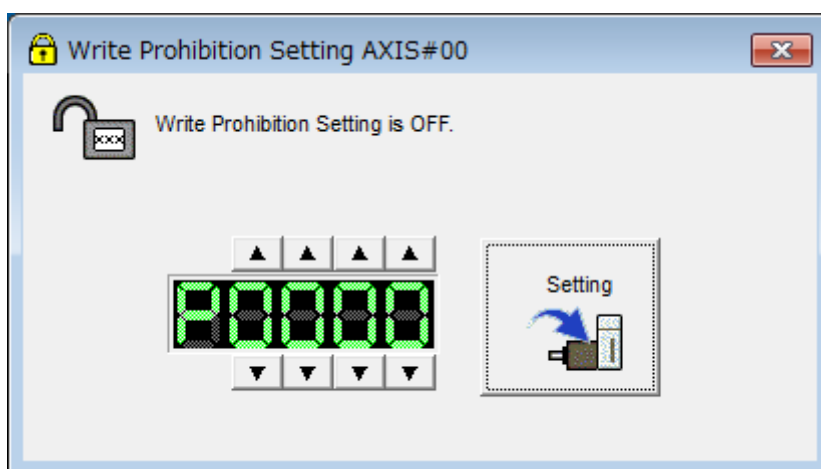


Fig. 93: Writing is permitted SigmaWin+

4. Click the Setting Button.

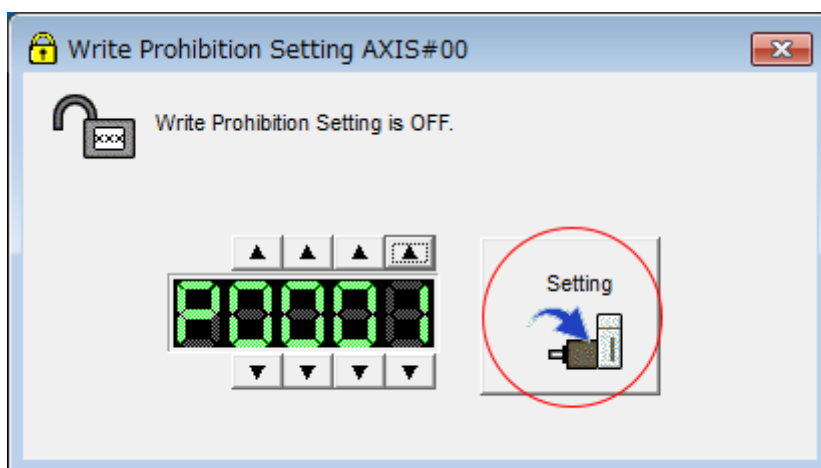


Fig. 94: Writing is prohibited SigmaWin+

5. Click the OK Button.
The setting will be written to the SERVOPACK.

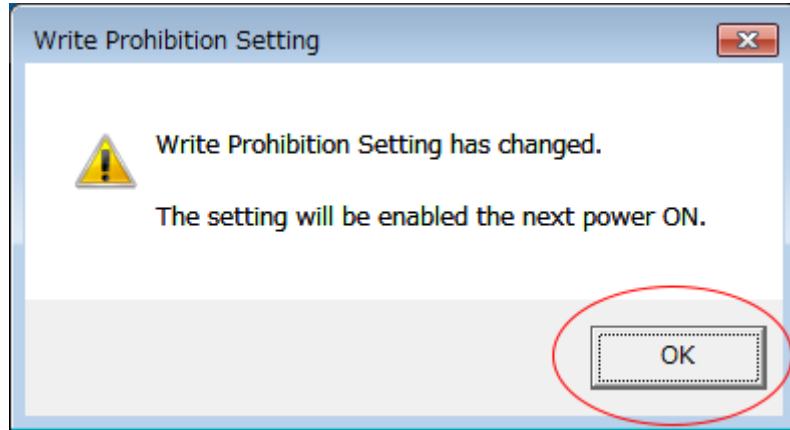


Fig. 95: Write Prohibition Setting - OK Button - SigmaWin+

6. To enable the new setting, turn the power supply to the SERVOPACK OFF and ON again.

This concludes the procedure to prohibit or permit writing parameter settings.

Restrictions

If you prohibit writing parameter settings, you will no longer be able to execute some functions. Refer to the following table.

SigmaWin+		Digital Operator		When Writing Is Prohibited	Reference
Menu Dialog Box Button	SigmaWin+ Function Name	Fn No.	Utility Function Name		
Setup	Origin Search*1	Fn003	Origin Search	Cannot be executed.	↪ Chap. 8.7.3 'Origin Search' ...page 272
	Absolute Encoder Reset	Fn008	Reset Absolute Encoder	Cannot be executed.	↪ Chap. 6.16.5 'Operating Procedure' ...page 180
	Adjusting the Analog Monitor Output	Fn00C	Adjust Analog Monitor Output Offset	Cannot be executed.	↪ Chap. 10.4.4 'Using the Analog Monitors' ...page 418
		Fn00D	Adjust Analog Monitor Output Gain	Cannot be executed.	
	Motor Current Detection Offset Adjustment	Fn00E	Autotune Motor Current Detection Signal Offset	Cannot be executed.	↪ Chap. 7.13.2 'Automatic Adjustment' ...page 241
		Fn00F	Manually Adjust Motor Current Detection Signal Offset	Cannot be executed.	

Manipulating SERVOPACK Parameters (Pn□□□) > Write Prohibition Setting for SERVOPACK Parameters

SigmaWin+		Digital Operator		When Writing Is Prohibited	Reference
Menu Dialog Box Button	SigmaWin+ Function Name	Fn No.	Utility Function Name		
	Multiturn Limit Setting	Fn013	Multiturn Limit Setting after Multiturn Limit Disagreement Alarm	Cannot be executed.	↪ Chap. 7.9.9 'Multiturn Limit Disagreement Alarm (A.CC0)' ...page 225
	Reset Configuration Error of Option Module	Fn014	Reset Option Module Configuration Error	Cannot be executed.	↪ Chap. 16.4.7 'Resetting Alarms Detected in Option Modules' ...page 597
	Vibration Detection Level Initialization	Fn01B	Initialize Vibration Detection Level	Cannot be executed.	↪ Chap. 7.12.1 'Initializing the Vibration Detection Level' ...page 236
	Set Origin	Fn020	Set Absolute Linear Encoder Origin	Cannot be executed.	↪ Chap. 6.17.1 'Setting the Origin of the Absolute Encoder' ...page 183
	Software Reset	Fn030	Software Reset	Cannot be executed.	↪ Chap. 7.11.1 'Software Reset' ...page 233
	Polarity Detection	Fn080	Polarity Detection	Cannot be executed.	↪ Chap. 6.10.4 'Using a Tool Function to Perform Polarity Detection' ...page 154
	Tuning-less Level Setting	Fn200	Tuning-less Level Setting	Cannot be executed.	↪ Chap. 9.6.1 'Estimating the Moment of Inertia' ...page 295
	EasyFFT	Fn206	Easy FFT	Cannot be executed.	↪ Chap. 9.15.2 'Easy FFT' ...page 403

Manipulating SERVOPACK Parameters (Pn□□□) > Write Prohibition Setting for SERVOPACK Parameters

SigmaWin+		Digital Operator		When Writing Is Prohibited	Reference
Menu Dialog Box Button	SigmaWin+ Function Name	Fn No.	Utility Function Name		
Parameters	Initialize*2	Fn005	Initialize Parameters	Cannot be executed.	↪ Chap. 6.2.6 'Initializing SERVOPACK Parameter Settings' ...page 136
Tuning	Autotuning without Reference Input	Fn201	Advanced Autotuning without Reference	Cannot be executed.	↪ Chap. 9.7.1 'Autotuning without Host Reference' ...page 306
	Autotuning with Reference Input	Fn202	Advanced Autotuning with Reference	Cannot be executed.	↪ Chap. 9.8.1 'Autotuning with a Host Reference' ...page 322
	Custom Tuning	Fn203	One-Parameter Tuning	Cannot be executed.	↪ Chap. 9.9.1 'Custom Tuning' ...page 332
	Anti-Resonance Control Adjustment	Fn204	Adjust Anti-resonance Control	Cannot be executed.	↪ Chap. 9.10.1 'Anti-Resonance Control Adjustment' ...page 347
	Vibration Suppression	Fn205	Vibration Suppression	Cannot be executed.	↪ Chap. 9.11.1 'Vibration Suppression' ...page 355
Monitor	Product Information	Fn011	Display Servomotor Model	Can be executed.	↪ Chap. 10.2.1 'Monitoring Product Information' ...page 410
		Fn012	Display Software Version	Can be executed.	
		Fn01E	Display SERVOPACK and Servomotor IDs	Can be executed.	

Manipulating SERVOPACK Parameters (Pn□□□) > Initializing SERVOPACK Parameter Settings

SigmaWin+		Digital Operator		When Writing Is Prohibited	Reference
Menu Dialog Box Button	SigmaWin+ Function Name	Fn No.	Utility Function Name		
		Fn01F	Display Servomotor ID from Feedback Option Module	Can be executed.	
Test Operation	Jogging	Fn002	Jog	Cannot be executed.	↪ Chap. 8.4.1 'Trial Operation for the Servomotor without a Load' ...page 255
	Program Jogging	Fn004	Jog Program	Cannot be executed.	↪ Chap. 8.7.1 'Convenient Function to Use during Trial Operation' ...page 264
Alarm	Display Alarm	Fn000	Display Alarm History	Can be executed.	↪ Chap. 16.4.5 'Displaying the Alarm History' ...page 594
		Fn006	Clear Alarm History	Cannot be executed.	↪ Chap. 16.4.6 'Clearing the Alarm History' ...page 596
	Reset Motor Type Alarm	Fn021	Reset Motor Type Alarm	Cannot be executed.	↪ Chap. 6.4 'Automatic Detection of Connected Motor' ...page 140

*1. Cannot be used when connecting a Linear Servomotor.

*2. An **Initialize** Button will be displayed in the Parameter Editing Dialog Box.

6.2.6 Initializing SERVOPACK Parameter Settings

You can return the SERVOPACK parameters to their default settings.

This function will not initialize the settings of the parameters that are adjusted for the Fn00C, Fn00D, Fn00E, and Fn00F utility functions.



To enable the new settings, turn the power supply to the SERVOPACK OFF and ON again after you complete the operation.

Preparations

Check the following settings before you initialize the SERVOPACK parameter settings.

- The SERVOPACK parameters must not be write prohibited.
- The servo must be OFF.

Applicable Tools

The following table lists the tools that you can use to initialize the SERVOPACK parameter settings and the applicable tool functions.

Tool	Function	Reference
Digital Operator	Fn005	Σ-7-Series Digital Operator Operating Manual (Manual No.: SIEP S800001 33)
SigmaWin+	Parameters - Edit Parameters	→ 'Operating Procedure' ...page 137

Operating Procedure

Use the following procedure to initialize the parameter settings.

1. Click the Servo Drive Button in the workspace of the Main Window of the SigmaWin+.
2. Select Edit Parameters in the Menu Dialog Box.
The Parameter Editing Dialog Box will be displayed.
3. Select any parameter of the axis to initialize.
4. Click the **Initialize** in the **Function** Group.

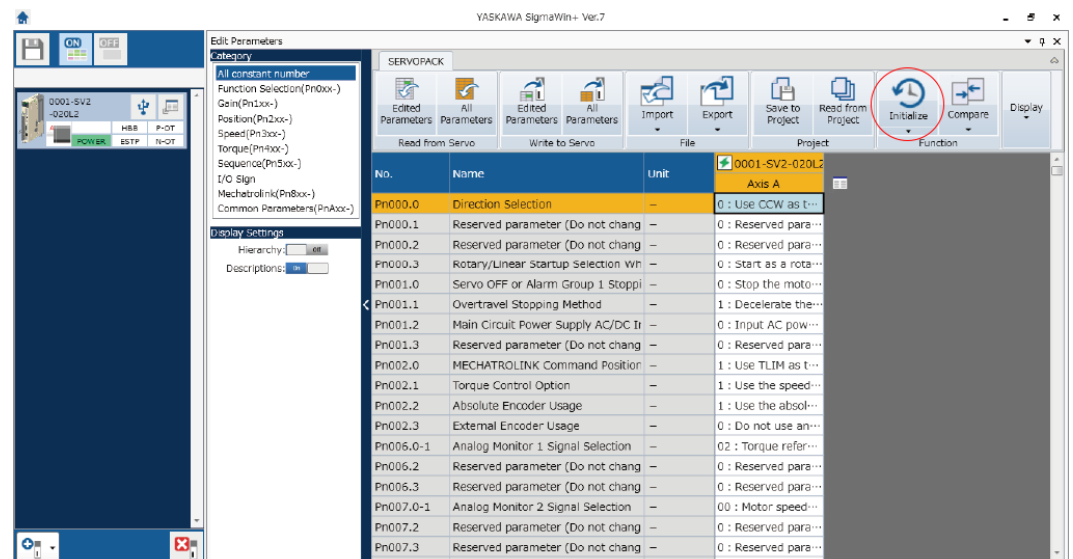


Fig. 96: Initializing SERVOPACK Parameter Settings - SigmaWin+

5. Click the OK Button.

Click the Cancel Button to cancel initialization. The Parameter Editing Dialog Box will return.

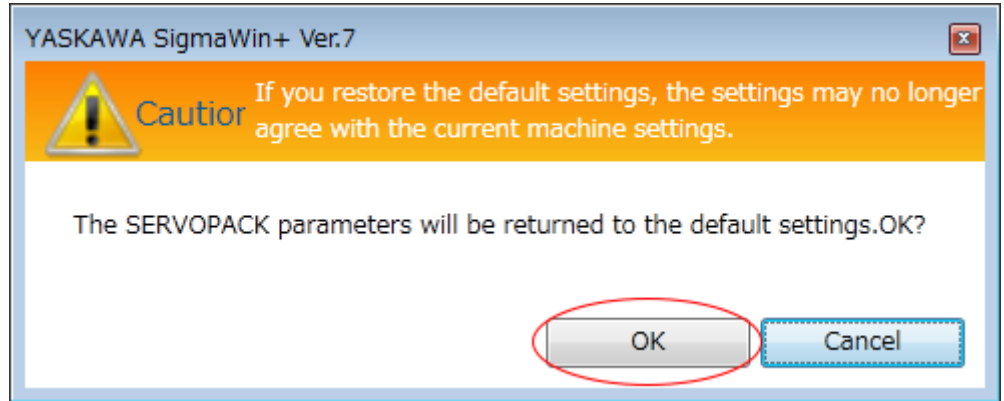


Fig. 97: Dialog box SigmaWin+ - The SERVOPACK parameters will be returned to the default settings.

6. Click the OK Button.

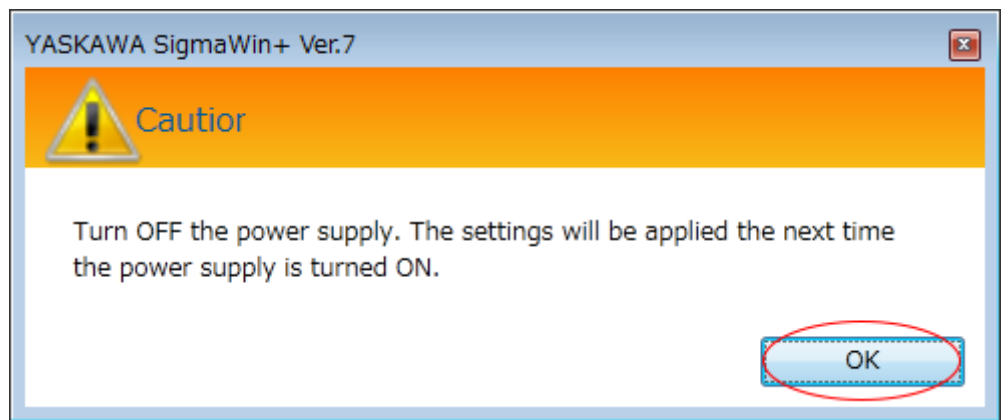


Fig. 98: Dialog box SigmaWin+ - The settings will be applied the next time the power supply is turned ON.

7. Turn the power supply to the SERVOPACK OFF and ON again after the parameter settings have been initialized.

This concludes the procedure to initialize the parameter settings.

6.3 Power Supply Type Settings for the Main Circuit and Control Circuit

6.3.1 Overview

A SERVOPACK with a 200-VAC power supply input can be operated on either an AC power supply input or DC power supply input to the main and control circuits. If you select an AC power supply input, you can operate the SERVOPACK on either a single-phase power supply input or a three-phase power supply input. This section describes the settings related to the power supply.



You cannot input DC power to a SERVOPACK with a single-phase, 100-VAC power supply input.

6.3.2 AC Power Supply Input/DC Power Supply Input Setting

Set Pn001 = n.XXX (Main Circuit Power Supply AC/DC Input Selection) to specify whether to use an AC or DC power supply input for the main circuit power supply to the SERVOPACK.

If the setting of Pn001 = n.□X□□ does not agree with the actual power supply input, an A.330 alarm (Main Circuit Power Supply Wiring Error) will occur.

Example

Examples of When an A.330 Alarm (Main Circuit Power Supply Wiring Error) Occurs

- A DC power supply is connected between the B1/⊕ and ⊖2 terminals, but an AC power supply input is specified (Pn001 = n.□0□□).
- An AC power supply is input to the L1, L2, and L3 terminals, but a DC power supply is specified (Pn001 = n.□1□□).

Parameter		Meaning	When Enabled	Classification
Pn001	n.□0□□ (default setting)	Use an AC power supply input.	After restart	Setup
	n.□1□□	Use a DC power supply input.		

**WARNING**

- Connect the AC or DC power supplies to the specified SERVOPACK terminals.
 - Connect an AC power supply to the L1, L2, and L3 terminals and the L1C and L2C terminals on the SERVOPACK.
 - Connect a DC power supply to the B1/⊕ and ⊖2 terminals and the L1C and L2C terminals on the SERVOPACK.

There is a risk of failure or fire.
- Always specify a DC power supply input (Pn001 = n.□1□□) before you input DC power for the main circuit power supply.

If you input DC power without specifying a DC power supply input (i.e., without setting Pn001 to n.□1□□), the SERVOPACK's internal elements may burn and may cause fire or damage to the equipment.
- With a DC power supply input, time is required to discharge electricity after the main power supply is turned OFF. A high residual voltage may remain in the SERVOPACK after the power supply is turned OFF. Be careful not to get an electric shock.
- Install fuses on the power supply line if you use DC power.
- The Servomotor returns regenerative energy to the power supply. If you use a SERVOPACK with a DC power supply input, regenerative energy is not processed. Process the regenerative energy at the power supply.
- If you use a DC power supply input with any of the following SERVOPACKs, externally connect an inrush current limiting circuit and use the power ON and OFF sequences recommended by Yaskawa: SGD7S-330A, -470A, -550A, -590A, or -780A.

There is a risk of equipment damage.

Refer to the following section for the power ON and OFF sequences.

→ [Chap. 5.4.4 'Power ON Sequence' ...page 95](#)

Refer to the following section for information on wiring the SERVOPACK.

→ [Chap. 5.4.5.1 'Power Supply Wiring Diagrams' ...page 97](#)

6.3.3 Single-phase AC Power Supply Input/Three-phase AC Power Supply Input Setting

Some models of Three-phase 200-VAC SERVOPACKs can also operate on a single-phase 200-VAC power supply.

You can use a single-phase, 200-V power supply input with the following models.

- SGD7S-R70A, -R90A, -1R6A, -2R8A, and -5R5A

Automatic Detection of Connected Motor

If you use a single-phase, 200-VAC power supply input for the SERVOPACK's main circuit power supply, change the setting to specify a single-phase AC power supply input (Pn00B = n.□1□□).



You do not need to change the setting of Pn00B to n.□1□□ (Use a three-phase power supply input as a single-phase power supply input) for a SERVOPACK with a single-phase 200-V power supply input (model numbers: SGD7S-120A□□□008) or for a SERVOPACK with a single-phase 100-V power supply input.

Parameter	Meaning	When Enabled	Classification
Pn00B	n.□0□□ (default setting)	After restart	Setup
	n.□1□□		



- *If you use a single-phase power supply input without specifying a single-phase AC power supply (Pn00B = n.□1□□), an A.F10 alarm (Power Supply Line Open Phase) will occur.*
- *Not all SERVOPACKs can be run on a single-phase AC power supply input. If you connect a single-phase AC power supply input to a SERVOPACK that does not support single-phase power, an A.F10 alarm (Power Supply Line Open Phase) will occur.*
- *If you use a single-phase 200-VAC power supply input, the torque-motor speed characteristic of the Servomotor will not be the same as for a three-phase AC power supply input. Decide whether to use a single-phase or three-phase AC power supply input after checking the characteristics given in the Servomotor manual or catalog.*

Refer to the following section for information on wiring a single-phase AC power supply input to the SERVOPACK.

➔ [Chap. 5.4.5.1 'Power Supply Wiring Diagrams' ...page 97](#)

6.4 Automatic Detection of Connected Motor

You can use a SERVOPACK to operate either a Rotary Servomotor or a Linear Servomotor.

If you connect the Servomotor encoder to the CN2 connector on the SERVOPACK, the SERVOPACK will automatically determine which type of Servomotor is connected. Therefore, you normally do not need to specify the Servomotor type.



If an encoder is not connected, e.g., for a test without a motor, you can specify a Rotary Servomotor or a Linear Servomotor in Pn000 = n.X□□□ (Rotary/Linear Startup Selection When Encoder Is Not Connected). If you specify either a Rotary or Linear Servomotor, only the parameters, monitors, alarms, and functions for the specified motor type will be enabled.

Parameter	Meaning	When Enabled	Classification
Pn000	n.0□□□ (default setting)	After restart	Setup

Parameter	Meaning	When Enabled	Classification
n.1□□□	When an encoder is not connected, start as SERVOPACK for Linear Servomotor.		

6.5 Motor Direction Setting

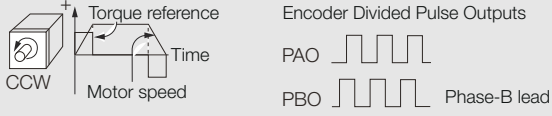
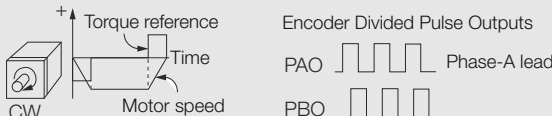
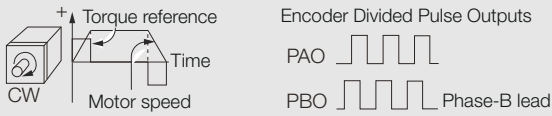
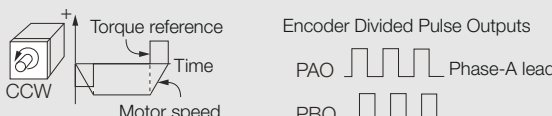
You can reverse the direction of Servomotor rotation by changing the setting of Pn000 = n.□□□X (Direction Selection) without changing the polarity of the speed or position reference. This causes the rotation direction of the motor to change, but the polarity of the signals, such as encoder output pulses, output from the SERVOPACK do not change. Set the appropriate direction for your system.

Refer to the following section for details on the encoder divided pulse output.

→ [Chap. 7.6.1 'Encoder Divided Pulse Output' ...page 204](#)

Rotary Servomotors

The default setting for forward rotation is counterclockwise (CCW) as viewed from the load end of the Servomotor.

Parameter		Forward/ Reverse Refer- ence	Motor Direction and Encoder Divided Pulse Outputs	Applicable Overtravel Signal (OT)
Pn000	n.□□□0 Use CCW as the for- ward direction. (default setting)	Forward refer- ence		P-OT (Forward Drive Prohibit) signal
		Reverse refer- ence		N-OT (Reverse Drive Prohibit) signal
	n.□□□1 Use CW as the for- ward direction. (Reverse Rota- tion Mode)	Forward refer- ence		P-OT (Forward Drive Prohibit) signal
		Reverse refer- ence		N-OT (Reverse Drive Prohibit) signal

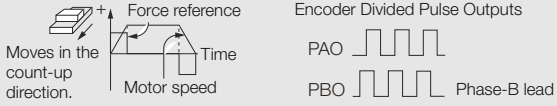
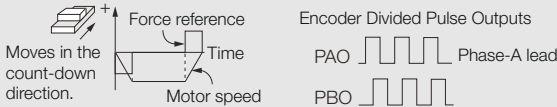
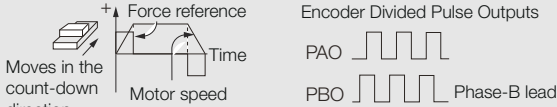
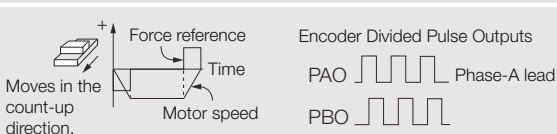


The trace waveforms of the SigmaWin+ are shown in the above table for the torque reference and motor speed diagrams. If you measure them on a measuring instrument, e.g., with an analog monitor, the polarity will be reversed.

Linear Servomotors

Before you set this parameter, make sure that Pn080 = n.□□X□ (Motor Phase Sequence Selection) is set correctly.

Setting the Linear Encoder Pitch

Parameter		Forward/Reverse Reference	Motor Moving Direction and Encoder Divided Pulse Outputs	Applicable Overtravel Signal (OT)
Pn000	n.□□□0 Use the direction in which the linear encoder counts up as the forward direction. (default setting)	Forward reference		P-OT (Forward Drive Prohibit) signal
		Reverse reference		N-OT (Reverse Drive Prohibit) signal
	n.□□□1 Use the direction in which the linear encoder counts down as the forward direction.	Forward reference		P-OT (Forward Drive Prohibit) signal
		Reverse reference		N-OT (Reverse Drive Prohibit) signal



The trace waveforms of the SigmaWin+ are shown in the above table for the force reference and motor speed diagrams. If you measure them on a measuring instrument, e.g., with an analog monitor, the polarity will be reversed.

6.6 Setting the Linear Encoder Pitch

If you connect a linear encoder to the SERVOPACK through a Serial Converter Unit, you must set the scale pitch of the linear encoder in Pn282.

If a Serial Converter Unit is not connected, you do not need to set Pn282.



Serial Converter Unit

The Serial Converter Unit converts the signal from the linear encoder into a form that can be read by the SERVOPACK.

Scale Pitch

A linear encoder has a scale for measuring lengths (positions). The length of one division on this scale is the scale pitch.

Linear Encoder Pitch

	Setting Range	Setting Unit	Default Setting	When Enabled	Classification
Pn282	0 to 6,553,600	0.01 μm	0	After restart	Setup

(applies to Speed Control, Position Control and Force Control)

You will not be able to control the Linear Servomotor if Pn282 is not set correctly. Check the above table and always set the correct value before you operate the Linear Servomotor.

Type of Linear Encoder	Manufacturer	Model	Serial Converter Unit Model	Linear Encoder Pitch [μm]
Incremental	Dr. JOHANNES HEIDENHAIN GmbH	LIDA48□	JZDP-H003-□□□-E	20
			JZDP-J003-□□□-E	
		LIF48□	JZDP-H003-□□□-E	4
			JZDP-J003-□□□-E	
Renishaw PLC	RGH22B		JZDP-H005-□□□-E	20
			JZDP-J005-□□□-E	

The first time you supply power to the SERVOPACK, the panel display on the front of the Servomotor will display an A.080 alarm (Linear Encoder Pitch Setting Error). The A.080 alarm is displayed because the setting of Pn282 has not been changed. The A.080 alarm will be cleared when you change the setting of Pn282 and then turn the power supply OFF and ON again.



Linear Encoder Pitch

If you do not use a Serial Converter Unit, the linear encoder pitch is automatically set. It is not necessary to set Pn282. You can use the SigmaWin+ to check the linear encoder pitch that was automatically set. Refer to the following section for details.

→ Chap. 10.2.1 'Monitoring Product Information' ...page 410

6.7 Writing Linear Servomotor Parameters

If you connect a linear encoder to the SERVOPACK without going through a Serial Converter Unit, you must use the SigmaWin+ to write the motor parameters to the linear encoder. The motor parameters contain the information that is required by the SERVOPACK to operate the Linear Servomotor.

You can download the motor parameters from our web site (<http://www.e-mechatronics.com/>).



WARNING

Check the Servomotor and linear encoder information before you write the motor parameters.

If you do not write the correct motor parameters, the Servomotor may run out of control or burning may occur, possibly resulting in equipment damage or fire.

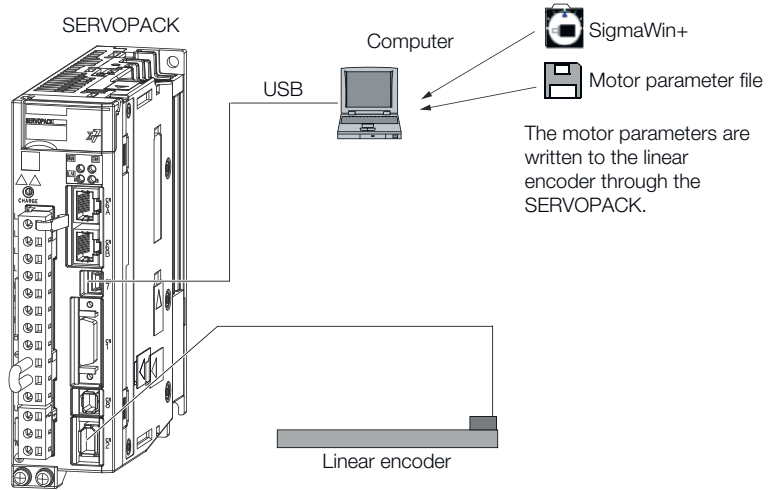


Fig. 99: Writing Linear Servomotor Parameters



Serial number information is not included in the motor parameters. You cannot use the monitor functions of the SERVOPACK to monitor the serial number. If you attempt to monitor the serial number, ***** will be displayed.

Precautions

- If the encoder parameters are not written to the linear encoder, an A.CA0 alarm (Encoder Parameter Error) will occur. Consult the manufacturer of the linear encoder.
- If the motor parameters are not written to the linear encoder, an A.CA0 alarm (Encoder Parameter Error) will not occur, but the following alarms will occur.
 - A.040 (Parameter Setting Error)
 - A.041 (Encoder Output Pulse Setting Error)
 - A.050 (Combination Error)
 - A.051 (Unsupported Device Alarm)
 - A.550 (Maximum Speed Setting Error)
 - A.710 (Instantaneous Overload)
 - A.720 (Continuous Overload)
 - A.C90 (Encoder Communications Error)

Applicable Tools

The following table lists the tools that you can use to write the parameters to the Linear Servomotor and the applicable tool functions.

Tool	Function	Reference
Digital Operator	You cannot write Linear Servomotor parameters from the Digital Operator.	
SigmaWin+	Setup - Motor Parameter Scale Write	↪ 'Operating Procedure' ...page 144

Operating Procedure

Use the following procedure to write the motor parameters to the linear encoder.

1. ➤ Prepare the motor parameter file to write to the linear encoder.
2. ➤ Click the Servo Drive Button in the workspace of the Main Window of the SigmaWin+.
3. ➤ Select **Motor Parameter Scale Write** in the Menu Dialog Box.
 - The Motor Parameter Scale Write Dialog Box will be displayed.

4. → Click the OK Button.

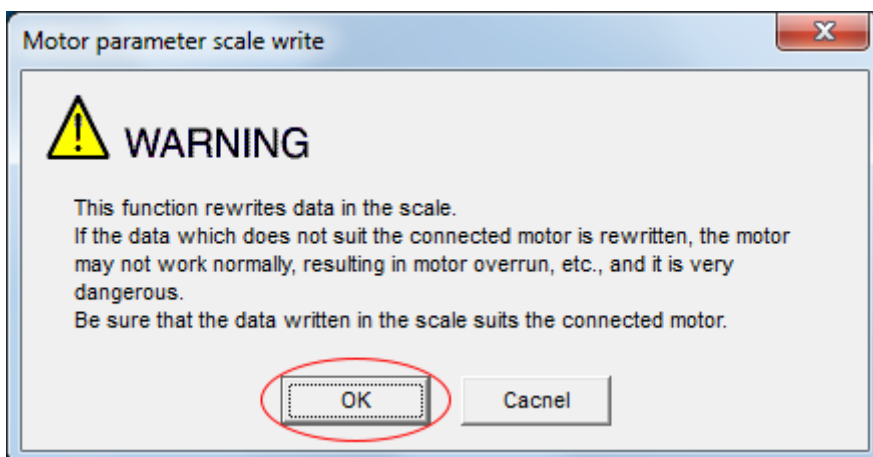


Fig. 100: Motor parameter scale write - Warning

- Click the **Cancel** Button to cancel writing the motor parameters to the linear encoder. The Main Window will return.

If the write is completed normally, the Motor Parameter Scale Write - File Select Dialog Box will be displayed.

5. → Click the Ref. Button.

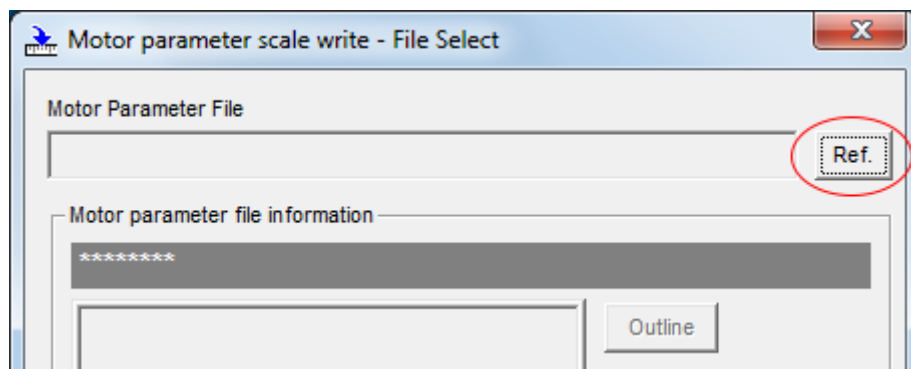


Fig. 101: Motor parameter scale write - File select

6. Select the motor parameter file that you prepared and click the Open Button.

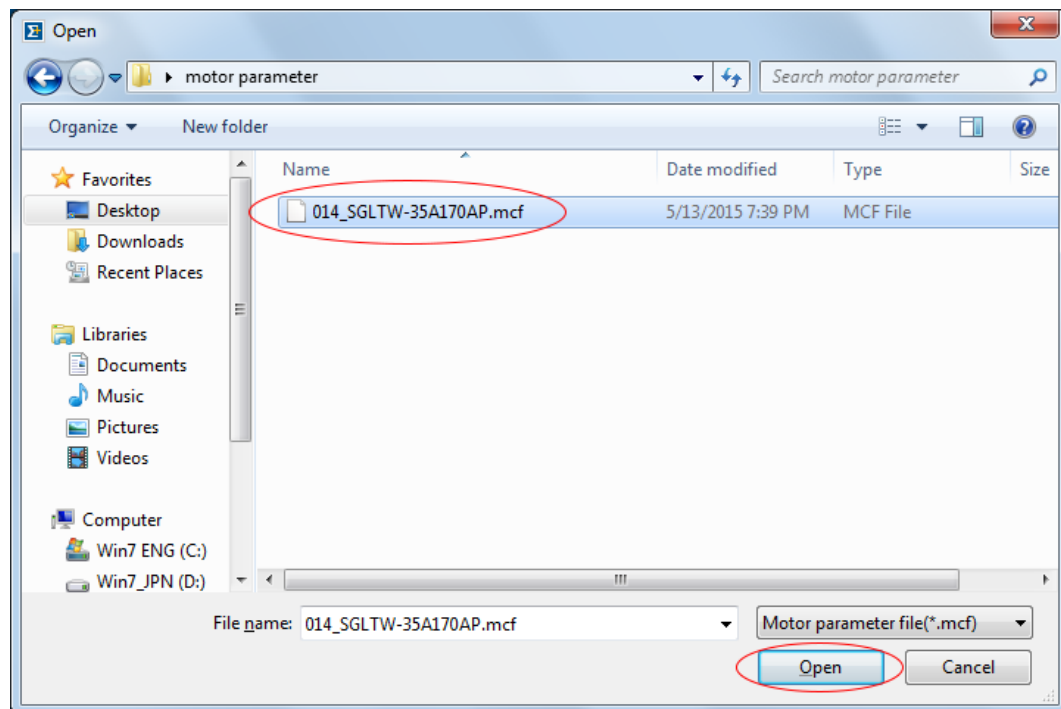


Fig. 102: Open motor parameter file

7. → Confirm that the motor parameter file information that is displayed is suitable for your motor, and then click the Next Button.

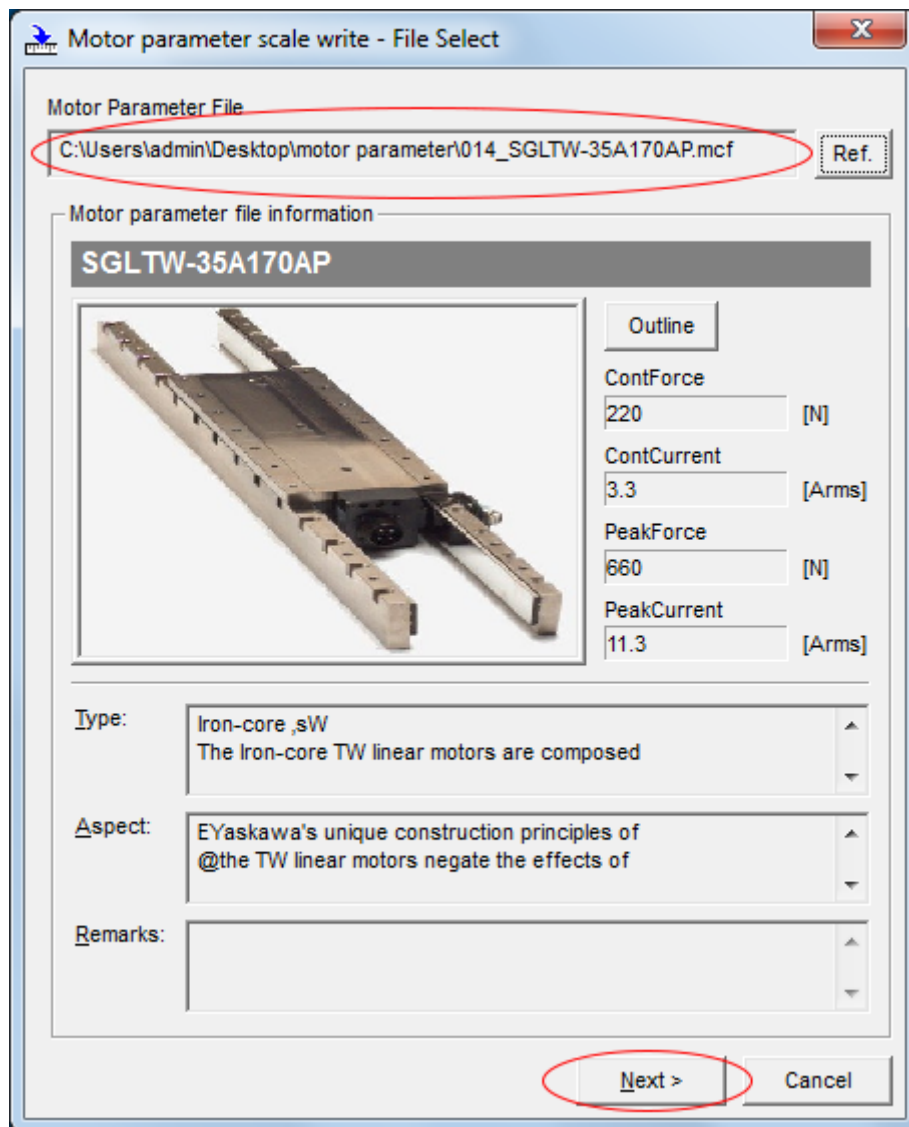


Fig. 103: Confirm the motor parameter file information

- ➔ Click the Cancel Button to cancel writing the motor parameters to the linear encoder. The Main Window will return.

8. Click the Write Button.

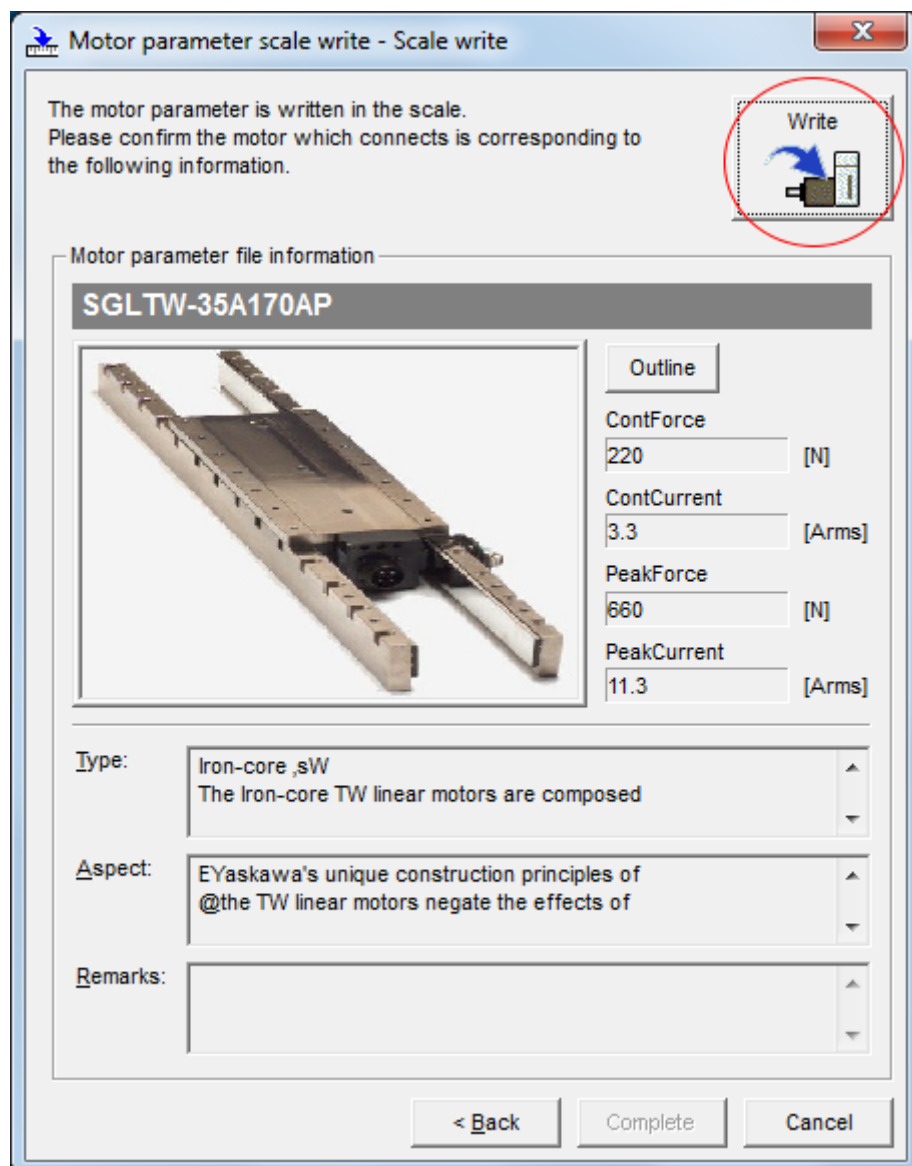


Fig. 104: Motor parameter scale write - Scale write

9. Click the Yes Button.

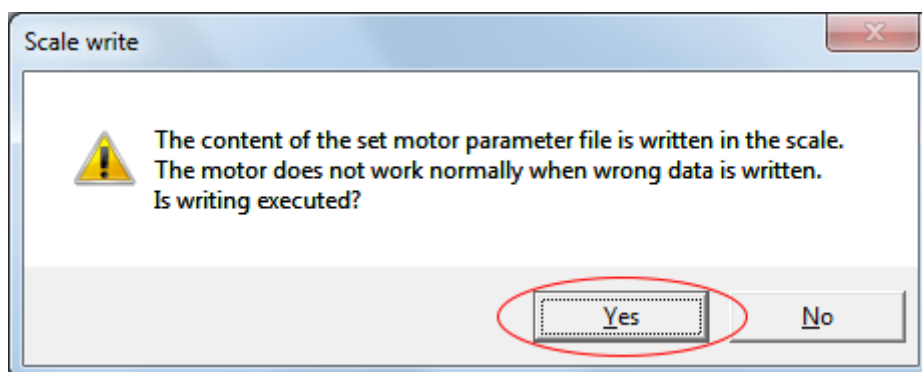


Fig. 105: Scale write - The content of the set motor parameter file is written in the scale

Click the **No** Button to cancel writing the motor parameters to the linear encoder.
If you click the **Yes** Button, writing the motor parameter scale will start.

10. Click the Complete Button.

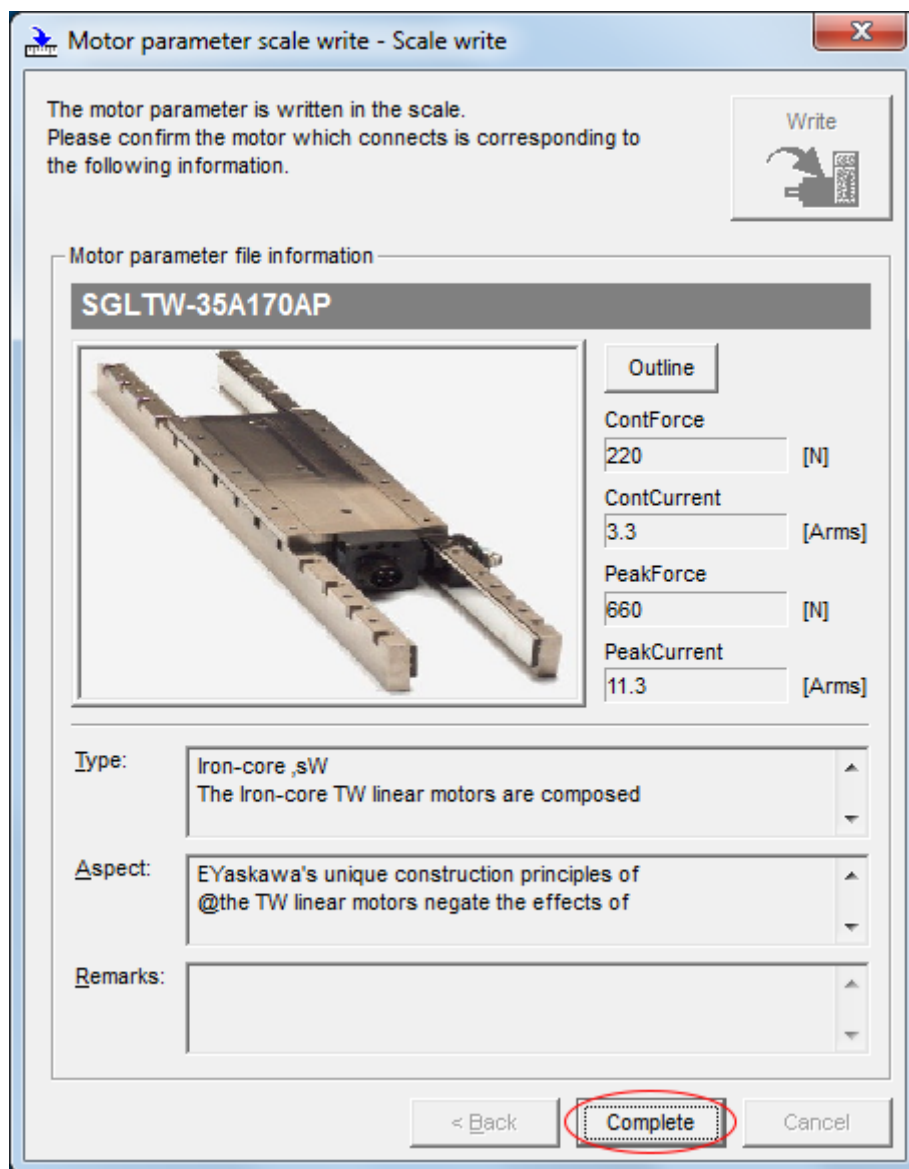


Fig. 106: Motor parameter scale write - Scale write - Complete

Selecting the Phase Sequence for a Linear Servomotor

11. Click the OK Button.

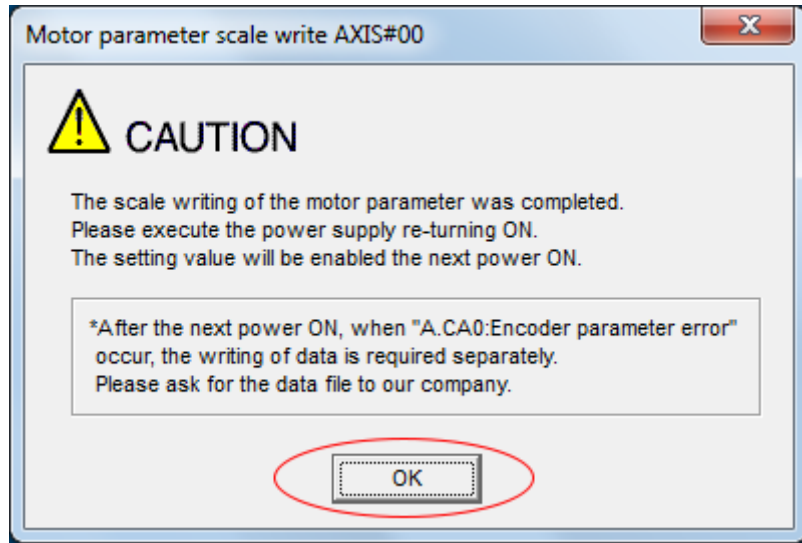


Fig. 107: Motor parameter scale write - Caution

12. Turn the power supply to the SERVOPACK OFF and ON again.

➔ This concludes the procedure to write the motor parameters.

Confirming If the Motor Parameters Have Been Written

After you write the motor parameters, you can use a monitor function to confirm that the motor parameters are in the encoder.

If the motor parameters have not been written, no information on the Servomotor will be displayed.

➔ [Chap. 10.2.1 'Monitoring Product Information' ...page 410](#)

6.8 Selecting the Phase Sequence for a Linear Servomotor

You must select the phase sequence of the Linear Servomotor so that the forward direction of the Linear Servomotor is the same as the encoder's count-up direction.

Before you set the Linear Servomotor phase sequence (Pn080 = n.□□X□), check the following items.

- Confirm that the signal from the linear encoder is being received normally.
- Make sure that the forward direction of the Linear Servomotor and the count-up direction of the linear encoder are in the same direction.



If you do not confirm the above items before you attempt to operate the Servomotor, the Servomotor may not operate or it may run out of control. Always confirm these items before you operate the motor.

Related Parameters

Parameter	Meaning	When Enabled	Classification
Pn080	n.□□0□ (default setting)	Set a phase-A lead as a phase sequence of U, V, and W.	After restart Setup

Parameter	Meaning	When Enabled	Classification
n.□□1□	Set a phase-B lead as a phase sequence of U, V, and W.		

Setting Procedure

Use the following procedure to select the phase sequence for a Linear Servomotor.

1. **1.** Set Pn000 to n.□□□0 (Set a phase-A lead as a phase sequence of U, V, and W).
This setting is to make following confirmation work easier to understand.

2. **2.** Select Monitor in the Menu Dialog Box.

➔ The Operation Pane will be displayed so that you can check the feedback pulse counter.

To check the feedback pulse counter with the Digital Operator, use Un00D (Feedback Pulse Counter).

3. **3.** Manually move the Moving Coil from one end to the other of the stroke and confirm that only the correct number of feedback pulses is returned.

If the correct number and only the correct number of pulses is returned, the signal is being received correctly from the linear encoder (➔ 'Example' ...page 152).



If the correct value is not displayed for the feedback pulse counter, the following conditions may exist. Check the situation and correct any problems.

– *The linear encoder pitch is not correct.*

If the scale pitch that is set in Pn282 does not agree with the actual scale pitch, the expected number of feedback pulses will not be returned. Check the specifications of the linear encoder.

– *The linear encoder is not adjusted properly.*

If the linear encoder is not adjusted properly, the output signal level from the linear encoder will drop and the correct number of pulses will not be counted. Check the adjustment of the linear encoder. Contact the manufacturer of the linear encoder for details.

– *There is a mistake in the wiring between the linear encoder and the Serial Converter Unit.*

If the wiring is not correct, the correct number of pulses will not be counted. Correct the wiring.

4. **4.** Manually move the Moving Coil in the direction of the cable and check the value of the feedback pulse counter in the Operation Panel to confirm that it is counting up.

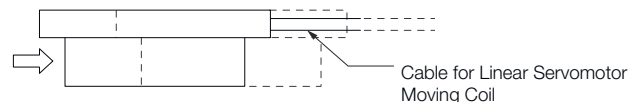



Fig. 108: Selecting the Phase Sequence for a Linear Servomotor

➔ Manually move the Moving Coil in the direction of the cable.

5. **5.** If the feedback pulse counter counts up, set a phase-A lead as a phase sequence of U, V, and W (Pn080 = n.□□0□).

If the feedback pulse counter counts down, set a phase-B lead as a phase sequence of U, V, and W (Pn080 = n.□□1□).

6. **6.** Turn the power supply to the SERVOPACK OFF and ON again.

7.  If necessary, return Pn000 = n.□□□X (Direction Selection) to its original setting.
 - ➔ This concludes the procedure to set the phase sequence of the Linear Servomotor.

Example

In this example, assume that a linear encoder with a scale pitch of 20 μm and a resolution of 256 is used. If you manually move the Moving Coil 1 cm in the count-up direction of the linear encoder, the number of feedback pulses would be as follows: $1 \text{ cm} / (20 \text{ μm} / 256) = 128,000$ pulses

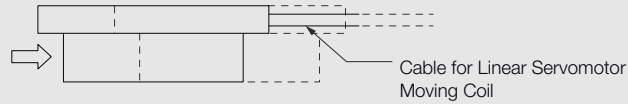


Fig. 109: Selecting the Phase Sequence for a Linear Servomotor

If there are 128,000 pulses on the feedback pulse counter after you manually move the Moving Coil in the direction of the cable, you have completed the confirmation.

Note: The actual monitor display will be offset by the error in the travel distance. There is no problem as long as the above value is close to the calculated value.

6.9 Polarity Sensor Setting

The polarity sensor detects the polarity of the Servomotor. You must set a parameter to specify whether the Linear Servomotor that is connected to the SERVOPACK has a polarity sensor. Specify whether there is a polarity sensor in Pn080 = n.□□□X (Polarity Sensor Selection).

If the Linear Servomotor has a polarity sensor, set Pn080 to n.□□□0 (Use polarity sensor) (default setting).

If the Linear Servomotor does not have a polarity sensor, set Pn080 to n.□□□1 (Do not use polarity sensor). Turn the power supply OFF and ON again to enable the new setting.

Parameter	Meaning	When Enabled	Classification
Pn080	n.□□□0 (default setting)	After restart	Setup
	n.□□□1		



If you set Pn080 to n.□□□0 (Use polarity sensor) and the Linear Servomotor that is connected to the SERVOPACK does not have a polarity sensor, an A.C21 alarm (Polarity Sensor Error) will occur when you turn the power supply OFF and ON again.

6.10 Polarity Detection

6.10.1 Overview

If you use a Linear Servomotor that does not have a polarity sensor, then you must detect the polarity.

Detecting the polarity means that the position of the electrical phase angle on the electrical angle coordinates of the Servomotor is detected. The SERVOPACK cannot control the Servomotor correctly unless it accurately knows the position of the electrical angle coordinate of the Servomotor.

The execution timing and execution method for polarity detection depend on the encoder specification as described in the following table.

Encoder Specification	Polarity Detection Execution Timing	Polarity Detection Execution Method
Incremental encoder	Each time the control power supply to the SERVOPACK is turned ON (Even after you execute polarity detection, the position of the polarity will be lost the next time the control power supply to the SERVOPACK is turned OFF.)	<ul style="list-style-type: none"> ■ Use the Servo ON command (Enable Operation command). ■ Use the polarity detection function of the SigmaWin+. ■ Execute the Fn080 (Polarity Detection) utility function from the Digital Operator.
Absolute encoder	Only for initial setup, or after the SERVOPACK, linear encoder, or Servomotor has been replaced (The results of polarity detection is stored in the absolute encoder, so the polarity position is not lost when the control power supply is turned OFF.)	<ul style="list-style-type: none"> ■ Use the polarity detection function of the SigmaWin+. ■ Execute the Fn080 (Polarity Detection) utility function from the Digital Operator.



If you use a Linear Servomotor that does not have a polarity sensor, you will not be able to turn ON the servo until polarity detection has been completed.

6.10.2 Restrictions

Assumed Conditions

The Servomotor will move when you execute polarity detection. The following conditions must be met before you start.

- It must be OK to move the Moving Coil about 10 mm. (If polarity detection fails, the Moving Coil may move approximately 5 cm. The amount of movement depends on conditions.)
- The linear encoder pitch must be 100 μm or less. (We recommend a pitch of 40 μm or less for an incremental encoder.)
- As much as possible, the motor must not be subjected to an imbalanced external force. (We recommend 5% or less of the rated force.)
- The mass ratio must be 50x or less.
- The axis must be horizontal.
- There must be friction equivalent to a few percent of the rated force applied to the guides. (Air sliders cannot be used.)

Preparations

Check the following settings before you execute polarity detection.

- Not using a polarity sensor must be specified (Pn080 = n.□□□1).
- The servo must be OFF.
- The main circuit power supply must be ON.
- There must be no hard wire base block (HWBB).
- There must be no alarms except for an A.C22 alarm (Phase Information Disagreement).
- The parameters must not be write prohibited. (This item applies only when using the SigmaWin+ or Digital Operator.)
- The test without a motor function must be disabled (Pn00C = n.□□□0).

- There must be no overtravel.
- If the motor parameters have been written or the origin of the absolute linear encoder has been set, the power supply to the SERVOPACK must be turned OFF and ON again after completion of the writing or setting operation.



- Power is supplied to the Servomotor during polarity detection. Be careful not to get an electric shock. Also, the Moving Coil of the Linear Servomotor may greatly move during detection. Do not approach the moving parts of the Servomotor.
- Polarity detection is affected by many factors. For example, polarity detection may fail if the mass ratio or friction is too large or the cable tension is too strong.

6.10.3 Using the Servo ON Command (Enable Operation Command) to Perform Polarity Detection

You can use the Servo ON command (Enable Operation command) to perform polarity detection only with an incremental linear encoder.

Polarity detection will start simultaneously with execution of the Servo ON command (Enable Operation command). As soon as polarity detection is completed, the /S-RDY will turn ON and the servo will change to ON status (*statusword = operation enabled*).

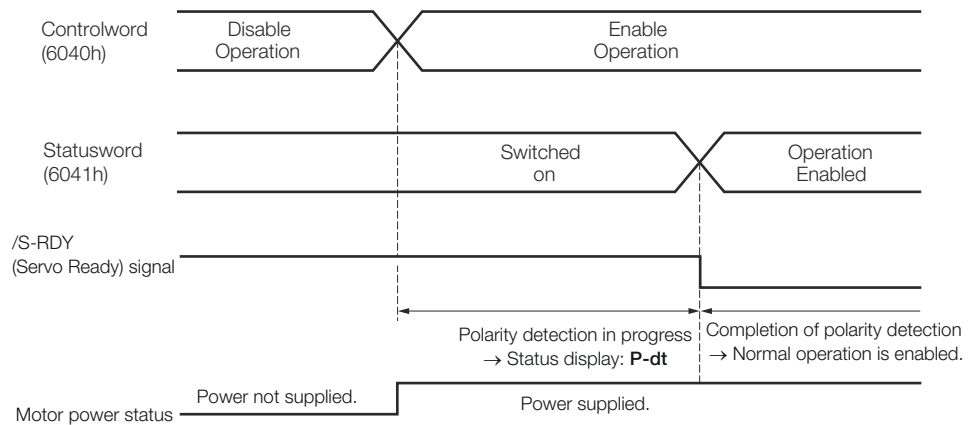


Fig. 110: Using the Servo ON Command (Enable Operation Command) to Perform Polarity Detection

6.10.4 Using a Tool Function to Perform Polarity Detection

Applicable Tools

The following table lists the tools that you can use to perform polarity detection and the applicable tool functions.

Tool	Function	Reference
Digital Operator	Fn080	Σ-7-Series Digital Operator Operating Manual (Manual No.: SIEP S800001 33)
SigmaWin+	Setup - Polarity Detection	↪ Chap. 6.10.4 'Using a Tool Function to Perform Polarity Detection' ...page 154

Operating Procedure

Use the following procedure to perform polarity detection.

1. Click the Servo Drive Button in the workspace of the Main Window of the SigmaWin+.

2. → Select Polarity Detection in the Menu Dialog Box.
 - ➔ The Polarity Detection Dialog Box will be displayed.
3. → Click the Continue Button.

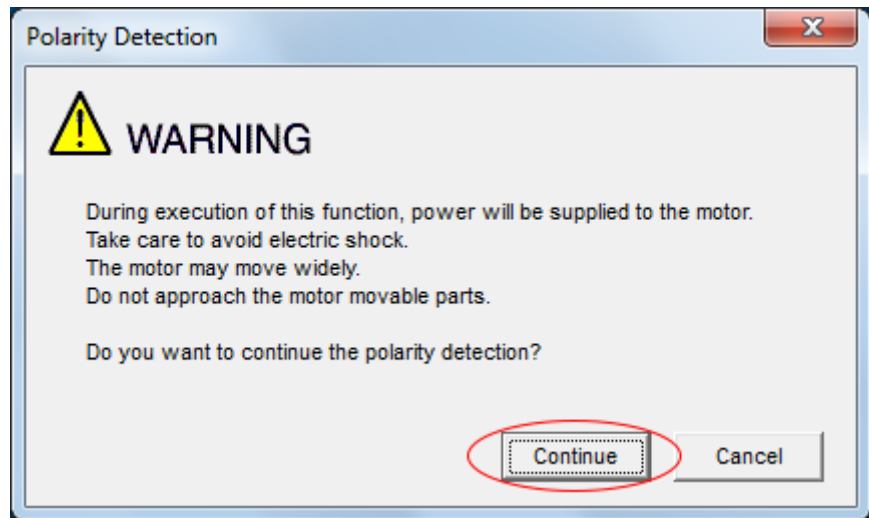


Fig. 111: Polarity Detection - Warning

- ➔ Click the Cancel Button to cancel polarity detection. The Main Window will return.
4. → Click the Start Button.
 - ➔ Polarity detection will be executed.

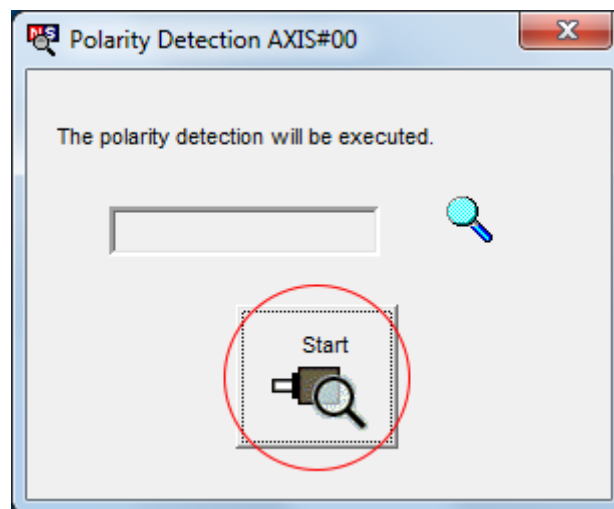


Fig. 112: Polarity Detection - Start

This concludes the polarity detection procedure.

6.11 Overtravel and Related Settings

6.11.1 Overview

Overtravel is a function of the SERVOPACK that forces the Servomotor to stop in response to a signal input from a limit switch that is activated when a moving part of the machine exceeds the safe range of movement.

The overtravel signals include the P-OT (Forward Drive Prohibit) and the N-OT (Reverse Drive Prohibit) signals.

You use the P-OT and N-OT signals to stop the machine by installing limit switches at the positions where you want to stop the machine that is operated by the Servomotor.

A SERVOPACK wiring example is provided below.

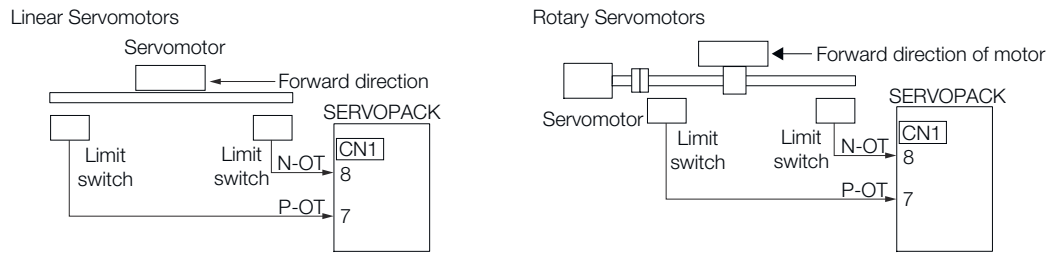


Fig. 113: Overtravel function - Wiring example

Using the overtravel function is not necessary for rotating applications such as rotary tables and conveyors. No wiring for overtravel input signals is required.

This section describes the parameters settings related to overtravel.



CAUTION

- To prevent accidents that may result from contact faults or disconnections, use normally closed limit switches. Do not change the default settings of the polarity of the overtravel signals (P-OT and N-OT).
- If you use a Servomotor for a vertical axis, the /BK (Brake) signal will remain ON (i.e., the brake will be released) when overtravel occurs. This may result in the workpiece falling when overtravel occurs. To prevent the workpiece from falling, the PROFINET option sets Pn001 to n.□□1□ during power-up. This places the Servomotor in a zero-clamped state when it stops.
- A base block state is entered after stopping for overtravel. This may cause the Servomotor to be pushed back by an external force on the load shaft. To prevent the Servomotor from being pushed back, the PROFINET option sets Pn001 to n.□□1□ during power-up. This places the Servomotor in a zero-clamped state when it stops.

6.11.2 Overtravel Signals

The overtravel signals include the P-OT (Forward Drive Prohibit) and the N-OT (Reverse Drive Prohibit) signals.

Type	Signal	Connector Pin No.	Signal Status	Meaning
Input	P-OT	CN1-7	ON	Forward drive is enabled (actual operation).
			OFF	Forward drive is prohibited (forward overtravel).
	N-OT	CN1-8	ON	Reverse drive is enabled (actual operation).
			OFF	Reverse drive is prohibited (reverse overtravel).

You can operate the Servomotor in the opposite direction during overtravel by inputting a reference.

6.11.3 Setting to Enable/Disable Overtravel

You can use Pn50A = n.X□□□ (P-OT (Forward Drive Prohibit) Signal Allocation) and Pn50B = n.□□□X (N-OT (Reverse Drive Prohibit) Signal Allocation) to enable and disable the overtravel function.

You do not need to wire the overtravel input signals if you are not going to use the overtravel function.

Parameter		Meaning	When Enabled	Classification
Pn50A	n.1□□□ (default setting)	The forward overtravel function is enabled and the P-OT (Forward Drive Prohibit) signal is input from CN1-7.	After restart	Setup
	n.8□□□	The forward overtravel function is disabled. Forward drive is always enabled.		
Pn50B	n.□□□2 (default setting)	The reverse overtravel function is enabled and the N-OT (Reverse Drive Prohibit) signal is input from CN1-8.		
	n.□□□8	The reverse overtravel function is disabled. Reverse drive is always enabled.		

You can allocate the P-OT and N-OT signals to other connector pins. Refer to the following section for details.

→ [Chap. 7.2.2 'Input Signal Allocations' ...page 189](#)

6.11.4 Motor Stopping Method for Overtravel

You can set the stopping method of the Servomotor when overtravel occurs in Pn001 = n.□□XX (Motor Stopping Method for Servo OFF and Group 1 Alarms, Overtravel Stopping Method).

Parameter		Motor Stopping Method*	Status after Stopping	When Enabled	Classification
Pn001	n.□□1□	Deceleration according to setting of Pn406	Zero clamp	After restart	Setup

* You cannot decelerate a Servomotor to a stop during torque control. For torque control, the Servomotor will be stopped with the dynamic braking or coast to a stop (according to the setting of Pn001 = n.□□□X (Motor Stopping Method for Servo OFF and Group 1 Alarms)), and then the Servomotor will enter a coasting state.

Refer to the following section for information on stopping methods other than those for overtravel.

→ [Chap. 6.13.2 'Stopping Method for Servo OFF' ...page 168](#)

Stopping the Servomotor by Setting Emergency Stop Torque

To stop the Servomotor by setting emergency stop torque, set Pn406 (Emergency Stop Torque).

If Pn001 = n.□□X□ is set to 1 or 2, the Servomotor will be decelerated to a stop using the torque set in Pn406 as the maximum torque.

The default setting is 800%. This setting is large enough to allow you to operate the Servomotor at the maximum torque. However, the maximum emergency stop torque that you can actually use is the maximum torque of the Servomotor.

Emergency Stop Torque

	Setting Range	Setting Unit	Default Setting	When Enabled	Classification
Pn406	0 to 800	1%*	800	Immediately	Setup

(applies to Speed Control and Position Control)

* Set a percentage of the motor rated torque.

Stopping the Servomotor by Setting the Deceleration Time

To specify the Servomotor deceleration time and use it to stop the Servomotor, set Pn30A (Deceleration Time for Servo OFF and Forced Stops).

Deceleration Time for Servo OFF and Forced Stops

	Setting Range	Setting Unit	Default Setting	When Enabled	Classification
Pn30A	0 to 10,000	1 ms	0	Immediately	Setup

(applies to Speed Control and Position Control)

If you set Pn30A to 0, the Servomotor will be stopped with a zero speed.

The deceleration time that you set in Pn30A is the time to decelerate the motor from the maximum motor speed.

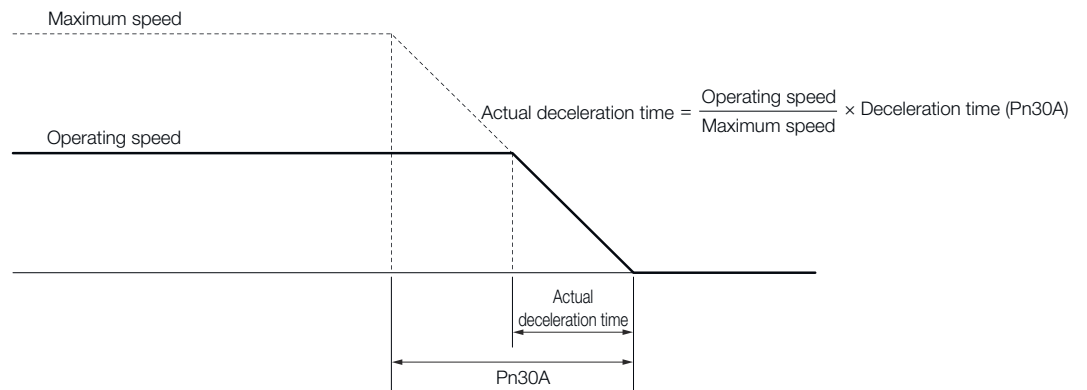


Fig. 114: Stopping the Servomotor by Setting the Deceleration Time

6.11.5 Overtravel Warnings

You can set the system to detect an A.9A0 warning (Overtravel) if overtravel occurs while the servo is ON. This allows the SERVOPACK to notify the host controller with a warning even when the overtravel signal is input only momentarily. An alarm occurs only if overtravel occurs while the servo is ON. An overtravel warning will not be detected when the servo is OFF, even if overtravel occurs.



- The occurrence of an A.9A0 warning will not stop the motor or have any effect on host controller motion operations. The next step (e.g., the next motion or command) can be executed even if an overtravel warning exists.
However, depending on the processing specifications and programming for warnings in the host controller, operation may be affected when an overtravel warning occurs (e.g., motion may stop or not stop). Confirm the specifications and programming in the host controller.
- When overtravel occurs, the SERVOPACK will perform stop processing for overtravel. Therefore, when an A.9A0 warning occurs, the Servomotor may not reach the target position specified by the host controller. Check the feedback position to make sure that the axis is stopped at a safe position.

The following parameter is set for this function.

Parameter	Meaning	When Enabled	Classification
Pn00D	n.0□□□ (default setting)	Immediately	Setup
	n.1□□□		

A timing chart for warning detection is provided below.

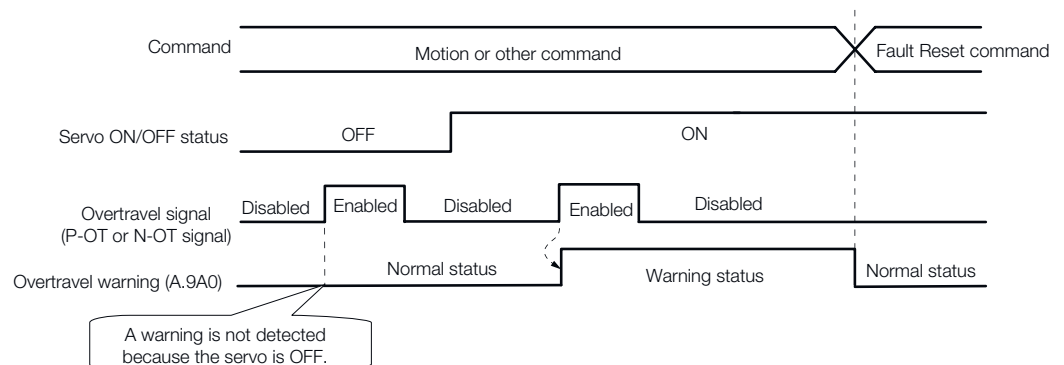


Fig. 115: Overtravel Warnings



- Warnings are detected for overtravel in the same direction as the reference.
- Warnings are not detected for overtravel in the opposite direction from the reference. Example: A warning will not be output for a forward reference even if the N-OT signal turns ON.
- A warning can be detected in either the forward or reverse direction if there is no reference.
- A warning will not be detected when the servo is turned ON even if overtravel status exists.
- You can use the ALM_CLR (Clear Alarms and Warnings) command to clear the warning regardless of the servo ON/OFF status and overtravel signal status.
- If you clear the warning with the Fault Reset command during overtravel status, a warning will not be detected again until the overtravel status is left
- An overtravel warning will be detected even when the software limit has been detected.

6.11.6 Overtravel Release Method Selection

You can set Pn022 = n.□□□X (Overtravel Release Method Selection) to release overtravel. *Internal limit active* (ZSW1 bit 11 in *PROFIdrive Position Mode*, ZSW1 bit 15 in all other cases) changes to 1 during overtravel. The motor will not be driven if there is overtravel in the same direction as the reference.

The PROFINET implementation corresponds to the described setting Pn022 = n.□□□1.

Parameter	Meaning	When Enabled	Classification
Pn022	n.□□□0 (default setting)	After restart	Setup
	n.□□□1		

* Here, “separated” means a position that is further in the positive direction than the P-OT signal or a position that is further in the negative direction than the N-OT signal.

When Pn022 Is Set to n.□□□0

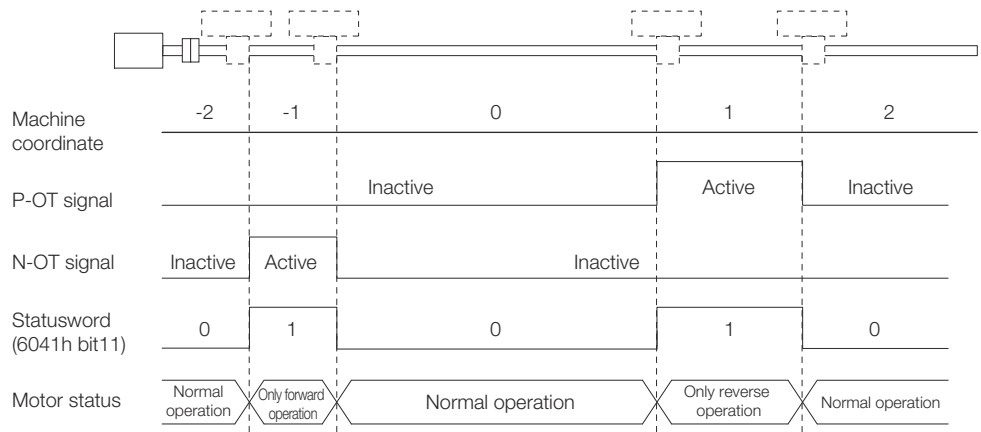


Fig. 116: Overtravel Release Method n.□□□0

When Pn022 Is Set to n.□□□1

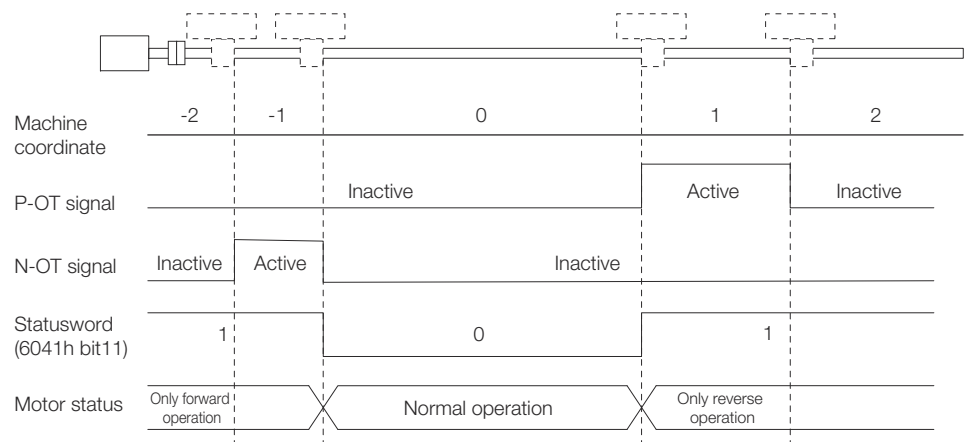


Fig. 117: Overtravel Release Method n.□□□1

6.11.7 Overtravel Status

If an overtravel signal is input, *Internal limit active* in *statusword* (6041h) will change to 1 and the Servomotor will be stopped according to the overtravel stopping method set in Pn001. When the overtravel signal is reset, the status changes to 0.



In PROFIdrive Position Mode, Internal limit active is ZSW1 bit 11. In all other cases it is ZSW1 bit 15.

6.11.8 Overtravel Operation by Mode

Operation Mode	Operation
PROFIdrive Profile Position mode	<ul style="list-style-type: none"> ■ If an overtravel signal is input, the positioning operation to the current target position will be canceled and, after the motor stops, <i>target reached</i> in <i>statusword</i> will be reset. ■ A positioning operation (return operation) is started only when a movement reference to a target position in the opposite direction from the overtravel signal is specified in the current Position Actual Value (e.g., a negative movement reference if the P-OT signal is input).
PROFIdrive Profile Velocity mode	<ul style="list-style-type: none"> ■ During overtravel, the motor is operated only when a speed in the direction opposite from the overtravel signal is specified (e.g., a negative target speed when the P-OT signal is input).
Profile Torque Mode	<ul style="list-style-type: none"> ■ During overtravel, torque is applied only when a torque in the direction opposite from the overtravel signal is specified (e.g., a negative torque when the P-OT signal is input).

6.12 Holding Brake

6.12.1 Overview

A holding brake is used to hold the position of the moving part of the machine when the SERVOPACK is turned OFF so that moving part does not move due to gravity or an external force. You can use the brake that is built into a Servomotor with a Brake, or you can provide one on the machine.

The holding brake is used in the following cases.

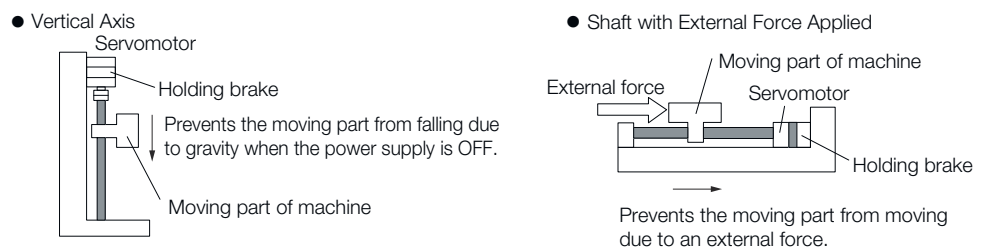


Fig. 118: Holding Brake - Use



The brake built into a Servomotor with a Brake is a de-energization brake. It is used only to hold the Servomotor and cannot be used for braking. Use the holding brake only to hold a Servomotor that is already stopped.

6.12.2 Brake Operating Sequence

You must consider the brake release delay time and the brake operation delay time to determine the brake operation timing, as described below.



– **Brake Release Delay Time**

The time from when the /BK (Brake) signal is turned ON until the brake is actually released.

– **Brake Operation Delay Time**

The time from when the /BK (Brake) signal is turned OFF until the brake actually operates.

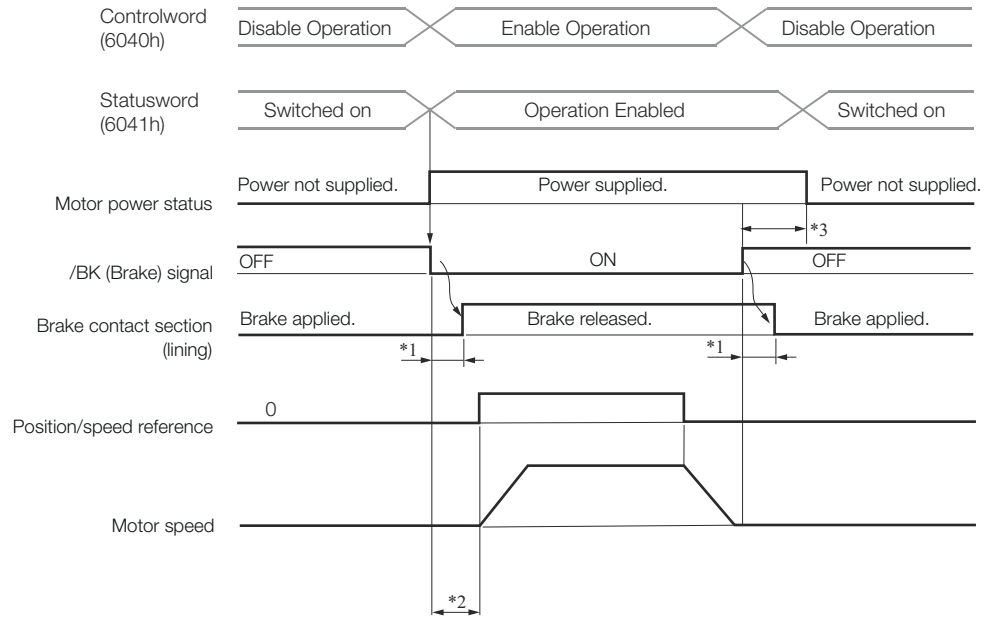


Fig. 119: Brake Operating Sequence

*1. Rotary Servomotors: The brake delay times for Servomotors with Holding Brakes are given in the following table. The operation delay times in the following table are examples for when the power supply is switched on the DC side. You must evaluate the actual brake delay times on the actual equipment before using the application.

Model	Voltage	Time Required to Release Brake [ms]	Time Required to Brake [ms]	
SGM7M-A1 to -A3	24 VDC	60	100	
SGM7J-A5 to -04				
SGM7J-06 and -08		80		
SGM7A-A5 to -04		60		
SGM7A-06 to -10		80		
SGM7A-15 to -25		170	80	
SGM7A-30 to -50		100		
SGM7P-01		20	100	
SGM7P-02 and -04		40		
SGM7P-08 and -15		20		
SGM7G-03 to -20		100	80	
SGM7G-30 to -44		170	100	
SGM7G-55 to -1A			80	
SGM7G-1E			250	

Linear Servomotors: The brake delay times depend on the brake that you use. Set the parameters related to /BK signal output timing according to the delay times for the brake that you will actually use.

*2. Before you output a reference from the host controller to the SERVOPACK, wait for at least 50 ms plus the brake release delay time after you send the SV_ON command.

*3. Use the following parameters to set the timing of when the brake will operate and when the servo will be turned OFF

- Rotary Servomotors: Pn506 (Brake Reference-Servo OFF Delay Time), Pn507 (Brake Reference Output Speed Level), and Pn508 (Servo OFF-Brake Reference Waiting Time)
- Linear Servomotors: Pn506 (Brake Reference-Servo OFF Delay Time), Pn508 (Servo OFF-Brake Reference Waiting Time), and Pn583 (Brake Reference Output Speed Level)

Connection Examples

Refer to the following section for information on brake wiring.

➔ [Chap. 5.5.4 'Wiring the SERVOPACK to the Holding Brake' ...page 112](#)

6.12.3 /BK (Brake) Signal

The following settings are for the output signal that controls the brake. You can change the connector pin that is allocated. For details, refer to ➔ ['Allocating the /BK \(Brake\) Signal' ...page 164](#).

The /BK signal is turned OFF (to operate the brake) when the servo is turned OFF or when an alarm is detected. You can adjust the timing of brake operation (i.e., the timing of turning OFF the /BK signal) with the servo OFF delay time (Pn506).

Type	Signal	Connector Pin No.	Signal Status	Meaning
Output	/BK	CN1-1, CN1-2	ON (closed)	Releases the brake.
			OFF (open)	Activates the brake.



The /BK signal will remain ON during overtravel. The brake will not be applied.

Allocating the /BK (Brake) Signal

Set the allocation for the /BK signal in Pn50F = n.□X□□ (/BK (Brake Output) Signal Allocation).

Parameter		Connector Pin No.		Meaning	When Enabled	Classification
		+ Pin	- Pin			
Pn50F	n.□0□□	-	-	The /BK signal is not used.	After restart	Setup
	n.□1□□ (default setting)	CN1-1	CN1-2	The /BK signal is output from CN1-1 and CN1-2.		
	n.□2□□	CN1-2 3	CN1-2 4	The /BK signal is output from CN1-23 and CN1-24.		
	n.□3□□	CN1-2 5	CN1-2 6	The /BK signal is output from CN1-25 and CN1-26.		



If you allocate more than one signal to the same output connector pin, a logical OR of the signals is output. Allocate the /BK signal to its own output connector pin, i.e., do not use the same output terminal for another signal.

For example, never allocate the /TGON (Rotation Detection) signal and /BK signal to the same output connector pin. If you did so, the /TGON signal would be turned ON by the falling speed on a vertical axis, and the brake would not operate.

6.12.4 Output Timing of /BK (Brake) Signal When the Servomotor Is Stopped

When the Servomotor is stopped, the /BK signal turns OFF as soon as the Servo OFF command (Disable Operation command) is received. Use the servo OFF delay time (Pn506) to change the timing to turn OFF power supply to the motor after the Servo OFF command (Disable Operation command) is input.

Brake Reference-Servo OFF Delay Time

	Setting Range	Setting Unit	Default Setting	When Enabled	Classification
Pn506	0 to 50	10 ms	0	Immediately	Setup

(applies to Speed Control, Position Control and Torque Control)

- When the Servomotor is used to control a vertical axis, the machine moving part may move slightly due to gravity or an external force. You can eliminate this slight motion by setting the servo OFF delay time (Pn506) so that power supply to the motor is stopped after the brake is applied.
- This parameter sets the timing of stopping power supply to the Servomotor while the Servomotor is stopped.

Holding Brake > Output Timing of /BK (Brake) Signal When the Servomotor Is Operating

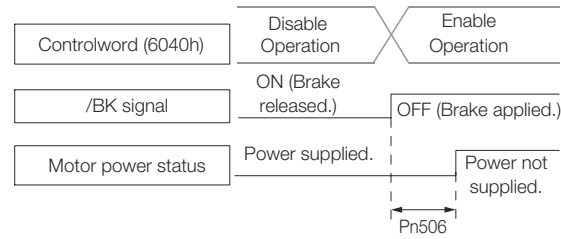


Fig. 120: Brake Reference-Servo OFF Delay Time



Power supply to the Servomotor will be stopped immediately when an alarm occurs, regardless of the setting of this parameter. The machine moving part may move due to gravity or an external force before the brake is applied.

6.12.5 Output Timing of /BK (Brake) Signal When the Servomotor Is Operating

If an alarm occurs while the Servomotor is operating, the Servomotor will start stopping and the /BK signal will be turned OFF. You can adjust the timing of /BK signal output by setting the brake reference output speed level (Rotary Servomotors: Pn507, Linear Servomotors: Pn583) and the servo OFF-brake reference waiting time (Pn508).



If zero-speed stopping is set as the stopping method for alarms, the setting of Pn506 (Brake Reference- Servo OFF Delay Time) is used after the motor stops.

Rotary Servomotors

Brake Reference Output Speed Level

	Setting Range	Setting Unit	Default Setting	When Enabled	Classification
Pn507	0 to 10,000	1 min ⁻¹	100	Immediately	Setup

(applies to Speed Control, Position Control and Torque Control)

Servo OFF-Brake Reference Waiting Time

	Setting Range	Setting Unit	Default Setting	When Enabled	Classification
Pn508	10 to 100	10 ms	50	Immediately	Setup

(applies to Speed Control, Position Control and Torque Control)

Linear Servomotors

Brake Reference Output Speed Level

	Setting Range	Setting Unit	Default Setting	When Enabled	Classification
Pn583	0 to 10,000	1 mm/s	10	Immediately	Setup

(applies to Speed Control, Position Control and Force Control)

Servo OFF-Brake Reference Waiting Time

	Setting Range	Setting Unit	Default Setting	When Enabled	Classification
Pn508	10 to 100	10 ms	50	Immediately	Setup

(applies to Speed Control, Position Control and Force Control)

The brake operates when either of the following conditions is satisfied:

- When the Motor Speed Goes below the Level Set in Pn507 for a Rotary Servomotor or in Pn583 for a Linear Servomotor after the Power Supply to the Motor Is Stopped

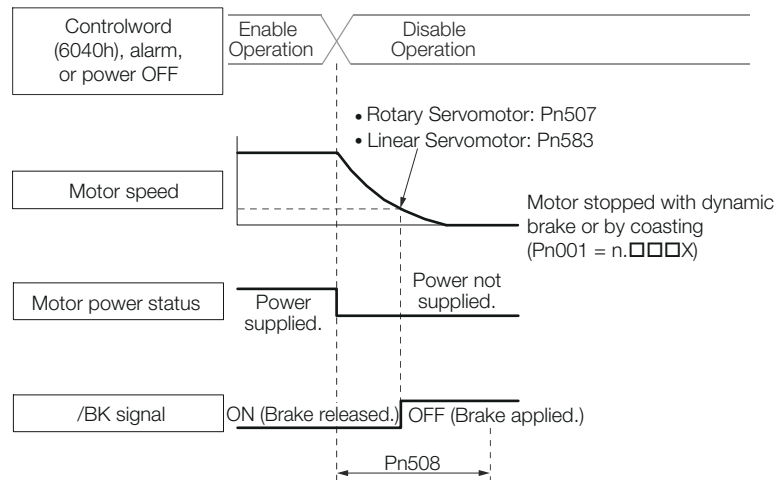


Fig. 121: Brake Reference Output Speed Level

- When the Time Set In Pn508 Elapses after the Power Supply to the Motor Is Stopped

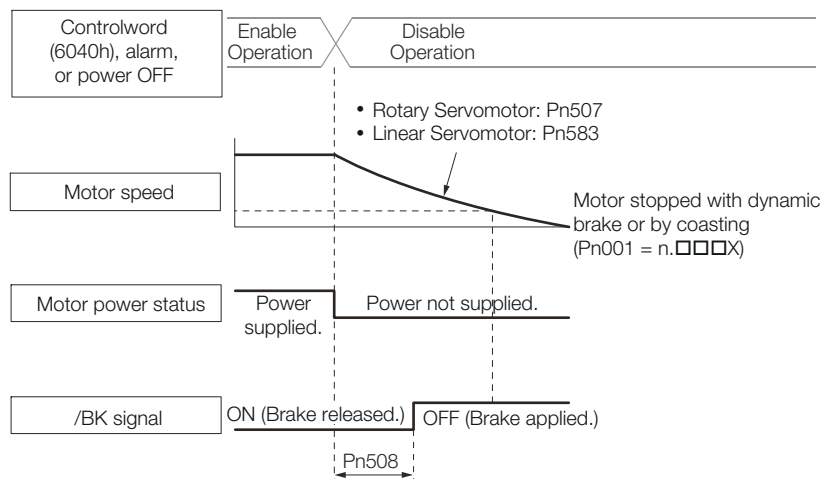


Fig. 122: Servo OFF-Brake Reference Waiting Time



The Servomotor will be limited to its maximum speed even if the brake reference output speed level (Rotary Servomotor: Pn507, Linear Servomotor: Pn583) is higher than the maximum speed.

6.13 Motor Stopping Methods for Servo OFF and Alarms

6.13.1 Overview

You can use the following methods to stop the Servomotor when the servo is turned OFF or an alarm occurs.

There are the following four stopping methods.

Motor Stopping Method	Meaning
Stopping by Applying the Dynamic Brake	The electric circuits are internally connected to stop the Servomotor quickly.
Coasting to a Stop	The motor stops naturally due to friction during operation.
Zero-speed Stopping	The speed reference is set to 0 to stop the Servomotor quickly.
Decelerating to a Stop	Emergency stop torque is used to decelerate the motor to a stop.

There are the following three conditions after stopping.

Status after Stopping	Meaning
Dynamic Brake Applied	The electric circuits are internally connected to hold the Servomotor.
Coasting	The SERVOPACK does not control the Servomotor. (The machine will move in response to a force from the load.)
Zero Clamping	A position loop is created and the Servomotor remains stopped at a position reference of 0. (The current stop position is held.)



- *The dynamic brake is used for emergency stops. The dynamic brake circuit will operate frequently if the power supply is turned ON and OFF or the servo is turned ON and OFF while a reference input is applied to start and stop the Servomotor. This may result in deterioration of the internal elements in the SERVOPACK. Use speed input references or position references to start and stop the Servomotor.*
- *If you turn OFF the main circuit power supply or control power supply during operation before you turn OFF the servo, the Servomotor stopping method depends on the SERVOPACK model as shown in the following table.*

Servomotor Stopping Method

Condition	Servomotor Stopping Method	
		SGD7S-R70A, -1R6A, -2R8A, -3R8A, -5R5A, -7R6A, -120A, -180A, -200A, -R70F, -R90F, -2R1F, or -2R8F
Main circuit power supply turned OFF before turning OFF the servo	Stopping with dynamic brake	
Control power supply turned OFF before turning OFF the servo	Stopping with dynamic brake	Coasting to a stop

- To minimize the coasting distance of the Servomotor to come to a stop when an alarm occurs, zero-speed stopping is the default method for alarms to which it is applicable. However, depending on the application, stopping with the dynamic brake may be more suitable than zero-speed stopping.

For example, when coupling two shafts (twin-drive operation), machine damage may occur if a zero-speed stopping alarm occurs for one of the coupled shafts and the other shaft stops with a dynamic brake. In such cases, change the stopping method to the dynamic brake.

6.13.2 Stopping Method for Servo OFF

Set the stopping method for when the servo is turned OFF in Pn001 = n.□□□X (Motor Stopping Method for Servo OFF and Group 1 Alarms).

Parameter		Servomotor Stopping Method	Status after Servomotor Stops	When Enabled	Classification
Pn001	n.□□□0 (default setting)	Dynamic brake *	Dynamic brake *	After restart	Setup
	n.□□□1		Coasting		
	n.□□□2	Coasting	Coasting		

* The Servomotor will coast to a stop when the SERVOPACK is not equipped with a built-in Dynamic Brake Resistor or an External Dynamic Brake Resistor is not connected.



If Pn001 is set to n.□□□0 (Stop the motor by applying the dynamic brake) and the Servomotor is stopped or operates at a low speed, braking force may not be generated, just like it is not generated for coasting to a stop.

6.13.3 Servomotor Stopping Method for Alarms

There are three types of alarms, group 1 (Gr. 1) alarms, group 2 (Gr. 2) alarms and "PROFINET module" alarms. A different parameter is used to set the stopping method for alarms for each alarm type.

Refer to the following section to see which alarms are in group 1 and which are in group 2.

➔ [Chap. 16.4.2.1 'List of Alarms' ...page 552](#)

Motor Stopping Method for Group 1 Alarms

When a group 1 alarm occurs, the Servomotor will stop according to the setting of Pn001 = n.□□□X. The default setting is to stop by applying the dynamic brake.

Refer to the following section for details.

➔ [Chap. 6.13.2 'Stopping Method for Servo OFF' ...page 168](#)

Motor Stopping Method for Group 2 Alarms

When a group 2 alarm occurs, the Servomotor will stop according to the settings of the following three parameters. The default setting is for zero clamping.

- Pn001 = n.□□□X (Motor Stopping Method for Servo OFF and Group 1 Alarms)
- Pn00A = n.□□□X (Motor Stopping Method for Group 2 Alarms)
- Pn00B = n.□□X□ (Motor Stopping Method for Group 2 Alarms)

However, during torque control, the group 1 stopping method is always used. If you set Pn00B to n.□□1□ (Apply the dynamic brake or coast the Servomotor to a stop), you can use the same stopping method as group 1. If you are coordinating a number of Servomotors, you can use this stopping method to prevent machine damage that may result because of differences in the stopping method.

The following table shows the combinations of the parameter settings and the resulting stopping methods.

Parameter			Servomotor Stopping Method	Status after Servomotor Stops	When Enabled	Classification
Pn00B	Pn00A	Pn001				
n.□□0□ (default setting)	–	n.□□□0 (default setting)	Zero-speed stopping	Dynamic brake	After restart	Setup
		n.□□□1		Coasting		
		n.□□□2				
n.□□1□	–	n.□□□0 (default setting)	Dynamic brake	Dynamic brake		
		n.□□□1		Coasting		
		n.□□□2	Coasting			
n.□□2□	n.□□□0	n.□□□0 (default setting)	Dynamic brake	Dynamic brake		
		n.□□□1		Coasting		
		n.□□□2		Coasting		
	n.□□□1 (default setting)	n.□□□0 (default setting)	Motor is decelerated using the torque set in Pn406 as the maximum torque.	Dynamic brake		
		n.□□□1		Coasting		
		n.□□□2				
	n.□□□2	n.□□□0 (default setting)	Motor is decelerated according to setting of Pn30A.	Coasting		
		n.□□□1				
		n.□□□2				
	n.□□□3	n.□□□0 (default setting)	Motor is decelerated according to setting of Pn30A.	Dynamic brake		
		n.□□□1		Coasting		
		n.□□□2				
	n.□□□4	n.□□□0 (default setting)	Motor is decelerated according to setting of Pn30A.	Coasting		
		n.□□□1				
		n.□□□2				



- The setting of Pn00A is ignored if Pn00B is set to n.□□0□ or n.□□1□.
- The setting of Pn00A = n.□□□X is enabled for position control and speed control. During torque control, the setting of Pn00A = n.□□□X will be ignored and only the setting of Pn001 = n.□□□X will be used.
- Refer to the following section for details on Pn406 (Emergency Stop Torque).
[↔ Chap. 6.11.4 'Motor Stopping Method for Overtravel' ...page 157](#)
- Refer to the following section for details on Pn30A (Deceleration Time for Servo OFF and Forced Stops).
[↔ Chap. 6.11.4 'Motor Stopping Method for Overtravel' ...page 157](#)

Servomotor Stopping Method for PROFINET Alarms

When a PROFINET alarm occurs, the Servomotor will stop according to the setting of object Fault Reaction Option Code (605Eh). The default setting is to 2, i.e. to slow down on quick stop ramp and turn the servo off. Refer to the following section for details.

➔ 'Fault Reaction Option Code' ...page 519

6.14 Motor Overload Detection Level

6.14.1 Overview

The motor overload detection level is the threshold used to detect overload alarms and overload warnings when the Servomotor is subjected to a continuous load that exceeds the Servomotor ratings.

It is designed to prevent Servomotor overheating.

You can change the detection timing for A.910 warnings (Overload) and A.720 alarms (Continuous Overload). You cannot change the detection level for A.710 alarms (Instantaneous Overload).

6.14.2 Detection Timing for Overload Warnings (A.910)

With the default setting for overload warnings, an overload warning is detected in 20% of the time required to detect an overload alarm. You can change the time required to detect an overload warning by changing the setting of the overload warning level (Pn52B). You can increase safety by using overload warning detection as an overload protection function matched to the system.

The following graph shows an example of the detection of overload warnings when the overload warning level (Pn52B) is changed from 20% to 50%. An overload warning is detected in half of the time required to detect an overload alarm.

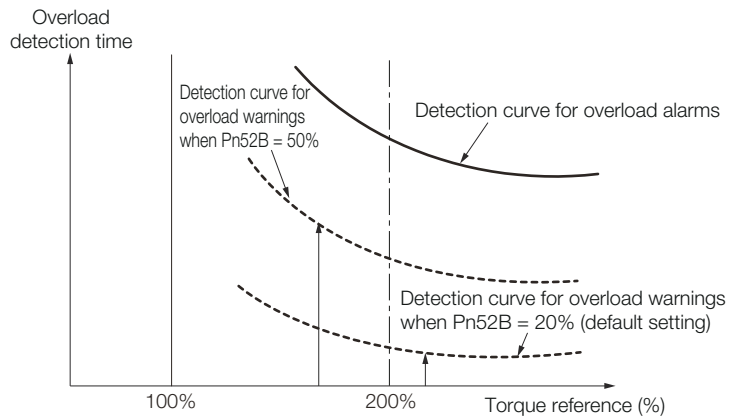


Fig. 123: Detection Timing for Overload Warnings (A.910)

Overload Warning Level

	Setting Range	Setting Unit	Default Setting	When Enabled	Classification
Pn52B	1 to 100	1%	20	Immediately	Setup

(applies to Speed Control, Position Control and Torque Control)

6.14.3 Detection Timing for Overload Alarms (A.720)

If Servomotor heat dissipation is insufficient (e.g., if the heat sink is too small), you can lower the overload alarm detection level to help prevent overheating.

To reduce the overload alarm detection level, change the setting of Pn52C (Base Current Derating at Motor Overload Detection).

Base Current Derating at Motor Overload Detection

	Setting Range	Setting Unit	Default Setting	When Enabled	Classification
Pn52C	10 to 100	1%	100	After restart	Setup

(applies to Speed Control, Position Control and Torque Control)

An A.720 alarm (Continuous Overload) can be detected earlier to protect the Servomotor from overloading.

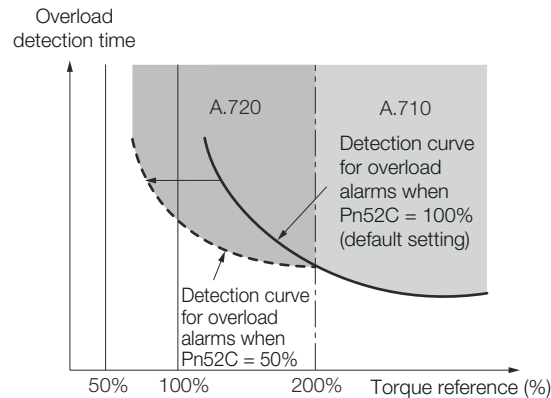


Fig. 124: Detection Timing for Overload Alarms (A.720)



The gray areas in the above graph show where A.710 and A.720 alarms occur.

Refer to the relevant manual given below for a diagram that shows the relationships between the Servomotor heat dissipation conditions (heat sink size, surrounding air temperature, and derating). You can protect the Servomotor from overloads more effectively by setting this derating value in Pn52C.

Name	Manual number
Σ-7-Series Rotary Servomotor Product Manual	SIEP S800001 36
Σ-7-Series Linear Servomotor Product Manual	SIEP S800001 37
Σ-7-Series Direct Drive Servomotor Product Manual	SIEP S800001 38

6.15 Setting Unit Systems

6.15.1 Overview

You can set the SERVOPACK reference units with PROFINET communications. You can set the following three reference units with PROFINET communications.

- Position reference unit
- Speed reference unit
- Acceleration reference unit

The setting procedures are given below.

6.15.2 Setting the Position Reference Unit

Set the position reference unit in *Position User Unit* (2301h). The position reference unit setting will be used for the electronic gear ratio setting.



- Set the position reference unit within the following range.
 $1/4,096 < \text{Numerator/Denominator} < 65,536$
 If the setting range is exceeded, an A.A20 alarm (Parameter Setting Error) will occur.

Index	Subindex	Name	Data Type	Access	PDO Mappings	Value	Saving to EEPROM
2301h	1	Numerator	UDINT	RW	No	$1 \leq \text{Value range} \leq 2^{31}-1$ (default: 1)	Yes
	2	Denominator	UDINT	RW	No	$1 \leq \text{Value range} \leq 2^{31}-1$ (default: 1)	Yes



Refer to the following section for information on *Position User Unit* (2301h).
 → [Chap. 15.5 'Manufacturer Specific Objects' ...page 507](#)

The minimum unit of the position data that is used to move a load is called the reference unit. The reference unit is used to give travel amounts, not in pulses, but rather in distances or other physical units (such as μm or $^\circ$) that are easier to understand.

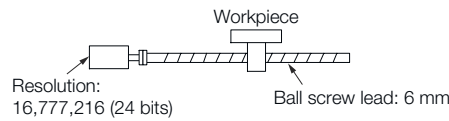
The electronic gear is used to convert the travel distances that are specified in reference units to pulses, which are required for actual movements.

With the electronic gear, one reference unit is equal to the workpiece travel distance per reference pulse input to the SERVOPACK. In other words, if you use the SERVOPACK's electronic gear, pulses can be read as reference units.

The difference between using and not using the electronic gear is shown below.

Rotary Servomotors

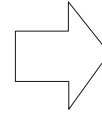
In this example, the following machine configuration is used to move the workpiece 10 mm.



When the Electronic Gear Is Not Used

To move a workpiece 10 mm:
1 - Calculate the number of revolutions.
The Servomotor will move 6 mm for each revolution, so 10/6 revolutions are required to move 10 mm.
2 - Calculate the required number of reference pulses.
One revolution is 1,048,576 pulses, therefore $10/6 \times 1,048,576 = 1,747,626.66$ pulses.
3 - Input 1,747,627 pulses as the reference.

Calculating the number of reference pulses for each reference is troublesome.



When the Electronic Gear Is Used

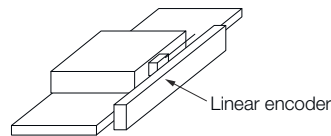
If you use reference units to move the workpiece when one reference unit is set to 1 μm , the travel distance is 1 μm per pulse.
To move the workpiece 10 mm (10,000 μm), $10,000 \div 1 = 10,000$ pulses, so 10,000 pulses would be input.

Calculating the number of reference pulses for each reference is not necessary.

Fig. 125: Setting the Position Reference Unit - Rotary Servomotor Example

Linear Servomotors

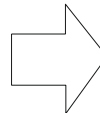
In this example, the following machine configuration is used to move the load 10 mm. We'll assume that the resolution of the Serial Converter Unit is 256 and that the linear encoder pitch is 20 μm .



When the Electronic Gear Is Not Used

To move the load 10 mm:
 $10 \times 1000 \div 20 \times 256 = 128,000$ pulses, so 128,000 pulses are input as the reference.

Calculating the number of reference pulses for each reference is troublesome.



When the Electronic Gear Is Used

To use reference units to move the load 10 mm:
If we set the reference unit to 1 μm , the travel distance is 1 μm per pulse. To move the load 10 mm (10,000 μm), $10,000/1 = 10,000$ pulses, so 10,000 pulses would be input as the reference.

Calculating the number of reference pulses for each reference is not necessary.

Fig. 126: Setting the Position Reference Unit - Linear Servomotor Example

Calculating the Settings for the Electronic Gear Ratio

Rotary Servomotors

If the gear ratio between the Servomotor shaft and the load is given as n/m , where n is the number of load rotations for m Servomotor shaft rotations, the settings for the electronic gear ratio can be calculated as follows:

$$\text{Electronic gear ratio } \frac{B}{A} = \frac{\text{Numerator}}{\text{Denominator}} = \frac{\text{Encoder resolution}}{\text{Travel distance per load shaft revolution (reference units)}} \times \frac{m}{n}$$

Fig. 127: Calculating the Settings for the Electronic Gear Ratio - Rotary Servomotors Formula

Encoder Resolution

You can check the encoder resolution in the Servomotor model number.

Setting Unit Systems > Setting the Position Reference Unit

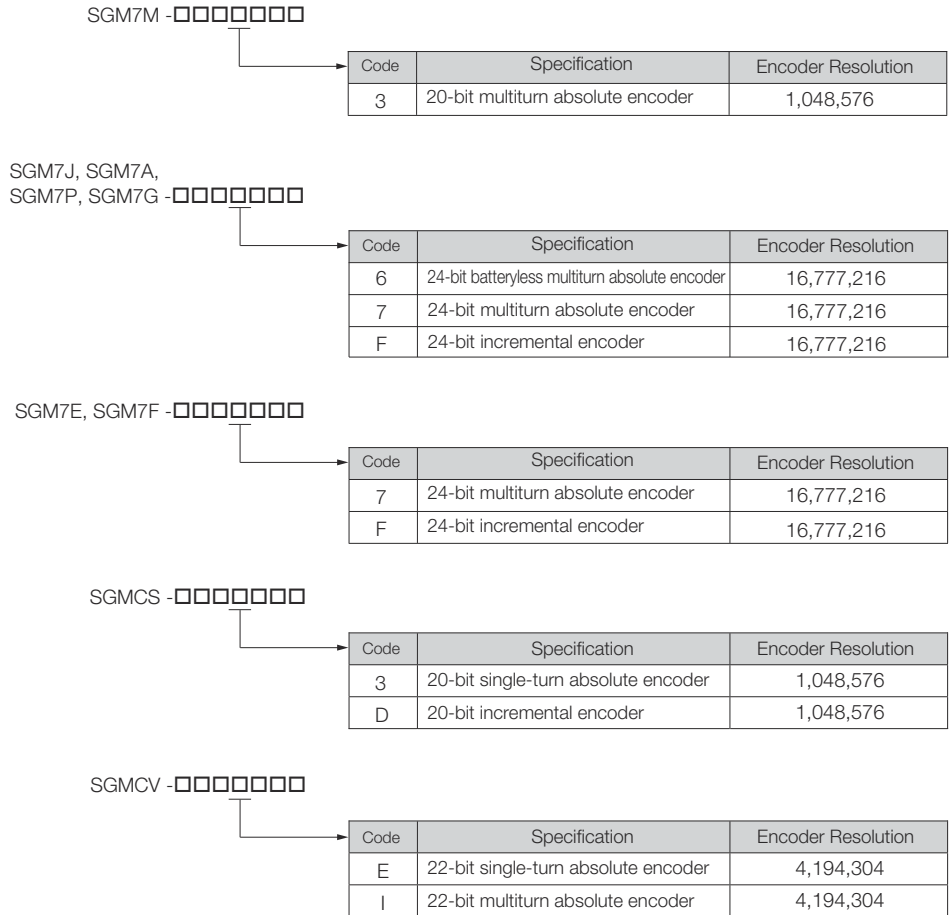


Fig. 128: Encoder Resolution in the Servomotor Model Number

Linear Servomotors

You can calculate the settings for the electronic gear ratio with the following equation:

When Not Using a Serial Converter Unit

Use the following formula if the linear encoder and SERVOPACK are connected directly or if a linear encoder that does not require a Serial Converter Unit is used.

$$\text{Electronic gear ratio } \frac{B}{A} = \frac{\text{Numerator}}{\text{Denominator}} = \frac{\text{Travel distance per reference unit (reference units)} \times \text{Linear encoder resolution}}{\text{Linear encoder pitch (the value from the following table)}}$$

Fig. 129: Calculating the Settings for the Electronic Gear Ratio - Linear Servomotors Formula without Serial Converter Unit

When Using a Serial Converter Unit

$$\text{Electronic gear ratio } \frac{B}{A} = \frac{\text{Numerator}}{\text{Denominator}} = \frac{\text{Travel distance per reference unit (reference units)} \times \text{Resolution of the Serial Converter Unit}}{\text{Linear encoder pitch (setting of Pn282)}}$$

Fig. 130: Calculating the Settings for the Electronic Gear Ratio - Linear Servomotors Formula with Serial Converter Unit

Feedback Resolution of Linear Encoder

The linear encoder pitches and resolutions are given in the following table.

Calculate the electronic gear ratio using the values in the following table.

Type of Linear Encoder	Manufacturer	Linear Encoder Model	Linear Encoder Pitch [μm]*1	Model of Serial Converter Unit or Model of Head with Interpolator	Resolution	Resolution
Incremental	Dr. JOHANNES HEIDENHAIN GmbH	LIDA48□	20	JZDP-H003-□□□-E*2	256	0.078 μm
				JZDP-J003-□□□-E*2	4,096	0.0049 μm

Type of Linear Encoder	Manufacturer	Linear Encoder Model	Linear Encoder Pitch [μm]*1	Model of Serial Converter Unit or Model of Head with Interpolator	Resolution	Resolution	
		LIF48□	4	JZDP-H003-□□□-E*2	256	0.016 μm	
				JZDP-J003-□□□-E*2	4,096	0.00098 μm	
	Renishaw PLC	RGH22B	20	JZDP-H005-□□□-E*2	256	0.078 μm	
				JZDP-J005-□□□-E*2	4,096	0.0049 μm	
	Magnescale Co., Ltd.	SR75-□□□□□LF*5	80	–	8,192	0.0098 μm	
		SR75-□□□□□MF	80	–	1,024	0.078 μm	
		SR85-□□□□□LF*5	80	–	8,192	0.0098 μm	
		SR85-□□□□□MF	80	–	1,024	0.078 μm	
		SL700*5, SL710*5, SL720*5, SL730*5	800	PL101-RY*3 MJ620-T13*4	8,192	0.0977 μm	
		SQ10	400	MQ10-FLA*4 MQ10-GLA*4	8,192	0.0488 μm	
	Absolute	Dr. JOHANNES HEIDENHAIN GmbH	LIC4100 Series	20.48	EIB3391Y*4	4,096	0.005 μm
			LIC2100 Series	204.8	EIB3391Y*4	4,096	0.05 μm
409.6				EIB3391Y*4	4,096	0.1 μm	
LC115			40.96	EIB3391Y*4	4,096	0.01 μm	
LC415			40.96	EIB3391Y*4	4,096	0.01 μm	
Mitutoyo Corporation		ST781A/ST781AL	256	–	512	0.5 μm	
		ST782A/ST782AL	256	–	512	0.5 μm	
		ST783/ST783AL	51.2	–	512	0.1 μm	
		ST784/ST784AL	51.2	–	512	0.1 μm	
		ST788A/ST788AL	51.2	–	512	0.1 μm	
		ST789A/ST789AL	25.6	–	512	0.05 μm	
		ST1381	5.12	–	512	0.01 μm	
		ST1382	0.512	–	512	0.001 μm	
Renishaw PLC		EL36Y-□□050F□□□□	12.8	–	256	0.05 μm	
		EL36Y-□□100F□□□□	25.6	–	256	0.1 μm	
		EL36Y-□□500F□□□□	128	–	256	0.5 μm	
		RL36Y-□□050□□□□□	12.8	–	256	0.05 μm	
		RL36Y-□□001□□□□□	0.256	–	256	0.001 μm	
Magnescale Co., Ltd.		SR77-□□□□□LF*5	80	–	8,192	0.0098 μm	
		SR77-□□□□□MF	80	–	1,024	0.078 μm	
		SR87-□□□□□LF*5	80	–	8,192	0.0098 μm	
		SR87-□□□□□MF	80	–	1,024	0.078 μm	
		SQ47/SQ57-□□□□□SF□□□□ SQ47/SQ57-□□□□□TF□□□□	20.48	–	4,096	0.005 μm	

Type of Linear Encoder	Manufacturer	Linear Encoder Model	Linear Encoder Pitch [μm]*1	Model of Serial Converter Unit or Model of Head with Interpolator	Resolution	Resolution
		SQ47/SQ57- □□□□A□F□□□ SQ47/SQ57- □□□□F□F□□□	40.96	–	4,096	0.01 μm
	Fagor Automation S. Coop	L2AK208	20	–	256	0.078 μm
		L2AK211	20	–	2,048	0.0098 μm
		LAK209	40	–	512	0.078 μm
		LAK212	40	–	4,096	0.0098 μm
		S2AK208	20	–	256	0.078 μm
		SV2AK208	20	–	256	0.078 μm
		G2AK208	20	–	256	0.078 μm
		S2AK211	20	–	2,048	0.0098 μm
		SV2AK211	20	–	2,048	0.0098 μm
		G2AK211	20	–	2,048	0.0098 μm

*1. These are reference values for setting SERVOPACK parameters. Contact the manufacturer for actual linear encoder scale pitches.

*2. This is the model of the Serial Converter Unit.

*3. This is the model of the Head with Interpolator.

*4. This is the model of the Interpolator.

*5. If you use an encoder pulse output with this linear encoder, the setting range of the encoder output resolution (Pn281) is restricted. Refer to the following section for details on the encoder output resolution (Pn281).

→ Chap. 7.6.3 ‘Setting for the Encoder Divided Pulse Output’ ...page 210



Resolution

You can calculate the resolution that is used inside the SERVOPACK (i.e., the travel distance per feedback pulse) with the following formula.

$$\text{Resolution (travel distance per feedback pulse)} = \frac{\text{Linear encoder pitch}}{\text{Resolution of Serial Converter Unit or linear encoder}}$$

Fig. 131: Calculation of the Travel Distance per Feedback Pulse used inside the SERVOPACK - Formula

The SERVOPACK uses feedback pulses as the unit to control a Servomotor.

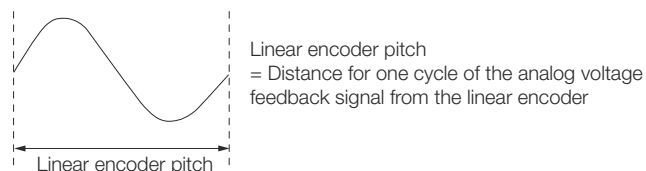
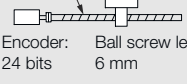
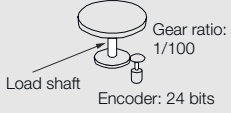
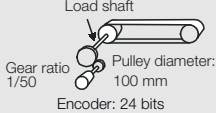


Fig. 132: Linear Encoder Pitch - Graphical Illustration

Electronic Gear Ratio Setting Examples

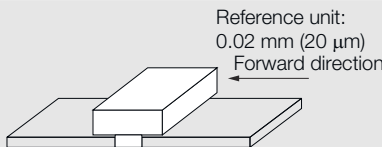
Setting examples are provided in this section.

Rotary Servomotors

Step	Description	Machine Configuration		
		Ball Screw	Rotary Table	Belt and Pulley
		Reference unit: 0.001 mm  Encoder: 24 bits Ball screw lead: 6 mm	Reference unit: 0.01°  Gear ratio: 1/100 Encoder: 24 bits	Reference unit: 0.005 mm  Gear ratio: 1/50 Pulley diameter: 100 mm Encoder: 24 bits
1	Machine Specifications	<ul style="list-style-type: none"> Ball screw lead: 6 mm Gear ratio: 1/1 	<ul style="list-style-type: none"> Rotation angle per revolution: 360° Gear ratio: 1/100 	<ul style="list-style-type: none"> Pulley dia.: 100 mm (Pulley circumference: 314 mm) Gear ratio: 1/50
2	Encoder Resolution	16,777,216 (24 bits)	16,777,216 (24 bits)	16,777,216 (24 bits)
3	Reference Unit	0.001 mm (1 μm)	0.01°	0.005 mm (5 μm)
4	Travel Distance per Load Shaft Revolution (Reference Units)	6 mm/0.001 mm = 6,000	360°/0.01° = 36,000	314 mm/0.005 mm = 62,800
5	Electronic Gear Ratio*	$\frac{B}{A} = \frac{16,777,216}{6,000} \times \frac{1}{1}$	$\frac{B}{A} = \frac{16,777,216}{36,000} \times \frac{100}{1}$	$\frac{B}{A} = \frac{16,777,216}{36,000} \times \frac{50}{1}$
6	Position User Unit (2301h)	Numerator: 16,777,216	Numerator: 1,677,721,600	Numerator: 838,860,800
		Denominator: 6,000	Denominator: 36,000	Denominator: 62,800

Linear Servomotors

A setting example for a Serial Converter Unit resolution of 256 is given below.

Step	Description	Machine Configuration
		Reference unit: 0.02 mm (20 μm) 
1	Linear Encoder Pitch	0.02 mm (20 μm)
2	Reference Unit	0.001 mm (1 μm)
3	Electronic Gear Ratio*	$\frac{B}{A} = \frac{1 (\mu\text{m})}{20 (\mu\text{m})} \times \frac{1}{1}$
4	Position User Unit (2301h)	Numerator: 256
		Denominator: 20

6.15.3 Setting the Speed Reference Unit

Set the speed reference unit [Vel. Unit] in *Velocity User Unit* (2302h).



The query of validity is Max. Motor velocity (2312h) $\leq 2^{31}$
If the setting range is exceeded, an A.A20 alarm (Parameter Setting Error) will occur.

Index	Subindex	Name	Data Type	Access	PDO Mappings	Value	Saving to EEPROM
2302h	1	Numerator	UDINT	RW	No	$1 \leq \text{Value range} \leq 2^{31}-1$ (default: 1)	Yes
	2	Denominator	UDINT	RW	No	$1 \leq \text{Value range} \leq 2^{31}-1$ (default: 1)	Yes

Example

Speed Reference Unit Setting Example (Electronic Gear Ratio Setting Example for a Ball Screw, Ball screw lead = 6 mm, Encoder resolution = 16,777,216 inc (24 bits))
→ 'Electronic Gear Ratio Setting Examples' ...page 176

■ Velocity User Unit (2302h)

Converting one user-defined velocity reference unit [0.1 mm/s] into [inc/ms]:

$$\begin{aligned}
 & 1 \text{ [Vel. unit]} \\
 & = 0.1 \text{ mm/s} = 0.0001 \text{ [mm/ms]} \\
 & = \frac{16,777,216 \text{ [inc]}}{6 \text{ [mm]}} \times 0.0001 \text{ [mm/ms]} \\
 & = \frac{16,777,216}{60,000} \text{ [inc/ms]}
 \end{aligned}$$

Fig. 133: Speed Reference Unit Setting Example

Therefore, the objects are set as follows:

Object 2302h:01 (Numerator) = 16,777,216

Object 2302h:02 (Denominator) = 60,000

6.15.4 Setting the Acceleration Reference Unit

Set the acceleration reference unit [Acc. Unit] in *Acceleration User Unit* (2303h).



The query of validity is Max. Motor Acceleration (2313h) $\leq 2^{31}$
If the setting range is exceeded, an A.A20 alarm (Parameter Setting Error) will occur.

Index	Subindex	Name	Data Type	Access	PDO Mappings	Value	Saving to EEPROM
2303h	1	Numerator	UDINT	RW	No	$1 \leq \text{Value range} \leq 2^{31}-1$ (default: 1)	Yes

Index	Subindex	Name	Data Type	Access	PDO Mappings	Value	Saving to EEPROM
	2	Denominator	UDINT	RW	No	$1 \leq \text{Value range} \leq 2^{31}-1$ (default: 1)	Yes

Example

Acceleration Reference Unit Setting Example (Electronic Gear Ratio Setting Example for a Ball Screw, Ball screw lead = 6 mm, Encoder resolution = 16,777,216 inc (24 bits))
 → 'Electronic Gear Ratio Setting Examples' ...page 176

- Acceleration User Unit (2303h)

Converting one user-defined acceleration reference unit [0.1 mm/s²] into [10⁴ inc/s²]:

$$\begin{aligned}
 & 1 \text{ [Acc unit]} \\
 &= \frac{16,777,216 \text{ [inc]}}{6 \text{ [mm]}} \times 0.1 \text{ [mm/s}^2\text{]} \times 10^{-4} \\
 &= \frac{16,777,216}{6 \times 10^5} \text{ [10}^4 \text{ inc/s}^2\text{]}
 \end{aligned}$$

Fig. 134: Acceleration Reference Unit Setting Example

Therefore, the objects are set as follows:

Object 2303h:01 (Numerator) = 16,777,216

Object 2303h:02 (Denominator) = 600,000

6.16 Resetting the Absolute Encoder

6.16.1 Overview

In a system that uses an absolute encoder, the multiturn data must be reset at startup. An alarm related to the absolute encoder (A.810 or A.820) will occur when the absolute encoder must be reset, such as when the power supply is turned ON.

When you reset the absolute encoder, the multiturn data is reset and any alarms related to the absolute encoder are cleared.

Reset the absolute encoder in the following cases:

- When an A.810 alarm (Encoder Backup Alarm) occurs
- When an A.820 alarm (Encoder Checksum Alarm) occurs
- When starting the system for the first time
- When you want to reset the multiturn data in the absolute encoder
- When the Servomotor has been replaced

**CAUTION**

The multiturn data will be reset to a value between -2 and +2 rotations when the absolute encoder is reset. The reference position of the machine system will change. Adjust the reference position in the host controller to the position that results from resetting the absolute encoder.

If the machine is started without adjusting the position in the host controller, unexpected operation may cause personal injury or damage to the machine.



- *The multiturn data will always be zero in the following cases. It is never necessary to reset the absolute encoder in these cases. An alarm related to the absolute encoder (A.810 or A.820) will not occur.*
 - *When you use a single-turn absolute encoder*
 - *When the encoder is set to be used as a single-turn absolute encoder (Pn002 = n.□2□□)*
- *If a batteryless absolute encoder is used, an A.810 alarm (Encoder Backup Alarm) will occur the first time the power is turned ON. After you reset the absolute encoder, the A.810 alarm will no longer occur.*

6.16.2 Precautions on Resetting

- You cannot use the Alarm/Warning Clear (Fault Reset) command from the SERVOPACK to clear the A.810 alarm (Encoder Backup Alarm) or the A.820 alarm (Encoder Checksum Alarm). Always use the operation to reset the absolute encoder to clear these alarms.
- If an A.8□□ alarm (Internal Encoder Monitoring Alarm) occurs, turn OFF the power supply to reset the alarm.

6.16.3 Preparations

Always check the following before you reset an absolute encoder.

- The parameters must not be write prohibited.
- The servo must be OFF.


6.16.4 Applicable Tools

The following table lists the tools that you can use to reset the absolute encoder and the applicable tool functions.

Tool	Function	Reference
Digital Operator	Fn008	Σ-7-Series Digital Operator Operating Manual (Manual No.: SIEP S800001 33)
SigmaWin+	Setup - Absolute Encoder Reset	➔ Chap. 6.16.5 'Operating Procedure' ...page 180

6.16.5 Operating Procedure

Use the following procedure to reset the absolute encoder.

1. ➔ Confirm that the servo is OFF.
2. ➔ Click the  Servo Drive Button in the workspace of the Main Window of the SigmaWin+.
3. ➔ Select Absolute Encoder Reset in the Menu Dialog Box.
The Absolute Encoder Reset Dialog Box will be displayed.

4. → Click the Continue Button.

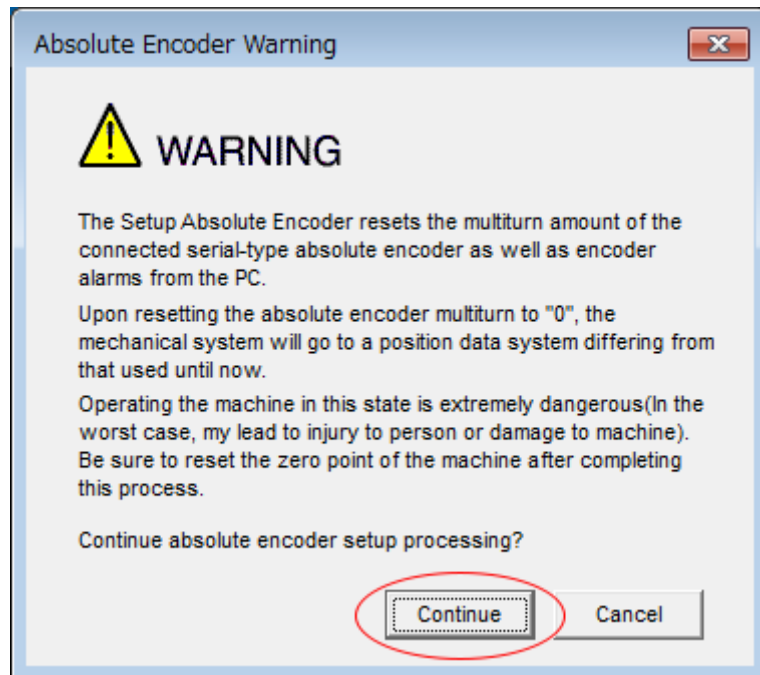


Fig. 135: Absolute Encoder Warning

- ➔ Click the Cancel Button to cancel resetting the absolute encoder. The Main Window will return.

5. → Click the Execute setting Button.

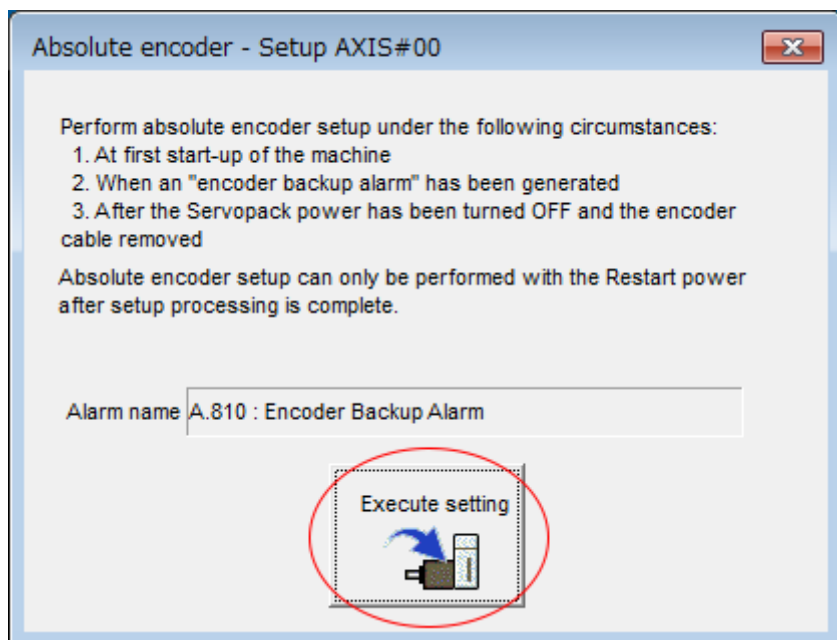


Fig. 136: Absolute Encoder - Setup AXIS #00 - Execute Setting

- ➔ The current alarm code and name will be displayed in the Alarm name Box.

6. → Click the Continue Button.

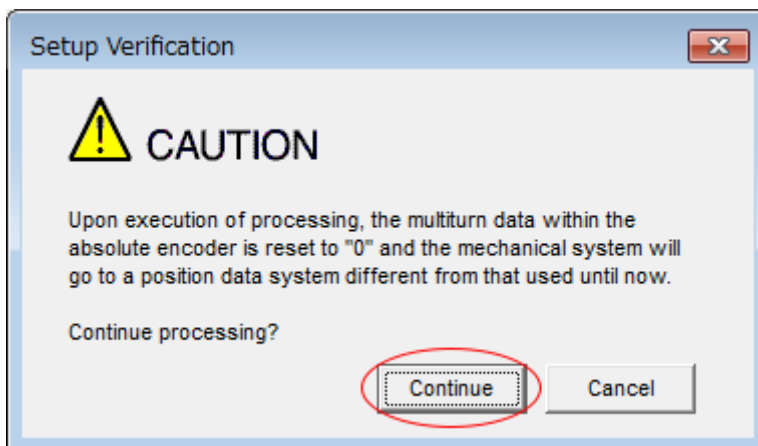


Fig. 137: Setup Verification - Continue processing

- ➔ Click the Cancel Button to cancel resetting the absolute encoder. The previous dialog box will return.

7. → Click the OK Button.

The absolute encoder will be reset.

- ➔ ■ When Resetting Fails

If you attempted to reset the absolute encoder when the servo was ON in the SERVOPACK, the following dialog box will be displayed and processing will be canceled.

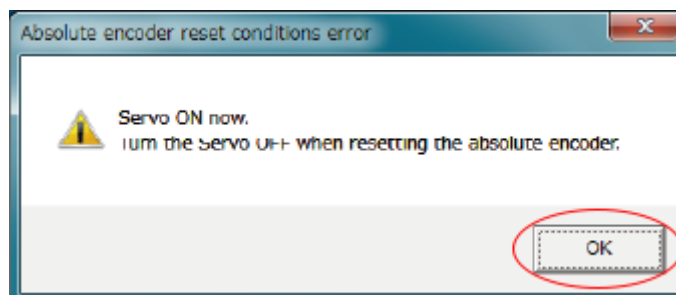


Fig. 138: Absolute encoder reset conditions error

Click the OK Button. The Main Window will return. Turn OFF the servo and repeat the procedure from step 1.

- When Resetting Is Successful

The following dialog box will be displayed when the absolute encoder has been reset.

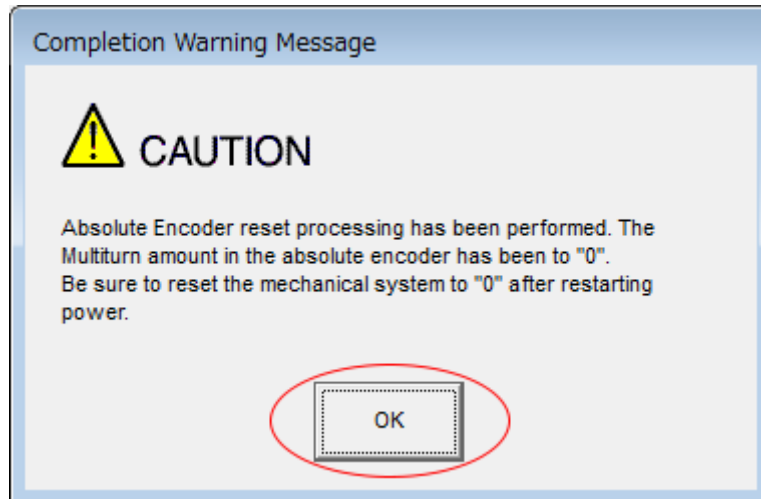


Fig. 139: Completion Warning Message

The Main Window will return.

8. → To enable the change to the settings, turn the power supply to the SERVOPACK OFF and ON again.

This concludes the procedure to reset the absolute encoder.

6.17 Setting the Origin of the Absolute Encoder

6.17.1 Absolute Encoder Origin Offset

The origin offset of the absolute encoder is a correction that is used to set the origin of the machine coordinate system in addition to the origin of the absolute encoder. Set the offset between the absolute encoder origin and the machine coordinate system position in *Home Offset* (607Ch).

Index	Sub-index	Name	Data Type	Access	Data Ranges	Default Value	Saving to EEPROM
607Ch	0	Home Offset	DINT	RW	80000000h to 7FFFFFFF resp. -2.147.483.648 to 2.147.483.647	0	Yes

Example

If the encoder position (X) is at the origin (0), then home offset (607Ch) would be set to the value of -X.

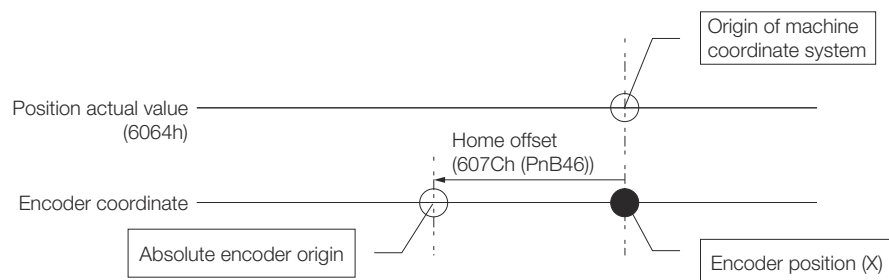



Fig. 140: Absolute Encoder Origin Offset

6.17.2 Setting the Origin of the Absolute Linear Encoder

You can set any position as the origin in the following linear encoders.

Setting the Origin of the Absolute Encoder > Setting the Origin of the Absolute Linear Encoder

- From Mitutoyo Corporation
ABS ST780A Series or ST1300 Series
Models: ABS ST78□A/ST78□AL/ST13□□
- Renishaw PLC
EVOLUTE Series
Models: EL36Y-□□□□□□□□
- Renishaw PLC
RESOLUTE Series
Models: RL36Y-□□□□□□□□



- After you set the origin, the /S-RDY (Servo Ready) signal will become inactive because the system position data was changed. Always turn the SERVOPACK power supply OFF and ON again.
- After you set the origin, the Servomotor phase data in the SERVOPACK will be discarded. If you are using a Linear Servomotor without a Polarity Sensor, execute polarity detection again to save the Servomotor phase data in the SERVOPACK.


Preparations

The following conditions must be met to set the origin of the absolute linear encoder.

- The parameters must not be write prohibited.
- The servo must be OFF.




Applicable Tools

The following table lists the tools that you can use to set the origin of the absolute linear encoder and the applicable tool functions.

Tool	Function	Reference
Digital Operator	Fn020	 Σ-7-Series Digital Operator Operating Manual (Manual No.: SIEP S800001 33)
SigmaWin+	Setup - Set Origin	↪ 'Operating Procedure' ...page 184

Operating Procedure

Use the following procedure to set the origin of an absolute linear encoder.

1.  Click the  Servo Drive Button in the workspace of the Main Window of the SigmaWin+.
2.  Select Set Origin in the Menu Dialog Box.
 - ➔ The Set Origin Dialog Box will be displayed.

Setting the Origin of the Absolute Encoder > Setting the Origin of the Absolute Linear Encoder

3. Click the Continue Button.

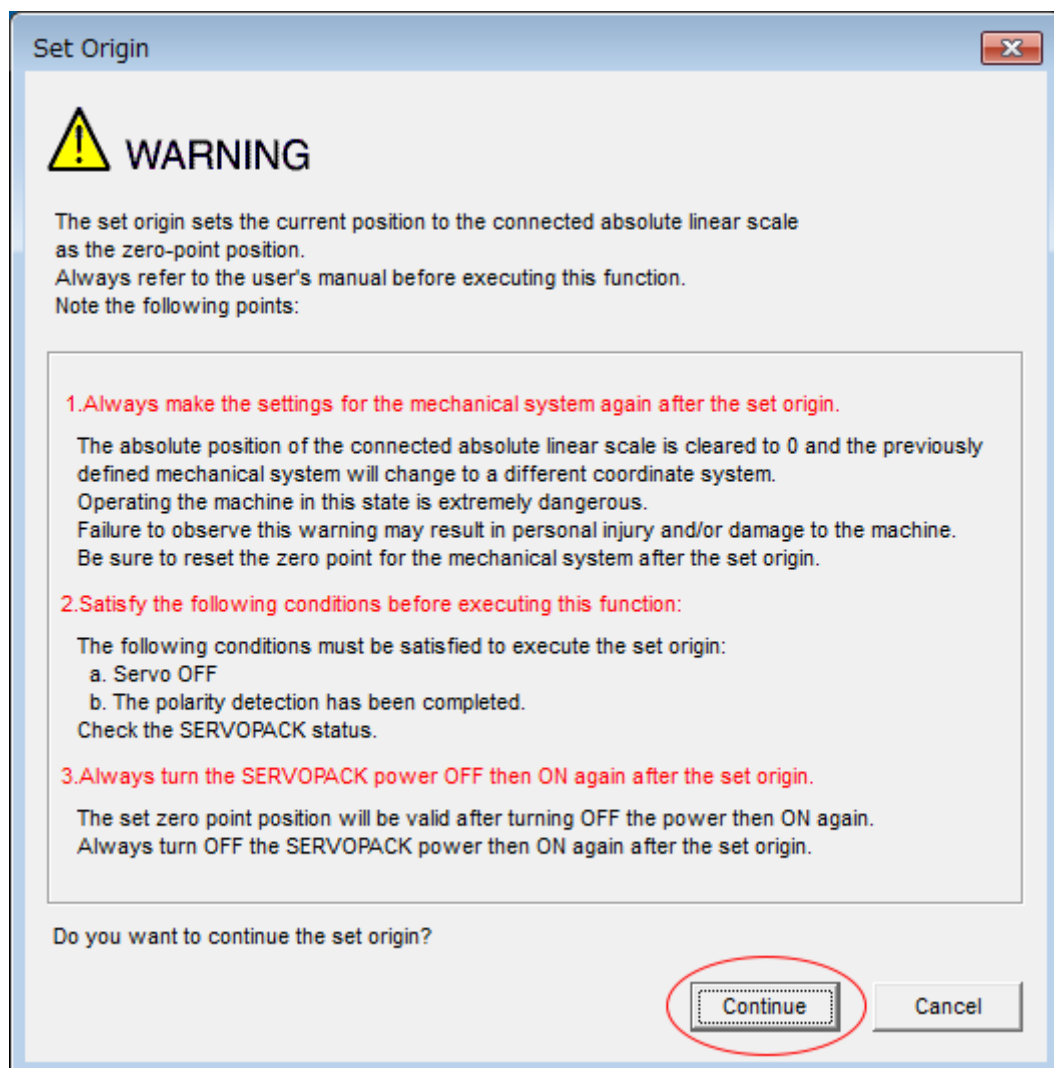


Fig. 141: Set Origin - Warning

Setting the Origin of the Absolute Encoder > Setting the Origin of the Absolute Linear Encoder

4. → Click the Execute Button.

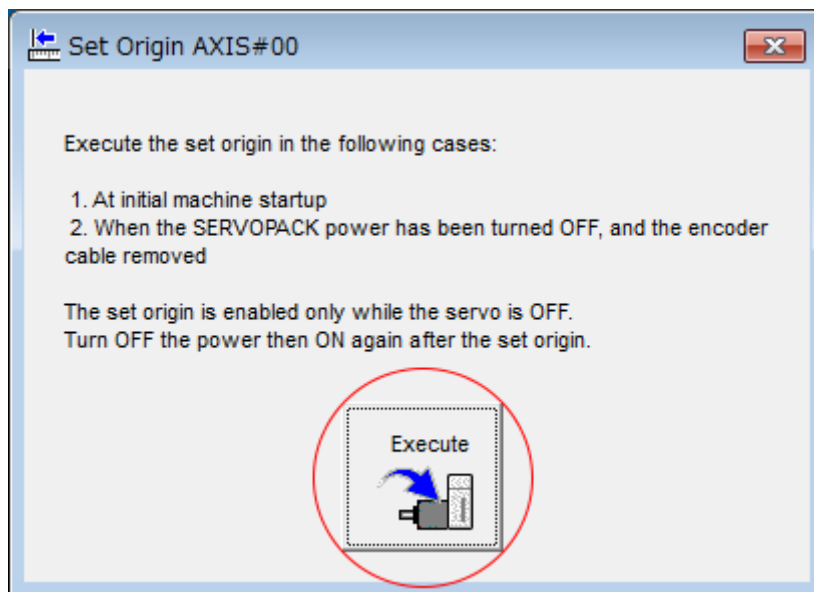


Fig. 142: Set Origin AXIS#00

5. → Click the Continue Button.

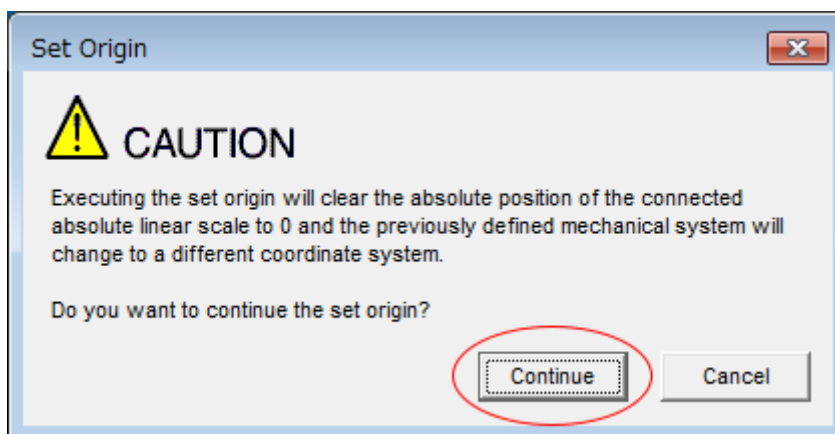


Fig. 143: Set Origin - Caution

- ➔ Click the Cancel Button to cancel setting the origin of the absolute linear encoder. The previous dialog box will return.

6. Click the OK Button.

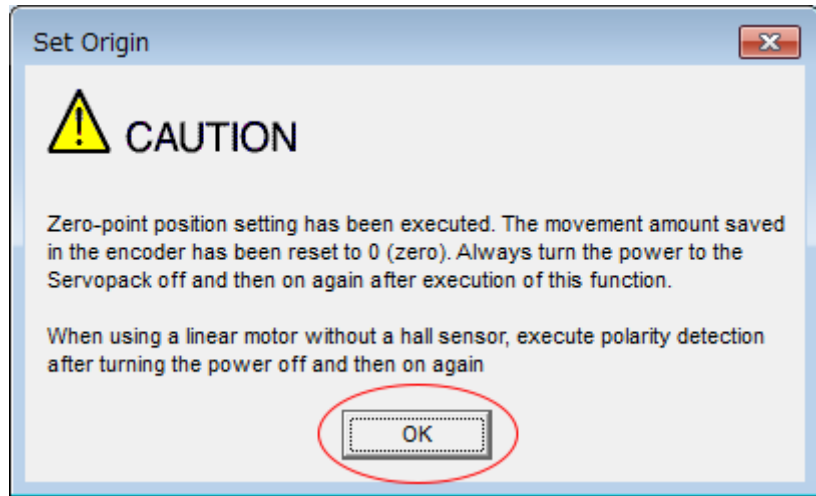


Fig. 144: Set Origin - Caution 2

7. Turn the power supply to the SERVOPACK OFF and ON again.
8. If you use a Linear Servomotor that does not have a polarity sensor, perform polarity detection.

Refer to the following section for details on the polarity detection.

→ [Chap. 6.10.1 'Polarity Detection' ...page 152](#)

This concludes the procedure to set the origin of the absolute linear encoder.

6.18 Setting the Regenerative Resistor Capacity

The regenerative resistor consumes regenerative energy that is generated by the Servomotor, e.g., when the Servomotor decelerates.

If an External Regenerative Resistor is connected, you must set Pn600 (Regenerative Resistor Capacity) and Pn603 (Regenerative Resistance).

Refer to the following manual to select the capacity of a Regenerative Resistor.

📖 [Σ-7-Series Peripheral Device Selection Manual \(Manual No.: SIEP S800001 32\)](#)



WARNING

- If you connect an External Regenerative Resistor, set Pn600 and Pn603 to suitable values.
If a suitable value is not set, A.320 alarms (Regenerative Overload) will not be detected correctly, and the External Regenerative Resistor may be damaged or personal injury or fire may result.
- When you select an External Regenerative Resistor, make sure that it has a suitable capacity.
There is a risk of personal injury or fire.

Regenerative Resistor Capacity

	Setting Range	Setting Unit	Default Setting	When Enabled	Classification
Pn600	0 to SERVO-PACK's maximum applicable motor capacity	10 W	0	Immediately	Setup

Setting the Regenerative Resistor Capacity

(applies to Speed Control, Position Control and Torque Control)

Regenerative Resistor Resistance

	Setting Range	Setting Unit	Default Setting	When Enabled	Classification
Pn603	0 to 65,535	10 mΩ	0	Immediately	Setup

(applies to Speed Control, Position Control and Torque Control)

Set the Regenerative Resistor capacity to a value that is consistent with the allowable capacity of the External Regenerative Resistor. The setting depends on the cooling conditions of the External Regenerative Resistor.

- For self-cooling (natural convection cooling): Set the parameter to a maximum 20% of the capacity (W) of the actually installed Regenerative Resistor.
- For forced-air cooling: Set the parameter to a maximum 50% of the capacity (W) of the actually installed Regenerative Resistor.

Example

For a self-cooling 100-W External Regenerative Resistor, set Pn600 to 2 (×10 W) (100 W × 20% = 20 W).



- An A.320 alarm will be displayed if the setting is not suitable.
- The default setting of 0 specifies that the SERVOPACK's built-in regenerative resistor or Yaskawa's Regenerative Resistor Unit is being used.



- When an External Regenerative Resistor is used at the normal rated load ratio, the resistor temperature increases to between 200°C and 300°C. Always apply derating. Consult the manufacturer for the resistor's load characteristics.
- For safety, use an External Regenerative Resistor with a thermoswitch.

7 Application Functions

7.1 Overview

This chapter describes the application functions that you can set before you start servo system operation. It also describes the setting methods.

7.2 I/O Signal Allocations

7.2.1 Overview

Functions are allocated to the pins on the I/O signal connector (CN1) in advance. You can change the allocations and the polarity for some of the connector pins. Function allocations and polarity settings are made with parameters.

This section describes the I/O signal allocations.

7.2.2 Input Signal Allocations



- If you change the default polarity settings for the P-OT (Forward Drive Prohibit) or N-OT (Reverse Drive Prohibit) signal, the overtravel function will not operate if there are signal line disconnections or other problems. If you must change the polarity of one of these signals, verify operation and make sure that no safety problems will exist.
- If you allocate two or more signals to the same input circuit, a logical OR of the inputs will be used and all of the allocated signals will operate accordingly. This may result in unexpected operation.


The input signals that you can allocate to the pins on the I/O signal connector (CN1) and the related parameters are given in the following table.

Input Signal	Input Signal Name	Parameter
P-OT	Forward Drive Prohibit	Pn50A = n.X□□□
N-OT	Reverse Drive Prohibit	Pn50B = n.□□□X
/P-CL	Forward External Torque Limit	Pn50B = n.□X□□
/N-CL	Reverse External Torque Limit	Pn50B = n.X□□□
/EXT1	Probe 1 Latch Input	Pn511 = n.□□X□
/EXT2	Probe 2 Latch Input	Pn511 = n.□X□□
/DEC	Home Switch Input	Pn511 = n.□□□X
FSTP	Forced Stop	Pn516 = n.□□□X

Relationship between Parameter Settings, Allocated Pins, and Polarities

The following table shows the relationship between the input signal parameter settings, the pins on the I/O signal connector (CN1), and polarities.

Parameter Setting	Pin No.	Description
0	13	
1	7	
2	8	
3	9	A reverse signal (a signal with "/" before the signal abbreviation, such as the /P-CL signal) is active when the contacts are ON (closed).

Parameter Setting	Pin No.	Description	
4	10	A signal that does not have “/” before the signal abbreviation (such as the POT signal) is active when the contacts are OFF (open).	
5	11		
6	12		
7	–	The input signal is not allocated to a connector pin and it is always active. If the signal is processed on a signal edge, then it is always inactive.	
8	–	The input signal is not allocated to a connector pin and it is always inactive. Set the parameter to 8 if the signal is not used.	
9	13		
A	7		
B	8		A reverse signal (a signal with “/” before the signal abbreviation, such as the / P-CL signal) is active when the contacts are OFF (open).
C	9		A signal that does not have “/” before the signal abbreviation (such as the POT signal) is active when the contacts are ON (closed).
D	10		
E	11		
F	12		



- You can allocate the /EXT1 and /EXT2 input signals only to pins 10 to 12 on the I/O signal connector (CN1).
- Refer to the following section for details on input signal parameter settings.
[↪ Chap. 17.2.2 ‘List of Parameters’ ...page 623](#)

Example of Changing Input Signal Allocations

The following example shows reversing the P-OT (Forward Drive Prohibit) signal allocated to CN1-7 and the /DEC (Home Switch Input) signal allocated to CN1-9.

Pn50A = n.1□□□	Pn511 = n.3□□□	Before change
↓	↓	
Pn50A = n.3□□□	Pn511 = n.1□□□	After change

Refer to the following section for the parameter setting procedure.

[↪ Chap. 6.2.4 ‘Setting Methods for SERVOPACK Parameters’ ...page 129](#)

Confirming Input Signals

You can confirm the status of input signals on the I/O signal monitor. Refer to the following section for information on the I/O signal monitor.

[↪ Chap. 10.3.3 ‘I/O Signal Monitor’ ...page 414](#)

7.2.3 Output Signal Allocations

You can allocate the desired output signals to pins 1, 2, and 23 to 26 on the I/O signal connector (CN1). You set the allocations in the following parameters: Pn50E, Pn50F, Pn510, and Pn514.



- The signals that are not detected are considered to be OFF. For example, the /COIN (Positioning Completion) signal is considered to be OFF during speed control.
- Reversing the polarity of the /BK (Brake) signal, i.e., changing it to positive logic, will prevent the holding brake from operating if its signal line is disconnected. If you must change the polarity of this signal, verify operation and make sure that no safety problems will exist.
- If you allocate more than one signal to the same output circuit, a logical OR of the signals will be output.

Output signals are allocated as shown in the following table.

Refer to [further information ...page 190](#) and change the allocations accordingly.

Interpreting the Output Signal Allocation Tables

These columns give the parameter settings to use. Signals are allocated to CN1 pins according to the settings.

Output Signal Name and Parameter	Output Signals	CN1 Pin No.			Disabled (Not Used)
		1 and 2	23 and 24	25 and 26	
Brake Pn50F = □X□□	/BK	1	2	3	0

Fig. 145: Interpreting the Output Signal Allocation Tables - Header

Output Signal Name and Parameter	Output Signals	CN1 Pin No.			Disabled (Not Used)
		1 and 2	23 and 24	25 and 26	
Positioning Completion Pn50E = n.□□□X	/COIN	1	2	3	0 (default setting)
Speed Coincidence Detection Pn50E = n.□□X□	/V-CMP	1	2	3	0 (default setting)
Rotation Detection Pn50E = n.□X□□	/TGON	1	2	3	0 (default setting)
Servo Ready Pn50E = n.X□□□	/S-RDY	1	2	3	0 (default setting)
Torque Limit Detection Pn50F = n.□□□X	/CLT	1	2	3	0 (default setting)
Speed Limit Detection Pn50F = n.□□X□	/VLT	1	2	3	0 (default setting)
Brake Pn50F = n.□X□□	/BK	1 (default setting)	2	3	0
Warning Pn50F = n.X□□□	/WARN	1	2	3	0 (default setting)
Near Pn510 = n.□□□X	NEAR	1	2	3	0 (default setting)
Preventative Maintenance Pn514 = n.□X□□	/PM	1	2	3	0 (default setting)
Pn512 = n.□□□1	Reverse polarity for CN1-1 and CN1-2				0 (default setting) (The polarity is not

Output Signal Name and Parameter	Output Signals	CN1 Pin No.			Disabled (Not Used)
		1 and 2	23 and 24	25 and 26	
Pn512 = n.□□1□	Reverse polarity for CN1-23 and CN1-24				reversed in the default settings.)
Pn512 = n.□1□□	Reverse polarity for CN1-25 and CN1-26				

Example of Changing Output Signal Allocations

The following example shows disabling the /COIN (Positioning Completion) signal allocated to CN1-25 and CN1-26 and allocating the /SRDY (Servo Ready) signal.

Pn50E = n.0□□3	Before change
↓	
Pn50E = n.3□□0	After change

Refer to the following section for the parameter setting procedure.

➔ [Chap. 6.2.4 'Setting Methods for SERVOPACK Parameters' ...page 129](#)


Checking Output Signal Status

You can confirm the status of output signals on the I/O signal monitor. Refer to the following section for information on the I/O signal monitor.

➔ [Chap. 10.3.3 'I/O Signal Monitor' ...page 414](#)

7.2.4 ALM (Servo Alarm) Signal

This signal is output when the SERVOPACK detects an error.



Configure an external circuit so that this alarm output turns OFF the main circuit power supply to the SERVOPACK whenever an error occurs.

Type	Signal	Connector Pin No.	Signal Status	Meaning
Output	ALM	CN1-3 and CN1-4	ON (closed)	Normal SERVOPACK status
			OFF (open)	SERVOPACK alarm

Alarm Reset Methods

Refer to the following section for information on the alarm reset methods.

➔ [Chap. 16.4.4 'Resetting Alarms' ...page 594](#)

7.2.5 /WARN (Warning) Signal

Both alarms and warnings are generated by the SERVOPACK. Alarms indicate errors in the SERVOPACK for which operation must be stopped immediately. Warnings indicate situations that may result in alarms but for which stopping operation is not yet necessary.

The /WARN (Warning) signal indicates that a condition exists that may result in an alarm.

Type	Signal	Connector Pin No.	Signal Status	Meaning
Output	/WARN	Must be allocated.	ON (closed)	Warning
			OFF (open)	Normal status



You must allocate the /WARN signal to use it. Use Pn50F = n.X□□□ (/WARN (Warning Output) Signal Allocation) to allocate the signal to a connector pin. Refer to the following section for details.

→ Chap. 7.2.3 'Output Signal Allocations' ...page 190

7.2.6 /TGON (Rotation Detection) Signal

The /TGON signal indicates that the Servomotor is operating.

This signal is output when the shaft of the Servomotor rotates at the setting of Pn502 (Rotation Detection Level) or faster or the setting of Pn581 (Zero Speed Level) or faster.

Type	Signal	Connector Pin No.	Signal Status	Servomotor	Meaning
Output	/TGON	Must be allocated.	ON (closed)	Rotary Servomotors	The Servomotor is operating at the setting of Pn502 or faster.
				Linear Servomotors	The Servomotor is operating at the setting of Pn581 or faster.
			OFF (open)	Rotary Servomotors	The Servomotor is operating at a speed that is slower than the setting of Pn502.
				Linear Servomotors	The Servomotor is operating at a speed that is slower than the setting of Pn581.



You must allocate the /TGON signal to use it. Use Pn50E = n.□X□□ (/TGON (Rotation Detection Output) Signal Allocation) to allocate the signal to a connector pin. Refer to the following section for details.

→ Chap. 7.2.3 'Output Signal Allocations' ...page 190

Setting the Rotation Detection Level

Use the following parameter to set the speed detection level at which to output the /TGON signal.

- Rotary Servomotors

Rotation Detection Level

	Setting Range	Setting Unit	Default Setting	When Enabled	Classification
Pn502	1 to 10,000	1 min ⁻¹	20	Immediately	Setup

(applies to Speed Control, Position Control and Torque Control)

- Linear Servomotors

Zero Speed Level

	Setting Range	Setting Unit	Default Setting	When Enabled	Classification
Pn581	1 to 10,000	1 mm/s	20	Immediately	Setup

(applies to Speed Control, Position Control and Torque Control)

7.2.7 /S-RDY (Servo Ready) Signal

The /S-RDY (Servo Ready) signal turns ON when the SERVOPACK is ready to accept the Servo ON command (Enable Operation command).

The /S-RDY signal is turned ON under the following conditions.

- Main circuit power supply is ON.
- There is no hard wire base block state.
- There are no alarms.
- If a Servomotor without a polarity sensor is used, polarity detection has been completed.*

* Do not include this condition if the Servo ON command (Enable Operation command) is input for the first time after the control power supply was turned ON. In that case, when the first Servo ON command (Enable Operation command) is input, polarity detection is started immediately and the /S-RDY signal turns ON at the completion of polarity detection.

Type	Signal	Connector Pin No.	Signal Status	Meaning
Output	/S-RDY	Must be allocated.	ON (closed)	Ready to receive Servo ON command (Enable Operation command).
			OFF (open)	Not ready to receive Servo ON command (Enable Operation command).



- You must allocate the /S-RDY signal to use it. Use Pn50E = n.X□□□ (/S-RDY (Servo Ready) Signal Allocation) to allocate the signal to a connector pin. Refer to the following section for details.
[↪ Chap. 7.2.3 'Output Signal Allocations' ...page 190](#)
- Refer to the following section for information on the hard wire base block and the /S-RDY signal.
[↪ Chap. 12.3.9 'S-RDY \(Servo Ready Output\) Signal' ...page 446](#)

7.2.8 /V-CMP (Speed Coincidence Detection) Signal

The /V-CMP (Speed Coincidence Detection Output) signal is output when the Servomotor speed is the same as the reference speed. This signal is used, for example, to interlock the SERVOPACK and the host controller. You can use this output signal only during speed control.

The /V-CMP signal is described in the following table.

Type	Signal	Connector Pin No.	Signal Status	Meaning
Output	/V-CMP	Must be allocated.	ON (closed)	The speed coincides.
			OFF (open)	The speed does not coincide.



You must allocate the /V-CMP signal to use it. Use Pn50E = n.□□X□ (/V-CMP (Speed Coincidence Detection Output) Signal Allocation) to allocate the signal to connector pins. Refer to the following section for details on allocations.

→ Chap. 7.2.3 'Output Signal Allocations' ...page 190

You can set the speed detection width for the /V-CMP signal in Pn503 (Speed Coincidence Detection Signal Output Width) for a Rotary Servomotor or in Pn582 (Speed Coincidence Detection Signal Output Width) for a Linear Servomotor.

Rotary Servomotors

Speed Coincidence Signal Detection Width

	Setting Range	Setting Unit	Default Setting	When Enabled	Classification
Pn503	0 to 100	1 min ⁻¹	10	Immediately	Setup

(applies to Speed Control)

The signal is output when the difference between the reference speed and motor speed is equal or less than the setting.

Example

If Pn503 is set to 100 and the speed reference is 2,000 min⁻¹, the signal would be output when the motor speed is between 1,900 and 2,100 min⁻¹.

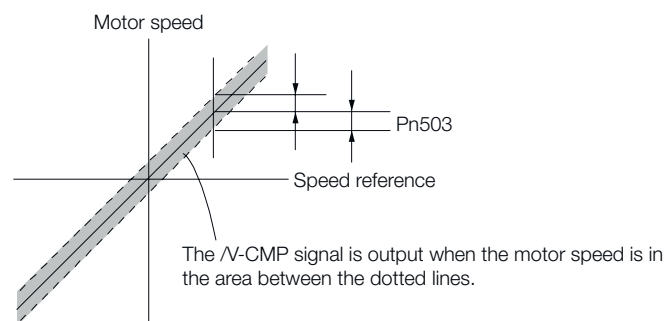


Fig. 146: /V-CMP (Speed Coincidence Detection) Signal - Rotary Servomotors

Linear Servomotors

Speed Coincidence Signal Detection Width

	Setting Range	Setting Unit	Default Setting	When Enabled	Classification
Pn582	0 to 100	1 mm/s	10	Immediately	Setup

(applies to Speed Control)

The signal is output when the difference between the reference speed and motor speed is equal or less than the setting.

Example

If Pn582 is set to 100 and the speed reference is 2,000 mm/s the signal would be output when the motor speed is between 1,900 and 2,100 mm/s.

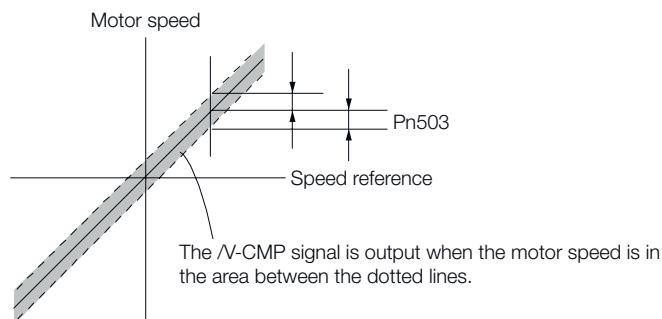


Fig. 147: V-CMP (Speed Coincidence Detection) Signal - Rotary Servomotors

7.2.9 /COIN (Positioning Completion) Signal

The /COIN (Positioning Completion) signal indicates that Servomotor positioning has been completed during position control.

The /COIN signal is output when the difference between the reference position output by the host controller and the current position of the Servomotor (i.e., the position deviation as given by the value of the deviation counter) is equal to or less than the setting of the positioning completed width (Pn522).

Use this signal to check the completion of positioning from the host controller.

Type	Signal	Connector Pin No.	Signal Status	Meaning
Output	/COIN	Must be allocated.	ON (closed)	Positioning has been completed.
			OFF (open)	Positioning has not been completed.



You must allocate the /COIN signal to use it. Use Pn50E = n.□□□X (/COIN (Positioning Completion Output) Signal Allocation) to allocate the signal to connector pins. Refer to the following section for details on allocations.

→ Chap. 7.2.3 'Output Signal Allocations' ...page 190

Setting the Positioning Completed Width

The /COIN signal is output when the difference between the reference position and the current position (i.e., the position deviation as given by the value of the deviation counter) is equal to or less than the setting of the positioning completed width (Pn522).

Positioning Completed Width

	Setting Range	Setting Unit	Default Setting	When Enabled	Classification
Pn522	0 to 1,073,741,824	1 reference unit	7	Immediately	Setup

(applies to Position Control)

The setting of the positioning completed width has no effect on final positioning accuracy.

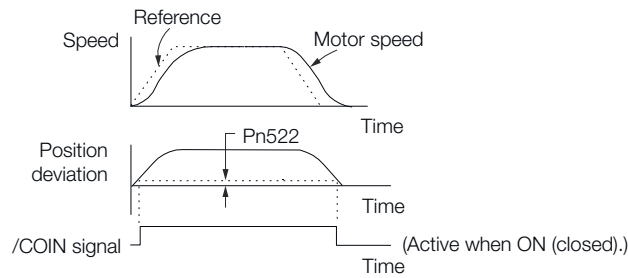


Fig. 148: Setting the Positioning Completed Width



If the parameter is set to a value that is too large, the /COIN signal may be output when the position deviation is low during a low-speed operation. If that occurs, reduce the setting until the signal is no longer output.

Setting the Output Timing of the /COIN (Positioning Completion Output) Signal

You can add a reference input condition to the output conditions for the /COIN signal to change the signal output timing.

If the position deviation is always low and a narrow positioning completed width is used, change the setting of Pn207 = n.X□□□ (/COIN (Positioning Completion Output) Signal Output Timing) to change output timing for the /COIN signal.

Parameter	Meaning	When Enabled	Classification	
Pn207	n.0□□□ (default setting)	Output the /COIN signal when the absolute value of the position deviation is the same or less than the setting of Pn522 (Positioning Completed Width).	After restart	Setup
	n. 1□□□	Output the /COIN signal when the absolute value of the position deviation is the same or less than the setting of Pn522 (Positioning Completed Width) and the reference after the position reference filter is 0.		
	n. 2□□□	Output the /COIN signal when the absolute value of the position deviation is the same or less than the setting of Pn522 (Positioning Completed Width) and the reference input is 0.		

7.2.10 /NEAR (Near) Signal

The /NEAR (Near) signal indicates when positioning completion is being approached.

The host controller receives the NEAR signal before it receives the /COIN (Positioning Completion) signal, it can start preparations for the operating sequence to use after positioning has been completed. This allows you to reduce the time required for operation when positioning is completed.

The NEAR signal is generally used in combination with the /COIN signal.

Type	Signal	Connector Pin No.	Signal Status	Meaning
Output	/NEAR	Must be allocated.	ON (closed)	The Servomotor has reached a point near to positioning completion.
			OFF (open)	The Servomotor has not reached a point near to positioning completion.



You must allocate the /NEAR signal to use it. Use Pn510 = n.□□□X (/NEAR (Near) Signal Allocation) to allocate the signal to a connector pin. Refer to the following section for details.

→ Chap. 7.2.3 'Output Signal Allocations' ...page 190

/NEAR (Near) Signal Setting

You set the condition for outputting the /NEAR (Near) signal (i.e., the near signal width) in Pn524 (Near Signal Width). The /NEAR signal is output when the difference between the reference position and the current position (i.e., the position deviation as given by the value of the deviation counter) is equal to or less than the setting of the near signal width (Pn524).

Near Signal Width

	Setting Range	Setting Unit	Default Setting	When Enabled	Classification
Pn524	1 to 1,073,741,824	1 reference unit	1,073,741,824	Immediately	Setup

(applies to Position Control)

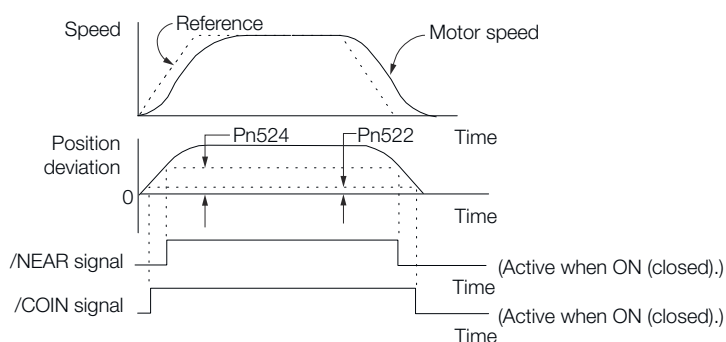


Fig. 149: NEAR (Near) Signal Setting



Normally, set Pn524 to a value that is larger than the setting of Pn522 (Positioning Completed Width).

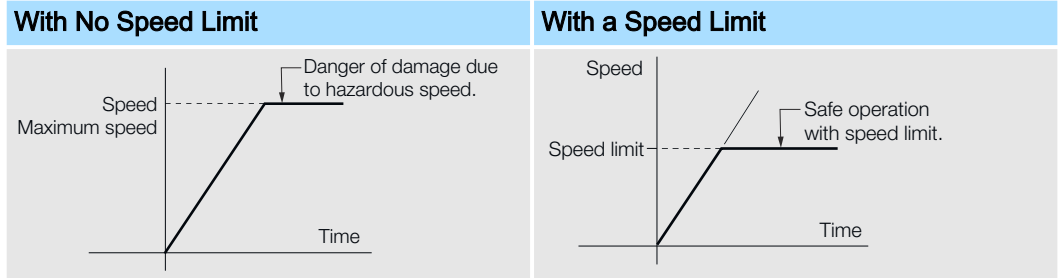
7.2.11 Speed Limit during Torque Control

You can limit the speed of the Servomotor to protect the machine.

When you use a Servomotor for torque control, the Servomotor is controlled to output the specified torque, but the motor speed is not controlled. Therefore, if a reference torque is input that is larger than the machine torque, the speed of the Servomotor may increase greatly. If that may occur, use this function to limit the speed.



The actual limit of motor speed depends on the load conditions on the Servomotor.



/VLT (Speed Limit Detection) Signal

The signal that is output when the motor speed is being limited by the speed limit is described in the following table.

Type	Signal	Connector Pin No.	Signal Status	Meaning
Output	/VLT	Must be allocated.	ON (closed)	The Servomotor speed is being limited.
			OFF (open)	The Servomotor speed is not being limited.



You must allocate the /VLT signal to use it. Use Pn50F = n. □□X□ (/VLT (Speed Limit Detection) Signal Allocation) to allocate the signal to a connector pin. Refer to the following section for details.

→ Chap. 7.2.3 'Output Signal Allocations' ...page 190

Internal Speed Limiting

Set the speed limit for the motor in Pn407 (Speed Limit during Torque Control) or Pn480 (Speed Limit during Force Control). Also set Pn408 = n.□□X□ (Speed Limit Selection) to specify using the maximum motor speed or the overspeed alarm detection speed as the speed limit. Select the overspeed alarm detection speed to limit the speed to the equivalent of the maximum motor speed.

Parameter		Meaning	When Enabled	Classification
Pn408	n.□□0□ (default setting)	Use the smaller of the maximum motor speed and the setting of Pn407 or Pn480 as the speed limit.	After restart	Setup
	n.□□1□	Use the smaller of the overspeed alarm detection speed and the setting of Pn407 or Pn480 as the speed limit.		



If you are using a Rotary Servomotor, set Pn407 (Speed Limit during Torque Control). If you are using a Linear Servomotor, set Pn480 (Speed Limit during Force Control).

- Rotary Servomotors

Speed Limit during Torque Control

	Setting Range	Setting Unit	Default Setting	When Enabled	Classification
Pn407	0 to 10,000	1 min ⁻¹	10000	Immediately	Setup

(applies to Torque Control)

- Linear Servomotors

Speed Limit during Force Control

	Setting Range	Setting Unit	Default Setting	When Enabled	Classification
Pn480	0 to 10,000	1 mm/s	10000	Immediately	Setup

(applies to Force Control)



If the parameter setting exceeds the maximum speed of the Servomotor, the Servomotor's maximum speed or the overspeed alarm detection speed will be used.

7.3 Operation for Momentary Power Interruptions

Even if the main power supply to the SERVOPACK is interrupted momentarily, power supply to the motor (servo ON status) will be maintained for the time set in Pn509 (Momentary Power Interruption Hold Time).

Momentary Power Interruption Hold Time

	Setting Range	Setting Unit	Default Setting	When Enabled	Classification
Pn509	20 to 50,000	1 ms	20	Immediately	Setup

(applies to Speed Control, Position Control and Torque Control)

If the momentary power interruption time is equal to or less than the setting of Pn509, power supply to the motor will be continued. If it is longer than the setting, power supply to the motor will be stopped. Power will be supplied to the motor again when the main circuit power supply recovers.

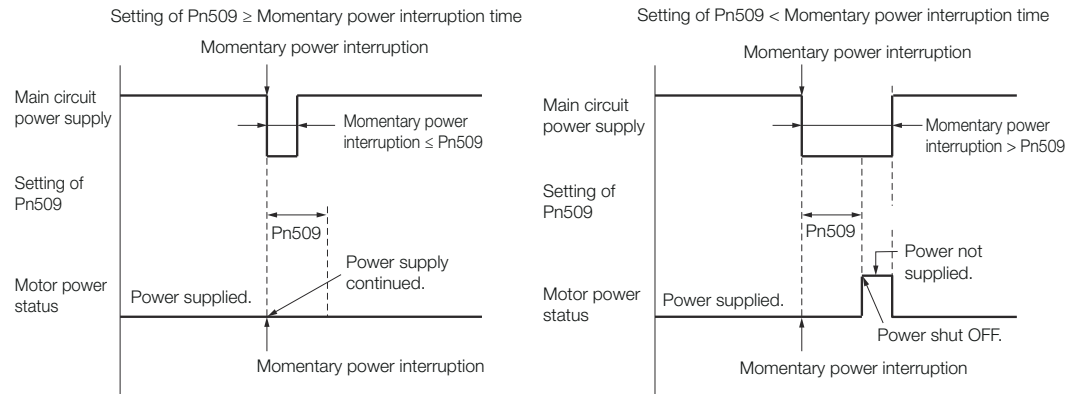


Fig. 150: Pn509 - Momentary Power Interruption Hold Time



- If the momentary power interruption time exceeds the setting of Pn509, the /S-RDY (Servo Ready) signal will turn OFF.
- If uninterruptible power supplies are used for the control power supply and main circuit power supply, the SERVOPACK can withstand a power interruption that lasts longer than 50,000 ms.
- The holding time of the SERVOPACK control power supply is approximately 100 ms. If control operations become impossible during a momentary power interruption of the control power supply, the setting of Pn509 will be ignored and the same operation will be performed as for when the power supply is turned OFF normally.



The holding time of the main circuit power supply depends on the output from the SERVOPACK. If the load on the Servomotor is large and an A.410 alarm (Undervoltage) occurs, the setting of Pn509 will be ignored.

7.4 SEMI F47 Function

The SEMI F47 function detects an A.971 warning (Undervoltage) and limits the output current if the DC main circuit power supply voltage to the SERVOPACK drops to a specified value or lower because the power was momentarily interrupted or the main circuit power supply voltage was temporarily reduced.

This function complies with the SEMI F47 standards for semiconductor manufacturing equipment.

You can combine this function with the momentary power interruption hold time (Pn509) to allow the Servomotor to continue operating without stopping for an alarm or without recovery work even if the power supply voltage drops.

Execution Sequence

This function can be executed either with the host controller or with the SERVOPACK. Use Pn008 = n.□□X□ (Function Selection for Undervoltage) to specify whether the function is executed by the host controller or by the SERVOPACK.

The default setting (Pn008 = n.□□0□) disables detection of an A.971 warning (Undervoltage).

Parameter	Meaning	When Enabled	Classification
Pn008	n.□□0□ (default setting)	After restart	Setup
	n.□□1□		
	n.□□2□		

■ Execution with the Host Controller (Pn008 = n.□□1□)

The host controller limits the torque in response to an A.971 warning (Undervoltage). The host controller removes the torque limit after the Undervoltage warning is cleared.

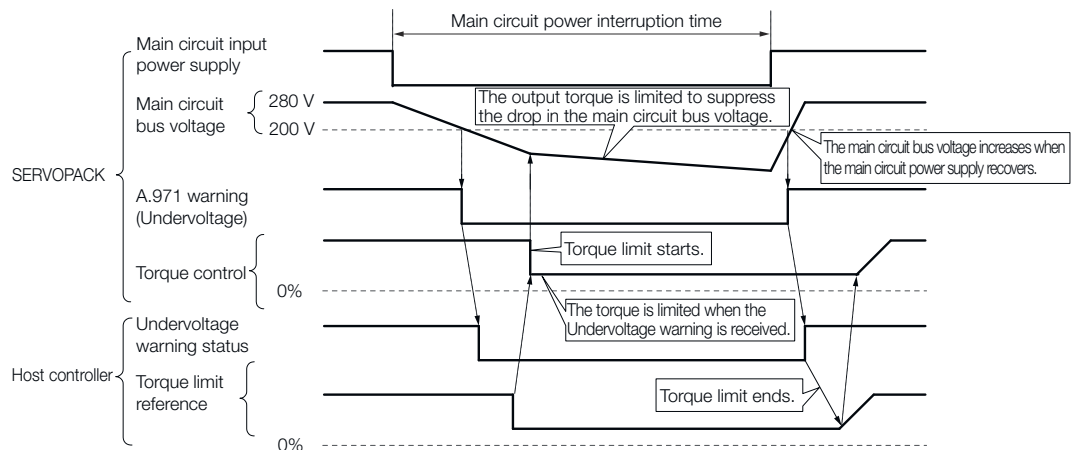


Fig. 151: SEMI F47 Function - Execution with the Host Controller

■ Execution with the SERVOPACK (Pn008 = n.□□2□)

The torque is limited in the SERVOPACK in response to an Undervoltage warning. The SERVOPACK controls the torque limit for the set time after the Undervoltage warning is cleared.

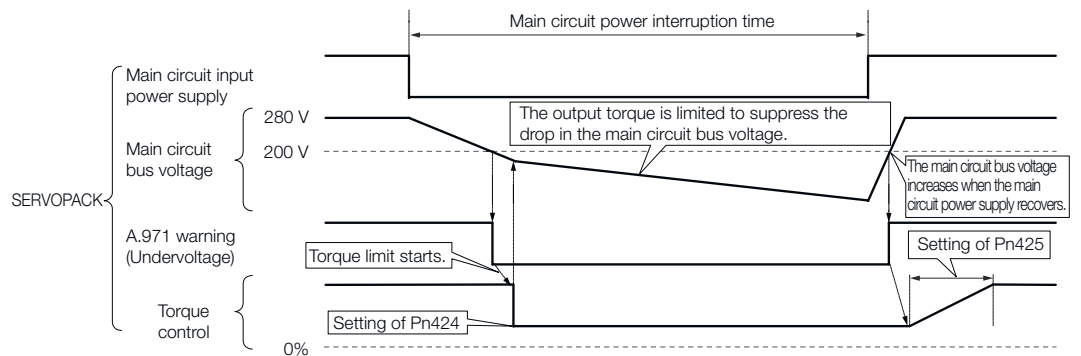


Fig. 152: SEMI F47 Function - Execution with the SERVOPACK

Related Parameters

The following parameters are related to the SEMI F47 function.

Torque Limit at Main Circuit Voltage Drop

	Setting Range	Setting Unit	Default Setting	When Enabled	Classification
Pn424	0 to 100	1%*	50	Immediately	Setup

(applies to Speed Control, Position Control and Torque Control)

Release Time for Torque Limit at Main Circuit Voltage Drop

	Setting Range	Setting Unit	Default Setting	When Enabled	Classification
Pn425	0 to 1,000	1 ms	100	Immediately	Setup

(applies to Speed Control, Position Control and Torque Control)

Momentary Power Interruption Hold Time

	Setting Range	Setting Unit	Default Setting	When Enabled	Classification
Pn509	20 to 50,000	1 ms	20	Immediately	Setup

(applies to Speed Control, Position Control and Torque Control)

* Set a percentage of the motor rated torque.



If you will use the SEMI F47 function, set the time to 1,000 ms.



- *This function handles momentary power interruptions for the voltage and time ranges stipulated in SEMI F47. An uninterruptible power supply (UPS) is required as a backup for momentary power interruptions that exceed these voltage and time ranges.*
- *Set the host controller or SERVOPACK torque limit so that a torque reference that exceeds the specified acceleration torque will not be output when the power supply for the main circuit is restored.*
- *For a vertical axis, do not limit the torque to a value that is lower than the holding torque.*
- *This function limits torque within the range of the SERVOPACK's capability for power interruptions. It is not intended for use under all load and operating conditions. Set the parameters while monitoring operation on the actual machine.*
- *You can set the momentary power interruption hold time to increase the amount of time from when the power supply is turned OFF until power supply to the motor is stopped. To stop the power supply to the motor immediately, use the Servo OFF command (Disable Operation command).*

7.5 Setting the Motor Maximum Speed

You can set the maximum speed of the Servomotor with the following parameter.

- Rotary Servomotors

Maximum Motor Speed

	Setting Range	Setting Unit	Default Setting	When Enabled	Classification
Pn316	0 to 65,535	1 min ⁻¹	10,000	After restart	Setup

(applies to Speed Control, Position Control and Torque Control)

- Linear Servomotors

Maximum Motor Speed

	Setting Range	Setting Unit	Default Setting	When Enabled	Classification
Pn385	1 to 100	100 mm/s	50	After restart	Setup

(applies to Speed Control, Position Control and Force Control)

You can achieve the following by lowering the maximum speed of the Servomotor.

- If the Servomotor speed exceeds the setting, an A.510 alarm (Overspeed) will occur.
- With a Linear Servomotor, you can increase the upper limit for the setting of Pn281 (Encoder Output Resolution). Refer to the following section for details.

➔ [Chap. 7.6.1 'Encoder Divided Pulse Output' ...page 204](#)

Changing the setting of the parameter is effective in the following cases.

- To protect the machine by stopping machine operation with an alarm when the set speed is reached or exceeded
- To limit the speed so that the load is driven beyond the allowable moment of inertia
Refer to relevant manual from the following list for the relationship between the speed and the allowable moment of inertia.
 - 📖 [Σ-7-Series Rotary Servomotor Product Manual \(Manual No.: SIEP S800001 36\)](#)
 - 📖 [Σ-7-Series Direct Drive Servomotor Product Manual \(Manual No.: SIEP S800001 38\)](#)
 - 📖 [Σ-7-Series Linear Servomotor Product Manual \(Manual No.: SIEP S800001 37\)](#)
- To increase the encoder output resolution and increase the position resolution managed by the host controller (for a Linear Servomotor)

7.6 Encoder Divided Pulse Output

7.6.1 Overview

The encoder divided pulse output is a signal that is output from the encoder and processed inside the SERVOPACK. It is then output externally in the form of two phase pulse signals (phases A and B) with a 90° phase differential. At the host controller, it is used as the position feedback.

The following table describes the signals and output phase forms.

7.6.2 Encoder Divided Pulse Output Signals

Type	Signal	Connector Pin No.	Name	Remarks
Output	PAO	CN1-17	Encoder Divided Pulse Output, Phase A	<ul style="list-style-type: none"> ■ Rotary Servomotors These encoder divided pulse output pins output the number of pulses per Servomotor resolution
	/PAO	CN1-18		

Type	Signal	Connector Pin No.	Name	Remarks
	PBO	CN1-19	Encoder Divided Pulse Output, Phase B	that is set in Pn212 (Number of Encoder Output Pulses). The phase difference between phase A and phase B is an electric angle of 90°. <ul style="list-style-type: none"> Linear Servomotors These encoder divided pulse output pins output pulses at the resolution that is set in Pn281 (Encoder Output Resolution). The phase difference between phase A and phase B is an electric angle of 90°.
	/PBO	CN1-20		
	PCO	CN1-21	Encoder Divided Pulse Output, Phase C*	These pins output one pulse every motor rotation.
	/PCO	CN1-22		

* Refer to the following section for information on the origin within one encoder rotation.

➔ [Chap. 7.6.2 'Encoder Divided Pulse Output Signals' ...page 204](#)

■ Rotary Servomotor

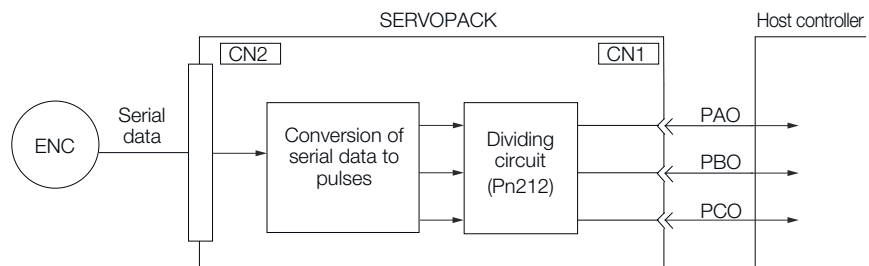


Fig. 153: Encoder Signal Output - Rotary Servomotor

■ Linear Servomotors

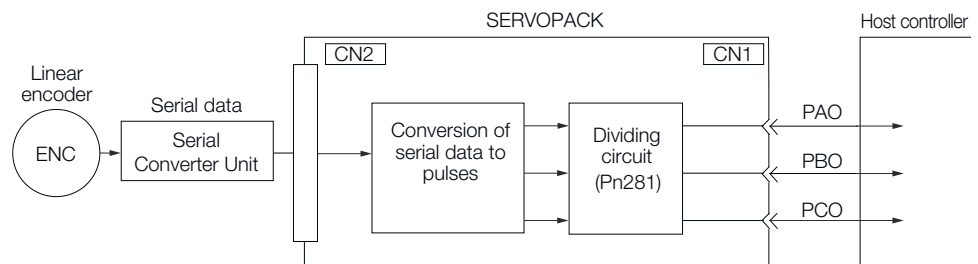
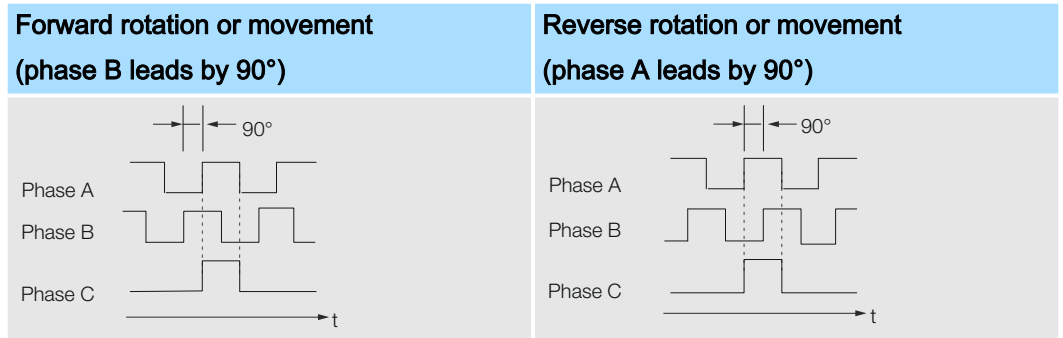


Fig. 154: Encoder Signal Output - Linear Servomotor

Output Phase Forms



The pulse width of the origin within one encoder rotation depends on the setting of number of encoder output pulses (Pn212) or the encoder output resolution (Pn281). It is the same as the width of phase A. Even for reverse operation (Pn000 = n.□□□1), the output phase form is the same as shown above.



If you use the SERVOPACK's phase-C pulse output for an origin return, rotate the Servomotor two or more rotations before you start an origin return. If the Servomotor cannot be rotated two or more times, perform an origin return operation at a motor speed of 600 min⁻¹ or lower. If the motor speed is higher than 600 min⁻¹, the phase-C pulse may not be output correctly.

Linear Encoder Application Precautions

The following precautions apply to the encoder output pulses when an external linear encoder is used.

Relation between Renishaw PLC Incremental Linear Encoders and Encoder Output Pulse Signal from the SERVOPACK when using a RGS20 Scale and RGH22B Sensor Head

The output position of the origin signal (Ref) will depend on the direction of movement for some models of incremental linear encoders from Renishaw PLC.

In that case, the phase-C pulse of the SERVOPACK is output at two positions.

For detailed specifications on the origin signal, refer to the manual for the Renishaw PLC incremental linear encoder.

- When passing the first Origin signal (Ref) in the forward direction and returning after turning ON the power supply

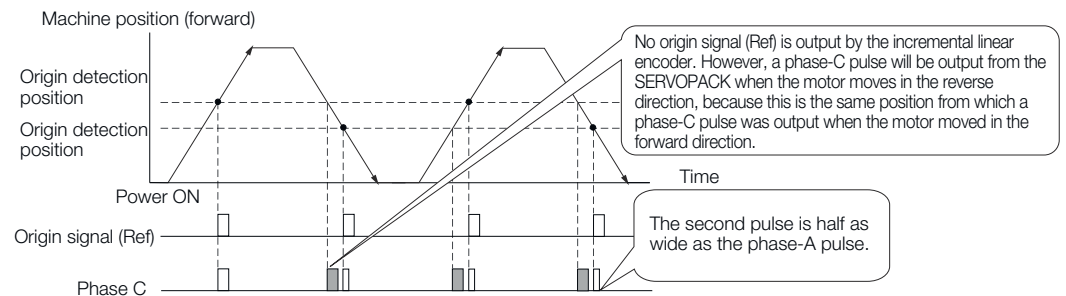


Fig. 155: Renishaw Incremental Linear Encoder - When passing the first Origin Signal (Ref) in the forward direction

- When passing the first Origin signal (Ref) in the reverse direction and returning after turning ON the power supply

Encoder Divided Pulse Output > Encoder Divided Pulse Output Signals

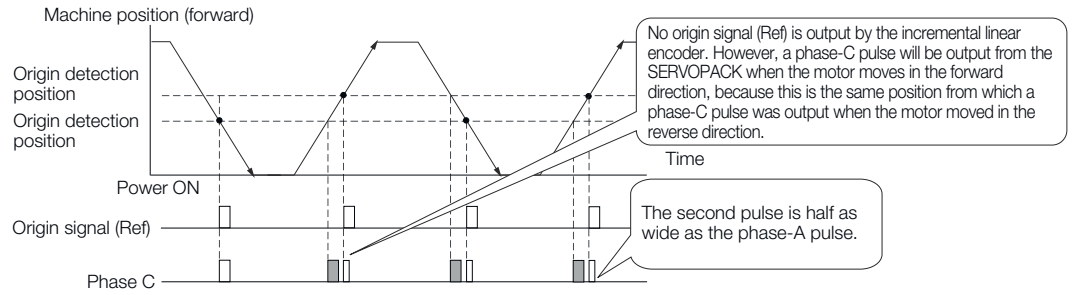


Fig. 156: Renishaw Incremental Linear Encoder - When passing the first Origin signal (Ref) in the reverse direction

Precautions When Using a Linear Incremental Encoder from Magnescale Co., Ltd.

■ Encoder Divided Phase-C Pulse Output Selection

You can also output the encoder's phase-C pulse for reverse movement. To do so, set Pn081 to n.□□□1.

Parameter	Meaning	When Enabled	Classification
Pn081	n.□□□0 (default setting)	After restart	Setup
	n.□□□1		



Precautions on Setting the Phase-C Pulse Output Selection (Pn081 = n.□□□X)

- If you set Pn081 to n.□□□1 (Output phase-C pulses in both the forward and reverse directions), the width of the phase-C pulse output may be narrower than the width of the phase-A pulse.
- There is a difference of 1/8th of the scale pitch in the phase-C detection position for the encoder's phase-C pulse output position, origin return command, or phase-C latch between when Pn081 = n.□□□X is set to 0 (Output phase-C pulses only in the forward direction) and when it is set to 1 (Output phase-C pulses in both the forward and reverse directions).

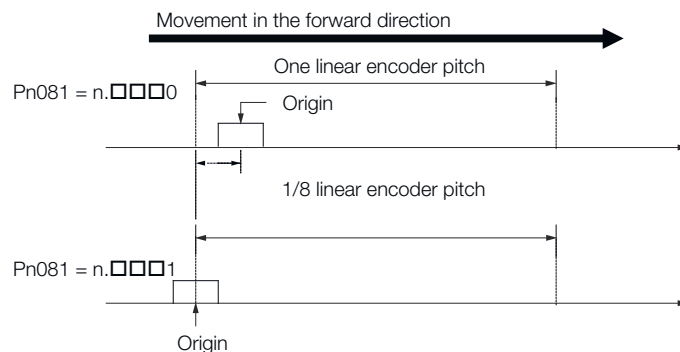


Fig. 157: Pn081 - Phase-C Pulse Output Selection

Observe the following precaution if you set Pn081 to n.□□□0 (Output phase-C pulses only in the forward direction).

When a linear incremental encoder from Magnescale Co., Ltd. is used, the count direction of the encoder determines how the phase-C pulse (CN1-21 and CN1-22) is output.



The count direction (up or down) of the linear encoder determines whether a phase-C pulse is output. The output of the pulse does not depend on the setting of the movement direction (Pn000 = n.□□□1).

Encoder Model	Interpolator	Linear Encoder Pitch [μm]
SL710	PL101-RY	800
SL720	MJ620-T13	800
SL730		800
SR75		80
SR85		80
SQ10	MQ10-FLA	400
	MQ10-GLA	

- When first passing the Origin signal in the forward direction and returning after turning ON the power supply

The encoder's phase-C pulse (CN1-21 and CN1-22) is output when the origin detection position is passed for the first time in the forward direction after the power supply is turned ON.

After that, the phase-C pulse is output whenever the origin detection position is passed in the forward or reverse direction.

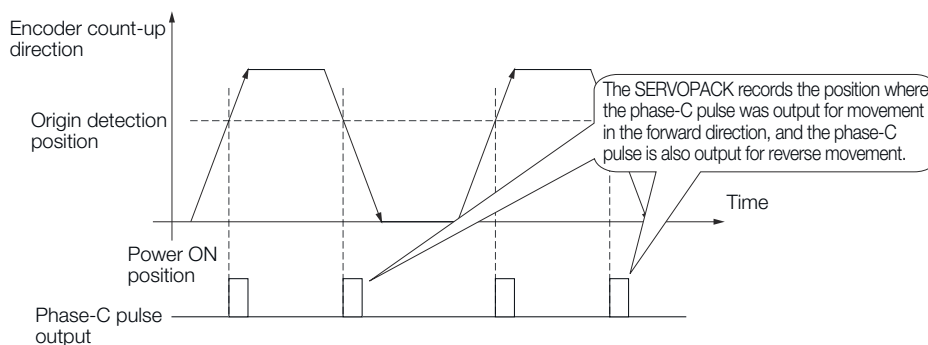


Fig. 158: Magnescape Linear Incremental Encoder - When First passing the Origin signal in the forward direction

- When first passing the Origin signal in the reverse direction and returning after turning ON the power supply

The encoder's phase-C pulse (CN1-19 and CN1-20) is not output when the origin detection position is passed for the first time in the reverse direction after the power supply is turned ON.

However, after the origin detection position is passed in the forward direction and the encoder's phase-C pulse is output, it will then also be output when the origin detection point is passed in the reverse direction.

Encoder Divided Pulse Output > Encoder Divided Pulse Output Signals

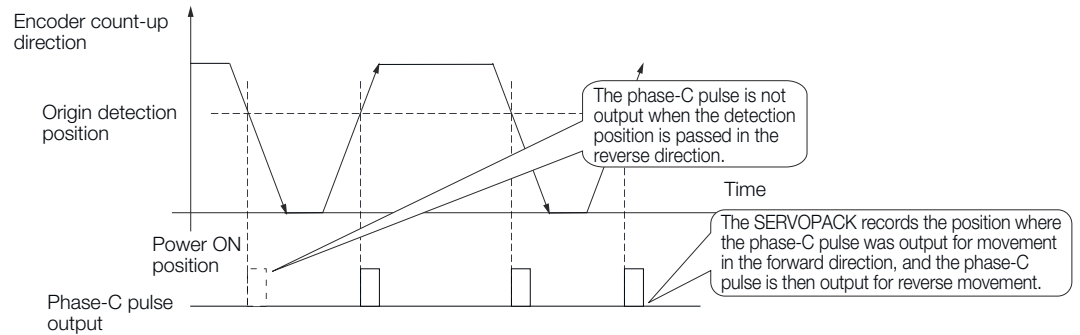


Fig. 159: Magnescale Linear Incremental Encoder - When first passing the Origin signal in the reverse direction

- When using a Linear encoder with multiple origins and first passing the Origin position in the forward direction and returning after turning ON the power supply

The encoder's phase-C pulse is output when the origin detection position is passed for the first time in the forward direction after the power supply is turned ON. After that, the phase-C pulse is output whenever the origin detection position is passed in the forward or reverse direction.

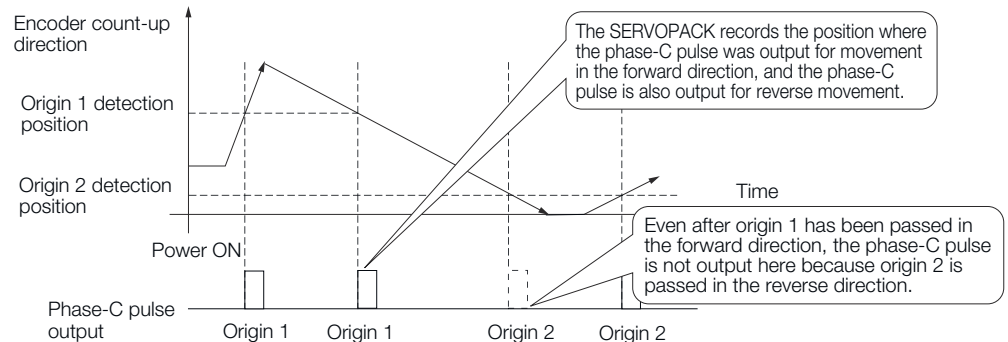


Fig. 160: Magnescale Linear Incremental Encoder - When using a Linear encoder with multiple origins and first passing the Origin position in the forward direction

- When using a Linear encoder with multiple origins and first passing the Origin position in the reverse direction after turning ON the power supply

The encoder's phase-C pulse is not output when the origin detection position is passed for the first time in the reverse direction after the power supply is turned ON.

However, after the origin detection position is passed in the forward direction and the encoder's phase-C pulse it output, it will then also be output when the origin detection point is passed in the reverse direction.

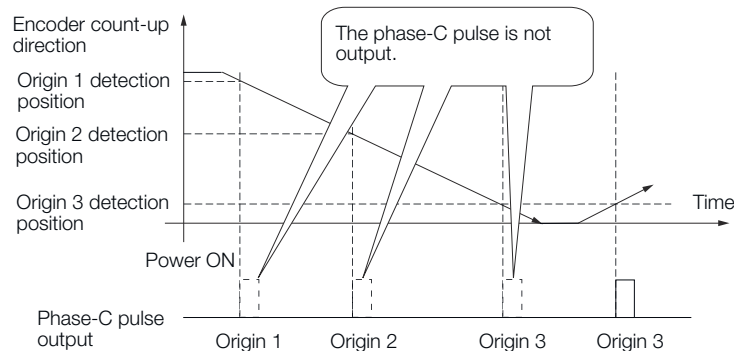


Fig. 161: Magnescale Linear Incremental Encoder - When using a Linear encoder with multiple origins and first passing the Origin position in the reverse direction

7.6.3 Setting for the Encoder Divided Pulse Output

This section describes the setting for the encoder divided pulse output for a Rotary Servomotor or Linear Servomotor.

Encoder Divided Pulse Output When Using a Rotary Servomotor

If you will use a Rotary Servomotor, set the number of encoder output pulses (Pn212).

Number of Encoder Output Pulses

	Setting Range	Setting Unit	Default Setting	When Enabled	Classification
Pn212	16 to 1,073,741,824	1 P/Rev	2,048	After restart	Setup

(applies to Speed Control, Position Control and Torque Control)

The number of pulses from the encoder per rotation are processed inside the SERVOPACK, divided by the setting of Pn212, and then output.

Set the number of encoder divided output pulses according to the system specifications of the machine or host controller.

The setting of the number of encoder output pulses is limited by the resolution of the encoder.

Setting of the Number of Encoder Output Pulses [P/Rev]	Setting Increment	Encoder Resolution			Upper Limit of Servomotor Speed for Set Number of Encoder Output Pulses [min ⁻¹]
		20 bits (1,048,576 pulses)	22 bits (4,194,304 pulses)	24 bits (16,777,216 pulses)	
16 to 16,384	1	○	○	○	6,000
16,386 to 32,768	2	○	○	○	3,000
32,772 to 65,536	4	○	○	○	1,500
65,544 to 131,072	8	○	○	○	750
131,088 to 262,144	16	○	○	○	375
262,176 to 524,288	32	–	○	○	187
524,352 to 1,048,576	64	–	○	○	93
1,048,704 to 2,097,152	128	–	–	○	46
2,097,408 to 4,194,304	256	–	–	○	23



- The setting range of the number of encoder output pulses (Pn212) depends on the resolution of the Servomotor encoder. An A.041 alarm (Encoder Output Pulse Setting Error) will occur if the above setting conditions are not met.
Correct setting example: Pn212 can be set to 25,000 [P/Rev].
Incorrect setting example: Pn212 cannot be set to 25,001 (P/Rev) because the setting increment in the above table is not used.
- The upper limit of the pulse frequency is approximately 1.6 Mpps (Million Pulses per Second). The Servomotor speed will be limited if the setting of the number of encoder output pulses is too high.
An A.511 alarm (Encoder Output Pulse Overspeed) will occur if the upper limit of the motor speed is exceeded.

Output example

An output example is given below for the PAO (Encoder Pulse Output Phase A) signal and the PBO (Encoder Pulse Output Phase B) signal when Pn212 is set to 16 (16 pulses output per revolution).

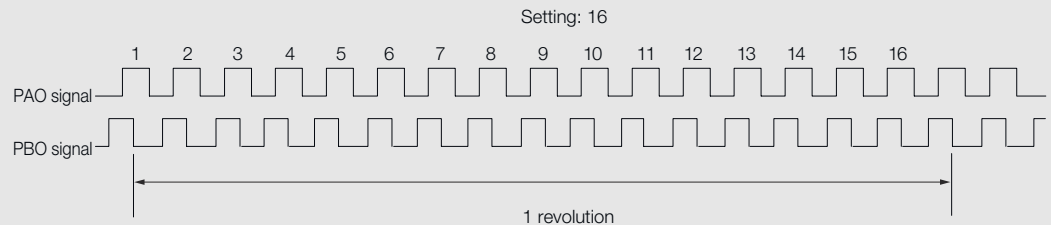


Fig. 162: Encoder Divided Pulse Output Example

Encoder Divided Pulse Output When Using a Linear Servomotor

If you will use a Linear Servomotor, set the encoder output resolution (Pn281).

Encoder Output Resolution

	Setting Range	Setting Unit	Default Setting	When Enabled	Classification
Pn281	1 to 4,096	1 edge/pitch	20	After restart	Setup

(applies to Speed Control, Position Control and Force Control)



The maximum setting for the encoder output resolution is 4,096. Pulse output at a linear encoder resolution of 4,096 or higher is not possible.

Set the encoder output resolution for the encoder pulse output signals (PAO, /PAO, PBO, and /PBO) from the SERVOPACK to the host controller.

The number of feedback pulses per linear encoder pitch is divided by the setting of Pn281 (after multiplication by 4) inside the SERVOPACK and then the resulting number of pulses is output. Set the parameter according to the system specifications of the machine or host controller.

The setting range depends on the Servomotor's maximum speed (Pn385) and the linear scale pitch (Pn282).* You can calculate the upper limit of the setting of Pn281 with the following formula.

$$\text{Upper limit of Pn281} = \frac{\text{Linear Encoder Pitch} * 100}{\text{Pn385}} \times 72$$

Fig. 163: Upper limit of the setting of Pn281 - Formula

* The value depends on whether a Serial Converter Unit is used.

Using a Serial Converter Unit	Setting of Pn282
Not Using a Serial Converter Unit (when the linear encoder and SERVOPACK are connected directly or when a linear encoder that does not require a Serial Converter Unit is used)	The linear encoder pitch is automatically detected by the SERVOPACK, so the setting of Pn282 is ignored. You can use the monitor functions of the SigmaWin+ to check the linear encoder pitch that was automatically detected.



When the linear encoder pitch is 4 μm , the maximum motor speed is limited to 1 mm/s because of the maximum response frequency of the Serial Converter Unit.

If the setting is out of range or does not satisfy the setting conditions, an A.041 alarm (Encoder Output Pulse Setting Error) will be output. If the motor speed exceeds the upper limit for the set encoder output resolution, an A.511 alarm (Encoder Output Pulse Overspeed) will be output.

The upper limit of the encoder output resolution is restricted by the dividing specifications of the Serial Converter Unit.

Setting Example

Correct setting for a linear encoder pitch of 20 μm and a maximum motor speed of 5 m/s (Pn385 = 50): Pn281 = 28 (edges/pitch)

Incorrect setting: Pn281 = 29 (edges/pitch) (An A.041 alarm would be output.)

Pulse Output Example

When Pn281 = 20 (20-edge output (5-pulse output) per linear encoder pitch)

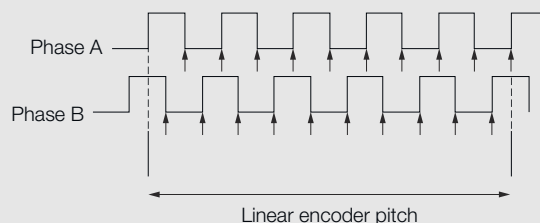


Fig. 164: Pulse Output Example - Pn281

7.7 Software Limits

You can set limits in the software for machine movement that do not use the overtravel signals (P-OT and N-OT). If a software limit is exceeded, an emergency stop will be executed in the same way as it is for overtravel.

Refer to the following section for details on this function.

➔ [Chap. 15.7 'PROFIdrive Position Mode' ...page 523](#)

7.8 Selecting Torque Limits

7.8.1 Overview

You can limit the torque that is output by the Servomotor.

There are four different ways to limit the torque. These are described in the following table.

Limit Method	Outline	Control Method	Reference
Internal Torque Limits	The torque is always limited with the setting of a parameter.	Speed control, position control, or torque control	↪ Chap. 7.8.2 'Internal Torque Limits' ...page 213
External Torque Limits	The torque is limited with an input signal from the host computer.		↪ Chap. 7.8.3 'External Torque Limits' ...page 214
Limiting Torque with <i>controlword</i> (6040h)	A command from the Controller enables the torque limit that is set in a parameter.		↪ Chap. 15.6 'Device Control' ...page 512
Limiting Torque with <i>positive torque limit value</i> (60E0h), <i>negative torque limit value</i> (60E1h), and <i>max. torque</i> (6072h)	Torque is controlled with torque limits from the Controller.		↪ Chap. 14.7 'Torque Limits' ...page 487



If you set a value that exceeds the maximum torque of the Servomotor, the torque will be limited to the maximum torque of the Servomotor.

7.8.2 Internal Torque Limits

If you use internal torque limits, the maximum output torque will always be limited to the specified Forward Torque Limit (Pn402) and Reverse Torque Limit (Pn403).

Rotary Servomotors

Forward Torque Limit

	Setting Range	Setting Unit	Default Setting	When Enabled	Classification
Pn402	0 to 800	1%*	800	Immediately	Setup

(applies to Speed Control, Position Control and Torque Control)

Reverse Torque Limit

	Setting Range	Setting Unit	Default Setting	When Enabled	Classification
Pn403	0 to 800	1%*	800	Immediately	Setup

(applies to Speed Control, Position Control and Torque Control)

* Set a percentage of the rated motor torque.



If the setting of Pn402 or Pn403 is too low, the torque may be insufficient for acceleration or deceleration of the Servomotor.

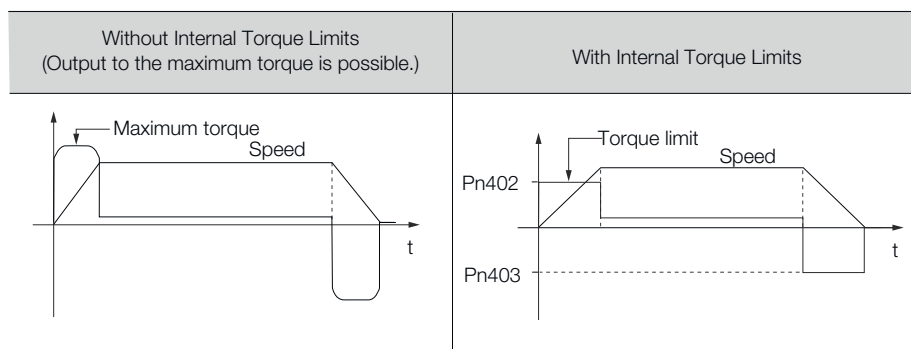


Fig. 165: Internal Torque Limits - Rotary Servomotors

Linear Servomotors

Forward Force Limit

	Setting Range	Setting Unit	Default Setting	When Enabled	Classification
Pn483	0 to 800	1%*	30	Immediately	Setup

(applies to Speed Control, Position Control and Force Control)

Reverse Force Limit

	Setting Range	Setting Unit	Default Setting	When Enabled	Classification
Pn484	0 to 800	1%*	30	Immediately	Setup

(applies to Speed Control, Position Control and Force Control)

* Set a percentage of the rated motor force.



If the setting of Pn483 or Pn484 is too low, the force may be insufficient for acceleration or deceleration of the Servomotor.

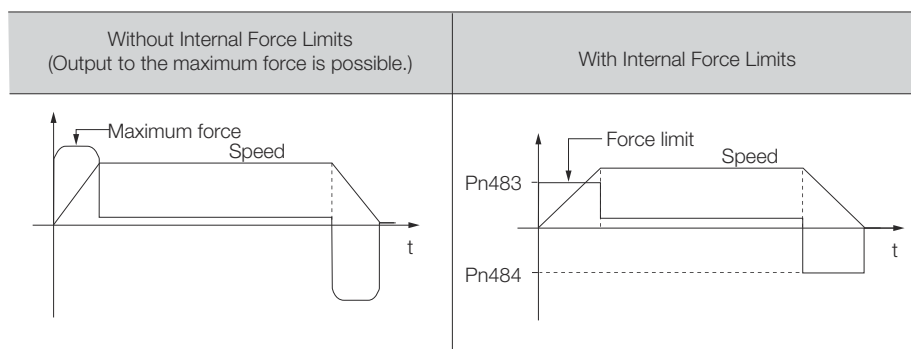


Fig. 166: Internal Force Limits - Linear Servomotors

7.8.3 External Torque Limits

You can limit the torque only when required by the operating conditions of the machine by turning a signal ON and OFF.

You can use this for applications such as stopping on physical contact, or holding a workpiece with a robot.

External Torque Limit Reference Signals

The /P-CL (Forward External Torque Limit) and /N-CL (Reverse External Torque Limit) signals are used as the external torque limit reference signals. The /P-CL signal is used for the forward torque limit and the /N-CL signal is used for the reverse torque limit.

Type	Signal	Connector Pin No.	Signal Status	Meaning
Input	/P-CL	Must be allocated.	ON (closed)	Applies the forward external torque limit. The torque is limited to the smaller of the settings of Pn402* ¹ and Pn404.
			OFF (open)	Cancels the forward external torque limit. The torque is limited to the setting of Pn402* ¹ .
Input	/N-CL	Must be allocated.	ON (closed)	Applies the reverse external torque limit. The torque is limited to the smaller of the settings of Pn403* ² and Pn405.
			OFF (open)	Cancels the reverse external torque limit. The torque is limited to the setting of Pn403* ² .

*1. Pn483 is used for a Linear Servomotor.

*2. Pn484 is used for a Linear Servomotor.



You must allocate the /P-CL and /N-CL signals to use them. You can use the following parameters to allocate the signal to a terminal.

- Pn50B = n.□X□□□ (/P-CL (Forward External Torque Limit Input) Signal Allocation)
- Pn50B = n.X□□□□ (/N-CL (Reverse External Torque Limit Input) Signal Allocation)

Refer to the following section for details.

→ [Chap. 7.2.2 'Input Signal Allocations' ...page 189](#)

Setting the Torque Limits

The parameters that are related to setting the torque limits are given below.

Rotary Servomotors

If the setting of Pn402 (Forward Torque Limit), Pn403 (Reverse Torque Limit), Pn404 (Forward External Torque Limit), or Pn405 (Reverse External Torque Limit) is too low, the torque may be insufficient for acceleration or deceleration of the Servomotor.

Selecting Torque Limits > External Torque Limits

Forward Torque Limit

	Setting Range	Setting Unit	Default Setting	When Enabled	Classification
Pn402	0 to 800	1%*	800	Immediately	Setup

(applies to Speed Control, Position Control and Torque Control)

Reverse Torque Limit

	Setting Range	Setting Unit	Default Setting	When Enabled	Classification
Pn403	0 to 800	1%*	800	Immediately	Setup

(applies to Speed Control, Position Control and Torque Control)

Forward External Torque Limit

	Setting Range	Setting Unit	Default Setting	When Enabled	Classification
Pn404	0 to 800	1%*	100	Immediately	Setup

(applies to Speed Control, Position Control and Torque Control)

Reverse External Torque Limit

	Setting Range	Setting Unit	Default Setting	When Enabled	Classification
Pn405	0 to 800	1%*	100	Immediately	Setup

(applies to Speed Control, Position Control and Torque Control)

* Set a percentage of the rated motor torque.

Linear Servomotors

If the setting of Pn483 (Forward Force Limit), Pn484 (Reverse Force Limit), Pn404 (Forward External Force Limit), or Pn405 (Reverse External Force Limit) is too low, the force may be insufficient for acceleration or deceleration of the Servomotor.

Forward Force Limit

	Setting Range	Setting Unit	Default Setting	When Enabled	Classification
Pn483	0 to 800	1%*	30	Immediately	Setup

(applies to Speed Control, Position Control and Force Control)

Reverse Force Limit

	Setting Range	Setting Unit	Default Setting	When Enabled	Classification
Pn484	0 to 800	1%*	30	Immediately	Setup

(applies to Speed Control, Position Control and Force Control)

Forward External Force Limit

	Setting Range	Setting Unit	Default Setting	When Enabled	Classification
Pn404	0 to 800	1%*	100	Immediately	Setup

(applies to Speed Control, Position Control and Force Control)

Reverse External Force Limit

	Setting Range	Setting Unit	Default Setting	When Enabled	Classification
Pn405	0 to 800	1%*	100	Immediately	Setup

(applies to Speed Control, Position Control and Force Control)

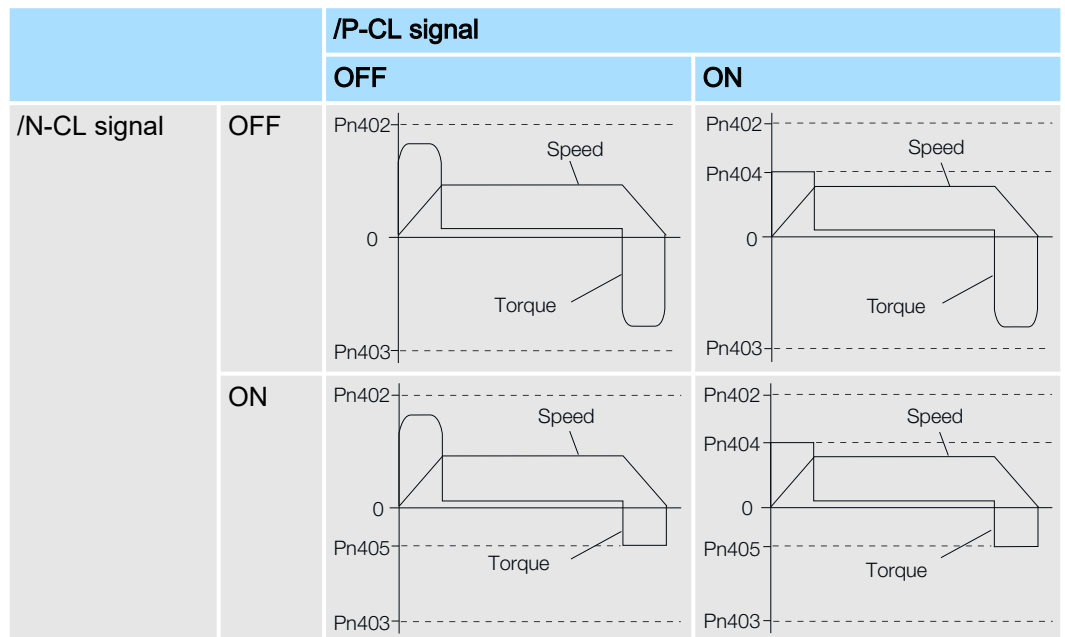
* Set a percentage of the rated motor force.

Changes in the Output Torque for External Torque Limits

The following table shows the changes in the output torque when the internal torque limit is set to 800%.

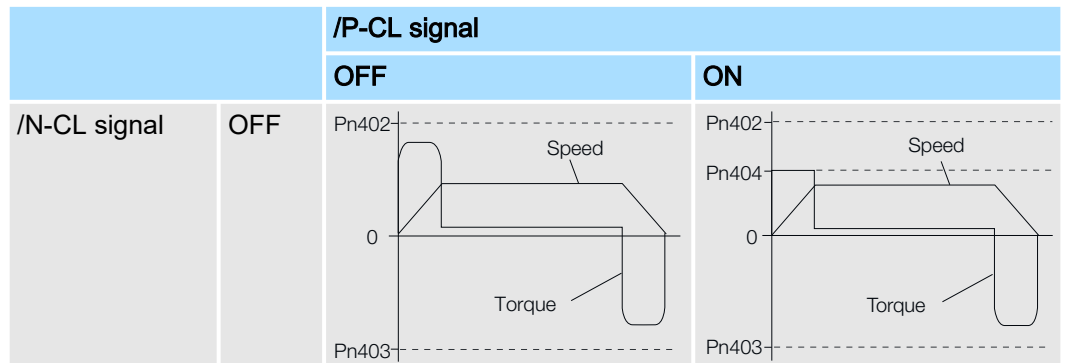
■ Rotary Servomotors

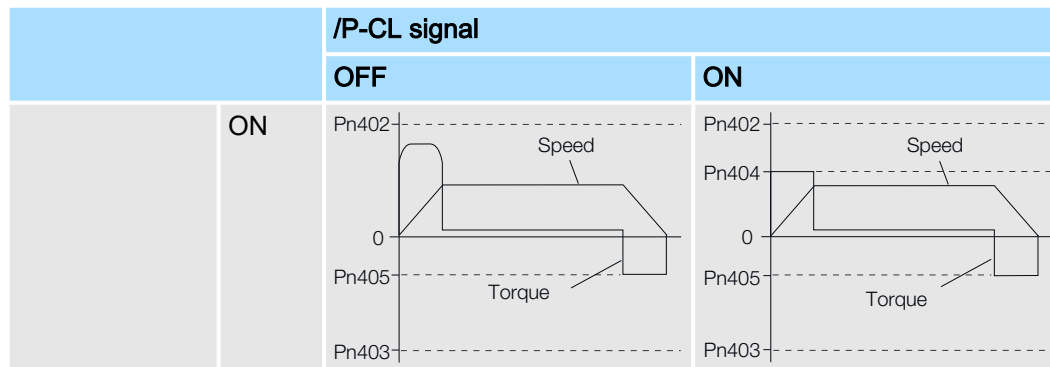
It is assumed that counterclockwise is set as the forward direction of motor rotation (Pn000 = n.□□□0).



■ Linear Servomotors

It is assumed that the linear encoder count-up direction is set as the forward direction of motor movement (Pn000 = n.□□□0).





7.8.4 /CLT (Torque Limit Detection) Signal

This section describes the /CLT signal, which indicates the status of limiting the motor output torque.

Type	Signal	Connector Pin No.	Signal Status	Meaning
Output	/CLT	Must be allocated.	ON (closed)	The motor output torque is being limited.
			OFF (open)	The motor output torque is not being limited.



You must allocate the /CLT signal to use it. Use Pn50F = n.□□□X (/CLT (Torque Limit Detection) Signal Allocation) to allocate the signal to a connector pin. Refer to the following section for details.

→ Chap. 7.2.3 'Output Signal Allocations' ...page 190

7.9 Absolute Encoders

7.9.1 Overview

The absolute encoder records the current position of the stop position even when the power supply is OFF.

With a system that uses an absolute encoder, the host controller can monitor the current position. Therefore, it is not necessary to perform an origin return operation when the power supply to the system is turned ON.

There are four types of encoders for Rotary Servomotors. The usage of the encoder is specified in Pn002 = n.□X□□.

SERVOPACKs with software version 0023 or higher support batteryless absolute encoders.

Refer to the following section for encoder models.

→ 'Calculating the Settings for the Electronic Gear Ratio' ...page 173

Parameter Settings When Using an Incremental Encoder

Parameter	Meaning	When Enabled	Classification	
Pn002	n.□0□□ (default setting)	Use the encoder as an incremental encoder. A battery is not required.	After restart	Setup

Parameter	Meaning	When Enabled	Classification
n.□1□□	Use the encoder as an incremental encoder. A battery is not required.		

Parameter Settings When Using a Single-Turn Absolute Encoder

Parameter	Meaning	When Enabled	Classification
Pn002	n.□0□□ (default setting)	After restart	Setup
	n.□1□□		

Parameter Settings When Using a Multiturn Absolute Encoder

Parameter	Meaning	When Enabled	Classification
Pn002	n.□0□□ (default setting)	After restart	Setup
	n.□1□□		
	n.□2□□		

Parameter Settings When Using a Batteryless Multiturn Absolute Encoder

Parameter	Meaning	When Enabled	Classification
Pn002	n.□0□□ (default setting)	After restart	Setup
	n.□1□□		
	n.□2□□		



NOTICE

Install a battery at either the host controller or on the Encoder Cable.

If you install batteries both at the host controller and on the Encoder Cable at the same time, you will create a loop circuit between the batteries, resulting in a risk of damage or burning.

7.9.2 Connecting an Absolute Encoder

You can get the position data from the absolute encoder with PROFINET communications. Therefore, it is not necessary to wire the PAO, PBO, and PCO (Encoder Divided Pulse Output) signals.

If they need to be wired, refer to the following section.

→ Chap. 5.5.3.1 'Wiring the SERVOPACK to the Encoder' ...page 106

→ Chap. 5.6.3 'I/O Signal Wiring Examples' ...page 117

7.9.3 Structure of the Position Data of the Absolute Encoder

The position data of the absolute encoder is the position coordinate from the origin of the absolute encoder.

If you use the encoder divided pulse output (PAO, PBO, and PCO) signals to get the position information, the position data from the absolute encoder contains the following two items.

- The number of rotations from the origin of the encoder coordinate system (called the multiturn data)
- The position (number of pulses) within one rotation

The position data of the absolute encoder is as follows:

Position data of absolute encoder = Multiturn data × Number of pulses within one encoder rotation (setting of Pn212) + Position (number of pulses) within one rotation.

For a single-turn absolute encoder, the multiturn data is 0.

7.9.4 Output Ports for the Position Data from the Absolute Encoder

You can read the position data of the absolute encoder from the PAO, PBO, and PCO (Encoder Divided Pulse Output) signals.

The output method and timing for the position data of the absolute encoder are different in each case.

A conceptual diagram of the connections of the PAO, PBO, and PCO (Encoder Divided Pulse Output) signals to the host controller is provided below.

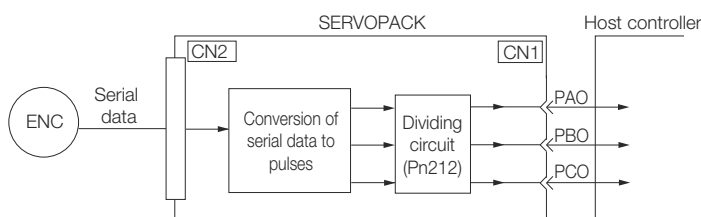


Fig. 167: Encoder Divided Pulse Output Signals to the Host Controller

Signal	Status	Signal Contents
		When Using an Absolute Encoder
PAO	First signal	Multiturn data position within one rotation (pulse train)
	During normal operation	Incremental pulses
PBO	First signal	Position within one rotation (pulse train)
	During normal operation	Incremental pulses
PCO	Always	Origin pulse

The PAO (Encoder Divided Pulse Output) signal outputs the position data from the absolute encoder after the control power supply is turned ON.

The position data of the absolute encoder is the current stop position. The absolute encoder outputs the multiturn data with the specified protocol. The absolute encoder outputs the position within one rotation as a pulse train. It then outputs pulses as an incremental encoder (incremental operation status).

The host controller must have a reception circuit (e.g., UART) for the position data from the absolute encoder. The pulse counter at the host controller will not count pulses when the multiturn data (communications message) is input because only phase A is input. Counting starts from the position of the absolute encoder within one rotation.

The output circuits for the PAO, PBO, and PCO signals use line drivers. Refer to the following section for details on line drivers.

→ Chap. 5.6.4 'I/O Circuits' ...page 119

7.9.5 Reading the Position Data from the Absolute Encoder

The sequence to read the position data from the absolute encoder of a Rotary Servomotor is given below.

The multiturn data is sent according to the transmission specifications.

The position of the absolute encoder within one rotation is output as a pulse train.

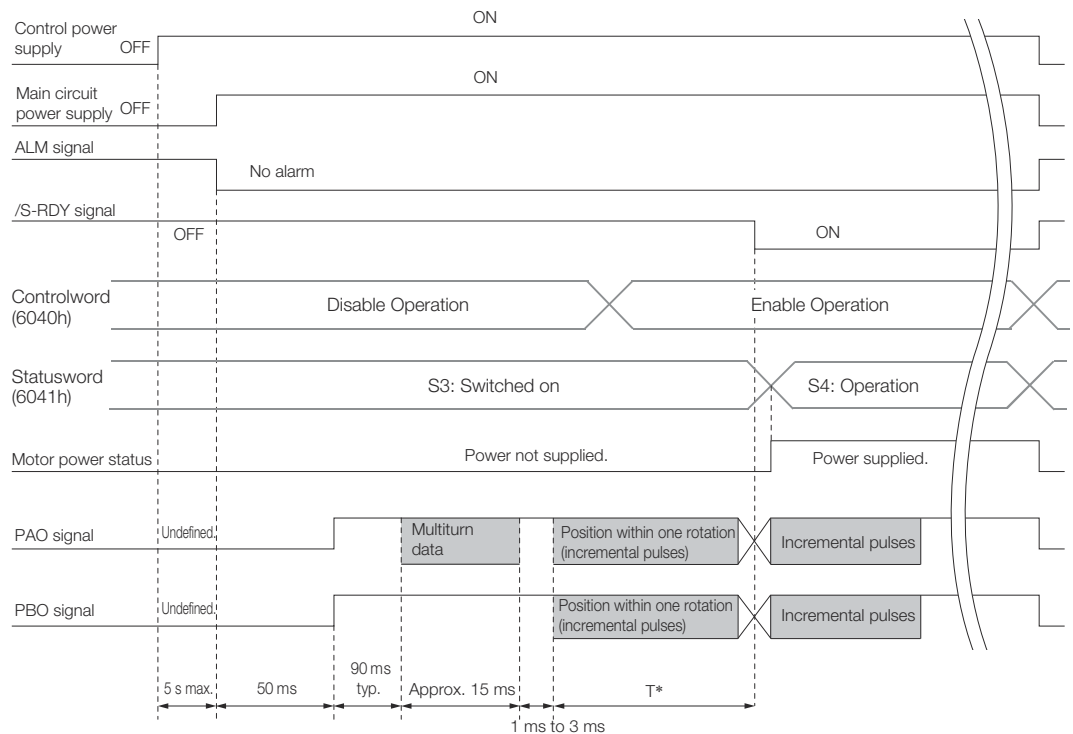


Fig. 168: Sequence to read the position data from the absolute encoder

* The pulse output time T for the position of the absolute encoder within one rotation depends on the setting of Pn212 (Number of Encoder Output Pulses). Refer to the following table.

Setting of Pn212	Calculation of the Pulse Output Speed for the Position of the Absolute Encoder within One Rotation	Calculation of the Pulse Output Time T for the Position of the Absolute Encoder within One Rotation
16 to 16,384	$680 \times \text{Pn212}/16,384$ [kpps]	25 ms max.
16,386 to 32,768	$680 \times \text{Pn212}/32,768$ [kpps]	50 ms max.
32,722 to 65,536	$680 \times \text{Pn212}/65,536$ [kpps]	100 ms max.

Setting of Pn212	Calculation of the Pulse Output Speed for the Position of the Absolute Encoder within One Rotation	Calculation of the Pulse Output Time T for the Position of the Absolute Encoder within One Rotation
65,544 to 131,072	$680 \times \text{Pn212}/131,072$ [kpps]	200 ms max.
131,088 to 262,144	$680 \times \text{Pn212}/262,144$ [kpps]	400 ms max.
262,176 to 524,288	$680 \times \text{Pn212}/524,288$ [kpps]	800 ms max.
524,352 to 1,048,576	$680 \times \text{Pn212}/1,048,576$ [kpps]	1,600 ms max.
1,048,704 to 2,097,152	$680 \times \text{Pn212}/2,097,152$ [kpps]	3,200 ms max.
2,097,408 to 4,194,304	$680 \times \text{Pn212}/4,194,304$ [kpps]	6,400 ms max.

7.9.6 Transmission Specifications

The position data transmission specifications for the PAO (Encoder Divided Pulse Output) signal are given in the following table.

The PAO signal sends only the multiturn data.

Refer to the following section for the timing of sending the position data from the absolute encoder.

→ [Chap. 7.9.5 'Reading the Position Data from the Absolute Encoder' ...page 221](#)

Item	PAO signal
Synchronization Method	Start-stop synchronization (ASYNCR)
Baud Rate	9,600 bps
Start Bits	1 bit
Stop Bits	1 bit
Parity	Even
Character Code	ASCII, 7 bits
Data Format	Refer to Data Format of PAO Signal.
Data Output Period	Only once after the control power supply is turned ON

Data Format of PAO Signal

As shown below, the message format consists of eight characters: "P," the sign, the 5-digit multiturn data, and "CR" (which indicates the end of the message).

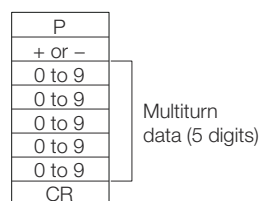


Fig. 169: Message Format of PAO Signal

7.9.7 Calculating the Current Position in Machine Coordinates

When you reset the absolute encoder, the reset position becomes the reference position.

The host controller reads the coordinate P_S from the origin of the encoder coordinate system. The host controller must record the value of coordinate P_S .

This section describes the reference position in the machine coordinate system.

The method to calculate the coordinate value of the present position from the origin of the machine coordinate system is given below.

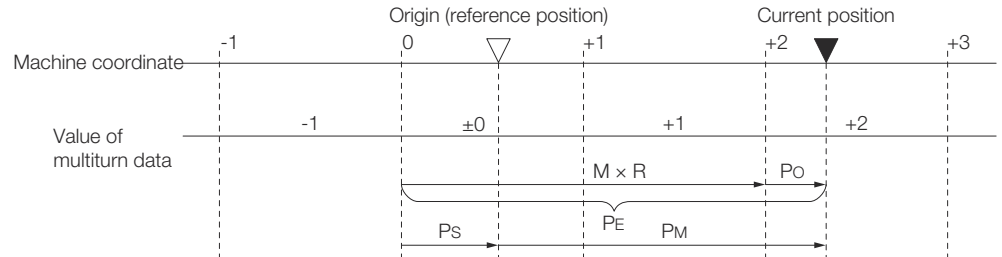


Fig. 170: Calculating the Coordinate Value of the Present Position from the Origin of the Machine

The current position P_M in the machine coordinate system is calculated as follows:

$$P_M = P_E - P_S$$

$$P_E = M \times R + P_O$$

$$P_S = M_S \times R + P_S'$$

Symbol	Meaning
P_E	Position data for the current position of the absolute encoder
M	Current position of the multiturn data of the absolute encoder
P_O	Position of the current position within one rotation
P_S	Position data of the absolute encoder when absolute encoder was reset
M_S	Multiturn data of the absolute encoder when absolute encoder was reset
P_S'	Position of the absolute encoder within one rotation when absolute encoder was reset
P_M	Current position in machine coordinate system
R	Pulses output per encoder rotation (value after dividing; setting of Pn212)



The following formulas apply in Reverse Rotation Mode ($Pn000 = n.\square\square\square 1$).

$$P_M = P_E - P_S$$

$$P_E = -M \times R + P_O$$

$$P_S = M_S \times R + P_S'$$



- If you are using a Rotary Servomotor, you must reset the absolute encoder. Refer to the following section for information on resetting the absolute encoder.
 ➔ Chap. 6.16.1 'Resetting the Absolute Encoder' ...page 179
- You can set the origin to a different position from the reset position. Refer to the following section for information on the origin position offset.
 ➔ Chap. 6.17.1 'Setting the Origin of the Absolute Encoder' ...page 183

7.9.8 Multiturn Limit Setting

The multiturn limit is used in position control for a turntable or other rotating body.

For example, consider a machine that moves the turntable shown in the following diagram in only one direction.

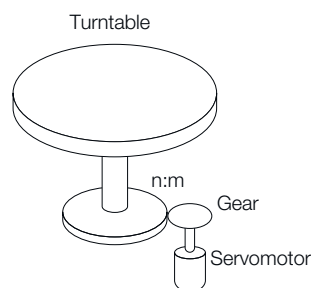


Fig. 171: Turntable Application Example

Because the turntable moves in only one direction, the upper limit to the number of rotations that can be counted by an absolute encoder will eventually be exceeded.

The multiturn limit is used in cases like this to prevent fractions from being produced by the integral ratio of the number of Servomotor rotations and the number of turntable rotations.

For a machine with a ratio of n:m between the number of Servomotor rotations and the number of turntable rotations, as shown above, the value of m minus 1 will be the setting for the multiturn limit setting (Pn205).

Multiturn limit (Pn205) = m - 1

If m = 100 and n = 3 (i.e., the turntable rotates three times for each 100 Servomotor rotations), the relationship between the number of Servomotor rotations and the number of turntable rotations would be as shown below.

Set Pn205 to 99.

$Pn205 = 100 - 1 = 99$

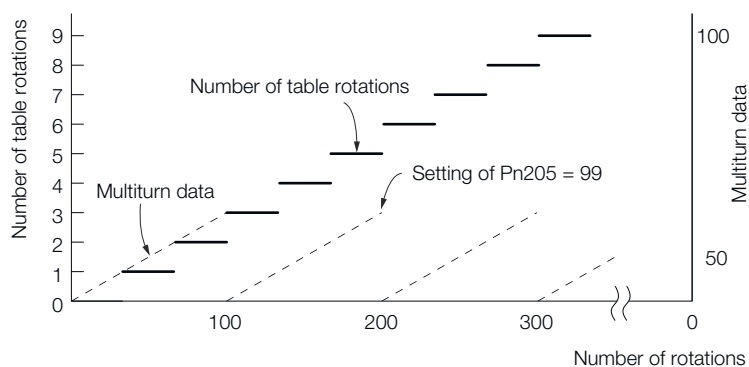


Fig. 172: Relationship Between the Number of Turntable Revolutions and the Number of Motor Revolutions

Multiturn Limit

	Setting Range	Setting Unit	Default Setting	When Enabled	Classification
Pn205	0 to 65,535	1 Rev	65,535	After restart	Setup

(applies to Speed Control, Position Control and Torque Control)



This parameter is enabled when you use an absolute encoder.

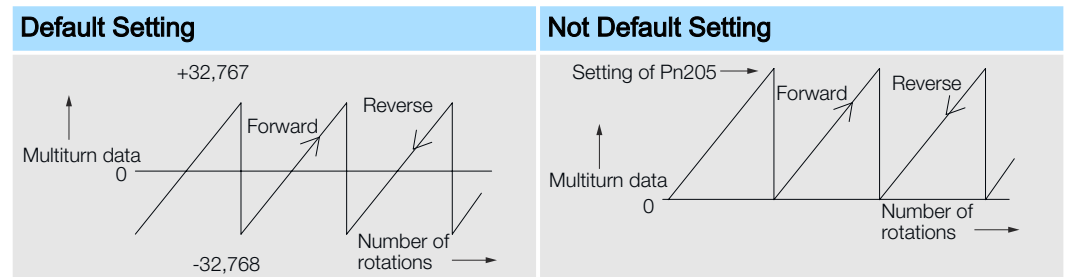
The data will change as shown below when this parameter is set to anything other than the default setting.

- If the Servomotor operates in the reverse direction when the multiturn data is 0, the multiturn data will change to the value set in Pn205.
- If the motor operates in the forward direction when the multiturn data is at the value set in Pn205, the multiturn data will change to 0.

Set Pn205 to one less than the desired multiturn data.

If you change the multiturn limit in Pn205, an A.CC0 alarm (Multiturn Limit Disagreement) will be displayed because the setting disagrees with the value in the encoder. Refer to the following section for the procedure to change the multiturn limit settings in the encoder.

→ [Chap. 7.9.9 'Multiturn Limit Disagreement Alarm \(A.CC0\)' ...page 225](#)



The multiturn data will always be 0 in the following cases. It is not necessary to reset the absolute encoder in these cases.

- When you use a single-turn absolute encoder
When the encoder is set to be used as a single-turn absolute encoder (Pn002 = n. □2□□)

Absolute encoder-related alarms (A.810 and A.820) will not occur.

7.9.9 Multiturn Limit Disagreement Alarm (A.CC0)


If you change the multiturn limit in Pn205 (Multiturn Limit), an A.CC0 alarm (Multiturn Limit Disagreement) will be displayed because the setting disagrees with the value in the encoder.

Display	Name	Meaning
A.CC0	Multiturn Limit Disagreement	Different multiturn limits are set in the encoder and SERVOPACK.

If this alarm is displayed, use the following procedure to change the multiturn limit in the encoder to the same value as the setting of Pn205.





Applicable Tools

The following table lists the tools that you can use to set the multiturn limit.

Tool	Function	Operating Procedure Reference
Digital Operator	Fn013	 Σ -7-Series Digital Operator Operating Manual (Manual No.: SIEP S800001 33)
SigmaWin+	Setup - Multiturn Limit Setting	↪ 'Operating Procedure' ...page 226

Operating Procedure

Use the following procedure to adjust the multiturn limit setting.

1.  Click the  Servo Drive Button in the workspace of the Main Window of the SigmaWin+.
2.  Select **Multiturn Limit Setting** in the Menu Dialog Box.
 - ➔ The Multiturn Limit Setting Dialog Box will be displayed.
3.  Click the **Continue** Button.

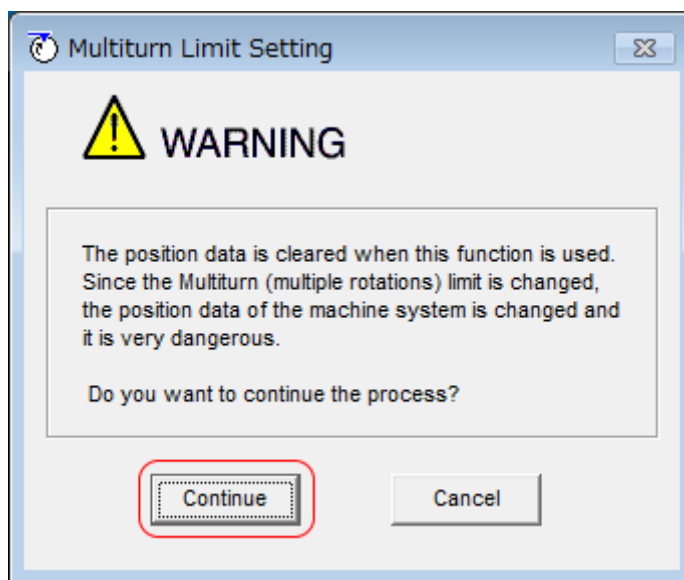


Fig. 173: Multiturn Limit Setting - Warning

- ➔ Click the **Cancel** Button to cancel setting the multiturn limit. The Main Window will return.

4. → Change the setting.

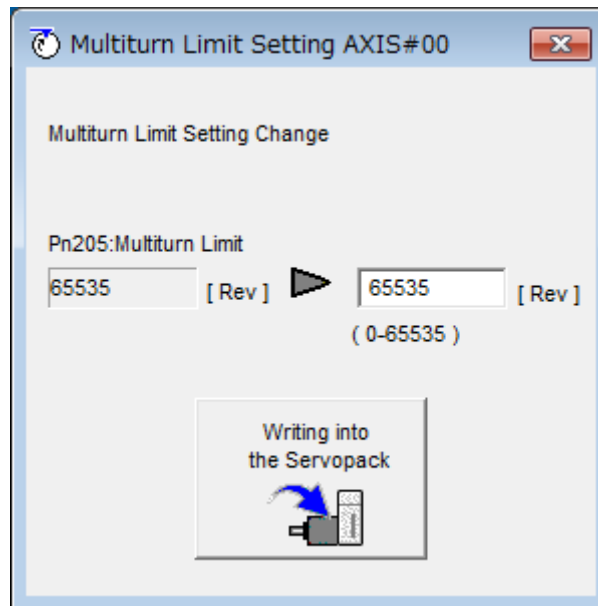


Fig. 174: Multiturn Limit Setting Change

5. → Click the **Writing into the Servopack** Button.

6. → Click the **OK** Button.

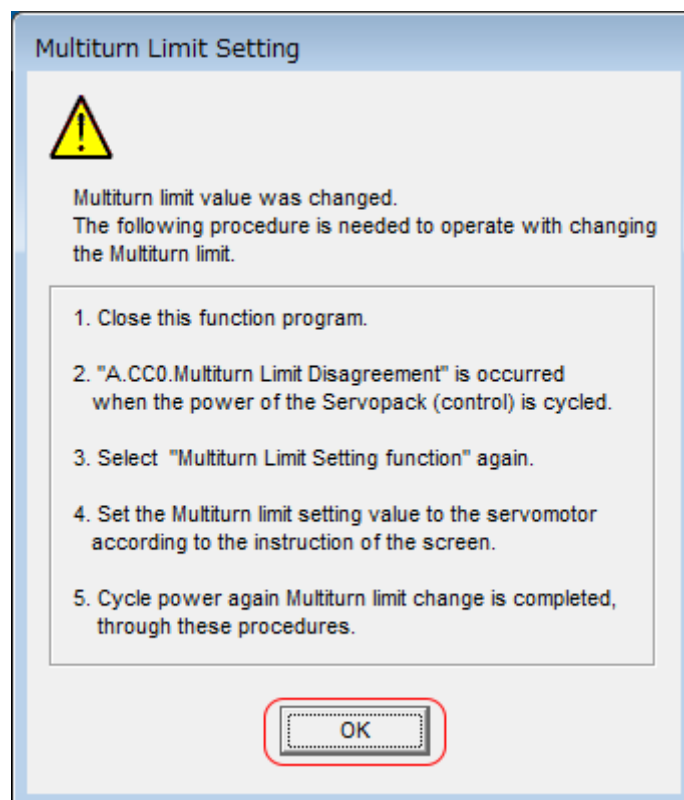


Fig. 175: Multiturn Limit Setting - Confirmation of Change Procedure

7. → Turn the power supply to the SERVOPACK OFF and ON again.

An A.CC0 alarm (Multiturn Limit Disagreement) will occur because setting the multi-turn limit in the Servomotor is not yet completed even though the setting has been changed in the SERVOPACK.

Absolute Encoders > Multiturn Limit Disagreement Alarm (A.CC0)

8. → Display the Multiturn Limit Setting in the Menu Dialog Box.

9. → Click the **Continue** Button.

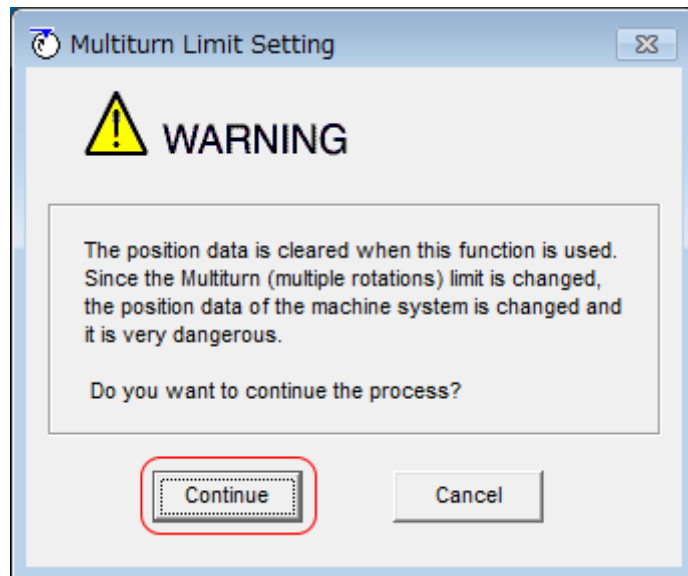


Fig. 176: Multiturn Limit Setting - Warning

10. → Click the **Writing into the Motor** Button.

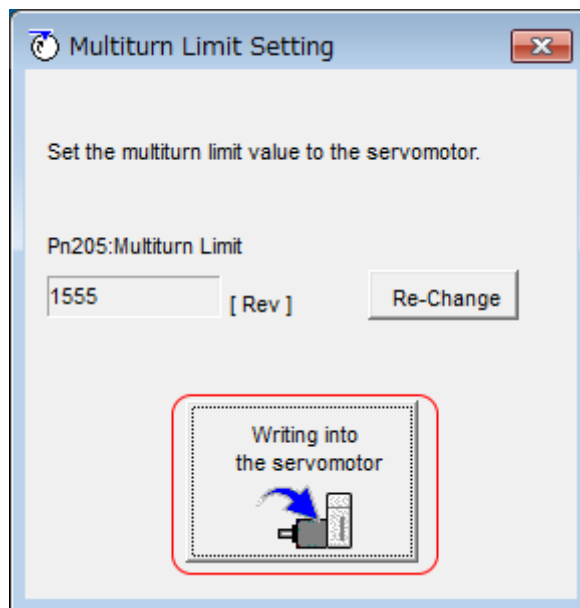


Fig. 177: Multiturn Limit Setting - Writing into the Servomotor

➔ Click the **Re-change** Button to change the setting.

11. Click the OK Button.

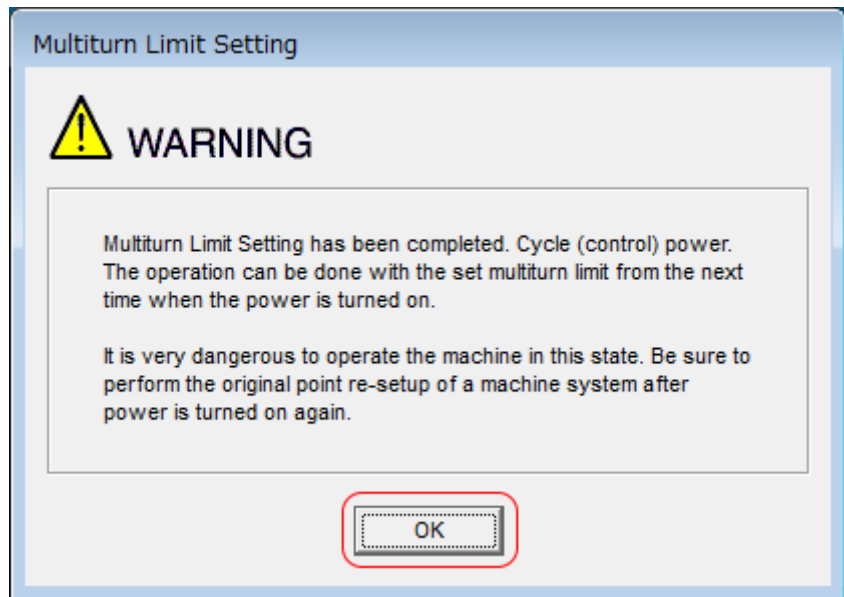


Fig. 178: Multiturn Limit Setting - Cycle Control Power Warning

This concludes the procedure to set the multiturn limit.

7.10 Absolute Linear Encoders

7.10.1 Overview

The absolute linear encoder records the current position of the stop position even when the power supply is OFF.

With a system that uses an absolute linear encoder, the host controller can monitor the current position. Therefore, it is not necessary to perform an origin return operation when the power supply to the system is turned ON.

There are two types of linear encoders for Linear Servomotors. The usage of the linear encoder is specified in Pn002 = n.□X□□.

Refer to the following section for linear encoder models.

↪ [‘Calculating the Settings for the Electronic Gear Ratio’ ...page 173](#)

Parameter Settings When Using an Incremental Linear Encoder

Parameter	Meaning	When Enabled	Classification
Pn002	n.□0□□ (default setting)	After restart	Setup
	n.□1□□		

Parameter Settings When Using an Absolute Linear Encoder

Parameter	Meaning	When Enabled	Classification
Pn002	n.□0□□ (default setting)	After restart	Setup

Parameter	Meaning	When Enabled	Classification
n.□1□□	Use the encoder as an incremental linear encoder.		

7.10.2 Connecting an Absolute Linear Encoder

You can get the position data from the absolute linear encoder with PROFINET communications. Therefore, it is not necessary to wire the PAO, PBO, and PCO (Encoder Divided Pulse Output) signals.

If they need to be wired, refer to the following section.

→ Chap. 5.5.3.1 'Wiring the SERVOPACK to the Encoder' ...page 106

→ Chap. 5.6.3 'I/O Signal Wiring Examples' ...page 117

7.10.3 Structure of the Position Data of the Absolute Linear Encoder

The position data of the absolute linear encoder is the distance (number of pulses) from the origin of the absolute linear encoder.

The position data is signed 36-bit data.

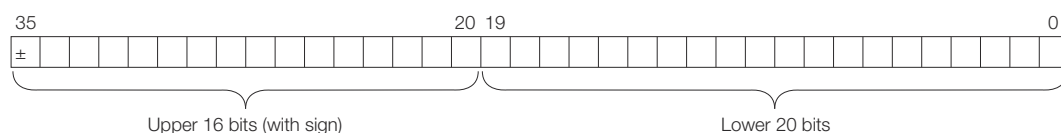


Fig. 179: Structure of the Position Data of the Absolute Linear Encoder

When the SERVOPACK sends the position data, it sends the upper 16-bit data (with sign) separately from the lower 20-bit data.

7.10.4 Output Ports for the Position Data from the Absolute Linear Encoder

You can read the position data of the absolute linear encoder from the PAO, PBO, and PCO (Encoder Divided Pulse Output) signals.

The output method and timing for the position data of the absolute linear encoder are different in each case.

A conceptual diagram of the connections of the PAO, PBO, and PCO (Encoder Divided Pulse Output) ports to the host controller is provided below.

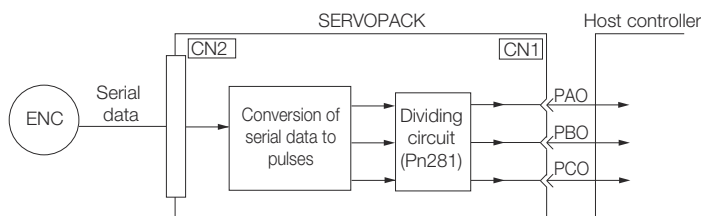


Fig. 180: Output Ports for the Position Data from the Absolute Linear Encoder

Signal	Status	Signal Contents
		When Using an Absolute Linear Encoder
PAO	First signal	Upper 16-bit data (with sign) Lower 20-bit data (pulse train)
	During normal operation	Incremental pulses
PBO	First signal	Lower 20-bit data (pulse train)

Signal	Status	Signal Contents
		When Using an Absolute Linear Encoder
	During normal operation	Incremental pulses
PCO	Always	Origin pulse

The PAO (Encoder Divided Pulse Output) signal outputs the position data from the absolute linear encoder after the control power supply is turned ON.

The position data of the absolute linear encoder is the current stop position. The absolute linear encoder outputs the upper 16-bit data (with sign) according to the specified protocol. The absolute encoder outputs the lower 20-bit data as a pulse train. It then outputs pulses as an incremental linear encoder (incremental operation status).

The host controller must have a reception circuit (e.g., UART) for the position data from the absolute linear encoder. The pulse counter at the host controller will not count pulses when the upper 16-bit data (with sign) (communications message) is input because only phase A is input.

The output circuits for the PAO, PBO, and PCO signals use line drivers. Refer to the following section for details on line drivers.

→ Chap. 5.6.4 'I/O Circuits' ...page 119

7.10.5 Reading the Position Data from the Absolute Linear Encoder

The sequence to read the position data from the absolute linear encoder of a Linear Servomotor is given below.

The upper 16-bit position data (with sign) are sent according to the transmission specifications.

The lower 20-bit data is output as a pulse train.

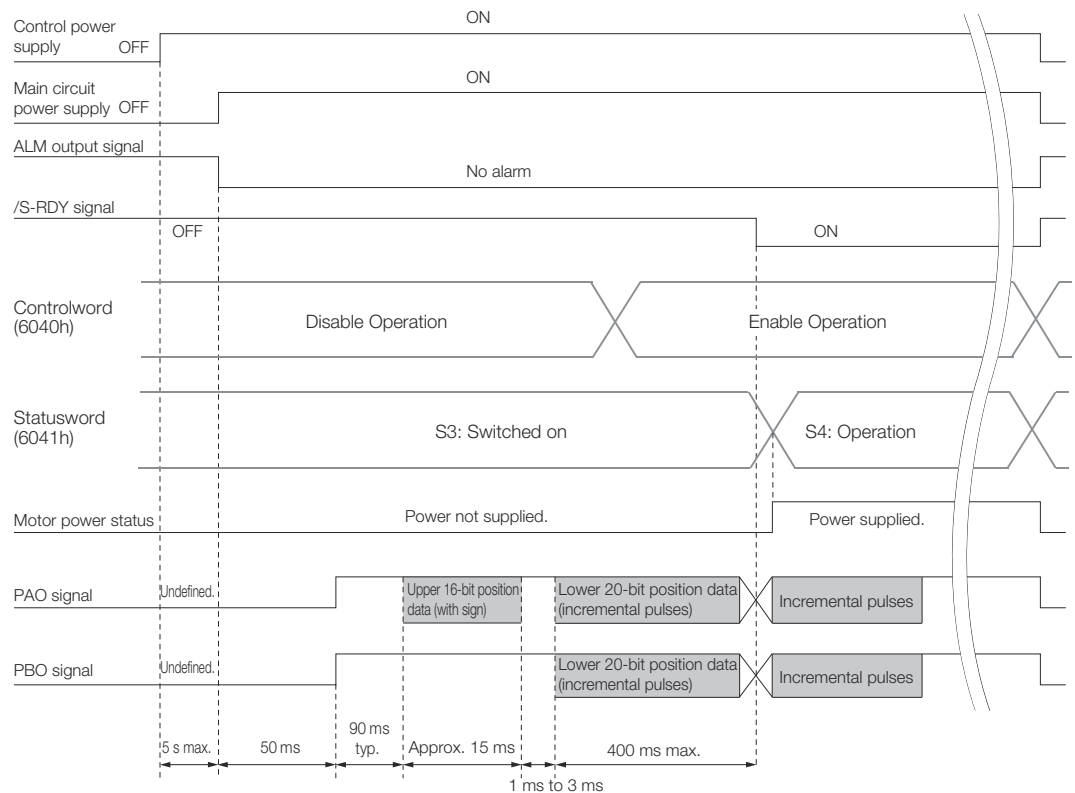


Fig. 181: Reading the Position Data from the Absolute Linear Encoder

7.10.6 Transmission Specifications

The position data transmission specifications for the PAO (Encoder Divided Pulse Output) signal are given in the following table.

The PAO signal sends only the 16-bit data (with sign).

Refer to the following section for the timing of sending the position data from the absolute encoder.

→ [Chap. 7.10.5 'Reading the Position Data from the Absolute Linear Encoder' ...page 231](#)

Item	PAO signal
Synchronization Method	Start-stop synchronization (ASYNCR)
Baud Rate	9,600 bps
Start Bits	1 bit
Stop Bits	1 bit
Parity	Even
Character Code	ASCII, 7 bits
Data Format	Refer to <i>Data Format of PAO Signal</i> .
Data Output Period	Only once after the control power supply is turned ON

Data Format of PAO Signal

As shown below, the message format consists of eight characters: "P," the sign, the 5-digit upper 15-bit position data, and "CR" (which indicates the end of the message).

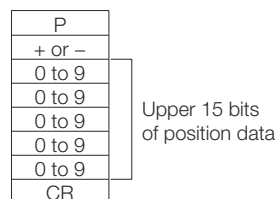


Fig. 182: Data Format of PAO Signal

7.10.7 Calculating the Current Position in Machine Coordinates

With an absolute linear encoder, you must set the position of the origin (i.e., the origin of the machine coordinate system).

The host controller reads the coordinate from the origin of the encoder coordinate system. The host controller must record the value of this coordinate.

The method to calculate the coordinate value of the present position from the origin of the machine coordinate system is given below.

The position data from the absolute linear encoder is signed 36-bit data, but the upper 16 bits (with sign) and the lower 20 bits are output separately.

For the upper 16-bit data (with sign), the upper bits (16 bits, including the sign) of the current position after dividing by the setting of Pn281 are output with serial communications according to the transmission specifications.

For the lower 20-bit data, the lower bits (20 bits) of the current position after dividing by the setting of Pn281 are output as a pulse train.

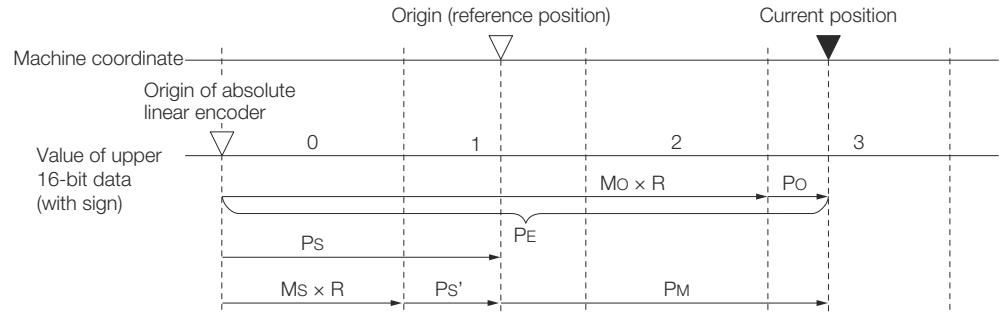


Fig. 183: Calculating the Current Position in Machine Coordinates

The current position P_M in the machine coordinate system is calculated as follows:

$$P_M = P_E - P_S$$

$$P_E = M_O \times R + P_O$$

$$P_S = M_S \times R + P_S'$$

Symbol	Meaning
P_E	Position data for the current position of the absolute linear encoder
M_O	Upper 16 bits (with sign) of the position data for the current position of the absolute linear encoder
P_O	Lower 20 bits of the position data for the current position of the absolute linear encoder
P_S	Position data of the origin
M_S	Upper 16 bits (with sign) of the position data of the origin
P_S'	Lower 20 bits of the position data of the origin
P_M	Current position in machine coordinate system
R	1048576 ($=2^{20}$)



The above formulas also apply in reverse movement mode ($Pn000 = n.\square\square\square1$).



If you are using a Linear Servomotor, you do not need to reset the absolute linear encoder to define the origin. (Some absolute linear encoders also allow you to set any position as the origin.)

7.11 Software Reset

7.11.1 Overview

You can reset the SERVOPACK internally with the software. A software reset is used when resetting alarms and changing the settings of parameters that normally require turning the power supply to the SERVOPACK OFF and ON again. This can be used to change those parameters without turning the power supply to the SERVOPACK OFF and ON again.



- Always confirm that the servo is OFF and that the Servomotor is stopped before you start a software reset (the servo cannot be reset when it is ON).
- This function resets the SERVOPACK independently of the host controller. The SERVOPACK carries out the same processing as when the power supply is turned ON and outputs the ALM (Servo Alarm) signal. The status of other output signals may be forcibly changed.
- When you execute a software reset, the SERVOPACK will not respond for approximately five seconds.
Before you execute a software reset, check the status of the SERVOPACK and Servomotor and make sure that no problems will occur.

7.11.2 Preparations

Confirm that the following conditions are met before you perform a software reset.

- The servo must be OFF.
- The motor must be stopped.

7.11.3 Applicable Tools

The following table lists the tools that you can use to perform a software reset.

Tool	Function	Operating Procedure Reference
Digital Operator	Fn030	Σ -7-Series Digital Operator Operating Manual (Manual No.: SIEP S800001 33)
SigmaWin+	Setup - Software Reset	↪ Chap. 7.11.4 'Operating Procedure' ...page 234

7.11.4 Operating Procedure

Use the following procedure to perform a software reset.

1. Click the Servo Drive Button in the workspace of the Main Window of the SigmaWin+.
2. Select **Software Reset** in the Menu Dialog Box.
 - ➔ The Software Reset Dialog Box will be displayed.

3. → Click the **Execute** Button.

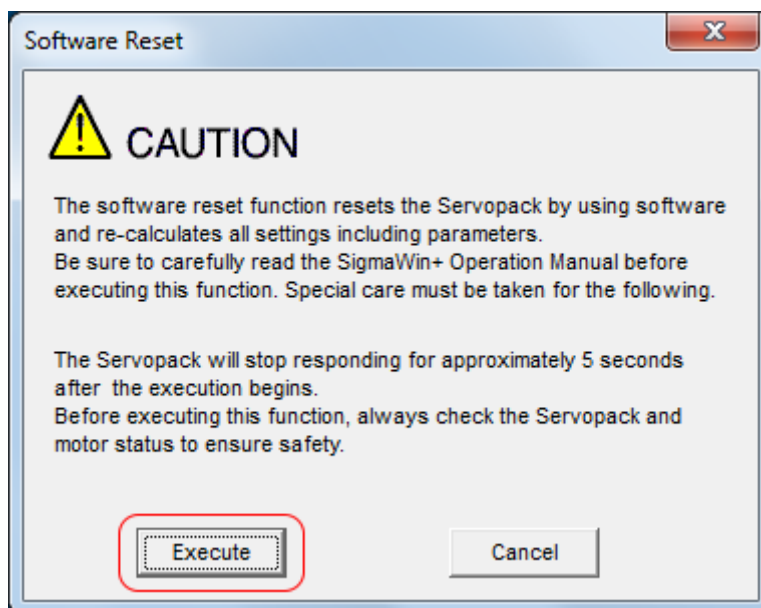


Fig. 184: Software Reset - Caution

4. → Click the **Execute** Button.

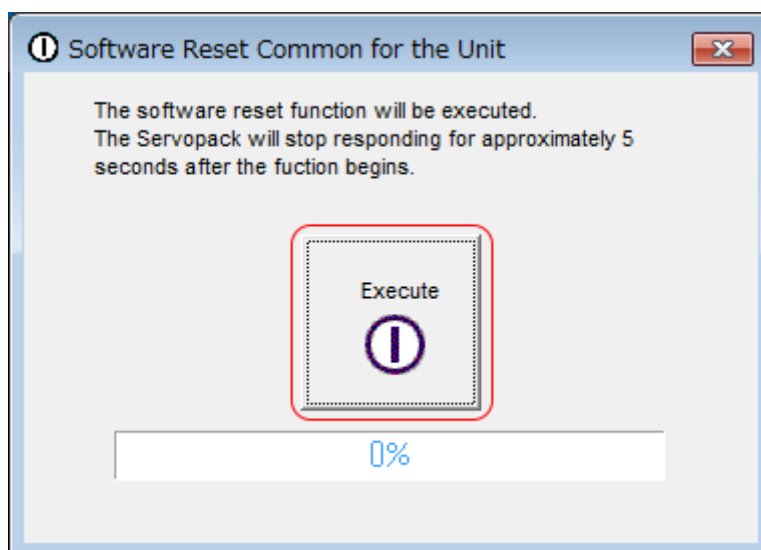


Fig. 185: Software Reset Common for the Unit

5. Click the **OK** Button to end the software reset operation.

All settings including parameters will have been re-calculated. When you finish this operation, disconnect the SigmaWin+ from the SERVOPACK, and then connect it again.

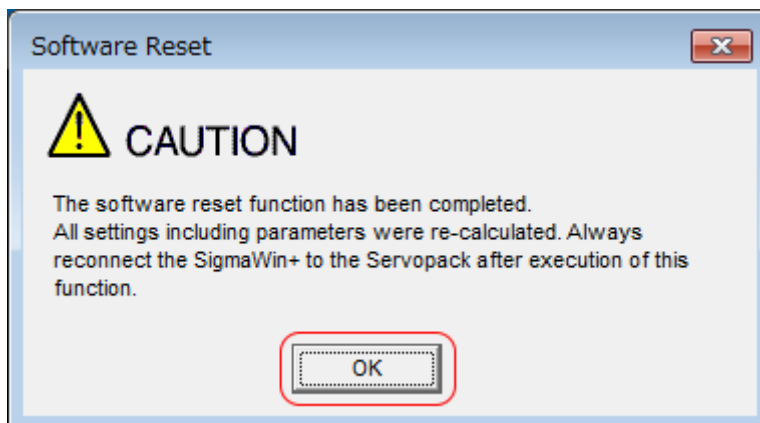


Fig. 186: Software Reset - Caution - All settings including parameters were re-calculated. This concludes the procedure to reset the software.

7.12 Initializing the Vibration Detection Level

7.12.1 Overview

You can detect machine vibration during operation to automatically adjust the settings of Pn312 or Pn384 (Vibration Detection Level) to detect A.520 alarms (Vibration Alarm) and A.911 warnings (Vibration Warning) more precisely.

This function detects specific vibration components in the Servomotor speed.

Parameter	Meaning	When Enabled	Classification
Pn310	n.□□□0 (default setting)		
	n.□□□1 Output a warning (A.911) if vibration is detected.	Immediately	Setup
	n.□□□2 Output an alarm (A.520) if vibration is detected.		

If the vibration exceeds the detection level calculated with the following formula, an alarm or warning occurs according to Pn310 (Vibration Detection Selection).

- Rotary Servomotors

$$\text{Detection level} = \frac{\text{Vibration detection level (Pn312 [min-1])} \times \text{Vibration detection sensitivity (Pn311 [\%])}{100}$$

Fig. 187: Calculation of Detection Level - Rotary Servomotors

- Linear Servomotors

$$\text{Detection level} = \frac{\text{Vibration detection level (Pn384 [mm/s])} \times \text{Vibration detection sensitivity (Pn311 [\%])}{100}$$

Fig. 188: Calculation of Detection Level - Linear Servomotors

Use this function only if A.520 or A.911 alarms are not output at the correct times when vibration is detected with the default vibration detection level (Pn312 or Pn384).

There will be discrepancies in the detection sensitivity for vibration alarms and warnings depending on the condition of your machine. If there is a discrepancy, use the above formula to adjust Pn311 (Vibration Detection Sensitivity).

Vibration Detection Sensitivity

	Setting Range	Setting Unit	Default Setting	When Enabled	Classification
Pn311	50 to 500	1%	100	Immediately	Tuning

(applies to Speed Control, Position Control and Torque Control)



- *Vibration may not be detected because of unsuitable servo gains. Also, not all kinds of vibrations can be detected.*
- *Set a suitable moment of inertia ratio (Pn103). An unsuitable setting may result in falsely detecting or not detecting vibration alarms or vibration warnings.*
- *To use this function, you must input the actual references that will be used to operate your system.*
- *Execute this function under the operating conditions for which you want to set the vibration detection level.*
- *Execute this function while the Servomotor is operating at 10% of its maximum speed or faster.*

7.12.2 Preparations

Check the following settings before you initialize the vibration detection level.

- The parameters must not be write prohibited.
- The test without a motor function must be disabled (Pn00C = n.□□□0).

7.12.3 Applicable Tools

The following table lists the tools that you can use to initialize the vibration detection level and the applicable tool functions.

Tool	Function	Operating Procedure Reference
Digital Operator	Fn01B	Σ -7-Series Digital Operator Operating Manual (Manual No.: SIEP S800001 33)
SigmaWin+	Setup - Initialize Vibration Detection Level	↪ Chap. 7.12.4 'Operating Procedure' ...page 237

7.12.4 Operating Procedure

Use the following procedure to initialize the vibration detection level.

1. Click the Servo Drive Button in the workspace of the Main Window of the SigmaWin+.
2. Select **Initialize Vibration Detection Level** in the Menu Dialog Box.
 - ➔ The Initialize Vibration Detection Level Dialog Box will be displayed.

3. → Select **Pn311: Vibration Detection Sensitivity** and **Pn310: Vibration Detection Selections** and then click the **Detection Start** Button.

A setting execution standby mode will be entered.

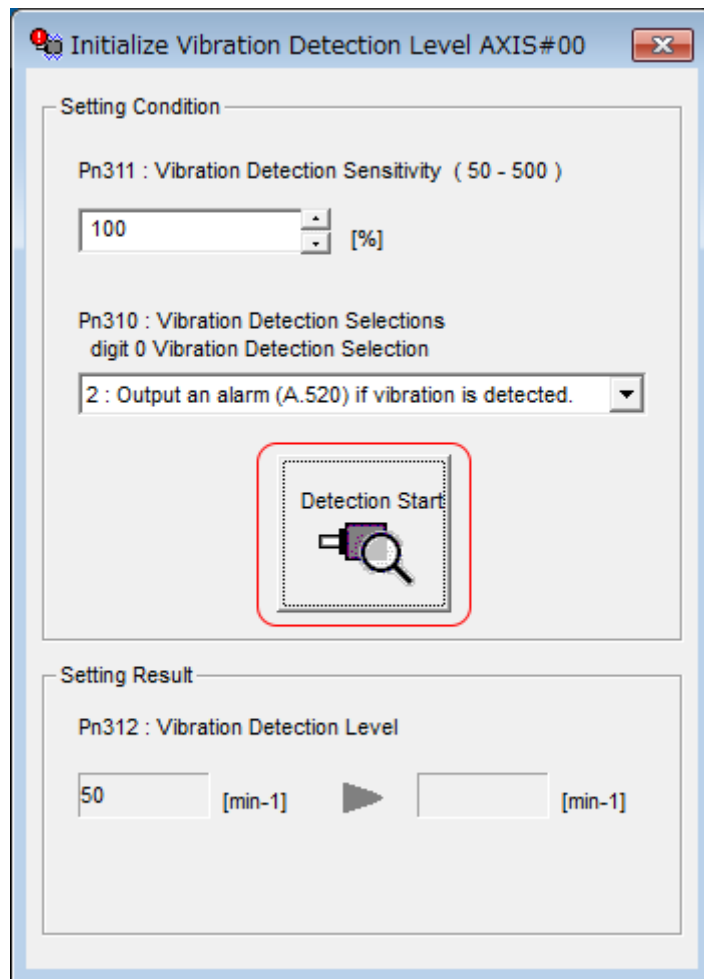


Fig. 189: Initialize Vibration Detection Level AXIS#00 - Detection Start

4. → Click the **Execute** Button.

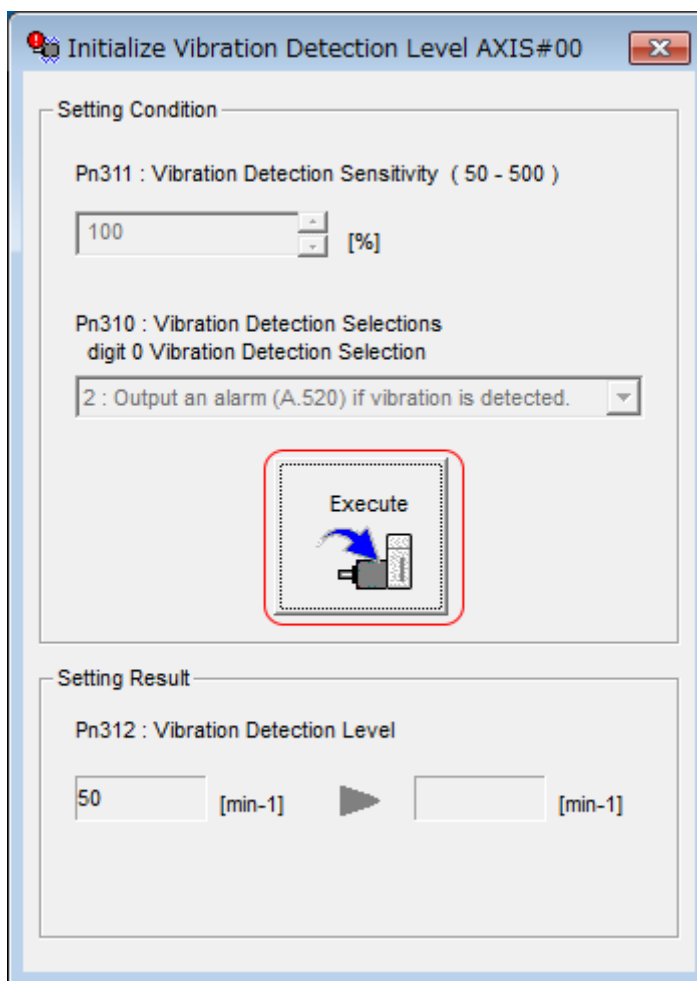


Fig. 190: Initialize Vibration Detection Level AXIS#00 - Execute

- ➔ The newly set vibration detection level will be displayed and the value will be saved in the SERVOPACK.

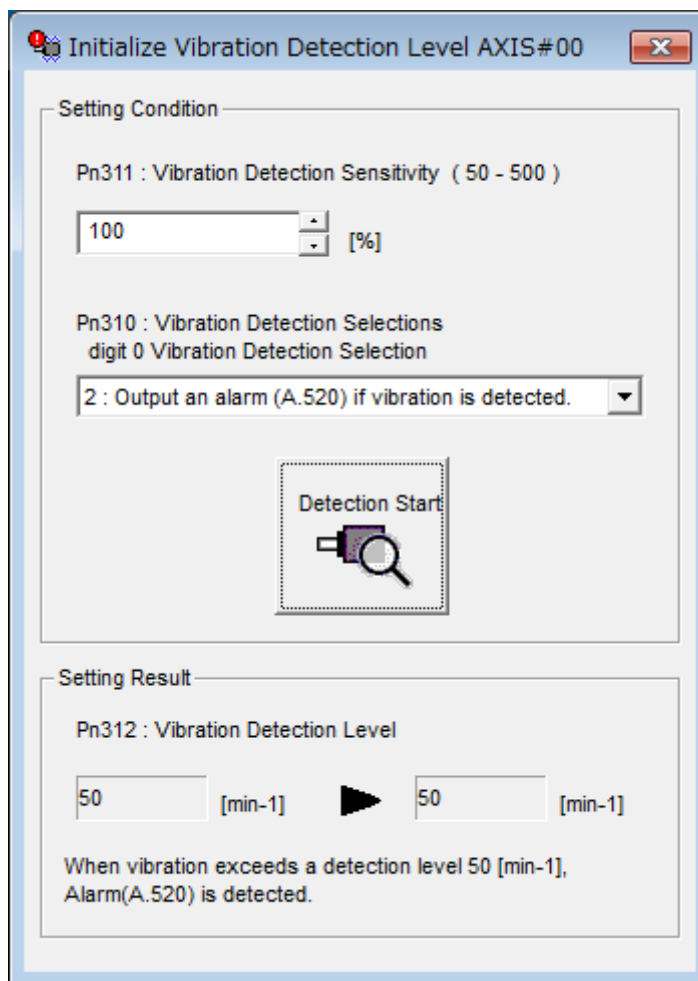


Fig. 191: Initialize Vibration Detection Level AXIS#00 - Setting Result

This concludes the procedure to initialize the vibration detection level.

7.12.5 Related Parameters

The following three items are given in the following table.

- Parameters Related to this Function
These are the parameters that are used or referenced when this function is executed.
- Changes during Function Execution
Not allowed: The parameter cannot be changed using the SigmaWin+ or other tool while this function is being executed.
Allowed: The parameter can be changed using the SigmaWin+ or other tool while this function is being executed.
- Automatic Changes after Function Execution
Yes: The parameter is automatically set or adjusted after execution of this function.
No: The parameter is not automatically set or adjusted after execution of this function.

Parameter	Name	Setting Changes	Automatic Changes
Pn311	Vibration Detection Sensitivity	Allowed	No
Pn312	Vibration Detection Level	Not allowed	Yes
Pn384	Vibration Detection Level	Not allowed	Yes

7.13 Adjusting the Motor Current Detection Signal Offset

7.13.1 Overview

The motor current detection signal offset is used to reduce ripple in the torque. You can adjust the motor current detection signal offset either automatically or manually.

7.13.2 Automatic Adjustment

Perform this adjustment only if highly accurate adjustment is required to reduce torque ripple. It is normally not necessary to adjust this offset.



Execute the automatic offset adjustment if the torque ripple is too large when compared with other SERVOPACKs.



The offset does not use a parameter, so it will not change even if the parameter settings are initialized.

Preparations

Always check the following before you automatically adjust the motor current detection signal offset.

- The parameters must not be write prohibited.
- The servo must be in ready status.
- The servo must be OFF.

Applicable Tools

The following table lists the tools that you can use to automatically adjust the offset.

Tool	Function	Operating Procedure Reference
Digital Operator	Fn00E	Σ -7-Series Digital Operator Operating Manual (document No. SIEP S800001 33)
SigmaWin+	Setup - Adjust Offset - Adjust the Motor Current Detection Offset	↪ 'Operating Procedure' ...page 241

Operating Procedure

Use the following procedure to automatically adjust the motor current detection signal offset.

1. Click the Servo Drive Button in the workspace of the Main Window of the SigmaWin+.
2. Select **Adjust the Motor Current Detection Signal Offsets** in the Menu Dialog Box.
 - ➔ The Adjust the Motor Current Detection Signal Offsets Dialog Box will be displayed.

Adjusting the Motor Current Detection Signal Offset > Automatic Adjustment

3. → Click the **Continue** Button.

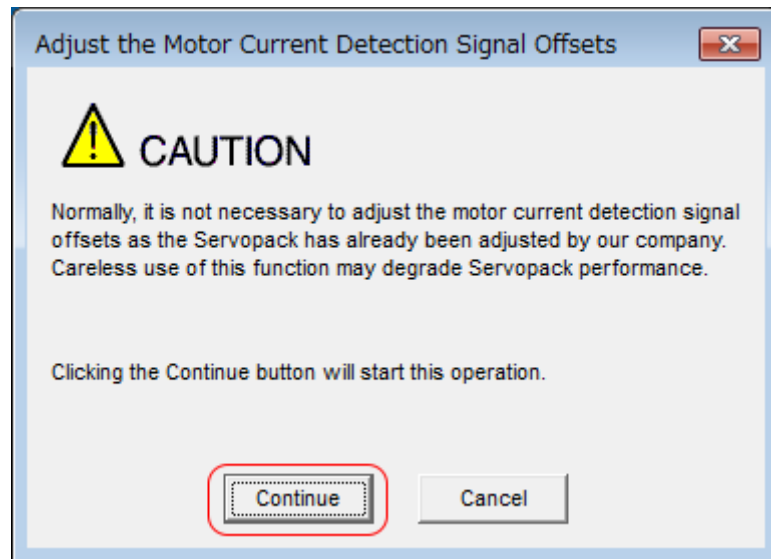


Fig. 192: Adjust the Motor Current Detection Signal Offsets - Caution

4. → Click the **Automatic Adjustment** Tab in the Adjust the Motor Current Detection Signal Offsets Dialog Box.

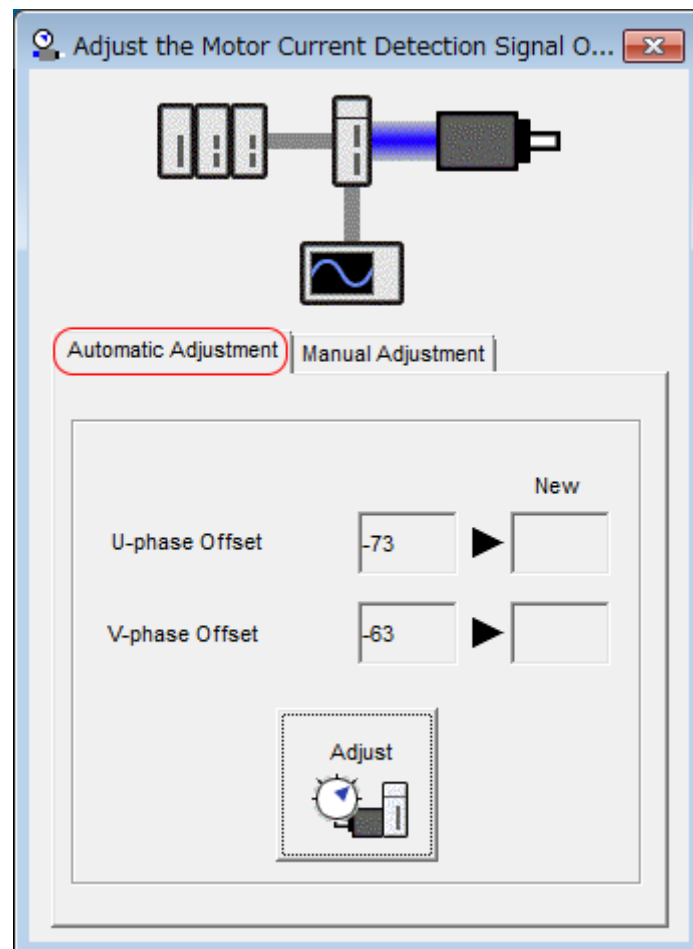


Fig. 193: Adjust the Motor Current Detection Signal Offsets - Automatic Adjustment

5. → Click the **Adjust** Button.
- The values that result from automatic adjustment will be displayed in the **New** Boxes.

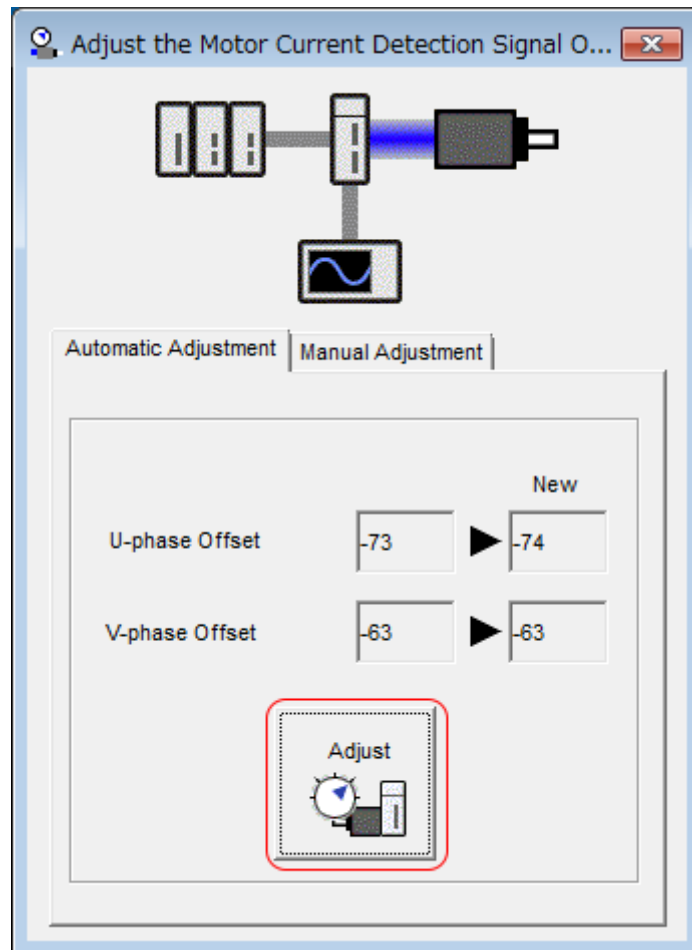


Fig. 194: Adjust the Motor Current Detection Signal Offsets - Adjust

This concludes the procedure to automatically adjust the motor current detection signal offset.

7.13.3 Manual Adjustment

You can use this function if you automatically adjust the motor current detection signal offset and the torque ripple is still too large.



If the offset is incorrectly adjusted with this function, the Servomotor characteristics may be adversely affected.

Observe the following precautions when you manually adjust the offset.

- Operate the Servomotor at a speed of approximately 100 min^{-1} .
- Adjust the offset while monitoring the torque reference with the analog monitor until the ripple is minimized.
- Adjust the offsets for the phase-U current and phase-V current of the Servomotor so that they are balanced. Alternately adjust both offsets several times.



The offset does not use a parameter, so it will not change even if the parameter settings are initialized.

Preparations

Always check the following before you manually adjust the motor current detection signal offset.

- The parameters must not be write prohibited.

Applicable Tools

The following table lists the tools that you can use to manually adjust the offset and the applicable tool functions.

Tool	Function	Operating Procedure Reference
Digital Operator	Fn00F	Σ -7-Series Digital Operator Operating Manual (document No. SIEP S800001 33)
SigmaWin+	Setup - Adjust Offset - Adjust the Motor Current Detection Offset	↪ 'Operating Procedure' ...page 244

Operating Procedure

Use the following procedure to manually adjust the motor current detection signal offset.

1. Operate the Servomotor at approximately 100 min⁻¹.
2. Click the Servo Drive Button in the workspace of the Main Window of the SigmaWin+.
3. Select **Adjust the Motor Current Detection Signal Offsets** in the Menu Dialog Box.
 - ➔ The Adjust the Motor Current Detection Signal Offsets Dialog Box will be displayed.
4. Click the **Continue** Button.
 - ➔

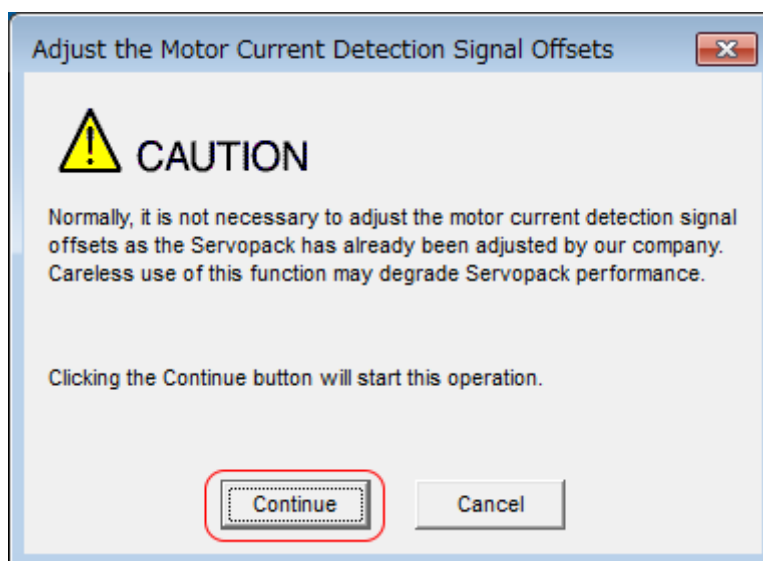


Fig. 195: Adjust the Motor Current Detection Signal Offsets - Caution

5. Click the **Manual Adjustment** Tab in the Adjust the Motor Current Detection Signal Offsets Dialog Box.

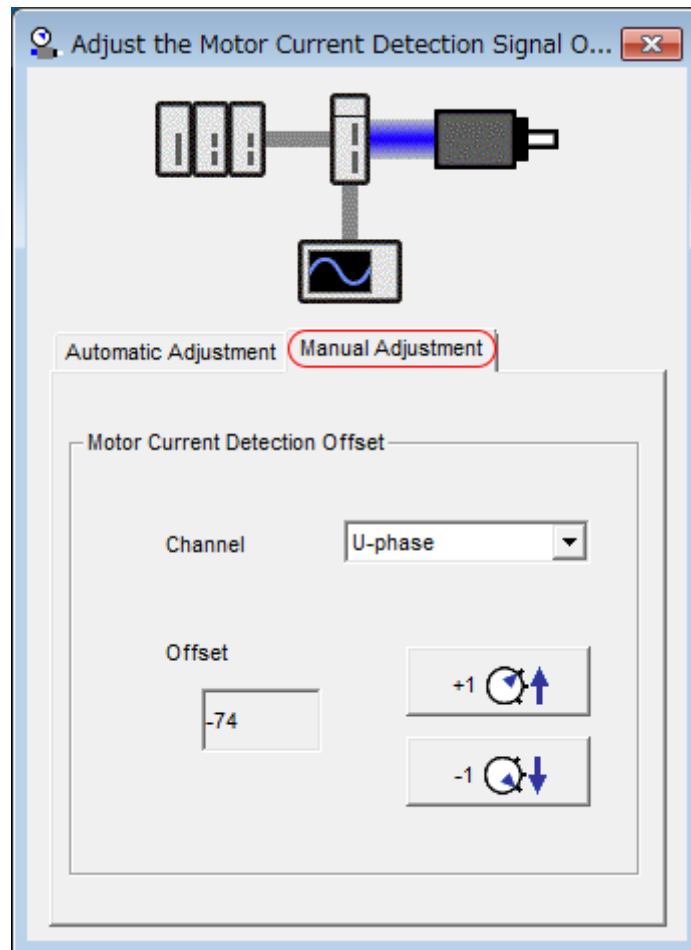


Fig. 196: Adjust the Motor Current Detection Signal Offsets - Manual Adjustment

6. Set the **Channel** Box in the **Motor Current Detection Offset** Area to **U-phase**.
7. Use the **+1** and **-1** Buttons to adjust the offset for phase U.
Change the offset by about 10 in the direction that reduces the torque ripple.
Adjustment range: -512 to +511
8. Set the **Channel** Box in the **Motor Current Detection Offset** Area to **V-phase**.
9. Use the **+1** and **-1** Buttons to adjust the offset for phase V.
Change the offset by about 10 in the direction that reduces the torque ripple.
10. Repeat steps 6 to 9 until the torque ripple cannot be decreased any further regardless of whether you increase or decrease the offsets.
11. Reduce the amount by which you change the offsets each time and repeat steps 6 to 9.

This concludes the procedure to manually adjust the motor current detection signal offset.

7.14 Forcing the Motor to Stop

7.14.1 Overview

You can force the Servomotor to stop for a signal from the host controller or an external device.

Forcing the Motor to Stop > Stopping Method Selection for Forced Stops

To force the motor to stop, you must allocate the FSTP (Forced Stop Input) signal in Pn516 = n.□□□X. You can specify one of the following stopping methods: dynamic brake (DB), coasting to a stop, or decelerating to a stop.



Forcing the motor to stop is not designed to comply with any safety standard. In this respect, it is different from the hard wire base block (HWBB).



Panel Display and Digital Operator Display

When a forced stop is performed, the panel and the Digital Operator will display FSTP.



CAUTION

To prevent accidents that may result from contact faults or disconnections, use a normally closed switch for the Forced Stop Input signal.

7.14.2 FSTP (Forced Stop Input) Signal

Classification	Signal	Connector Pin No.	Signal Status	Description
Input	FSTP	Must be allocated.	ON (closed)	Drive is enabled (normal operation).
			OFF (open)	The motor is stopped.



You must allocate the FSTP signal to use it. Use Pn516 = n.□□□X (FSTP (Forced Stop Input) Signal Allocation) to allocate the FSTP signal to a connector pin. Refer to the following section for details.

[↪ Chap. 7.2.2 'Input Signal Allocations' ...page 189](#)

7.14.3 Stopping Method Selection for Forced Stops

Use Pn00A = n.□□□□ (Stopping Method for Forced Stops) to set the stopping method for forced stops.

Parameter	Meaning	When Enabled	Classification
Pn00A	n.□□0□	After restart	Setup
	n.□□1□ (default setting)		
	Apply the dynamic brake or coast the motor to a stop (use the stopping method set in Pn001 = n.□□□X).		
	Decelerate the motor to a stop using the torque set in Pn406 as the maximum torque. Use the setting of Pn001 = n.□□□X for the status after stopping.		

Parameter	Meaning	When Enabled	Classification
n.□□2□	Decelerate the motor to a stop using the torque set in Pn406 as the maximum torque and then let the motor coast.		
n.□□3□	Decelerate the motor to a stop using the deceleration time set in Pn30A. Use the setting of Pn001 = n.□□□X for the status after stopping.		
n.□□4□	Decelerate the motor to a stop using the deceleration time set in Pn30A and then let the motor coast.		



You cannot decelerate a Servomotor to a stop during torque control. For torque control, the Servomotor will be stopped with the dynamic braking or coast to a stop according to the setting of Pn001 = n.□□□X (Motor Stopping Method for Servo OFF and Group 1 Alarms).

Stopping the Servomotor by Setting Emergency Stop Torque (Pn406)

To stop the Servomotor by setting emergency stop torque, set Pn406 (Emergency Stop Torque).

The PROFINET module sets Pn001 = n.□□1□ during power-up. The Servomotor will be decelerated to a stop using the torque set in Pn406 as the maximum torque and then servolock the motor.

The default setting is 800%. This setting is large enough to allow you to operate the Servomotor at the maximum torque. However, the maximum emergency stop torque that you can actually use is the maximum torque of the Servomotor.

Emergency Stop Torque

	Setting Range	Setting Unit	Default Setting	When Enabled	Classification
Pn406	0 to 800	1%*	800	Immediately	Setup

(applies to Speed Control and Position Control)

* Set a percentage of the motor rated torque.

Stopping the Servomotor by Setting the Deceleration Time for Servo OFF and Forced Stops (Pn30A)

To specify the Servomotor deceleration time and use it to stop the Servomotor, set Pn30A (Deceleration Time for Servo OFF and Forced Stops).

Deceleration Time for Servo OFF and Forced Stops

	Setting Range	Setting Unit	Default Setting	When Enabled	Classification
Pn30A	0 to 10,000	1 ms	0	Immediately	Setup

(applies to Speed Control and Position Control)

If you set Pn30A to 0, the Servomotor will be stopped with a zero speed.

The deceleration time that you set in Pn30A is the time to decelerate the Servomotor from the maximum motor speed.

Overheat Protection > Connecting the Overheat Protection Input (TH) Signal

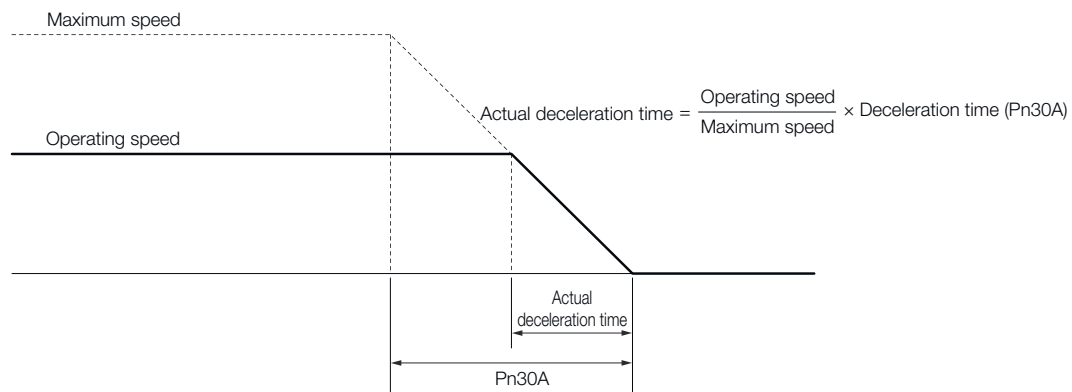


Fig. 197: Pn30A - Deceleration Time for Servo OFF and Forced Stops

7.14.4 Resetting Method for Forced Stops

This section describes the reset methods that can be used after stopping operation for an FSTP (Forced Stop Input) signal.

If the FSTP (Forced Stop Input) signal is OFF and the Servo ON command (Enable Operation command) is input, the forced stop state will be maintained even after the FSTP signal is turned ON.

Send the Servo OFF command (Disable Operation command) to place the SERVOPACK in the base block (BB) state and then send the Servo ON command (Enable Operation command).

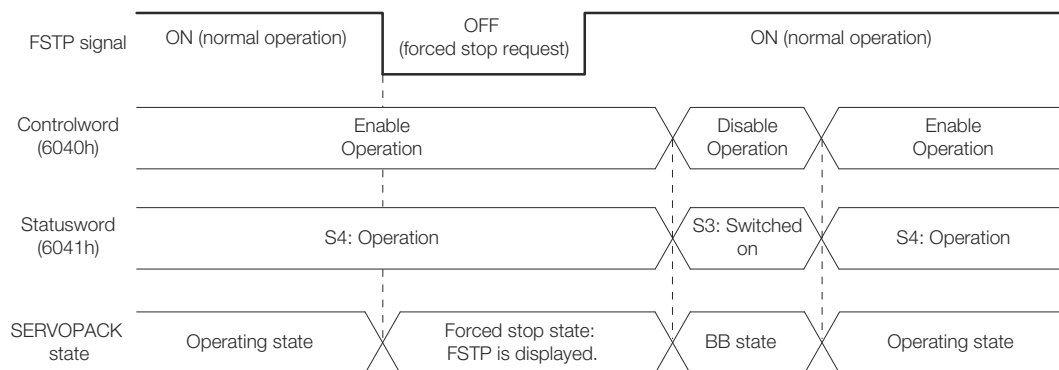


Fig. 198: Resetting Method for Forced Stops

7.15 Overheat Protection

7.15.1 Overview

Overheat protection detects an A.93B warning (Overheat Warning) and an A.862 alarm (Overheat Alarm) by monitoring the overheat protection input signal (TH) from a Yaskawa SGLFW2 Linear Servomotor or from a sensor attached to the machine.

SERVOPACKs with software version 0023 or higher support overheat protection.

When you use overheat protection, you must wire the overheat protection input (TH) signal and select overheat protection (Pn61A = n.□□□X).

7.15.2 Connecting the Overheat Protection Input (TH) Signal

To use overheat protection, you must connect an overheat protection input (TH) signal to the SERVOPACK. This section describes the connection methods for the overheat protection input (TH) signal.

Using Overheat Protection in the Linear Servomotor

- If you use a Serial Converter Unit, connect the connector for the polarity sensor and thermostat cable of the Linear Servomotor to the Serial Converter Unit.
- If you do not use a Serial Converter Unit, connect the thermostat cable of the Linear Servomotor to CN1-5.

Using Overheat Protection for the Machine

To use overheat protection for the machine, connect the overheat protection input (an analog voltage input) from the sensor mounted to the machine to the CN1-5.

7.15.3 Overheat Protection Selections

The overheat protection function is selected with Pn61A = n.□□□X (Overheat Protection Selections).

Parameter	Meaning	When Enabled	Classification
Pn61A	n.□□□0 (default setting)	After restart	Setup
	n.□□□1		
	n.□□□2		
	n.□□□3		

* The SGLFW2 is the only YASKAWA Linear Servomotor that supports this function.

Using Overheat Protection in the YASKAWA Linear Servomotor

To use the overheat protection in a YASKAWA Linear Servomotor (SGLFW2), set Pn61A to n.□□□1.

An A.93B warning (Overheat Warning) will be detected if the overheat protection input (TH) signal from the YASKAWA SGLFW2 Linear Servomotor exceeds the warning temperature.

An A.862 alarm (Overheat Alarm) will be detected if the overheat protection input (TH) signal from the YASKAWA SGLFW2 Linear Servomotor exceeds the alarm temperature.



- If the overheat protection input signal line is disconnected or short-circuited, an A.862 alarm will occur.
- If you set Pn61A to n.□□□1 (Use overheat protection in the YASKAWA Linear Servomotor), the parameters in the Servomotor are enabled and the following parameters are disabled.
 - Overheat Alarm Level (Pn61B)
 - Overheat Warning Level (Pn61C)
 - Overheat Alarm Filter Time (Pn61D)

Monitoring the Machine's Temperature and Using Overheat Protection

Set Pn61A = n.□□□X to 2 or 3 to use overheat protection for the machine.
Set the following parameters as required.

Overheat Alarm Level

	Setting Range	Setting Unit	Default Setting	When Enabled	Classification
Pn61B	0 to 500	0.01 V	250	Immediately	Setup

(applies to Speed Control, Position Control and Torque Control)

Overheat Warning Level

	Setting Range	Setting Unit	Default Setting	When Enabled	Classification
Pn61C	0 to 100	1%	100	Immediately	Setup

(applies to Speed Control, Position Control and Torque Control)

Overheat Alarm Filter Time

	Setting Range	Setting Unit	Default Setting	When Enabled	Classification
Pn61D	0 to 65,535	1 s	0	Immediately	Setup

(applies to Speed Control, Position Control and Torque Control)



- When Pn61A is set to n. □□□2, an A.862 alarm will occur if the overheat protection input signal line is disconnected or short-circuited.
- When Pn61A is set to n. □□□3, an A.862 alarm will not occur if the overheat protection input signal line is disconnected or short-circuited. To ensure safety, we recommend that you connect the external circuits so that you can use a negative voltage input for the overheat protection input (an analog voltage input).

8 Trial Operation and Actual Operation

8.1 Overview

This chapter provides information on the flow and procedures for trial operation and convenient functions to use during trial operation.

8.2 Flow of Trial Operation

8.2.1 Flow of Trial Operation for Rotary Servomotors

The procedure for trial operation is given below.

Preparations for Trial Operation

1. Installation

Install the Servomotor and SERVOPACK according to the installation conditions. First, operation is checked with no load. Do not connect the Servomotor to the machine.

→ [Chap. 4.1 'SERVOPACK Installation' ...page 74](#)

2. Wiring and Connections

Wire and connect the SERVOPACK. First, Servomotor operation is checked without a load. Do not connect the CN1 connector on the SERVOPACK.

→ [Chap. 5.1 'Wiring and Connecting SERVOPACKs' ...page 83](#)

3. Confirmations before Trial Operation

→ [Chap. 8.3 'Inspections and Confirmations before Trial Operation' ...page 255](#)

4. Power ON

5. Resetting the Absolute Encoder

This step is necessary only for a Servomotor with an Absolute Encoder.

→ [Chap. 6.16.1 'Resetting the Absolute Encoder' ...page 179](#)

Trial Operation

1. Trial Operation for the Servomotor without a Load

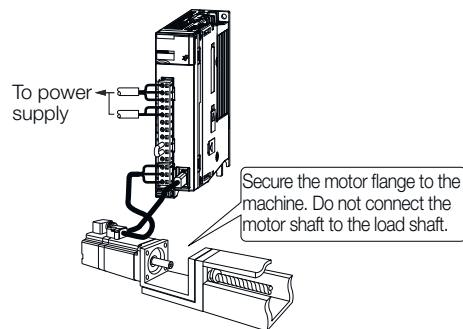


Fig. 199: Trial Operation for Rotary Servomotors - Step 1

→ [Chap. 8.4.1 'Trial Operation for the Servomotor without a Load' ...page 255](#)

2. Trial Operation with PROFINET Communications

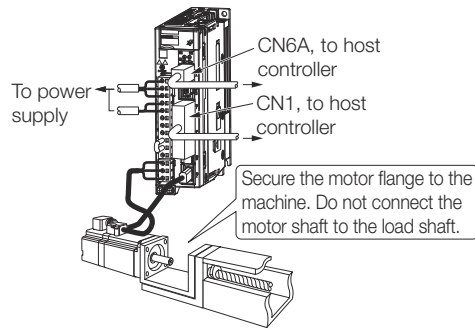


Fig. 200: Trial Operation for Rotary Servomotors - Step 2

➔ [↪ Chap. 8.5 'Trial Operation with PROFINET Communications' ...page 260](#)

3. Trial Operation with the Servomotor Connected to the Machine

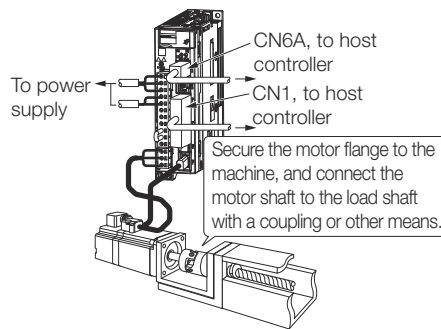


Fig. 201: Trial Operation for Rotary Servomotors - Step 3

➔ [↪ Chap. 8.6.1 'Trial Operation with the Servomotor Connected to the Machine' ...page 262](#)

8.2.2 Flow of Trial Operation for Linear Servomotors

The procedure for trial operation is given below.

Preparations for Trial Operation

1. Installation

Install the Servomotor and SERVOPACK according to the installation conditions. First, operation is checked with no load. Do not connect the Servomotor to the machine.

↪ [Chap. 4.1 'SERVOPACK Installation' ...page 74](#)

2. Wiring and Connections

Wire and connect the SERVOPACK. First, Servomotor operation is checked without a load. Do not connect the CN1 connector on the SERVOPACK.

↪ [Chap. 5.1 'Wiring and Connecting SERVOPACKs' ...page 83](#)


3. Confirmations before Trial Operation

↪ [Chap. 8.3 'Inspections and Confirmations before Trial Operation' ...page 255](#)

4. Power ON

5.  Setting Parameters in the SERVOPACK

Step	No. of Parameter to Set	Description	Remarks	Reference
5-1	Pn282	Linear Encoder Pitch	Set this parameter only if you are using a Serial Converter Unit.	↪ Chap. 6.6 'Setting the Linear Encoder Pitch' ...page 142
5-2	–	Writing Parameters to the Linear Servomotor	Set this parameter only if you are not using a Serial Converter Unit.	↪ Chap. 6.7 'Writing Linear Servomotor Parameters' ...page 143
5-3	Pn080 = n.□□X□	Motor Phase Sequence Selection	–	↪ Chap. 6.8 'Selecting the Phase Sequence for a Linear Servomotor' ...page 150
5-4	Pn080 = n.□□□X	Polarity Sensor Selection	–	↪ Chap. 6.9 'Polarity Sensor Setting' ...page 152
5-5	–	Polarity Detection	This step is necessary only for a Linear Servomotor without a Polarity Sensor.	↪ Chap. 6.10.1 'Polarity Detection' ...page 152
5-6	Pn50A = n.X□□□ and Pn50B = n.□□□X	Overtravel Signal Allocations	–	↪ Chap. 6.11.1 'Overtravel and Related Settings' ...page 155
5-7	Pn483, Pn484	Force Control	–	↪ Chap. 7.8.1 'Selecting Torque Limits' ...page 212

6.  Setting the Origin of the Absolute Linear Encoder

[↪ Chap. 6.17.2 'Setting the Origin of the Absolute Linear Encoder' ...page 183](#)

Trial Operation

1. Trial Operation for the Servomotor without a Load

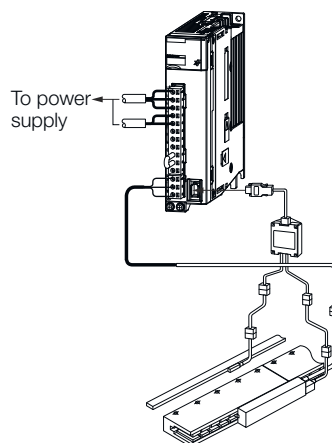


Fig. 202: Trial Operation for Linear Servomotors - Step 1

➔ ➔ [Chap. 8.4.1 'Trial Operation for the Servomotor without a Load' ...page 255](#)

2. Trial Operation with PROFINET Communications

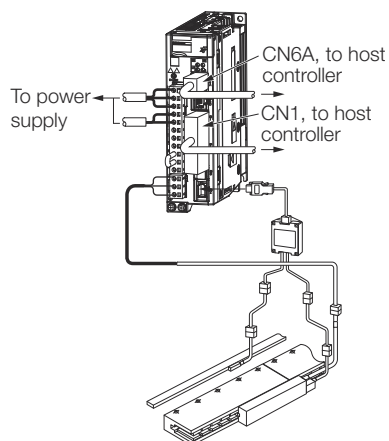


Fig. 203: Trial Operation for Linear Servomotors - Step 2

➔ ➔ [Chap. 8.5 'Trial Operation with PROFINET Communications' ...page 260](#)

3. Trial Operation with the Servomotor Connected to the Machine

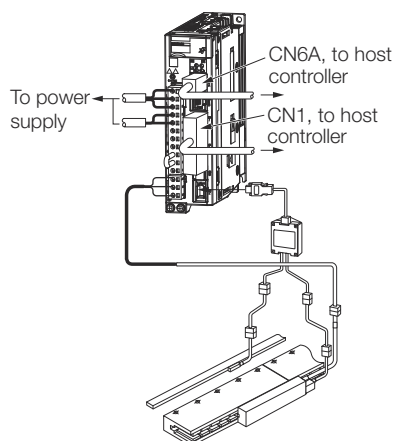


Fig. 204: Trial Operation for Linear Servomotors - Step 3

➔ ➔ [Chap. 8.6.1 'Trial Operation with the Servomotor Connected to the Machine' ...page 262](#)

8.3 Inspections and Confirmations before Trial Operation

To ensure safe and correct trial operation, check the following items before you start trial operation.

- Make sure that the SERVOPACK and Servomotor are installed, wired, and connected correctly.
- Make sure that the correct power supply voltage is supplied to the SERVOPACK.
- Make sure that there are no loose parts in the Servomotor mounting.
- If you are using a Servomotor with an Oil Seal, make sure that the oil seal is not damaged. Also make sure that oil has been applied.
- If you are performing trial operation on a Servomotor that has been stored for a long period of time, make sure that all Servomotor inspection and maintenance procedures have been completed.

Refer to the manual for your Servomotor for Servomotor maintenance and inspection information.

- If you are using a Servomotor with a Holding Brake, make sure that the brake is released in advance. To release the brake, you must apply the specified voltage of 24 VDC to the brake. A circuit example for trial operation is provided below.

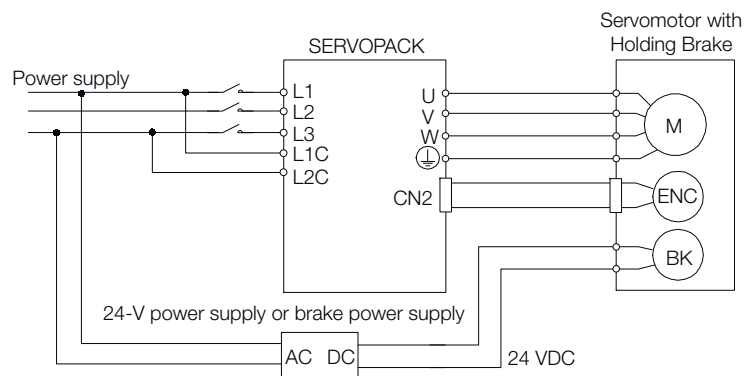


Fig. 205: Trial Operation - Releasing the Holding Brake

8.4 Trial Operation for the Servomotor without a Load

8.4.1 Overview

You use jogging for trial operation of the Servomotor without a load.

Jogging is used to check the operation of the Servomotor without connecting the SERVOPACK to the host controller. The Servomotor is moved at the preset jogging speed.



CAUTION

During jogging, the overtravel function is disabled. Consider the range of motion of your machine when you jog the Servomotor.



The tuning-less function is enabled as the default setting. When the tuning-less function is enabled, gain will increase and vibration may occur if the Servomotor is operated with no load. If vibration occurs, disable the tuning-less function (Pn170 = n. □□□0).

8.4.2 Preparations

Confirm the following conditions before you jog the Servomotor.

Trial Operation for the Servomotor without a Load > Preparations

- The parameters must not be write prohibited.
- The main circuit power supply must be ON.
- There must be no alarms.
- There must be no hard wire base block (HWBB).
- The servo must be OFF.
- The jogging speed must be set considering the operating range of the machine.
The jogging speed is set with the following parameters.

Rotary Servomotors

Jogging Speed

	Setting Range	Setting Unit	Default Setting	When Enabled	Classification
Pn304	0 to 10,000	1 min ⁻¹	500	Immediately	Setup

(applies to Speed Control, Position Control and Torque Control)

Soft Start Acceleration Time

	Setting Range	Setting Unit	Default Setting	When Enabled	Classification
Pn305	0 to 10,000	1 ms	0	Immediately	Setup

(applies to Speed Control)

Soft Start Deceleration Time

	Setting Range	Setting Unit	Default Setting	When Enabled	Classification
Pn306	0 to 10,000	1 ms	0	Immediately	Setup

(applies to Speed Control)

Direct Drive Servomotors

Jogging Speed

	Setting Range	Setting Unit	Default Setting	When Enabled	Classification
Pn304	0 to 10,000	0.1 min ⁻¹	500	Immediately	Setup

(applies to Speed Control, Position Control and Torque Control)

Soft Start Acceleration Time

	Setting Range	Setting Unit	Default Setting	When Enabled	Classification
Pn305	0 to 10,000	1 ms	0	Immediately	Setup

(applies to Speed Control)

Soft Start Deceleration Time

	Setting Range	Setting Unit	Default Setting	When Enabled	Classification
Pn306	0 to 10,000	1 ms	0	Immediately	Setup

(applies to Speed Control)

Linear Servomotors

Jogging Speed

	Setting Range	Setting Unit	Default Setting	When Enabled	Classification
Pn383	0 to 10,000	1 mm/s	50	Immediately	Setup

(applies to Speed Control, Position Control and Torque Control)

Soft Start Acceleration Time

	Setting Range	Setting Unit	Default Setting	When Enabled	Classification
Pn305	0 to 10,000	1 ms	0	Immediately	Setup

(applies to Speed Control)


Soft Start Deceleration Time

	Setting Range	Setting Unit	Default Setting	When Enabled	Classification
Pn306	0 to 10,000	1 ms	0	Immediately	Setup

(applies to Speed Control)




8.4.3 Applicable Tools

The following table lists the tools that you can use to perform jogging and the applicable tool functions.

Tool	Function	Operating Procedure Reference
Digital Operator	Fn002	 Σ -7-Series Digital Operator Operating Manual (Manual No.: SIEP S800001 33)
SigmaWin+	Test Run - Jog	↪ Chap. 8.4.4 'Operating Procedure' ...page 257

8.4.4 Operating Procedure

Use the following procedure to jog the motor.

1.  Click the  Servo Drive Button in the workspace of the Main Window of the SigmaWin+.
2.  Select JOG Operation in the Menu Dialog Box.
 - ➔ The Jog Operation Dialog Box will be displayed.

3. → Read the warnings and then click the OK Button.

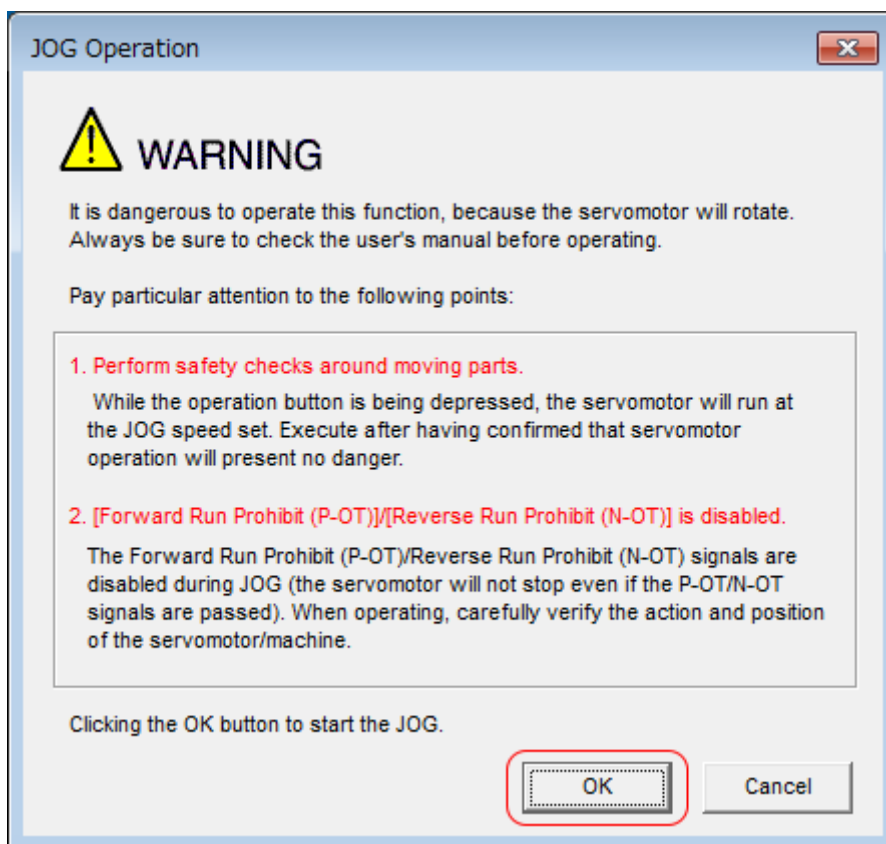


Fig. 206: JOG Operation - Warning

4. → Check the jogging speed and then click the **Servo ON** Button.

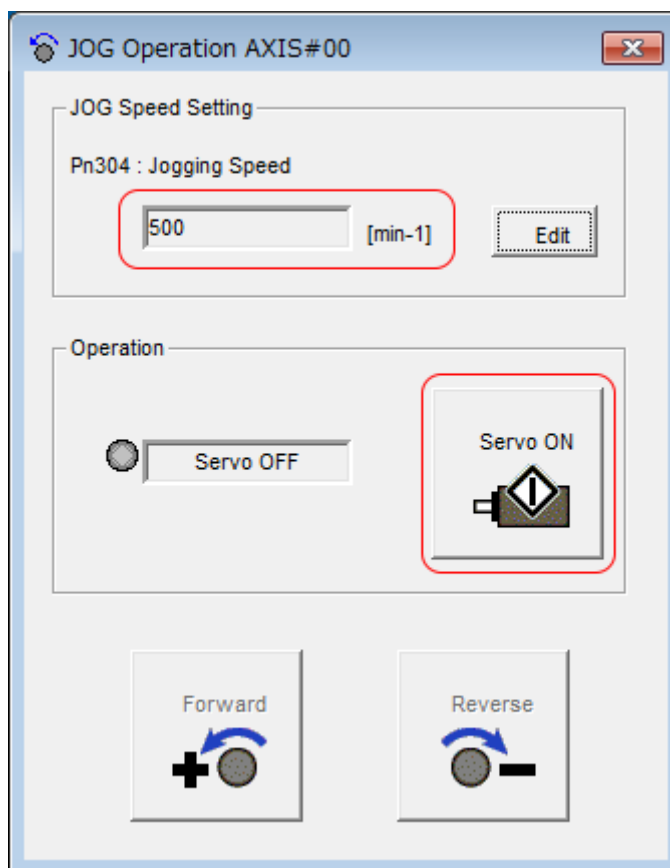


Fig. 207: JOG Operation - JOG Speed Setting

- ➔ The display in the **Operation Area** will change to **Servo ON**.



To change Information the speed, click the **Edit** Button and enter the new speed.

5. → Click the **Forward** Button or the **Reverse** Button.

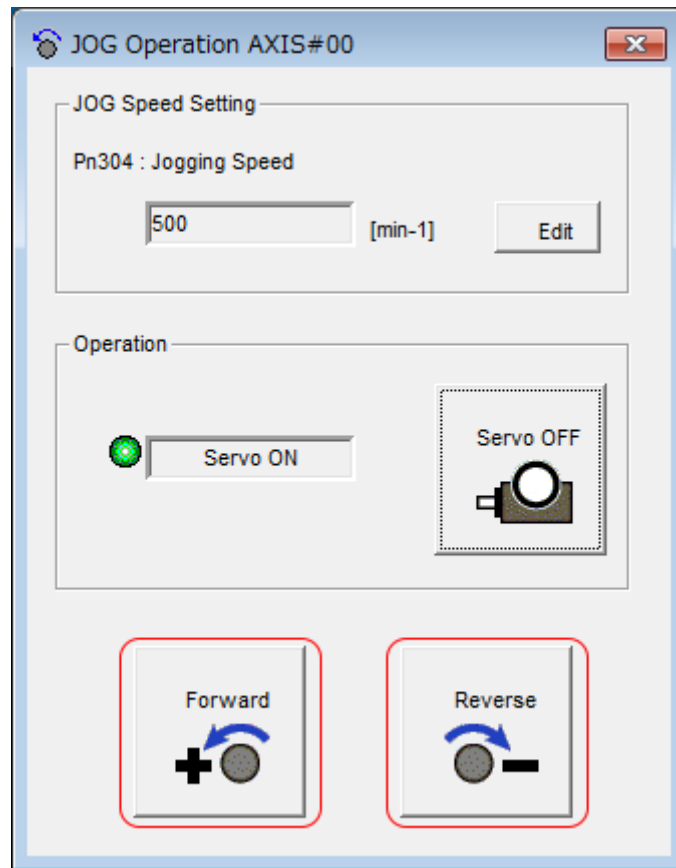


Fig. 208: JOG Operation - Forward - Reverse

- ➔ Jogging will be performed only while you hold down the mouse button.

6. → After you finish jogging, turn the power supply to the SERVOPACK OFF and ON again.

This concludes the jogging procedure.

8.5 Trial Operation with PROFINET Communications

A trial operation example for PROFINET communications is given below.

In this example, operation in PROFIdrive Position Mode is described.

The default positioning mode is relative positioning. For PROFINET communication, the YASKAWA telegram 100 is used.



The configuration of the PLC is not part of the description below. The drive has to be configured with module "Telegram 100".

Refer to the following chapter for details on operation with PROFINET communications.

➔ [Chap. 14.1 'PROFIdrive Drive Profile' ...page 472](#)

1. → Confirm that the wiring is correct, and then connect the I/O signal connector (CN1) and PROFINET communications connector (CN6A).

Refer to the following chapter for details on wiring.

➔ [Chap. 5.1 'Wiring and Connecting SERVOPACKs' ...page 83](#)

2. → Turn ON the power supplies to the SERVOPACK.
If power is being supplied correctly, the CHARGE indicator on the SERVOPACK will light.
3. → Assign the same Device Name as configured in the PLC.
4. → Set the PLC to RUN state.
Refer to the following chapter for details on the PROFINET communications status.
→ [Chap. 14.1 'Device Control' ...page 472](#)
5. → Set the Telegram Selection (PNU 922) to Telegram 100. The parameter is only accepted after a restart.
→ [Chap. 13.6.6 'YASKAWA Telegram \(Telegram 100\)' ...page 467](#)
6. → Set the Modes of Operation (6060h) to PROFIdrive Position Mode.
Refer to the following section for details on modes of operation.
→ ['Modes of Operation' ...page 520](#)
Note that Modes of Operation is mapped into the cyclic data.



*Change the values of the objects in the cyclic data (PZDs).
Parameter requests to objects mapped in cyclic data will not have the expected result because these are overwritten by the cyclic data (PZDs).*

7. → Change the *Controlword (STW1) (6040h)* to supply power to the motor.
→ ['Controlword \(STW1\)' ...page 512](#)
When the *Statusword (ZSW1) (6041h)* shows the Operation state, power is supplied to the motor.
→ ['Statusword \(ZSW1\)' ...page 514](#)



*Change the values of the objects in the cyclic data (PZDs).
Parameter requests to objects mapped in cyclic data will not have the expected result because these are overwritten by the cyclic data (PZDs).*

8. → Set *Traversing Block Selection (2532h)* to MDI submode.
→ ['Traversing Block Selection \(SATZANW\)' ...page 524](#)



*Change the values of the objects in the cyclic data (PZDs).
Parameter requests to objects mapped in cyclic data will not have the expected result because these are overwritten by the cyclic data (PZDs).*


9. → Set *Target Position (607Ah)*, *Profile Velocity (6081h)*, *Profile Acceleration (6083h)*, and *Profile Deceleration (6084h)*, and then manipulate *Controlword (STW1) (6040h)* to start positioning.



*Change the values of the objects in the cyclic data (PZDs).
Parameter requests to objects mapped in cyclic data will not have the expected result because these are overwritten by the cyclic data (PZDs).*

10. While operation is in progress for step 9, confirm the following items.

Confirmation Item	Reference
Confirm that the rotational direction of the Servomotor agrees with the forward or reverse reference. If they do not agree, correct the rotation direction of the Servomotor.	→ Chap. 6.5 'Motor Direction Setting' ...page 141
Confirm that no abnormal vibration, noise, or temperature rise occurs. If any abnormalities are found, implement corrections.	→ Chap. 16.6 'Troubleshooting Based on the Operation and Conditions of the Servomotor' ...page 609


 *If the load machine is not sufficiently broken in before trial operation, the Servomotor may become overloaded.*


8.6 Trial Operation with the Servomotor Connected to the Machine

8.6.1 Overview

This section provides the procedure for trial operation with both the machine and Servomotor.

8.6.2 Precautions

 **WARNING**
 Operating mistakes that occur after the Servomotor is connected to the machine may not only damage the machine, but they may also cause accidents resulting in personal injury.

 *If you disabled the overtravel function for trial operation of the Servomotor without a load, enable the overtravel function (P-OT and N-OT signal) before you perform trial operation with the Servomotor connected to the machine in order to provide protection.*

If you will use a holding brake, observe the following precautions during trial operation.

- Before you check the operation of the brake, implement measures to prevent the machine from falling due to gravity and to prevent vibration from being caused by an external force.
- First check the Servomotor operation and brake operation with the Servomotor uncoupled from the machine. If no problems are found, connect the Servomotor to the machine and perform trial operation again.

Control the operation of the brake with the /BK (Brake) signal output from the SERVOPACK.

Refer to the following sections for information on wiring and the related parameter settings.

→ Chap. 5.5.4 'Wiring the SERVOPACK to the Holding Brake' ...page 112

→ Chap. 6.12.1 'Holding Brake' ...page 161



Failures caused by incorrect wiring or incorrect voltage application in the brake circuit may cause the SERVOPACK to fail, damage the SERVOPACK, damage the equipment, or cause an accident resulting in death or injury.

Observe the precautions and instructions for wiring and trial operation precisely as described in this manual.

8.6.3 Preparations

Confirm the following items before you perform the trial operation procedure for both the machine and Servomotor.

- Make sure that the procedure described in [↪ Chap. 8.5 'Trial Operation with PROFINET Communications' ...page 260](#) has been completed.
- Make sure that the SERVOPACK is connected correctly to both the host controller and the peripheral devices.
 - Safety Function Wiring
If you are not using the safety function, leave the Safety Jumper Connector (provided as an accessory with the SERVOPACK) connected to CN8.
If you are using the safety function, remove the Safety Jumper Connector from CN8 and connect the safety function device.
 - Overtravel wiring
 - Brake wiring
 - Allocation of the /BK (Brake) signal to a pin on the I/O signal connector (CN1)
 - Emergency stop circuit wiring
 - Host controller wiring

8.6.4 Operating Procedure

- 1.** Enable the overtravel signals.
[↪ Chap. 6.11.3 'Setting to Enable/Disable Overtravel' ...page 157](#)
- 2.** Make the settings for the protective functions, such as the safety function, overtravel, and the brake.
[↪ Chap. 5.7.1 'Connecting Safety Function Signals' ...page 120](#)
[↪ Chap. 6.11.1 'Overtravel and Related Settings' ...page 155](#)
[↪ Chap. 6.12.1 'Holding Brake' ...page 161](#)
- 3.** Turn OFF the power supplies to the SERVOPACK.
 - ➔ The control power supply and main circuit power supply will turn OFF.

4. → Couple the Servomotor to the machine.

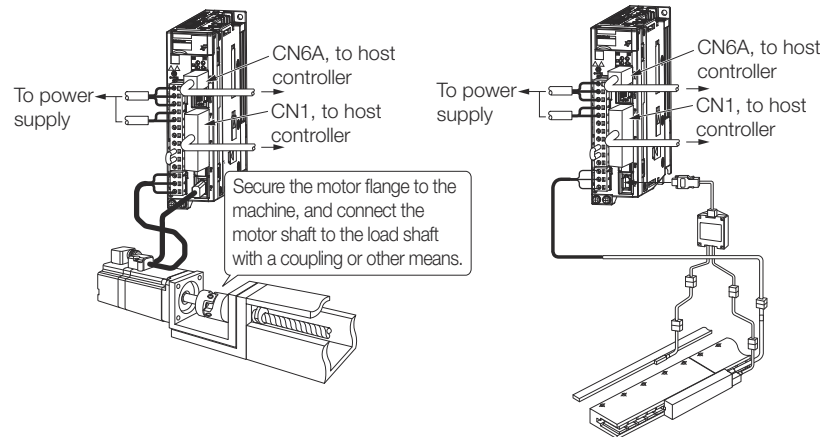


Fig. 209: Trial Operation - Coupling the Servomotor to the machine

5. → Turn ON the power supplies to the machine and host controller and turn ON the control power supply and main circuit power supply to the SERVOPACK.

6. → Check the protective functions, such as overtravel and the brake, to confirm that they operate correctly.

Enable activating an emergency stop so that the Servomotor can be stopped safely should an error occur during the remainder of the procedure.

7. → Perform trial operation according to → [Chap. 8.5 'Trial Operation with PROFINET Communications' ...page 260](#) and confirm that the same results are obtained as when trial operation was performed on the Servomotor without a load.

8. → If necessary, adjust the servo gain to improve the Servomotor response characteristics.

The Servomotor and machine may not be broken in completely for the trial operation. Therefore, let the system run for a sufficient amount of time to ensure that it is properly broken in.

9. → For future maintenance, save the parameter settings with one of the following methods.

- Use the SigmaWin+ to save the parameters as a file.
- Use the Parameter Copy Mode of the Digital Operator.
- Record the settings manually.

This concludes the procedure for trial operation with both the machine and Servomotor.

8.7 Convenient Function to Use during Trial Operation

8.7.1 Overview

This section describes some convenient operations that you can use during trial operation. Use them as required.

8.7.2 Program Jogging

You can use program jogging to perform continuous operation with a preset operation pattern, travel distance, movement speed, acceleration/deceleration time, waiting time, and number of movements.

You can use this operation when you set up the system in the same way as for normal jogging to move the Servomotor without connecting it to the host controller in order to check Servomotor operation and execute simple positioning operations.

Preparations

Confirm the following conditions before you perform program jogging.

- The parameters must not be write prohibited.
- The main circuit power supply must be ON.
- There must be no alarms.
- There must be no hard wire base block (HWBB).
- The servo must be OFF.
- The range of machine motion and the safe movement speed of your machine must be considered when you set the travel distance and movement speed.
- There must be no overtravel.

Additional Information

- You can use the functions that are applicable to position control. However, parameters related to motion control through PROFINET communications are disabled.
- The overtravel function is enabled.
- The software limits are disabled.

Program Jogging Operation Pattern

An example of a program jogging operation pattern is given below. In this example, the Servomotor direction is set to Pn000 = n.□□□0 (Use CCW as the forward direction).

Setting of Pn530	Setting	Operation Pattern
n.□□□0	(Waiting time → Forward travel distance) × Number of movements	<p>Number of movements (Pn536)</p> <p>Movement speed • Rotary Servomotor: Pn533 • Linear Servomotor: Pn585</p> <p>Speed 0</p> <p>Travel distance (Pn531)</p> <p>Waiting time (Pn535)</p> <p>Acceleration/-deceleration time (Pn534)</p>
n.□□□1	(Waiting time → Reverse by travel distance) × Number of movements	<p>Number of movements (Pn536)</p> <p>Speed 0</p> <p>Movement speed • Rotary Servomotor: Pn533 • Linear Servomotor: Pn585</p> <p>Travel distance (Pn531)</p> <p>Waiting time (Pn535)</p> <p>Acceleration/-deceleration time (Pn534)</p>
n.□□□2	(Waiting time → Forward by travel distance) × Number of movements → (Waiting time → Reverse by travel distance) × Number of movements	<p>Number of movements (Pn536)</p> <p>Number of movements (Pn536)</p> <p>Speed 0</p> <p>Movement speed • Rotary Servomotor: Pn533 • Linear Servomotor: Pn585</p> <p>Travel distance (Pn531)</p> <p>Waiting time (Pn535)</p> <p>Acceleration/-deceleration time (Pn534)</p> <p>Travel distance (Pn531)</p> <p>Waiting time (Pn535)</p> <p>Travel distance (Pn531)</p> <p>Waiting time (Pn535)</p> <p>Travel distance (Pn531)</p>

Convenient Function to Use during Trial Operation > Program Jogging

Setting of Pn530	Setting	Operation Pattern
n.□□□3	(Waiting time → Reverse by travel distance) × Number of movements → (Waiting time → Forward by travel distance) × Number of movements	<p>Number of movements (Pn536)</p> <p>Speed 0</p> <p>Waiting time (Pn535)</p> <p>Acceleration/-deceleration time (Pn534)</p> <p>Travel distance (Pn531)</p> <p>Movement speed • Rotary Servomotor: Pn533 • Linear Servomotor: Pn585</p>
n.□□□4	(Waiting time → Forward by travel distance → Reverse by travel distance) × Number of movements	<p>Number of movements (Pn536)</p> <p>Speed 0</p> <p>Waiting time (Pn535)</p> <p>Acceleration/-deceleration time (Pn534)</p> <p>Travel distance (Pn531)</p> <p>Movement speed • Rotary Servomotor: Pn533 • Linear Servomotor: Pn585</p>
n.□□□5	(Waiting time → Reverse by travel distance → Waiting time → Forward by travel distance) × Number of movements	<p>Number of movements (Pn536)</p> <p>Speed 0</p> <p>Waiting time (Pn535)</p> <p>Acceleration/-deceleration time (Pn534)</p> <p>Travel distance (Pn531)</p> <p>Movement speed • Rotary Servomotor: Pn533 • Linear Servomotor: Pn585</p>



If Pn530 is set to n.□□□0, n.□□□1, n.□□□4, or n.□□□5, you can set Pn536 (Program Jogging Number of Movements) to 0 to perform infinite time operation.

You cannot use infinite time operation if Pn530 is set to n.□□□2 or n.□□□3.

If you perform infinite time operation from the Digital Operator, press the JOG/SVON Key to turn OFF the servo to end infinite time operation.

Related Parameters

Use the following parameters to set the program jogging operation pattern. Do not change the settings while the program jogging operation is being executed.

- Rotary Servomotors

Program Jogging-Related Selections

	Setting Range	Setting Unit	Default Setting	When Enabled	Classification
Pn530	0000 to 0005	-	0000	Immediately	Setup

(applies to Speed Control, Position Control and Torque Control)

Program Jogging Travel Distance

	Setting Range	Setting Unit	Default Setting	When Enabled	Classification
Pn531	1 to 1,073,741,824	1 reference unit	32,768	Immediately	Setup

(applies to Speed Control, Position Control and Torque Control)

Program Jogging Movement Speed

	Setting Range	Setting Unit	Default Setting	When Enabled	Classification
Pn533	1 to 10,000	1 min ⁻¹	500	Immediately	Setup

(applies to Speed Control, Position Control and Torque Control)

Program Jogging Acceleration/Deceleration Time

	Setting Range	Setting Unit	Default Setting	When Enabled	Classification
Pn534	2 to 10,000	1 ms	100	Immediately	Setup

(applies to Speed Control, Position Control and Torque Control)

Program Jogging Waiting Time

	Setting Range	Setting Unit	Default Setting	When Enabled	Classification
Pn535	0 to 10,000	1 ms	100	Immediately	Setup

(applies to Speed Control, Position Control and Torque Control)

Program Jogging Number of Movements

	Setting Range	Setting Unit	Default Setting	When Enabled	Classification
Pn536	0 to 1,000	1	1	Immediately	Setup

(applies to Speed Control, Position Control and Torque Control)

- Direct Drive Servomotors

Program Jogging-Related Selections

	Setting Range	Setting Unit	Default Setting	When Enabled	Classification
Pn530	0000 to 0005	–	0000	Immediately	Setup

(applies to Speed Control, Position Control and Torque Control)

Program Jogging Travel Distance

	Setting Range	Setting Unit	Default Setting	When Enabled	Classification
Pn531	1 to 1,073,741,824	1 reference unit	32,768	Immediately	Setup

(applies to Speed Control, Position Control and Torque Control)

Convenient Function to Use during Trial Operation > Program Jogging

Program Jogging Movement Speed

	Setting Range	Setting Unit	Default Setting	When Enabled	Classification
Pn533	1 to 10,000	0.1 min ⁻¹	500	Immediately	Setup

(applies to Speed Control, Position Control and Torque Control)

Program Jogging Acceleration/Deceleration Time

	Setting Range	Setting Unit	Default Setting	When Enabled	Classification
Pn534	2 to 10,000	1 ms	100	Immediately	Setup

(applies to Speed Control, Position Control and Torque Control)

Program Jogging Waiting Time

	Setting Range	Setting Unit	Default Setting	When Enabled	Classification
Pn535	0 to 10,000	1 ms	100	Immediately	Setup

(applies to Speed Control, Position Control and Torque Control)

Program Jogging Number of Movements

	Setting Range	Setting Unit	Default Setting	When Enabled	Classification
Pn536	0 to 1,000	1	1	Immediately	Setup

(applies to Speed Control, Position Control and Torque Control)

■ Linear Servomotors

Program Jogging-Related Selections

	Setting Range	Setting Unit	Default Setting	When Enabled	Classification
Pn530	0000 to 0005	–	0000	Immediately	Setup

(applies to Speed Control, Position Control and Force Control)

Program Jogging Travel Distance

	Setting Range	Setting Unit	Default Setting	When Enabled	Classification
Pn531	1 to 1,073,741,824	1 reference unit	32,768	Immediately	Setup

(applies to Speed Control, Position Control and Force Control)

Program Jogging Movement Speed

	Setting Range	Setting Unit	Default Setting	When Enabled	Classification
Pn585	1 to 10,000	1 mm/s	50	Immediately	Setup

(applies to Speed Control, Position Control and Force Control)

Program Jogging Acceleration/Deceleration Time

	Setting Range	Setting Unit	Default Setting	When Enabled	Classification
Pn534	2 to 10,000	1 ms	100	Immediately	Setup

(applies to Speed Control, Position Control and Force Control)

Program Jogging Waiting Time

	Setting Range	Setting Unit	Default Setting	When Enabled	Classification
Pn535	0 to 10,000	1 ms	100	Immediately	Setup

(applies to Speed Control, Position Control and Force Control)


Program Jogging Number of Movements

	Setting Range	Setting Unit	Default Setting	When Enabled	Classification
Pn536	0 to 1,000	1	1	Immediately	Setup

(applies to Speed Control, Position Control and Force Control)




Applicable Tools

The following table lists the tools that you can use to perform program jogging and the applicable tool functions.

Tool	Function	Operating Procedure Reference
Digital Operator	Fn004	 Σ -7-Series Digital Operator Operating Manual (Manual No.: SIEP S800001 33)
SigmaWin+	SigmaWin+ Test Run - Program JOG	↪ 'Operating Procedure' ...page 269

Operating Procedure

Use the following procedure for a program jog operation.

1.  Click the  Servo Drive Button in the workspace of the Main Window of the SigmaWin+.
2.  Select **JOG Program** in the Menu Dialog Box.
 - ➔ The Jog Program Dialog Box will be displayed.

Convenient Function to Use during Trial Operation > Program Jogging

3. → Read the warnings and then click the **OK** Button.

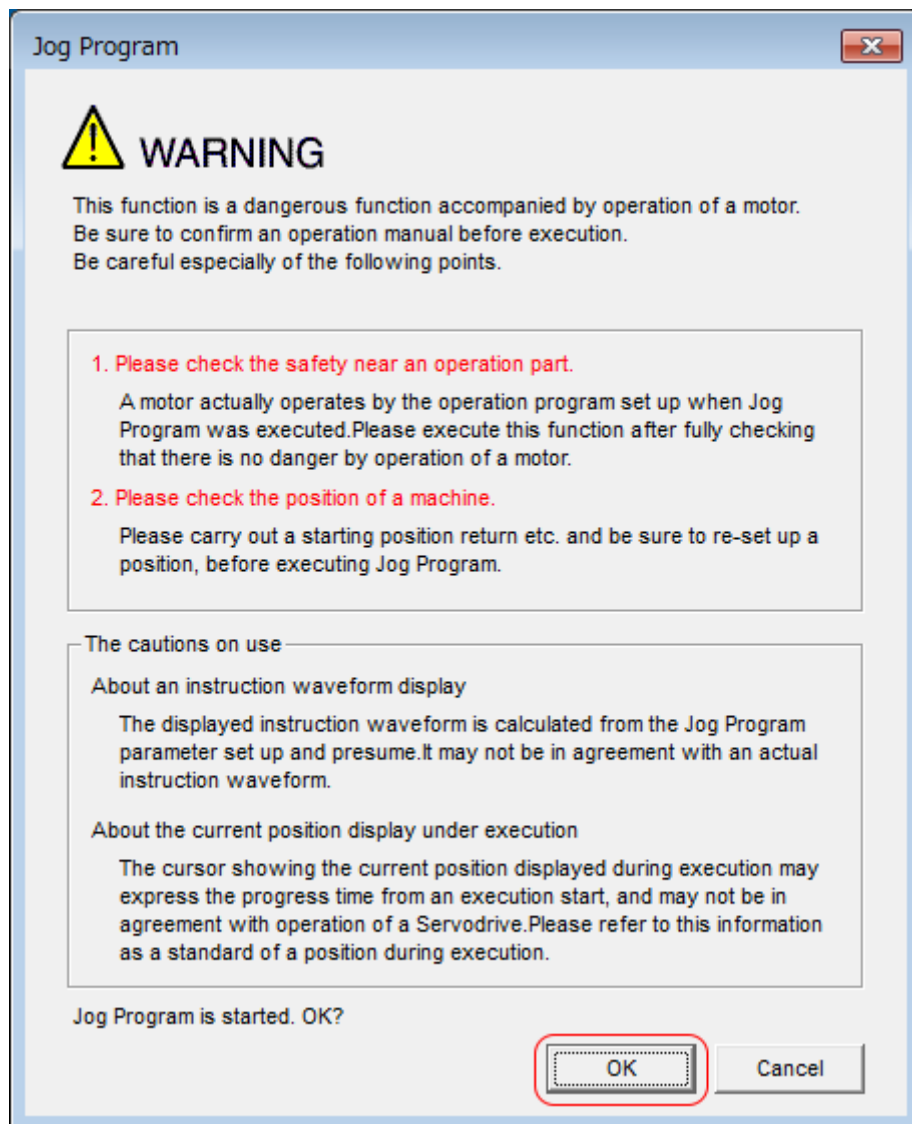


Fig. 210: JOG Program - Warning

4. → Set the operating conditions, click the **Apply** Button, and then click the **Run** Button.
➔ A graph of the operation pattern will be displayed.

Convenient Function to Use during Trial Operation > Program Jogging

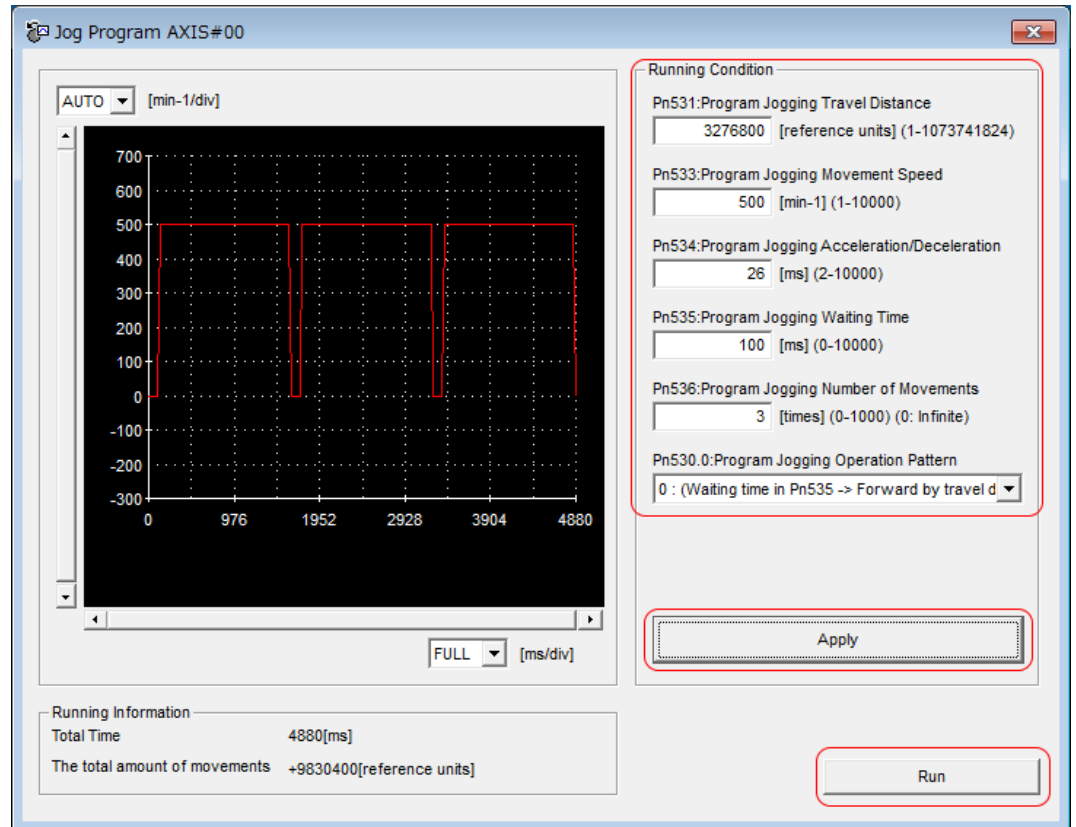


Fig. 211: JOG Program - Running Condition

- Click the **Servo ON** Button and then the **Execute** Button. The program jogging operation will be executed.

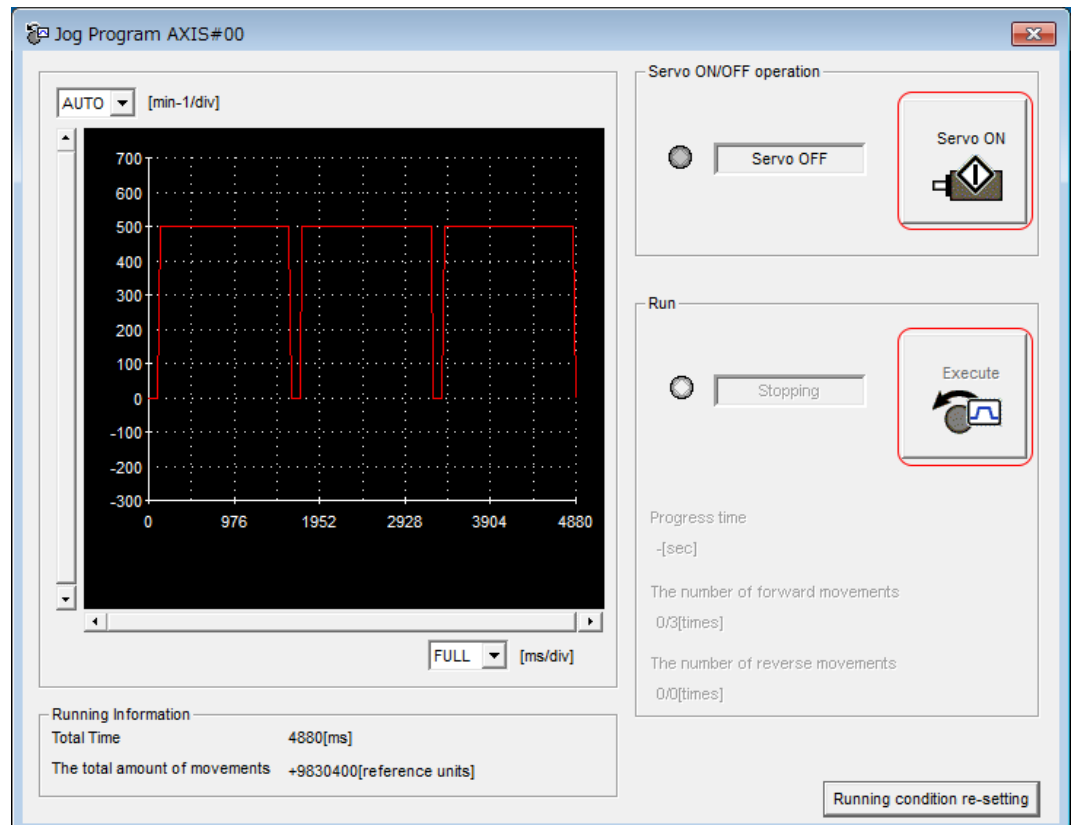


Fig. 212: JOG Program - Servo ON - Execute



CAUTION

Be aware of the following points if you cancel the program jogging operation while the Servomotor is operating.

- If you cancel operation with the **Servo OFF** Button, the Servomotor will stop according to setting of the Servo OFF stopping method (Pn001 = n.□□□X).
- If you cancel operation with the **Cancel** Button, the Servomotor will decelerate to a stop and then enter a zero-clamped state.

This concludes the program jogging procedure.

8.7.3 Origin Search

The origin search operation positions the motor to the origin within one rotation and then clamps it there.



CAUTION

Make sure that the load is not coupled when you execute an origin search.

The Forward Drive Prohibit (P-OT) signal and Reverse Drive Prohibit (N-OT) signal are disabled during an origin search.

Use an origin search when it is necessary to align the origin within one rotation with the machine origin. The following speeds are used for origin searches.

- Rotary Servomotors: 60 min⁻¹
- Direct Drive Servomotors: 6 min⁻¹
- Linear Servomotors: 15 mm/s

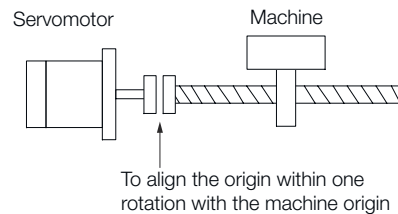


Fig. 213: Origin Search Mode

Preparations

Confirm the following conditions before you start an origin search.

- The parameters must not be write prohibited.
- The main circuit power supply must be ON.
- There must be no alarms.
- There must be no hard wire base block (HWBB).
- The servo must be OFF.

Applicable Tools


The following table lists the tools that you can use to perform an origin search and the applicable tool functions.

Tool	Function	Operating Procedure Reference
Digital Operator	Fn003	📖 Σ-7-Series Digital Operator Operating Manual (Manual No.: SIEP S800001 33)
SigmaWin+*	Setup - Origin Search	➡ <i>'Operating Procedure' ...page 273</i>

* Cannot be used when connecting a Linear Servomotor.

Operating Procedure

Use the following procedure to perform an origin search.

1. Click the  Servo Drive Button in the workspace of the Main Window of the SigmaWin+.
2. Select Search Origin in the Menu Dialog Box.
 - ➔ The Origin Search Dialog Box will be displayed.
3. Read the warnings and then click the OK Button.
 - ➔

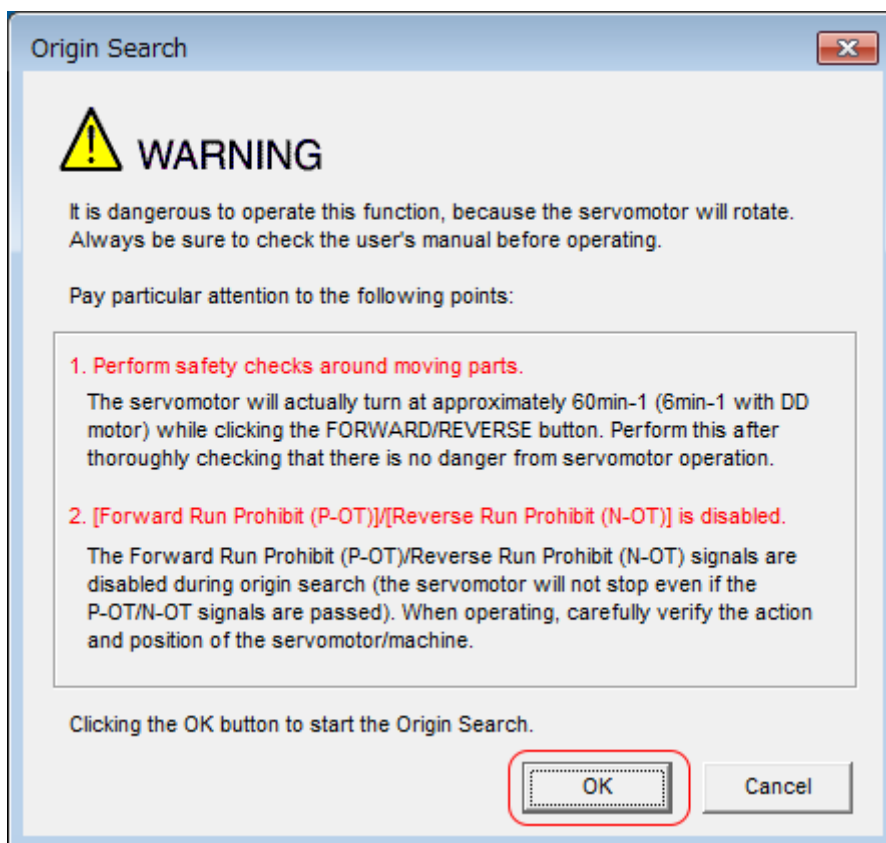


Fig. 214: Origin Search - Warning

Convenient Function to Use during Trial Operation > Origin Search

4. → Click the **Servo ON** Button.

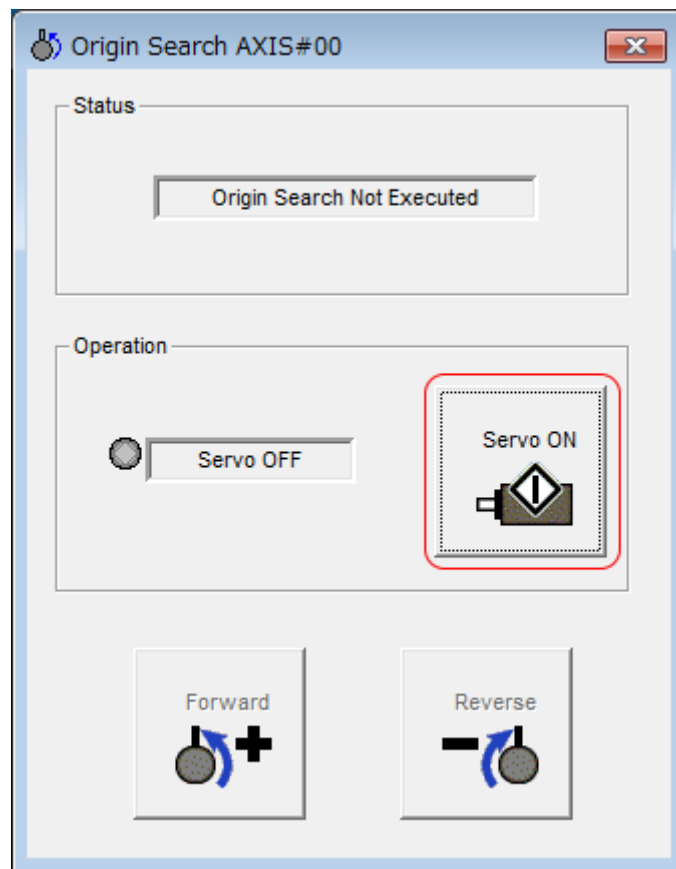


Fig. 215: Origin Search - Servo ON

5. Click the **Forward** Button or the **Reverse** Button.

An origin search will be performed only while you hold down the mouse button. The motor will stop when the origin search has been completed.

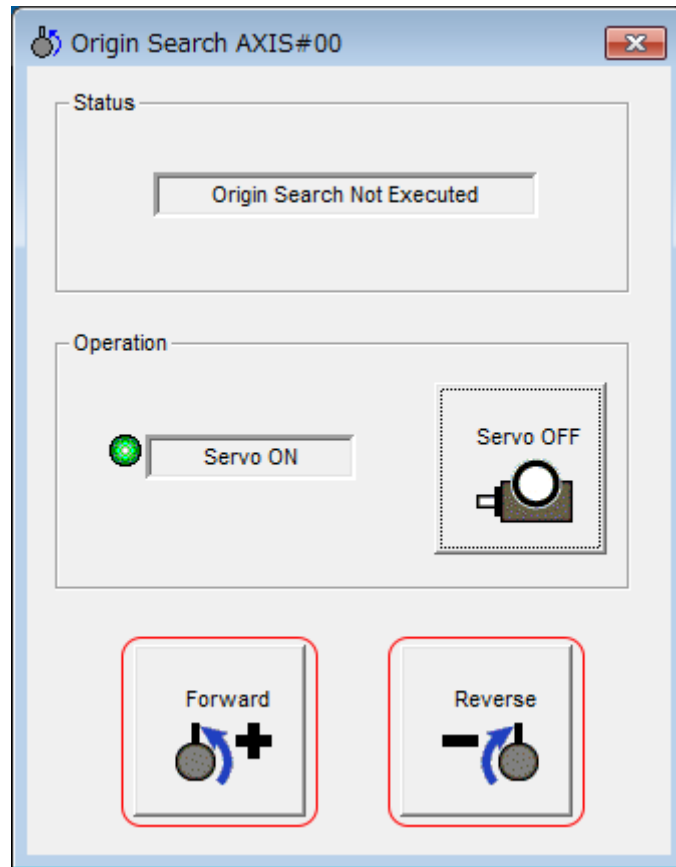


Fig. 216: Origin Search - Forward - Reverse

This concludes the origin search procedure.

8.7.4 Test without a Motor

A test without a motor is used to check the operation of the host controller and peripheral devices by simulating the operation of the Servomotor in the SERVOPACK, i.e., without actually operating a Servomotor. This test allows you to check wiring, debug the system, and verify parameters to shorten the time required for setup work and to prevent damage to the machine that may result from possible malfunctions. The operation of the Servomotor can be checked with this test regardless of whether the Servomotor is actually connected or not.

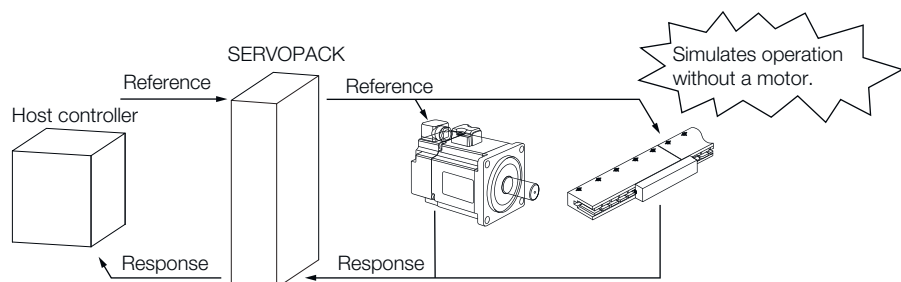


Fig. 217: Test without a Motor

Use Pn00C = n.□□□X to enable or disable the test without a motor.

Convenient Function to Use during Trial Operation > Test without a Motor

Parameter		Meaning	When Enabled	Classification
Pn00C	n.□□□0 (default setting)	Disable tests without a motor.	After restart	Setup
	n.□□□1	Enable tests without a motor.		



An asterisk is displayed on the status display of the Digital Operator while a test without a motor is being executed.

Motor Information and Encoder Information

The motor and encoder information is used during tests without a motor. The source of the information depends on the device connection status.

Rotary Servomotor

Motor Connection Status	Information That Is Used	Source of Information
Connected	Motor information	Information in the Servomotor that is connected
	Encoder information <ul style="list-style-type: none"> Encoder resolution Encoder type 	
Not connected	Motor information <ul style="list-style-type: none"> Rated motor speed Maximum motor speed 	<ul style="list-style-type: none"> Setting of Pn000 = n.X□□□ (Rotary/Linear Startup Selection When Encoder Is Not Connected) Rated motor speed and maximum motor speed The values previously saved in the SERVOPACK will be used for the rated motor speed and maximum motor speed. Use the monitor displays (Un020: Rated Motor Speed and Un021: Maximum Motor Speed) to check the values.
	Encoder information <ul style="list-style-type: none"> Encoder resolution Encoder type 	<ul style="list-style-type: none"> Encoder resolution: Setting of Pn00C = n.□□X□ (Encoder Resolution for Tests without a Motor) Encoder type: Setting of Pn00C = n.□X□□ (Encoder Type Selection for Tests without a Motor)

If you use fully-closed loop control, the external encoder information is also used.

External Encoder Connection Status	Information That Is Used	Source of Information
Connected	External encoder information	Information in the external encoder that is connected
Not connected	Resolution	Resolution: 256
	Encoder type	Encoder type: Incremental encoder

Linear Servomotors

Motor Connection Status	Information That Is Used	Source of Information
Connected	Motor information	Information in the motor that is connected
	Linear encoder information <ul style="list-style-type: none"> ■ Resolution ■ Encoder pitch ■ Encoder type 	Information in the linear encoder that is connected
Not connected	Motor information	Setting of Pn000 = n.X□□□ (Rotary/Linear Startup Selection When Encoder Is Not Connected)
	Linear encoder information <ul style="list-style-type: none"> ■ Resolution ■ Encoder pitch ■ Encoder type 	<ul style="list-style-type: none"> ■ Resolution: 256 ■ Encoder pitch: Setting of Pn282 (Linear Encoder Pitch) ■ Encoder type: Setting of Pn00C = n.□X□□ (Encoder Type Selection for Tests without a Motor)

Related Parameters

Parameter	Meaning	When Enabled	Classification
Pn000	n.0□□□ (default setting)	After restart	Setup
	n.1□□□		

Linear Encoder Pitch

	Setting Range	Setting Unit	Default Setting	When Enabled	Classification
Pn282	0 to 6,553,600	0.01 μm	0	After restart	Setup

(applies to Speed Control, Position Control and Force Control)

Parameter	Meaning	When Enabled	Classification
Pn00C	n.□□0□ (default setting)	After restart	Setup
	n.□□1□		
	n.□□2□		
	n.□□3□		

Convenient Function to Use during Trial Operation > Test without a Motor

Parameter		Meaning	When Enabled	Classification
	n.□0□□ (default setting)	Use an incremental encoder for tests without a motor.		
	n.□1□□	Use an absolute encoder for tests without a motor.		

Motor Position and Speed Responses

For a test without a motor, the following responses are simulated for references from the host controller according to the gain settings for position or speed control.

- Servomotor position
- Motor speed
- External encoder position

The load model will be for a rigid system with the moment of inertia ratio that is set in Pn103.

Restrictions

The following functions cannot be used during the test without a motor.

- Regeneration and dynamic brake operation
- Brake output signal
- Items marked with “x” in the following utility function table

SigmaWin+		Digital Operator		Executable?		Reference
Menu Dialog Box Button	SigmaWin+ Function Name	Fn No.	Utility Function Name	Motor Not Connected	Motor Connected	
Setup	Origin Search*1	Fn003	Origin Search	○	○	↪ Chap. 8.7.3 'Origin Search' ...page 272
	Absolute Encoder Reset	Fn008	Reset Absolute Encoder	×	○	↪ Chap. 6.16.5 'Operating Procedure' ...page 180
	Analog Monitor Output Adjustment	Fn00C	Adjust Analog Monitor Output Offset	○	○	↪ Chap. 10.4.4 'Using the Analog Monitors' ...page 418
		Fn00D	Adjust Analog Monitor Output Gain	○	○	↪ Chap. 10.4.4 'Using the Analog Monitors' ...page 418
	Motor Current Detection Offset Adjustment	Fn00E	Autotune Motor Current Detection Signal Offset	×	○	↪ Chap. 7.13.1 'Adjusting the Motor Current Detection Signal Offset' ...page 241
Fn00F		Manually Adjust Motor Current Detection Signal Offset	×	○		

Convenient Function to Use during Trial Operation > Test without a Motor

SigmaWin+		Digital Operator		Executable?		Reference
Menu Dialog Box Button	SigmaWin+ Function Name	Fn No.	Utility Function Name	Motor Not Connected	Motor Connected	
	Parameter Write Prohibition Setting	Fn010	Write Prohibition Setting	○	○	↪ Chap. 6.2.5 'Write Prohibition Setting for SERVOPACK Parameters' ...page 131
	Multiturn Limit Setting	Fn013	Multiturn Limit Setting after Multiturn Limit Disagreement Alarm	×	○	↪ Chap. 7.9.9 'Multiturn Limit Disagreement Alarm (A.CC0)' ...page 225
	Reset Configuration Error of Option Module	Fn014	Reset Option Module Configuration Error	○	○	↪ Chap. 16.4.7 'Resetting Alarms Detected in Option Modules' ...page 597
	Initializing the Vibration Detection Level	Fn01B	Initialize Vibration Detection Level	×	×	↪ Chap. 7.12.1 'Initializing the Vibration Detection Level' ...page 236
	Set Origin	Fn020	Set Absolute Linear Encoder Origin	×	○	↪ Chap. 6.17.1 'Setting the Origin of the Absolute Encoder' ...page 183
	Reset Motor Type Alarm	Fn021	Reset Motor Type Alarm	○	○	–
	Software Reset	Fn030	Software Reset	○	○	↪ Chap. 7.11.1 'Software Reset' ...page 233
	Polarity Detection	Fn080	Polarity Detection	×	×	↪ Chap. 6.10.1 'Polarity Detection' ...page 152
	Tuning-less Level Setting	Fn200	Tuning-less Level Setting	×	×	↪ Chap. 9.6.1 'Estimating the Moment of Inertia' ...page 295
	Easy FFT	Fn206	Easy FFT	×	×	↪ Chap. 9.15.2 'Easy FFT' ...page 403
Parameter	Initialize*2	Fn005	Initialize Parameters	○	○	↪ Chap. 6.2.6 'Initializing SERVOPACK Parameter Settings' ...page 136

Convenient Function to Use during Trial Operation > Test without a Motor

SigmaWin+		Digital Operator		Executable?		Reference
Menu Dialog Box Button	SigmaWin+ Function Name	Fn No.	Utility Function Name	Motor Not Connected	Motor Connected	
Tuning	Autotuning without Host Reference	Fn201	Advanced Autotuning without Reference	×	×	➔ Chap. 9.7.1 'Autotuning without Host Reference' ...page 306
	Autotuning with Host Reference	Fn202	Advanced Autotuning with Reference	×	×	➔ Chap. 9.8.1 'Autotuning with a Host Reference' ...page 322
	Custom Tuning	Fn203	One-Parameter Tuning	×	×	➔ Chap. 9.9.1 'Custom Tuning' ...page 332
	Adjust Anti-resonance Control	Fn204	Adjust Anti-resonance Control	×	×	➔ Chap. 9.10.1 'Anti-Resonance Control Adjustment' ...page 347
	Vibration Suppression	Fn205	Vibration Suppression	×	×	➔ Chap. 9.11.1 'Vibration Suppression' ...page 355
Monitoring	Product Information	Fn011	Display Servomotor Model	○	○	➔ Chap. 10.2.1 'Monitoring Product Information' ...page 410
		Fn012	Display Software Version	○	○	
		Fn01E	Display SERVOPACK and Servomotor IDs	○	○	➔ Chap. 10.2.1 'Monitoring Product Information' ...page 410
		Fn01F	Display Servomotor ID from Feedback Option Module	○	○	➔ Chap. 10.2.1 'Monitoring Product Information' ...page 410
Test Operation	Jogging	Fn002	Jogging	○	○	➔ Chap. 8.4.1 'Trial Operation for the Servomotor without a Load' ...page 255
	Program Jogging	Fn004	Program Jogging	○	○	➔ Chap. 8.7.2 'Program Jogging' ...page 264

Convenient Function to Use during Trial Operation > Test without a Motor

SigmaWin+		Digital Operator		Executable?		Reference
Menu Dialog Box Button	SigmaWin+ Function Name	Fn No.	Utility Function Name	Motor Not Connected	Motor Connected	
Alarms	Display Alarm	Fn000	Display Alarm History	<input type="radio"/>	<input type="radio"/>	↪ Chap. 16.4.5 'Displaying the Alarm History' ...page 594
		Fn006	Clear Alarm History	<input type="radio"/>	<input type="radio"/>	↪ Chap. 16.4.6 'Clearing the Alarm History' ...page 596

- *1. Cannot be used when connecting a Linear Servomotor.
- *2. An **Initialize** Button is displayed in the Parameter Editing Dialog Box.

9 Tuning

9.1 Overview

This chapter provides information on the flow of tuning, details on tuning functions, and related operating procedures.

9.2 Overview and Flow of Tuning

9.2.1 Overview

Tuning is performed to optimize response by adjusting the servo gains in the SERVO-PACK.

The servo gains are set using a combination of parameters, such as parameters for the speed loop gain, position loop gain, filters, friction compensation, and moment of inertia ratio. These parameters influence each other, so you must consider the balance between them.

The servo gains are set to stable settings by default. Use the various tuning functions to increase the response even further for the conditions of your machine.

The basic tuning procedure is shown in the following flowchart. Make suitable adjustments considering the conditions and operating requirements of your machine.

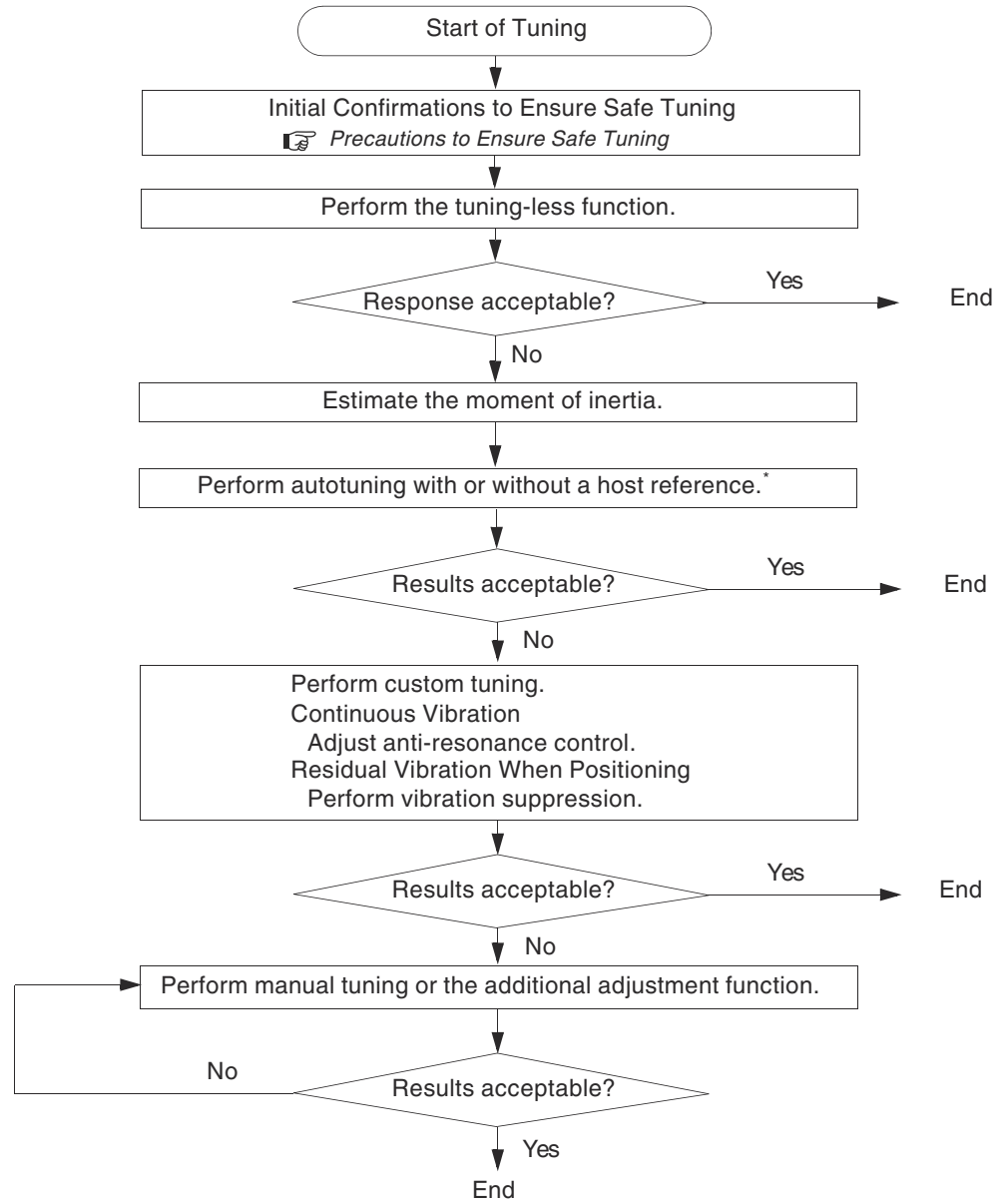


Fig. 218: Overview and Flow of Tuning

* If possible, perform autotuning with a host reference.
If a host controller is not available, set an operation pattern that is as close as possible to the host reference and perform autotuning without a host reference.
If an operation pattern that is close to the host reference is not possible, perform autotuning with a host reference while performing program jogging.

9.2.2 Tuning Functions

The following table provides an overview of the tuning functions.

Tuning Function	Outline	Applicable Control Methods	Reference
Tuning-less Function	This automatic adjustment function is designed to enable stable operation without servo tuning. This function can be used to obtain a stable response regardless of the type of machine or changes in the load. You can use it with the default settings.	Speed control or position control	↪ Chap. 9.5.1 'Tuning-less Function' ...page 290
Moment of Inertia Estimation	The moment of inertia ratio is calculated by operating the Servomotor a few times. The moment of inertia ratio that is calculated here is used in other tuning functions.	Speed control, position control, or torque control	↪ Chap. 9.6.1 'Estimating the Moment of Inertia' ...page 295
Autotuning without Host Reference	The following parameters are automatically adjusted in the internal references in the SERVOPACK during automatic operation. <ul style="list-style-type: none"> ■ Gains (e.g., position loop gain and speed loop gain) ■ Filters (torque reference filter and notch filters) ■ Friction compensation ■ Anti-resonance control ■ Vibration suppression 	Speed control or position control	↪ Chap. 9.7.1 'Autotuning without Host Reference' ...page 306
Autotuning with Host Reference	The following parameters are automatically adjusted with the position reference input from the host controller while the machine is in operation. You can use this function for fine-tuning after you perform autotuning without a host reference. <ul style="list-style-type: none"> ■ Gains (e.g., position loop gain and speed loop gain) ■ Filters (torque reference filter and notch filters) ■ Friction compensation ■ Anti-resonance control ■ Vibration suppression 	Position control	↪ Chap. 9.8.1 'Autotuning with a Host Reference' ...page 322
Custom Tuning	The following parameters are adjusted with the position reference or speed reference input from the host controller while the machine is in operation. <ul style="list-style-type: none"> ■ Gains (e.g., position loop gain and speed loop gain) ■ Filters (torque reference filter and notch filters) ■ Friction compensation ■ Anti-resonance control 	Speed control or position control	↪ Chap. 9.9.1 'Custom Tuning' ...page 332

Tuning Function	Outline	Applicable Control Methods	Reference
Anti-resonance Control Adjustment	This function effectively suppresses continuous vibration.	Speed control or position control	↪ Chap. 9.10.1 'Anti-Resonance Control Adjustment' ...page 347
Vibration Suppression	This function effectively suppresses residual vibration if it occurs when positioning.	Position control	↪ Chap. 9.11.1 'Vibration Suppression' ...page 355
Speed Ripple Compensation	This function reduces the ripple in the motor speed.	Speed control, position control, or torque control	↪ Chap. 9.12.1 'Speed Ripple Compensation' ...page 361
Additional Adjustment Function	This function combines auto-tuning with custom tuning. You can use it to improve adjustment results.	Depends on the functions that you use.	↪ Chap. 9.13.1 'Additional Adjustment Functions' ...page 369
Manual Tuning	You can manually adjust the servo gains to adjust the response.	Speed control, position control, or torque control	↪ Chap. 9.14.1 'Manual Tuning' ...page 384

9.2.3 Diagnostic Tool

You can use the following tools to measure the frequency characteristics of the machine and set notch filters.

Diagnostic Tool	Outline	Applicable Control Methods	Reference
Mechanical Analysis	The machine is subjected to vibration to detect resonance frequencies. The measurement results are displayed as waveforms or numeric data.	Speed control, position control, or torque control	↪ Chap. 9.15.1 'Mechanical Analysis' ...page 402
Mechanical Analysis	The machine is subjected to vibration to detect resonance frequencies. The measurement results are displayed only as numeric data.	Speed control, position control, or torque control	↪ Chap. 9.15.2 'Easy FFT' ...page 403

9.3 Monitoring Methods

You can use the data tracing function of the SigmaWin+ or the analog monitor signals of the SERVOPACK for monitoring. If you perform custom tuning or manual tuning, always use the above functions to monitor the machine operating status and SERVOPACK signal waveform while you adjust the servo gains.

Check the adjustment results with the following response waveforms.

Precautions to Ensure Safe Tuning > Overtravel Settings

Position Control

Item	Unit	
	Rotary Servomotor	Linear Servomotor
Torque reference	%	
Feedback speed	min ⁻¹	mm/s
Position reference speed	min ⁻¹	mm/s
Position deviation	Reference units	

Speed Control

Item	Unit	
	Rotary Servomotor	Linear Servomotor
Torque reference	%	
Feedback speed	min ⁻¹	mm/s
Reference speed	min ⁻¹	mm/s

Torque Control

Item	Unit	
	Rotary Servomotor	Linear Servomotor
Torque reference	%	
Feedback speed	min ⁻¹	mm/s

9.4 Precautions to Ensure Safe Tuning

9.4.1 Overview



CAUTION

Observe the following precautions when you perform tuning.

- Do not touch the rotating parts of the motor when the servo is ON.
- Before starting the Servomotor, make sure that an emergency stop can be performed at any time.
- Make sure that trial operation has been successfully performed without any problems.
- Provide an appropriate stopping device on the machine to ensure safety.

Perform the following settings in a way that is suitable for tuning.

9.4.2 Overtravel Settings

Overtravel settings are made to force the Servomotor to stop for a signal input from a limit switch when a moving part of the machine exceeds the safe movement range.

Refer to the following section for details.

➔ [Chap. 6.11.1 'Overtravel and Related Settings' ...page 155](#)

9.4.3 Torque Limit Settings

You can limit the torque that is output by the Servomotor based on calculations of the torque required for machine operation. You can use torque limits to reduce the amount of shock applied to the machine when problems occur, such as collisions or interference. If the torque limit is lower than the torque that is required for operation, overshooting or vibration may occur. Refer to the following section for details.

→ [Chap. 7.8.1 'Selecting Torque Limits' ...page 212](#)

9.4.4 Setting the Position Deviation Overflow Alarm Level

The position deviation overflow alarm is a protective function that is enabled when the SERVOPACK is used in position control.

If the alarm level is set to a suitable value, the SERVOPACK will detect excessive position deviation and will stop the Servomotor if the Servomotor operation does not agree with the reference.

The position deviation is the difference between the position reference value and the actual position.

You can calculate the position deviation from the position loop gain (Pn102) and the motor speed with the following formula.

Rotary Servomotors

$$\text{Position deviation [reference units]} = \frac{\text{Motor speed [min}^{-1}\text{]}}{60} \times \frac{\text{Encoder resolution}}{\text{Pn102 [0.1/s]/10}^{*2, *3}} \times \frac{\text{Denominator}^{*1}}{\text{Numerator}}$$

Fig. 219: Position Deviation - Formula - Rotary Servomotors

Linear Servomotors

$$\text{Position deviation [reference units]} = \frac{\text{Motor speed [mm/s]}}{\text{Pn102 [0.1/s]/10}^{*2, *3}} \times \frac{\text{Resolution}}{\text{Linear encoder pitch [\mu m]/1,000}} \times \frac{\text{Denominator}}{\text{Numerator}}$$

Fig. 220: Position Deviation - Formula - Linear Servomotors

Position Deviation Overflow Alarm Level (Pn520) [setting unit: reference units]

Rotary Servomotors

$$\text{Pn520} > \frac{\text{Maximum motor speed [min}^{-1}\text{]}}{60} \times \frac{\text{Encoder resolution}}{\text{Pn102 [0.1/s]/10}^{*2, *3}} \times \frac{\text{Denominator}^{*1}}{\text{Numerator}} \times \underline{\underline{(1.2 \text{ to } 2)^{*4}}}$$

Fig. 221: Position Deviation Overflow Alarm Level - Formula - Rotary Servomotors

Linear Servomotors

$$\text{Pn520} > \frac{\text{Maximum motor speed [mm/s]}}{\text{Pn102 [0.1/s]/10}^{*2, *3}} \times \frac{\text{Resolution}}{\text{Linear encoder pitch [\mu m]/1,000}} \times \frac{\text{Denominator}^{*1}}{\text{Numerator}} \times \underline{\underline{(1.2 \text{ to } 2)^{*4}}}$$

Fig. 222: Position Deviation Overflow Alarm Level - Formula - Linear Servomotors

*1. Refer to the following section for details.

→ [Chap. 6.15.1 'Setting Unit Systems' ...page 171](#)

*2. When model following control (Pn140 = n.□□□1) is enabled, use the setting of Pn141 (Model Following Control Gain) instead of the setting of Pn102 (Position Loop Gain).

*3. To check the setting of Pn102 on the Digital Operator, change the parameter display setting to display all parameters (Pn00B = n.□□□1).

*4. The underlined coefficient "× (1.2 to 2)" adds a margin to prevent an A.d00 alarm (Position Deviation Overflow) from occurring too frequently.

If you set a value that satisfies the formula, an A.d00 alarm (Position Deviation Overflow) should not occur during normal operation.

If the Servomotor operation does not agree with the reference, position deviation will occur, an error will be detected, and the Servomotor will stop.

The following calculation example uses a Rotary Servomotor with a maximum motor speed of 6,000 and an encoder resolution of 16,777,216 (24 bits). Pn102 is set to 400.

$$\frac{\text{Denominator}}{\text{Numerator}} = \frac{1}{16}$$

Fig. 223: Position Deviation Overflow Alarm Level - Rotary Servomotors - Calculation Example - Formula 1

$$\begin{aligned} \text{Pn520} &= \frac{6,000}{60} \times \frac{16,777,216}{400/10} \times \frac{1}{16} \times 2 \\ &= 2,621,440 \times 2 \\ &= 5,242,880 \text{ (default setting of Pn520)} \end{aligned}$$

Fig. 224: Position Deviation Overflow Alarm Level - Rotary Servomotors - Calculation Example - Formula 2

If the acceleration/deceleration rate required for the position reference exceeds the tracking capacity of the Servomotor, the tracking delay will increase and the position deviation will no longer satisfy the above formulas. If this occurs, lower the acceleration/deceleration rate so that the Servomotor can follow the position reference or increase the position deviation overflow alarm level.

Related Parameters

Position Deviation Overflow Alarm Level

	Setting Range	Setting Unit	Default Setting	When Enabled	Classification
Pn520	1 to 1,073,741,823	1 reference unit	5,242,880	Immediately	Setup

(applies to Position Control)

Position Deviation Overflow Warning Level

	Setting Range	Setting Unit	Default Setting	When Enabled	Classification
Pn51E	10 to 100	1%	100	Immediately	Setup

(applies to Position Control)

Related Alarms

Alarm Number	Alarm Name	Alarm Meaning
A.d00	Position Deviation Overflow	This alarm occurs if the position deviation exceeds the setting of Pn520 (Position Deviation Overflow Alarm Level).

Related Warnings

Warning Number	Warning Name	Warning Meaning
A.900	Position Deviation Overflow	This warning occurs if the position deviation exceeds the specified percentage (Pn520 × Pn51E/100).

9.4.5 Vibration Detection Level Setting

You can set the vibration detection level (Pn312) to more accurately detect A.520 alarms (Vibration Alarm) and A.911 warnings (Vibration Warning) when vibration is detected during machine operation.

Set the initial vibration detection level to an appropriate value. Refer to the following section for details.

→ [Chap. 7.12.1 'Initializing the Vibration Detection Level' ...page 236](#)

9.4.6 Setting the Position Deviation Overflow Alarm Level at Servo ON

If the servo is turned ON when there is a large position deviation, the Servomotor will attempt to return to the original position to bring the position deviation to 0, which may create a hazardous situation. To prevent this, you can set a position deviation overflow alarm level at servo ON to restrict operation.

The related parameters and alarms are given in the following tables.

Related Parameters

Position Deviation Overflow Alarm Level at Servo ON

	Setting Range	Setting Unit	Default Setting	When Enabled	Classification
Pn526	1 to 1,073,741,823	1 reference unit	5,242,880	Immediately	Setup

(applies to Position Control)

Position Deviation Overflow Warning Level at Servo ON

	Setting Range	Setting Unit	Default Setting	When Enabled	Classification
Pn528	10 to 100	1%	100	Immediately	Setup

(applies to Position Control)

Rotary Servomotors

Speed Limit Level at Servo ON

	Setting Range	Setting Unit	Default Setting	When Enabled	Classification
Pn529	0 to 10,000	1 min ⁻¹	10,000	Immediately	Setup

(applies to Position Control)

Linear Servomotors

Speed Limit Level at Servo ON

	Setting Range	Setting Unit	Default Setting	When Enabled	Classification
Pn584	0 to 10,000	1 mm/s	10,000	Immediately	Setup

(applies to Position Control)

Related Alarms

Alarm Number	Alarm Name	Alarm Meaning
A.d01	Position Deviation Overflow Alarm at Servo ON	This alarm occurs if Servo ON command (Enable Operation command) is executed after the position deviation exceeded the setting of Pn526 (Position Deviation Overflow Alarm Level at Servo ON) while the servo was OFF.
A.d02	Position Deviation Overflow Alarm for Speed Limit at Servo ON	If position deviation remains in the deviation counter, the setting of Pn529 or Pn584 (Speed Limit Level at Servo ON) will limit the speed when the servo is turned ON. This alarm occurs if a position reference is input and the setting of Pn520 (Position Deviation Overflow Alarm Level) is exceeded.

Refer to the following section for information on troubleshooting alarms.

→ [Chap. 16.4.4 'Resetting Alarms' ...page 594](#)

Related Warnings

Warning Number	Warning Name	Warning Meaning
A.901	Position Deviation Overflow Warning at Servo ON	This warning occurs if the servo is turned ON while the position deviation exceeds the specified percentage ($Pn526 \times Pn528/100$).

9.5 Tuning-less Function

9.5.1 Overview

The tuning-less function performs autotuning to obtain a stable response regardless of the type of machine or changes in the load. Autotuning is started when the servo is turned ON.



CAUTION

- The tuning-less function is disabled during torque control.
- The Servomotor may momentarily emit a sound the first time the servo is turned ON after the Servomotor is connected to the machine. This sound is caused by setting the automatic notch filter. It does not indicate a problem. The sound will not be emitted from the next time the servo is turned ON.
- The Servomotor may vibrate if it exceeds the allowable load moment of inertia. If that occurs, set the tuning-less load level to 2 ($Pn170 = n.2□□□$) or reduce the Tuningless Rigidity Level ($Pn170 = n.□X□□$).
- To ensure safety, make sure that you can perform an emergency stop at any time when you execute the tuning-less function.

9.5.2 Application Restrictions

The following application restrictions apply to the tuning-less function.

Function	Executable*	Remarks
Vibration Detection Level Initialization	✓	–

Function	Executable*	Remarks
Moment of Inertia Estimation	×	Disable the tuning-less function (Pn170 = n.□□□0) before you execute moment of inertia estimation.
Autotuning without Host Reference	×	Disable the tuning-less function (Pn170 = n.□□□0) before you execute autotuning without a host reference.
Autotuning with Host Reference	×	–
Custom Tuning	×	–
Anti-Resonance Control Adjustment	×	–
Vibration Suppression	×	–
Easy FFT	✓	The tuning-less function is disabled while you execute Easy FFT and then it is enabled when Easy FFT has been completed.
Friction Compensation	×	–
Gain Selection	×	–
Mechanical Analysis	✓	The tuning-less function is disabled while you execute mechanical analysis and then it is enabled when mechanical analysis has been completed.

* ✓: Yes ×: No

9.5.3 Operating Procedure

The tuning-less function is enabled in the default settings. No specific procedure is required. You can use the following parameter to enable or disable the tuning-less function.

Parameter	Meaning	When Enabled	Classification
Pn170	n.□□□0	Disable tuning-less function.	After restart Setup
	n.□□□1 (default setting)	Enable tuning-less function.	
	n.□□0□ (default setting)	Use for speed control.	
	n.□□1□	Use for speed control and use host controller for position control.	

When you enable the tuning-less function, you can select the tuning-less type. Normally, set Pn14F to n.□□2□ (Use tuning-less type 3) (default setting). If compatibility with previous models is required, set Pn14F to n.□□0□ (Use tuning-less type 1) or n.□□1□ (Use tuning-less type 2).

Parameter		Meaning	When Enabled	Classification
Pn14F	n.□□0□	Use tuning-less type 1.	After restart	Tuning
	n.□□1□	Use tuning-less type 2. (The noise level is improved more than with tuning-less type 1.)		
	n.□□2 □ (default setting)	Use tuning-less type 3.		

Tuning-less Level Settings

If vibration or other problems occur, change the tuning-less levels. To change the tuning-less levels, use the SigmaWin+.

Preparations

Check the following settings before you set the tuning-less levels.

- The tuning-less function must be enabled (Pn170 = n.□□□1).
- The test without a motor function must be disabled (Pn00C = n.□□□0).

Procedure

Use the following procedure to set the tuning-less levels.

In addition to the following procedure, you can also set the parameters directly. Refer to [→ 'Related Parameters' ...page 292](#) for the parameters to set.

1. Click the Servo Drive Button in the workspace of the Main Window of the SigmaWin+.
2. Select **Response Level Setting** in the Menu Dialog Box.
 - ➔ The Tuning-less Level Setting-Adj Dialog Box will be displayed.
3. Click the or Button to adjust the tuning-less level setting. Increase the tuning-less level setting to increase the response. Decrease the tuning-less level setting to suppress vibration.

The default response level setting is 4.

Tuning-less Level	Description	Remarks
7	Response level: High	You cannot select these levels if tuning-less type 1 or 2 (Pn14F = n.□□0□ or n.□□1□) is used.
6		
5		
4 (default setting)		-
3		
2		
1		
0	Response level: Low	

4. Click the Completed Button.
 - ➔ The adjustment results will be saved in the SERVOPACK.

Related Parameters

Tuning-less Rigidity Level

If you use tuning-less type 1 or 2 (Pn14F = n.□□0□ or n.□□1□), set the tuning-less level to between 0 and 4 (Pn170 = n.□0□□ to n.□4□□). Do not set the tuning-less level to between 5 and 7 (Pn170 = n.□5□□ to n.□7□□).

Parameter		Meaning	When Enabled	Classification
Pn170	n.□0□□	Tuning-less rigidity level 0 (low rigidity)	Immediately	Setup
	n.□1□□	Tuning-less rigidity level 1		
	n.□2□□	Tuning-less rigidity level 2		
	n.□3□□	Tuning-less rigidity level 3		
	n.□4□□ (default setting)	Tuning-less rigidity level 4		
	n.□5□□	Tuning-less rigidity level 5		
	n.□6□□	Tuning-less rigidity level 6		
	n.□7□□	Tuning-less rigidity level 7 (high rigidity)		

Tuning-less Load Level

Parameter		Meaning	When Enabled	Classification
Pn170	n.0□□□	Tuning-less load level 0	Immediately	Setup
	n.1□□□ (default setting)	Tuning-less load level 1		
	n.2□□□	Tuning-less load level 2		

9.5.4 Troubleshooting Alarms

An A.521 alarm (Autotuning Alarm) will occur if a resonant sound occurs or if excessive vibration occurs during position control. If an alarm occurs, implement the following measures.

- Resonant Sound
Decrease the setting of Pn170 = n.X□□□ or the setting of Pn170 = n.□X□□.
- Excessive Vibration during Position Control
Increase the setting of Pn170 = n.X□□□ or decrease the setting of Pn170 = n.□X□□.

9.5.5 Parameters Disabled by Tuning-less Function

When the tuning-less function is enabled (Pn170 = n.□□□1) (default setting), the parameters in the following table are disabled.

Item	Parameter Name	Parameter Number
Gain-Related Parameters	Speed Loop Gain	Pn100
	Second Speed Loop Gain	Pn104

Item	Parameter Name	Parameter Number
	Speed Loop Integral Time Constant	Pn101
	Second Speed Loop Integral Time Constant	Pn105
	Position Loop Gain	Pn102
	Second Position Loop Gain	Pn106
	Moment of Inertia Ratio	Pn103
Advanced Control-Related Parameters	Friction Compensation Function Selection	Pn408 = n.X□□□
	Anti-Resonance Control Selection	Pn160 = n.□□□X
Gain Selection-Related Parameters	Gain Switching Selection	Pn139 = n.□□□X

The tuning-less function is disabled during torque control, Easy FFT, and mechanical analysis for a vertical axis. The gain-related parameters in the above table are enabled for torque control, Easy FFT, and mechanical analysis. Of these, Pn100, Pn103, and Pn104 are enabled for torque control.

9.5.6 Automatically Adjusted Function Setting

You can also automatically adjust notch filters.

Normally, set Pn460 to n.□1□□ (Adjust automatically) (default setting). Vibration is automatically detected and a notch filter is set.

Set Pn460 to n.□0□□ (Do not adjust automatically) only if you do not change the setting of the notch filter before you execute the tuning-less function.

Parameter	Meaning	When Enabled	Classification
Pn460	n.□0□□	Immediately	Tuning
	n.□1□□ (default setting)		

9.5.7 Related Parameters

The following parameters are automatically adjusted when you execute the tuning-less function.

Do not manually change the settings of these parameters after you have enabled the tuningless function.

Parameter	Name
Pn401	First Stage First Torque Reference Filter Time Constant
Pn40C	Second Stage Notch Filter Frequency
Pn40D	Second Stage Notch Filter Q Value

9.6 Estimating the Moment of Inertia

9.6.1 Overview

This section describes how the moment of inertia is calculated.

The moment of inertia ratio that is calculated here is used in other tuning functions. You can also estimate the moment of inertia during autotuning without a host reference. Refer to the following section for the procedure.

→ [Chap. 9.7.5 'Operating Procedure' ...page 309](#)

9.6.2 Outline

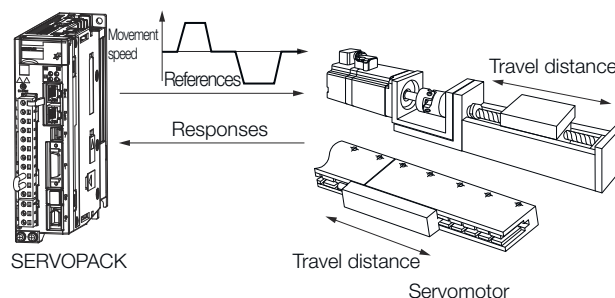
The moment of inertia during operation is automatically calculated by the SERVOPACK for round-trip (forward and reverse) operation. A reference from the host controller is not used.

The moment of inertia ratio (i.e., the ratio of the load moment of inertia to the motor moment of inertia) is a basic parameter for adjusting gains. It must be set as accurately as possible.

Although the load moment of inertia can be calculated from the weight and structure of the mechanisms, doing so is very troublesome and calculating it accurately can be very difficult with the complex mechanical structures that are used these days. With moment of inertia estimation, you can get an accurate load moment of inertia simply by operating the Servomotor in the actual system in forward and reverse a few times.

The Servomotor is operated with the following specifications.

- Maximum speed: $\pm 1,000 \text{ min}^{-1}$ (can be changed)
- Acceleration rate: $\pm 20,000 \text{ min}^{-1}/\text{s}$ (can be changed)
- Travel distance: ± 2.5 rotations max. (can be changed)



Note: Execute moment of inertia estimation after jogging to a position that ensures a suitable range of motion.

Fig. 225: Moment of Inertia Estimation

9.6.3 Restrictions

The following restrictions apply to estimating the moment of inertia.

Systems for which Execution Cannot Be Performed

- When the machine system can move only in one direction
- When the range of motion is 0.5 rotations or less

Systems for Which Adjustments Cannot Be Made Accurately

- When a suitable range of motion is not possible
- When the moment of inertia changes within the set operating range
- When the machine has high dynamic friction
- When the rigidity of the machine is low and vibration occurs when positioning is performed
- When the position integration function is used
- When proportional control is used

Preparations

Check the following settings before you execute moment of inertia estimation.

- The main circuit power supply must be ON.
- There must be no overtravel.
- The servo must be OFF.
- The control method must not be set to torque control.
- The gain selection switch must be set to manual gain selection (Pn139 = n.□□□0).
- The first gains must be selected.
- The test without a motor function must be disabled (Pn00C = n.□□□0).
- There must be no alarms or warnings.
- There must be no hard wire base block (HWBB).
- The parameters must not be write prohibited.
- The tuning-less function must be disabled (Pn170 = n.□□□0).


9.6.4 Applicable Tools

The following table lists the tools that you can use to estimate the moment of inertia and the applicable tool functions.

Tool	Function	Operating Procedure Reference
Digital Operator	You cannot estimate the moment of inertia from the Digital Operator.	
SigmaWin+	Tuning - Tuning	↪ Chap. 9.6.5 'Operating Procedure' ...page 296

9.6.5 Operating Procedure

Use the following procedure to set the moment of inertia ratio.

 **WARNING**

Estimating the moment of inertia requires operating the Servomotor and therefore presents hazards. Observe the following precaution.


- Confirm safety around moving parts.

This function involves automatic operation with vibration. Make sure that you can perform an emergency stop (to turn OFF the power supply) at any time. There will be movement in both directions within the set range of movement. Check the range of movement and the directions and implement protective controls for safety, such as the overtravel functions.

**CAUTION**

Be aware of the following points if you cancel the moment of inertia estimation while the Servomotor is operating.

- If you cancel operation with the **Servo OFF** Button, the Servomotor will stop according to setting of the Servo OFF stopping method (Pn001 = n.□□□X).
- If you cancel operation with the **Cancel** Button, the Servomotor will decelerate to a stop and then enter a zero-clamped state.

1. Click the  Servo Drive Button in the workspace of the Main Window of the SigmaWin+.
2. Select **Tuning** in the Menu Dialog Box.
 - ➔ The Tuning Dialog Box will be displayed. Click the **Cancel** Button to cancel tuning.
3. Click the Execute Button.
 - ➔

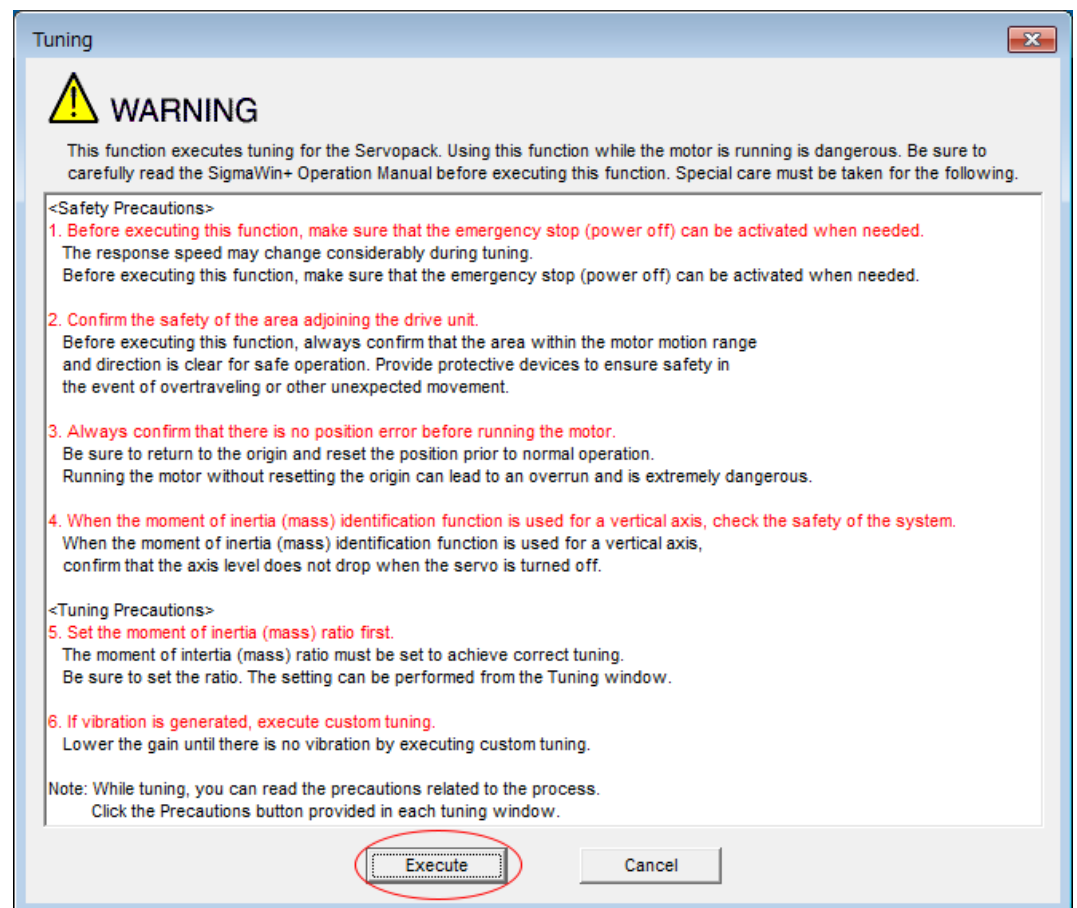


Fig. 226: Tuning - Warning

Estimating the Moment of Inertia > Operating Procedure

4. Click the Execute Button.

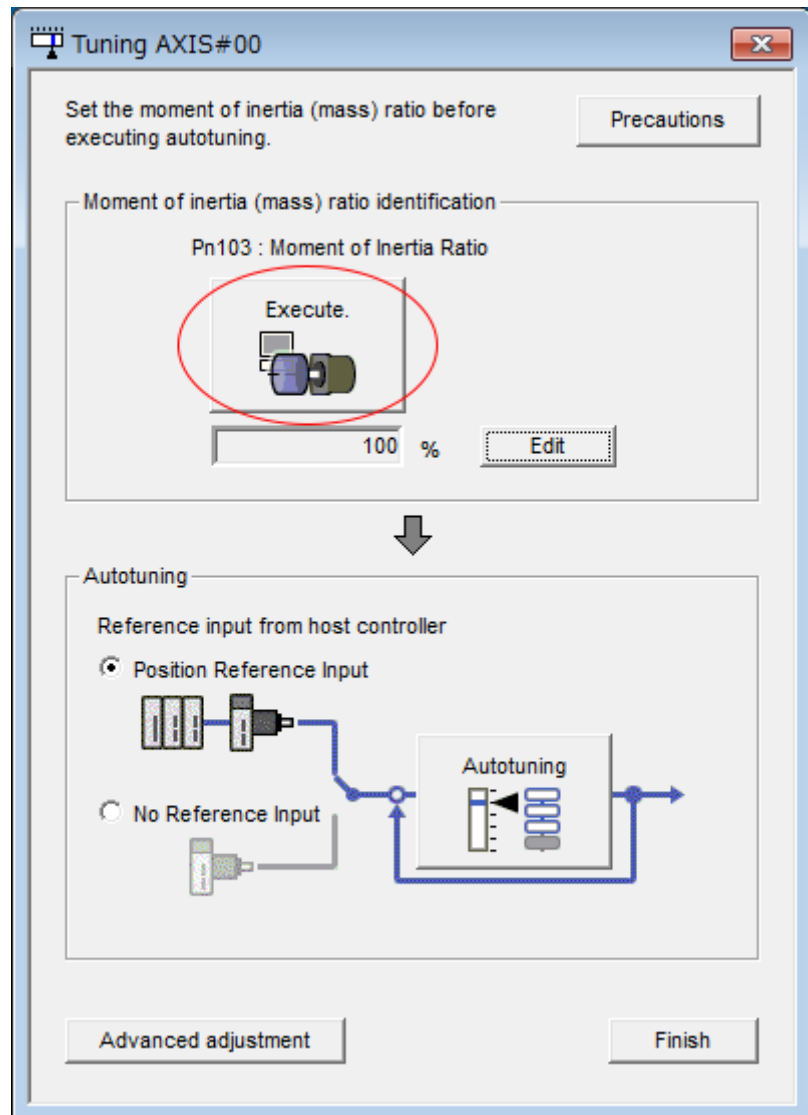


Fig. 227: Tuning - Execute Moment of Inertia Ratio Identification

5. Set the conditions as required.

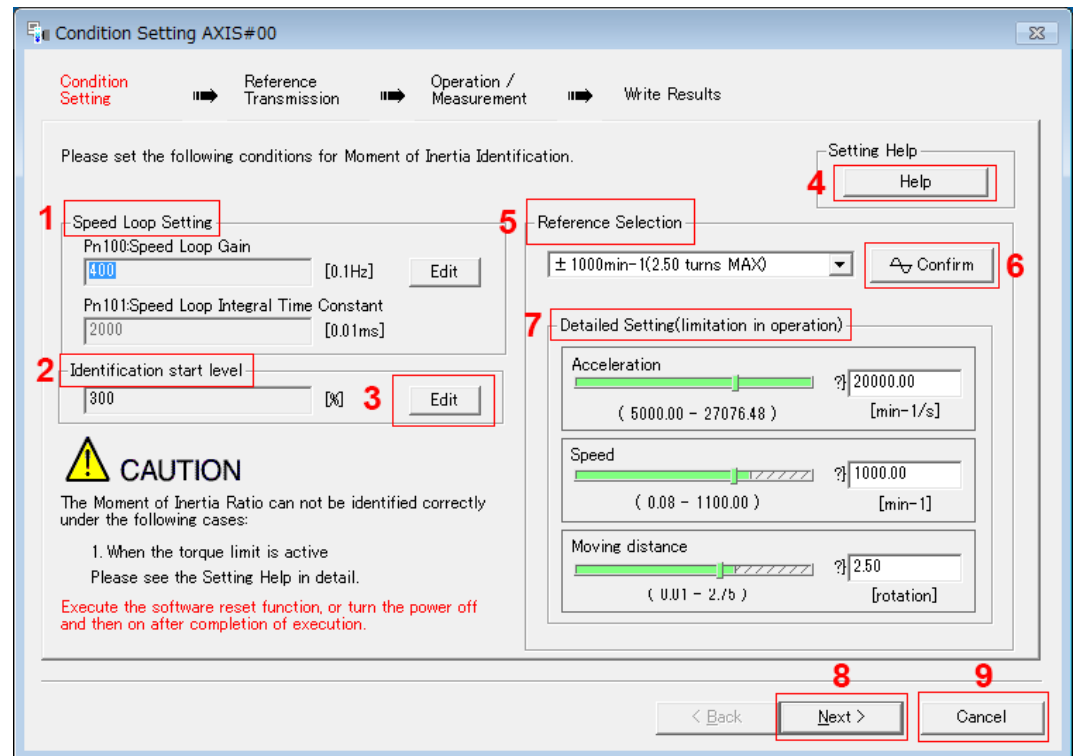


Fig. 228: Tuning - Condition Setting AXIS#00

➔ 1 - Speed Loop Setting Area

Make the speed loop settings in this area.

If the speed loop response is too bad, it will not be possible to measure the moment of inertia ratio accurately.

The values for the speed loop response that are required for moment of inertia estimation are set for the default settings. It is normally not necessary to change these settings.

If the default speed loop gain is too high for the machine (i.e., if vibration occurs), lower the setting. It is not necessary to increase the setting any farther.

2 - Identification Start Level Group

This is the setting of the moment of inertia calculation starting level.

If the load is large or the machine has low rigidity, the torque limit may be applied, causing moment of inertia estimation to fail.

If that occurs, estimation may be possible if you double the setting of the start level.

3 - Edit Buttons

Click the button to display a dialog box to change the settings related to the speed loop or estimation start level.

4 - Help Button

Click this button to display guidelines for setting the reference conditions. Make the following settings as required.

- Operate the Servomotor to measure the load moment of inertia of the machine in comparison with the rotor moment of inertia.
- Set the operation mode, reference pattern (maximum acceleration rate, maximum speed, and maximum travel distance), and speed loop-related parameters.
- Correct measurement of the moment of inertia ratio may not be possible depending on the settings. Set suitable settings using the measurement results as reference.

5 - Reference Selection Area

Either select the reference pattern for estimation processing from the box, or set the values in the **Detailed Setting** Group. Generally speaking, the larger the maximum acceleration rate is, the more accurate the moment of inertia estimation will be.

Set the maximum acceleration range within the possible range of movement considering the gear ratio, e.g., the pulley diameters or ball screw pitch.

6 - Confirm Button

Click this button to display the Reference Confirmation Dialog Box.

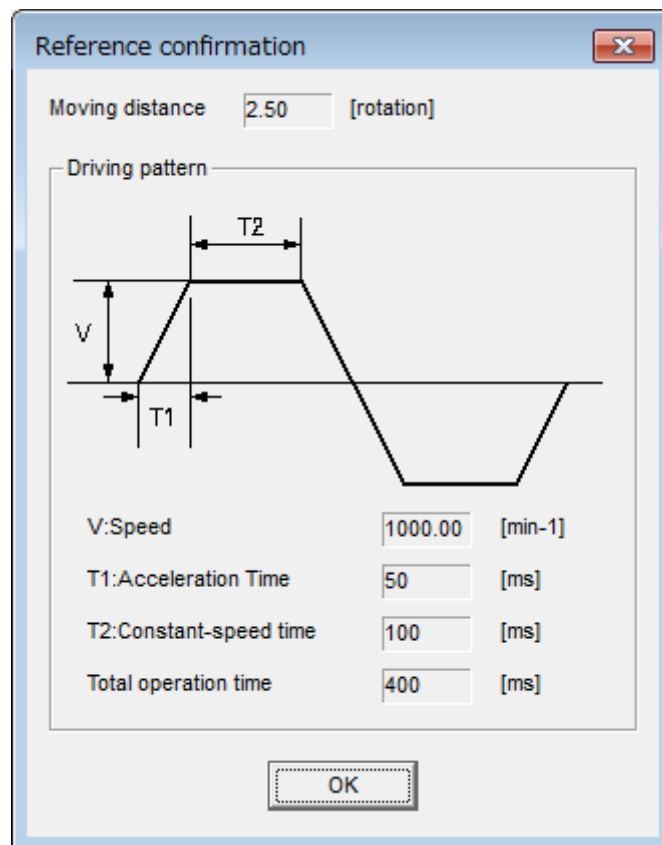


Fig. 229: Tuning - Reference Transmission Dialog Box, 1, en_GB Tuning - Reference Confirmation Dialog Box

7 - Detailed Setting Area

You can change the settings by moving the bars or directly inputting the settings to create the required reference pattern.

8 - Next Button

Click this button to display the Reference Transmission Dialog Box.

9 - Cancel Button

Click this button to return to the Tuning Dialog Box.

**CAUTION**

- The travel distance is the distance for one operation in the forward or reverse direction. During multiple operations, the operation starting position may move in one direction or the other. Confirm the possible operating range for each measurement or operation.
- Depending on the parameter settings and the moment of inertia of the machine, overshooting and undershooting may occur and may cause the maximum speed setting to be exceeded temporarily. Allow sufficient leeway in the settings.

**When Measurement Is Not Correct**

Estimating the moment of inertia ratio cannot be performed correctly if the torque limit is activated. Adjust the limits or reduce the acceleration rate in the reference selection so that the torque limit is not activated.

6. Click the **Next** Button.

➔ The Reference Transmission Dialog Box will be displayed.

7. Click the **Start** Button.

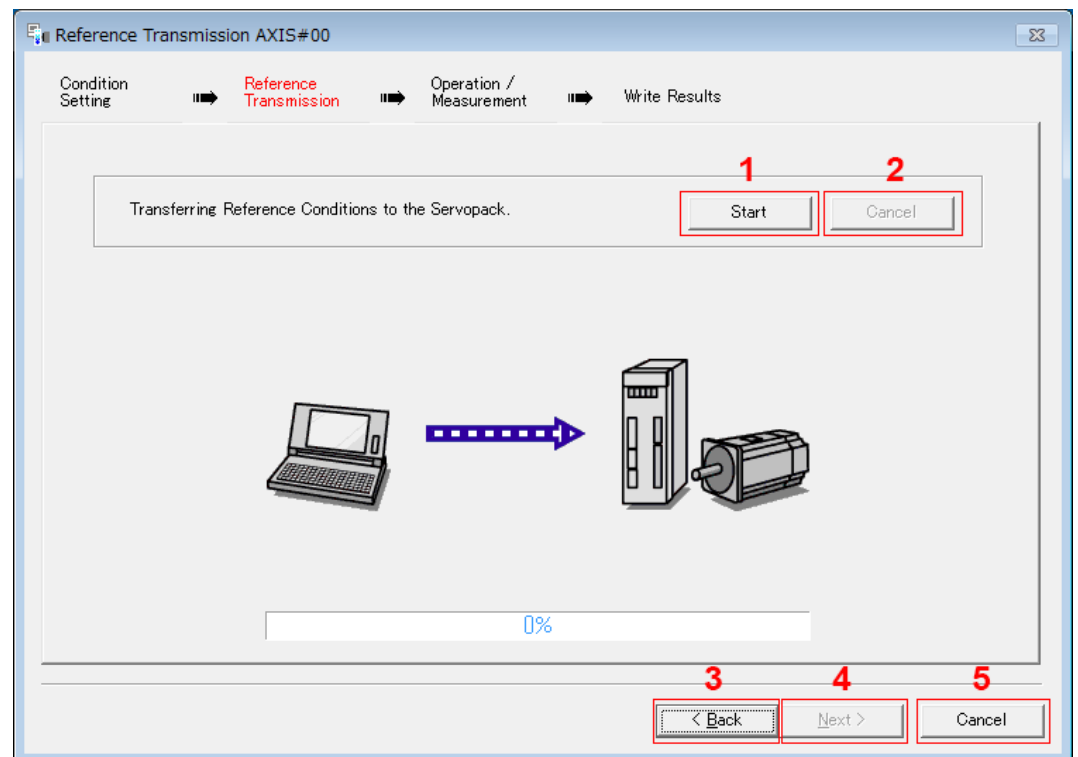


Fig. 230: Tuning - Reference Transmission Dialog Box

➔ **1 - Start** Button

The reference conditions will be transferred to the SERVOPACK. A progress bar will show the progress of the transfer.

2 - Cancel Button

The **Cancel** Button is enabled only while data is being transferred to the SERVOPACK.

You cannot use it after the transfer has been completed.

3 - Back Button

This button returns you to the Condition Setting Dialog Box. It is disabled while data is being transferred.

4 - Next Button

This button is enabled only when the data has been transferred correctly. You cannot use it if an error occurs or if you cancel the transfer before it is completed.

Click the **Next** Button to display the Operation/Measurement Dialog Box.

5 - Cancel Button

This button cancels processing and returns you to the Tuning Dialog Box.

8. Click the **Next** Button.
 - ➔ The Operation/Measurement Dialog Box will be displayed.
9. Click the **Servo On** Button.
 - ➔

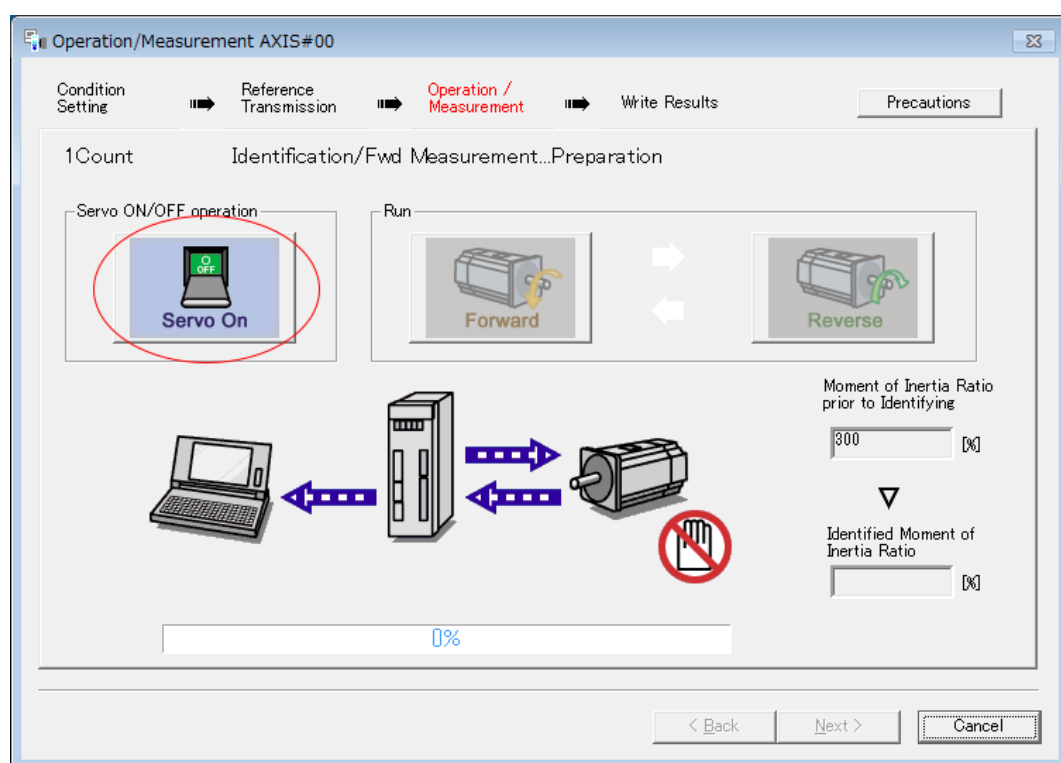


Fig. 231: Tuning - Operation/Measurement Dialog Box

10. Click the **Forward** Button.

The Servomotor shaft will rotate in the forward direction and the measurement will start. After the measurement and data transfer have been completed, the **Reverse** Button will be displayed in color.

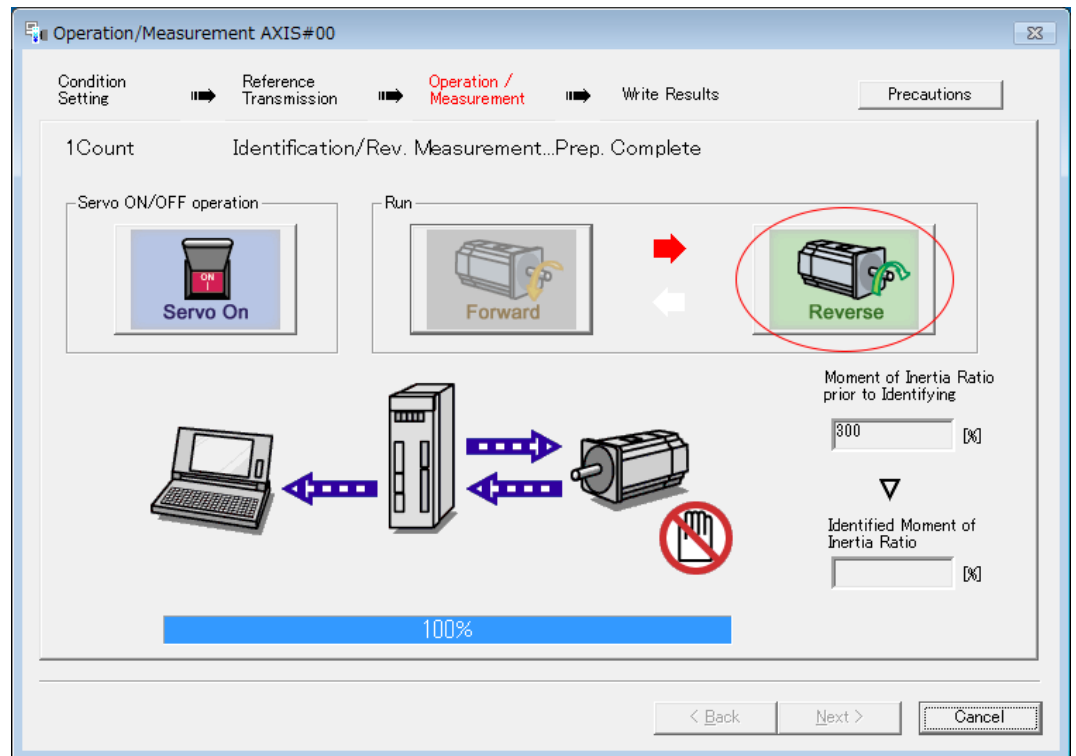
11. Click the **Reverse** Button.

Fig. 232: Tuning - Operation/Measurement Dialog Box - Reverse Button

- ➔ The Servomotor shaft will rotate in the reverse direction and the measurement will start. After the measurement and data transfer have been completed, the **Forward** Button will be displayed in color.

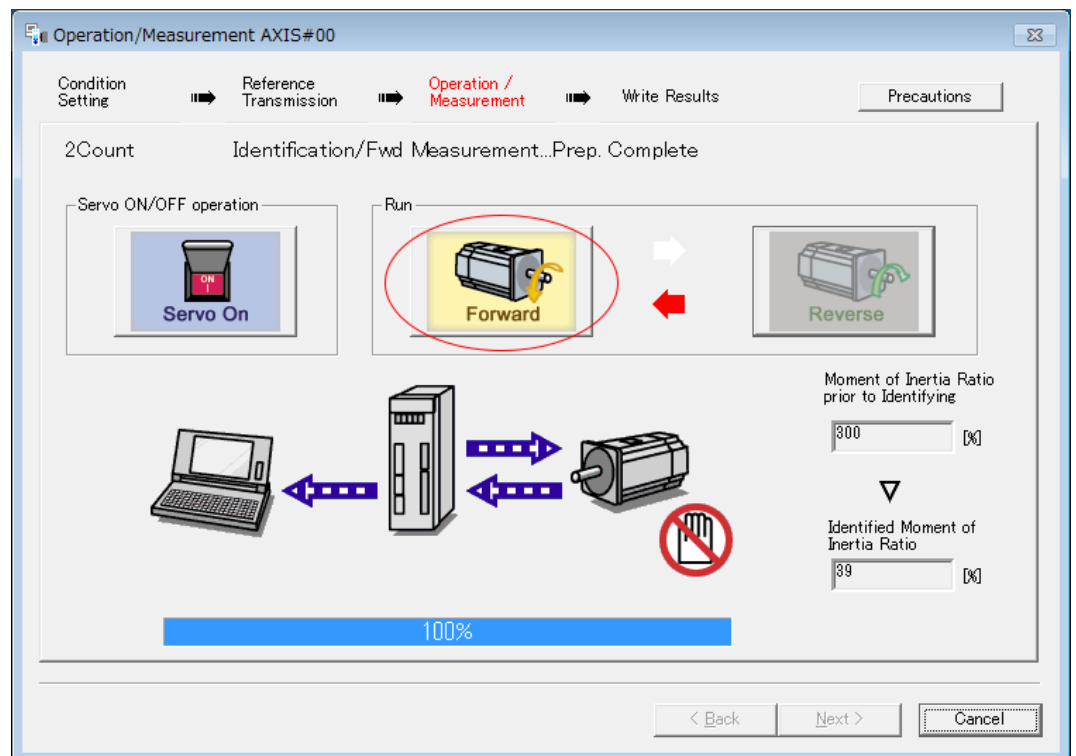


Fig. 233: Tuning - Operation/Measurement Dialog Box - Forward Button

- 12. Repeat steps 9 to 11 until the **Next** Button is enabled.

Measurements are performed from 2 to 7 times and then verified. The number of measurements is displayed in upper left corner of the dialog box. A progress bar at the bottom of the dialog box will show the progress of the transfer each time.

- 13. When the measurements have been completed, click the **Servo On** Button to turn OFF the servo.

- 14. Click the **Next** Button.

The Write Results Dialog Box will be displayed.

i If you click the **Next** Button before you turn OFF the servo, the following Dialog Box will be displayed. Click the **OK** Button to turn OFF the servo.

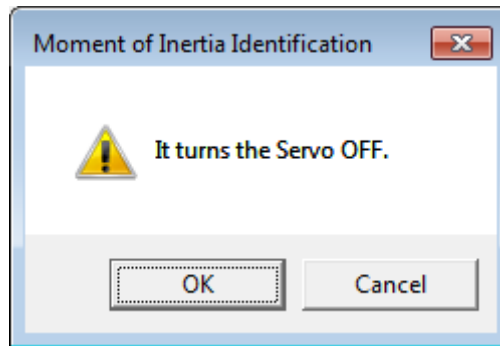


Fig. 234: Tuning - Moment of Inertia Identification - It turns the Servo OFF Box

- 15. Click the **Writing Results** Button.

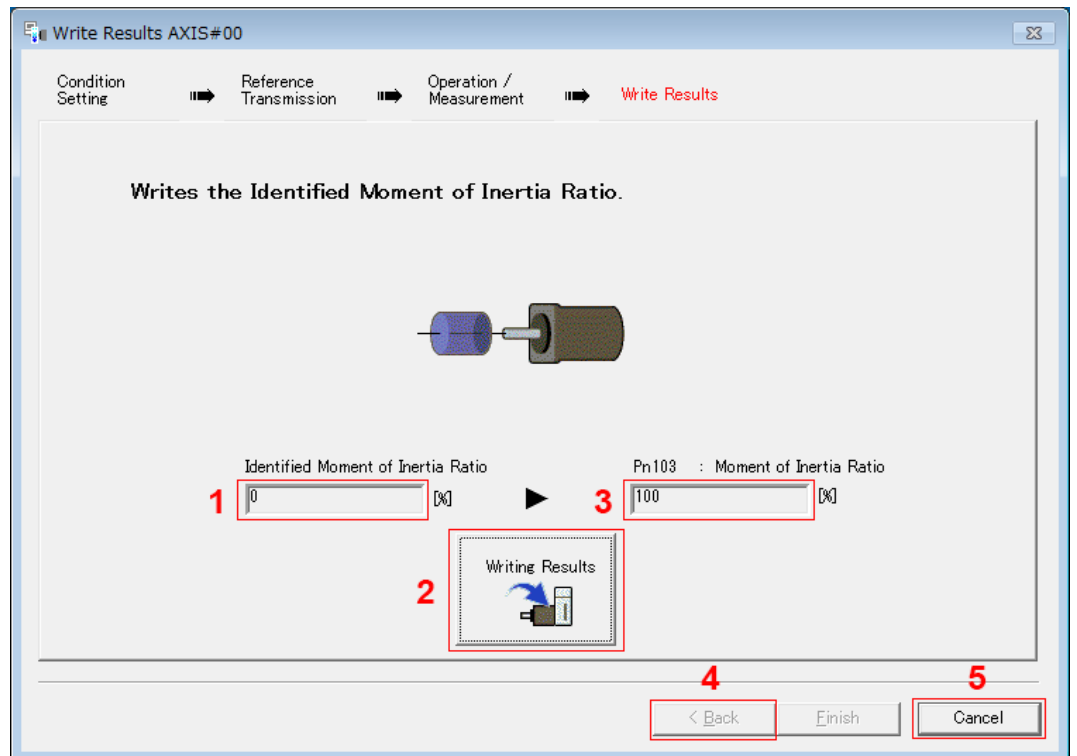


Fig. 235: Tuning - Write Results AXIS#00

- ➔ 1 - Identified Moment of Inertia Ratio Box

The moment of inertia ratio that was found with operation and measurements is displayed here.

2 - Writing Results Button

If you click this button, Pn103 (Moment of Inertia Ratio) in the SERVOPACK is set to the value that is displayed for the identified moment of inertia ratio.

3 - Pn103: Moment of Inertia Ratio Box

The value that is set for the parameter is displayed here.

After you click the **Writing Results** Button, the value that was found with operation and measurements will be displayed as the new setting.

4 - Back Button

This button is disabled.

5 - Cancel Button

This button will return you to the Tuning Dialog Box.

16. Confirm that the **Identified Moment of Inertia Ratio** Box and the **Pn103: Moment of Inertia Ratio** Box show the same value and then click the **Finish** Button.

17. Click the **OK** Button.

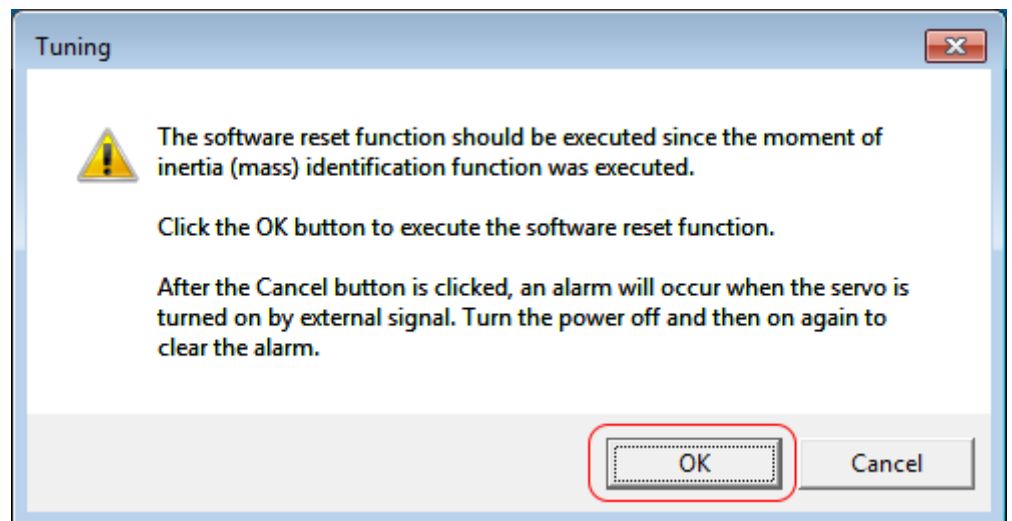


Fig. 236: Tuning - Software Reset Function Information

18. Click the **Execute** Button.

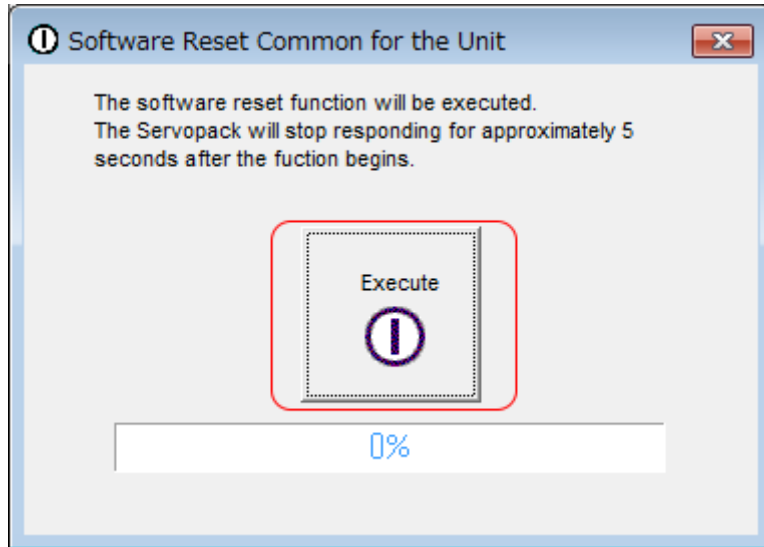


Fig. 237: Tuning - Software Reset Common for the Unit - Execute Button

- ➔ If the setting of the moment of inertia ratio (Pn103) was changed, the new value will be saved and the Tuning Dialog Box will be displayed again.

This concludes the procedure to estimate the moment of inertia ratio.

9.7 Autotuning without Host Reference

9.7.1 Overview

This section describes autotuning without a host reference.



- *Autotuning without a host reference performs adjustments based on the setting of the speed loop gain (Pn100). Therefore, precise adjustments cannot be made if there is vibration when adjustments are started. Make adjustments after lowering the speed loop gain (Pn100) until vibration is eliminated.*
- *You cannot execute autotuning without a host reference if the tuning-less function is enabled (Pn170 = n.□□□1 (default setting)). Disable the tuning-less function (Pn170 = n.□□□0) before you execute autotuning without a host reference.*
- *If you change the machine load conditions or drive system after you execute autotuning without a host reference and then you execute autotuning without a host reference with moment of inertia estimation specified, use the following parameter settings. If you execute autotuning without a host reference for any other conditions, the machine may vibrate and may be damaged.*
Pn140 = n.□□□0 (Do not use model following control.)
Pn160 = n.□□□0 (Do not use anti-resonance control.)
Pn408 = n.00□0 (Disable friction compensation, first stage notch filter, and second stage notch filter.)
Note: If you are using the Digital Operator and the above parameters are not displayed, change the parameter display setting to display all parameters (Pn00B = n.□□□1) and then turn the power supply OFF and ON again.

9.7.2 Outline

For autotuning without a host reference, operation is automatically performed by the SERVOPACK for round-trip (forward and reverse) operation to adjust for machine characteristics during operation. A reference from the host controller is not used.

The following items are adjusted automatically.

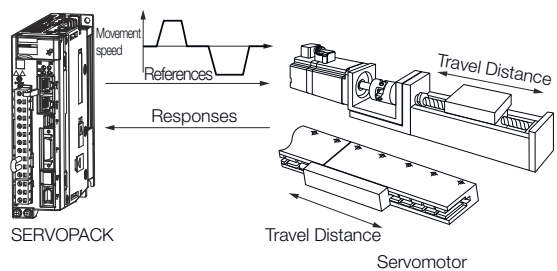
- Moment of inertia ratio
- Gains (e.g., speed loop gain and position loop gain)
- Filters (torque reference filter and notch filters)
- Friction compensation
- Anti-resonance control
- Vibration suppression (only for mode 2 or 3)

Refer to the following section for details on the parameters that are adjusted.

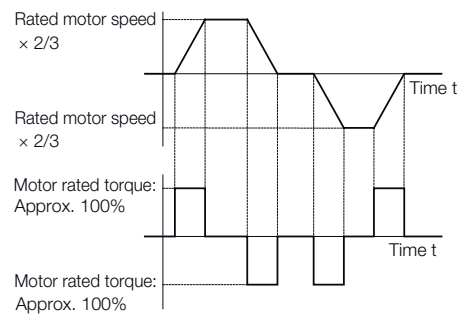
→ [Chap. 9.7.8 'Related Parameters' ...page 321](#)

The Servomotor is operated with the following specifications.

Maximum Speed	Rated motor speed x 2/3	
Acceleration Torque	Rated motor torque: Approx. 100%	
Travel Distance	Rotary Servomotors	You can set the desired travel distance. The default setting is for a value equivalent to 3 Servomotor shaft rotations.
	Direct Drive Servomotors	You can set the desired travel distance. The default setting is for a value equivalent to 0.3 rotations.
	Linear Servomotors	You can set the desired travel distance in increments of 1,000 reference units. (The default setting is for 90 mm.)



Note: Execute autotuning without a host reference after jogging to a position that ensures a suitable range of motion.



Example of Automatic Operation Pattern

Fig. 238: Autotuning without Host Reference

**WARNING**

Autotuning without a host reference requires operating the Servomotor and therefore presents hazards. Observe the following precaution.

- Confirm safety around moving parts.

This function involves automatic operation with vibration. Make sure that you can perform an emergency stop (to turn OFF the power supply) at any time. There will be movement in both directions within the set range of movement. Check the range of movement and the directions and implement protective controls for safety, such as the overtravel functions.

9.7.3 Restrictions

The following restrictions apply to autotuning without a host reference.

If you cannot use autotuning without a host reference because of these restrictions, use autotuning with a host reference or custom tuning. Refer to the following sections for details.

→ [Chap. 9.8.1 'Autotuning with a Host Reference' ...page 322](#)

→ [Chap. 9.9.1 'Custom Tuning' ...page 332](#)

Systems for Which Execution Cannot Be Performed

- When the machine system can move only in one direction
- When the range of motion is 0.5 rotations or less

Systems for Which Adjustments Cannot Be Made Accurately

- When a suitable range of motion is not possible
 - When the moment of inertia changes within the set operating range
 - When the machine has high friction
 - When the rigidity of the machine is low and vibration occurs when positioning is performed
 - When the position integration function is used
 - When proportional control is used
 - When mode switching is used
- Note: If you specify moment of inertia estimation, mode switching will be disabled and PI control will be used while the moment of inertia is being calculated. Mode switching will be enabled after moment of inertia estimation has been completed.
- When speed feedforward or torque feedforward is input
 - When the positioning completed width (Pn522) is too narrow

Preparations

Check the following settings before you execute autotuning without a host reference.

- The main circuit power supply must be ON.
- There must be no overtravel.
- The servo must be OFF.
- The control method must not be set to torque control.
- The gain selection switch must be set to manual gain selection (Pn139 = n.□□□0).
- The first gains must be selected.
- The test without a motor function must be disabled (Pn00C = n.□□□0).
- There must be no alarms or warnings.
- There must be no hard wire base block (HWBB).
- The parameters must not be write prohibited.

- The tuning-less function must be disabled (Pn170 = n.□□□0), or the tuning-less function must be enabled (Pn170 = n.□□□1) (default setting) and moment of inertia estimation must be specified.
- If you execute autotuning without a host reference during speed control, set the mode to 1.



If you start autotuning without a host reference while the SERVOPACK is in speed control for mode 2 or 3, the SERVOPACK will change to position control automatically to perform autotuning without a host reference. The SERVOPACK will return to speed control after autotuning has been completed.

9.7.4 Applicable Tools

The following table lists the tools that you can use to perform autotuning without a host reference and the applicable tool functions.

Tool	Function	Operating Procedure Reference
Digital Operator	Fn201	Σ-7-Series Digital Operator Operating Manual (Manual No.: SIEP S800001 33)
SigmaWin+	Tuning - Tuning	→ Chap. 9.7.5 'Operating Procedure' ...page 309


9.7.5 Operating Procedure

Use the following procedure to perform autotuning without a host reference.



CAUTION

If you specify not estimating the moment of inertia, set the moment of inertia ratio (Pn103) correctly. If the setting greatly differs from the actual moment of inertia ratio, normal control of the machine may not be possible, and vibration may result.

1. → Confirm that the moment of inertia ratio (Pn103) is set correctly.
2. → Click the  Servo Drive Button in the workspace of the Main Window of the SigmaWin+.
3. → Select **Tuning** in the Menu Dialog Box.
 - ➔ The Tuning Dialog Box will be displayed. Click the **Cancel** Button to cancel tuning.

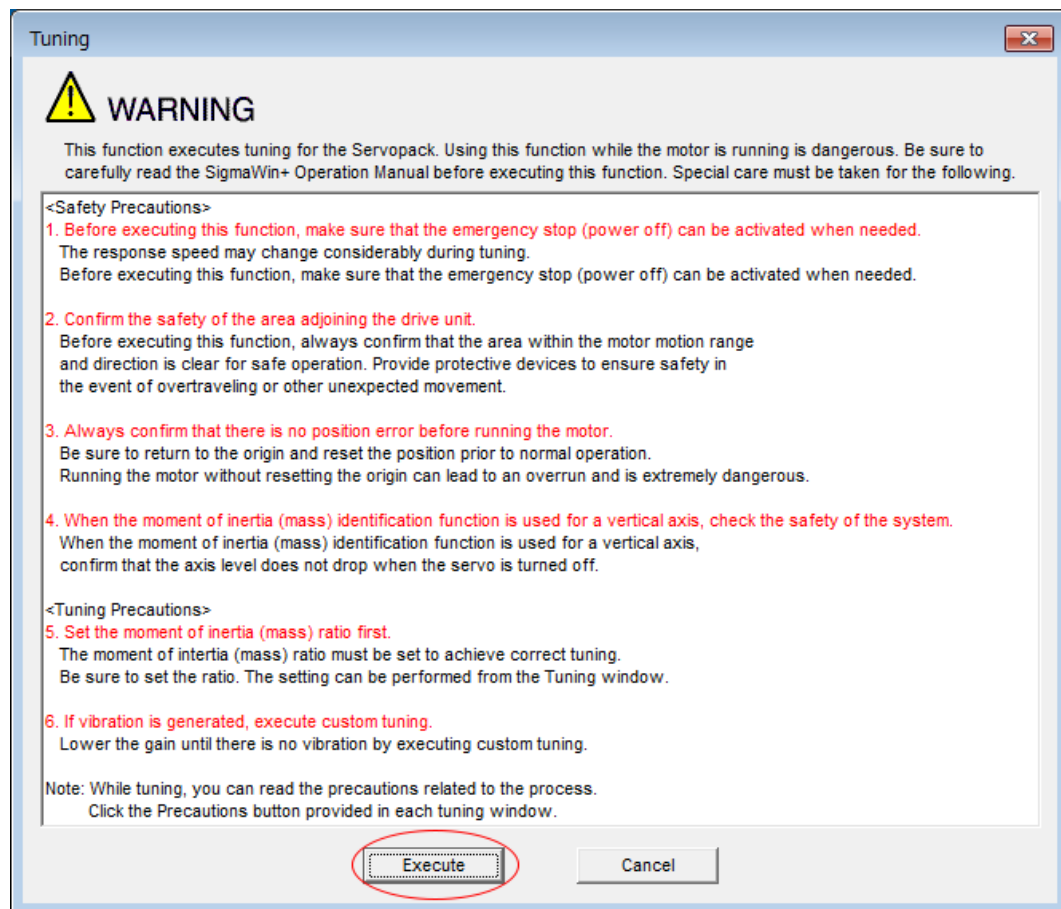
4. Click the **Execute** Button.

Fig. 239: Tuning - Warning

5. → Select the **No Reference Input** Option in the **Autotuning** Area and then click the **Autotuning** Button.

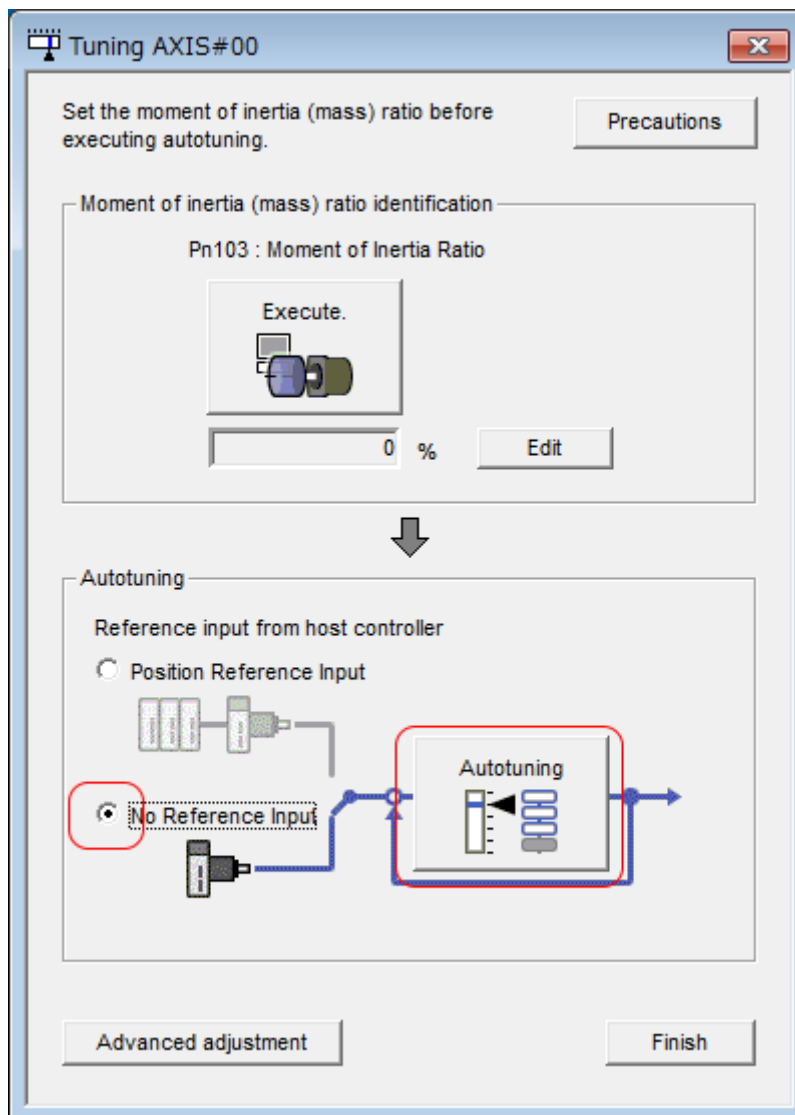


Fig. 240: Tuning AXIS#00 - Autotuning - No Reference Input



When the following dialog box is displayed, click the **OK** Button and then verify and confirm that the correct moment of inertia ratio is set in Pn103 (Moment of Inertia Ratio).

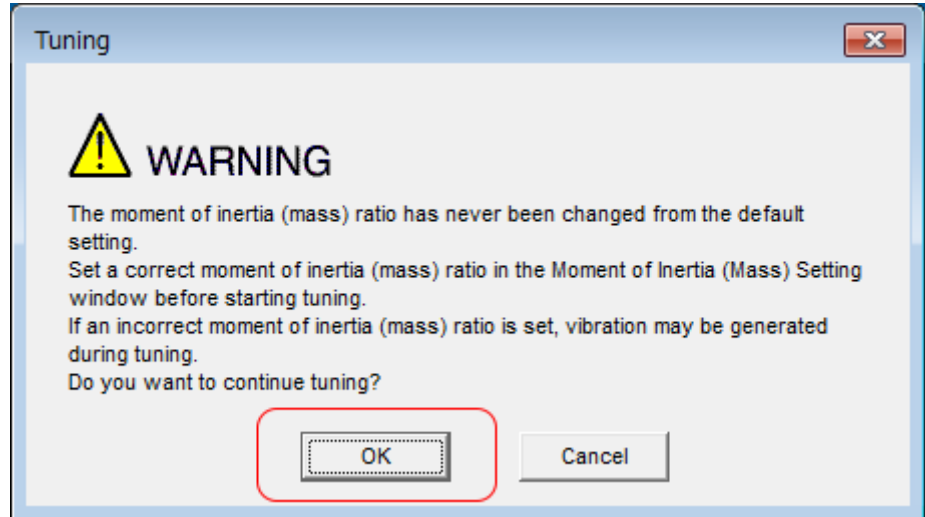


Fig. 241: Tuning - Warning - The Moment of Inertia Ratio has never been changed from the default setting

6. → Set the conditions in the **Switching the load moment of inertia (load mass) identification** Box, the **Mode selection** Box, the **Mechanism selection** Box, and the **Distance** Box, and then click the **Next** Button.

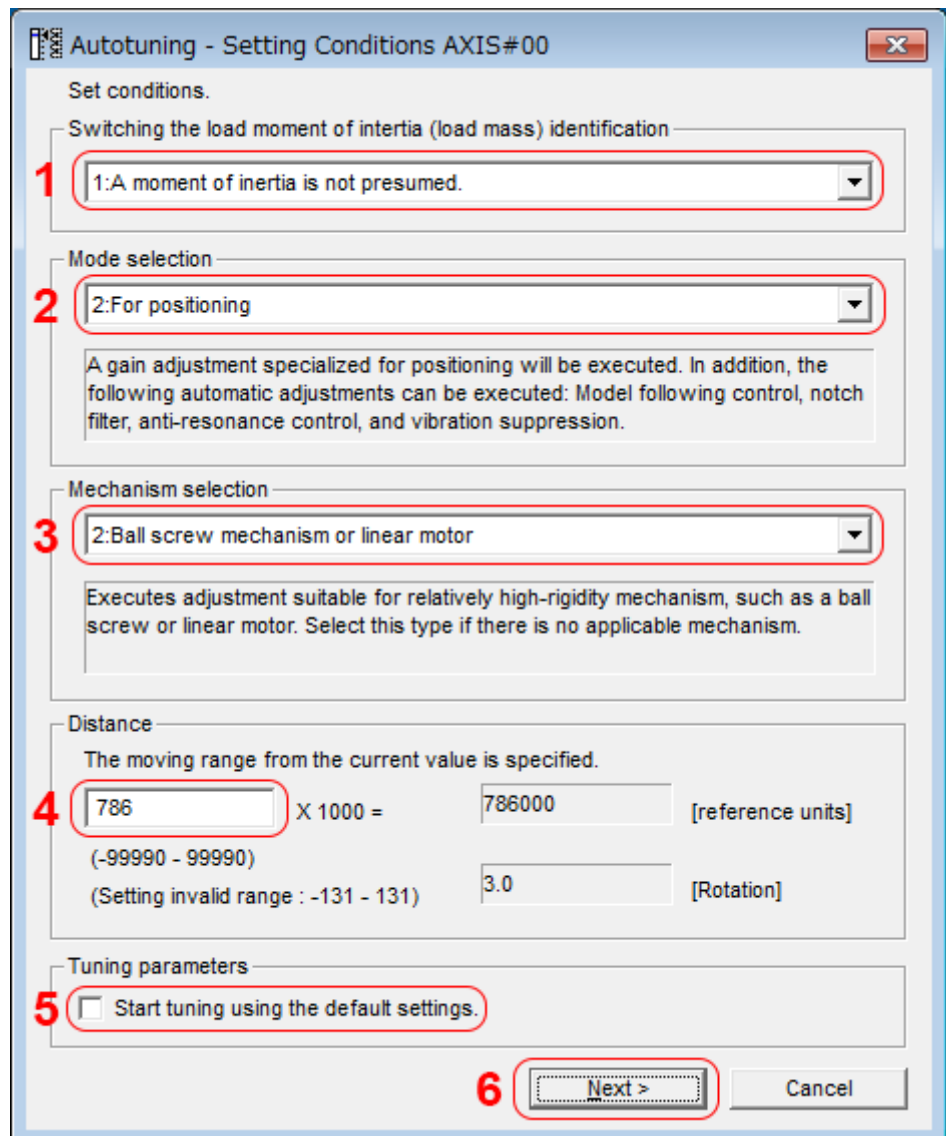


Fig. 242: Autotuning - Setting Conditions AXIS#00

➔ 1 - Switching the load moment of inertia (load mass) identification Box

Specify whether to estimate the moment of inertia.

0: A moment of inertia is presumed. (default setting)

1: A moment of inertia is not presumed.

2 - Mode selection Box

Set the mode.

■ 1: Standard

Standard gain adjustment is performed. In addition to gain adjustment, notch filters and anti-resonance control are automatically adjusted.

■ 2: For positioning

Tuning is performed for positioning applications. In addition to gain adjustment, model following control, notch filters, anti-resonance control, and vibration suppression are automatically adjusted.

■ 3: For positioning especially to prevent overshooting

Tuning is performed for positioning applications with emphasis on eliminating overshooting. In addition to gain adjustment, notch filters, antiresonance control, and vibration suppression are automatically adjusted.

3 - Mechanism selection Box

Select the type according to the machine element to drive.

If there is noise or if the gain does not increase, better results may be obtained by changing the rigidity type. Select the type according to the following guidelines.

■ 1: Belt mechanism

Tuning is performed for a mechanism with relatively low rigidity, e.g., a belt.

■ 2: Ball screw mechanism or linear motor

Tuning is performed for a mechanism with relatively high rigidity, e.g., a ball screw or Linear Servomotor. Use this setting if there is no other appropriate setting.

■ 3: Rigid model

Tuning is performed for a mechanism with high rigidity, e.g., a rigid body system.

4 - Distance Box

Set the travel distance.

Movement range: -99,990,000 to +99,990,000 [reference units]

Minimum setting increment for travel distance: 1,000 [reference units]

Negative values are for reverse operation and positive values are for forward operation from the current position.

Default settings:

Rotary Servomotors: Approx. 3 rotations

Direct Drive Servomotors: Approx. 0.3 rotations

Linear Servomotors: Approx 90 mm

Set the distance to the following values or higher. To ensure tuning precision, we recommend that you use approximately the default distance setting.

Rotary Servomotors: 0.5 rotations

Direct Drive Servomotors: 0.05 rotations

Linear Servomotors: 5 mm

5 - Tuning parameters Box

Specify the parameters to use for tuning.

If you select the **Start tuning using the default settings** Check Box, the tuning parameters will be returned to the default settings before tuning is started.

6 - Next Button

7. Click the **Servo ON** Button.



Fig. 243: Autotuning - Automatic Setting AXIS#00 - Servo ON

8. Click the **Start tuning** Button.

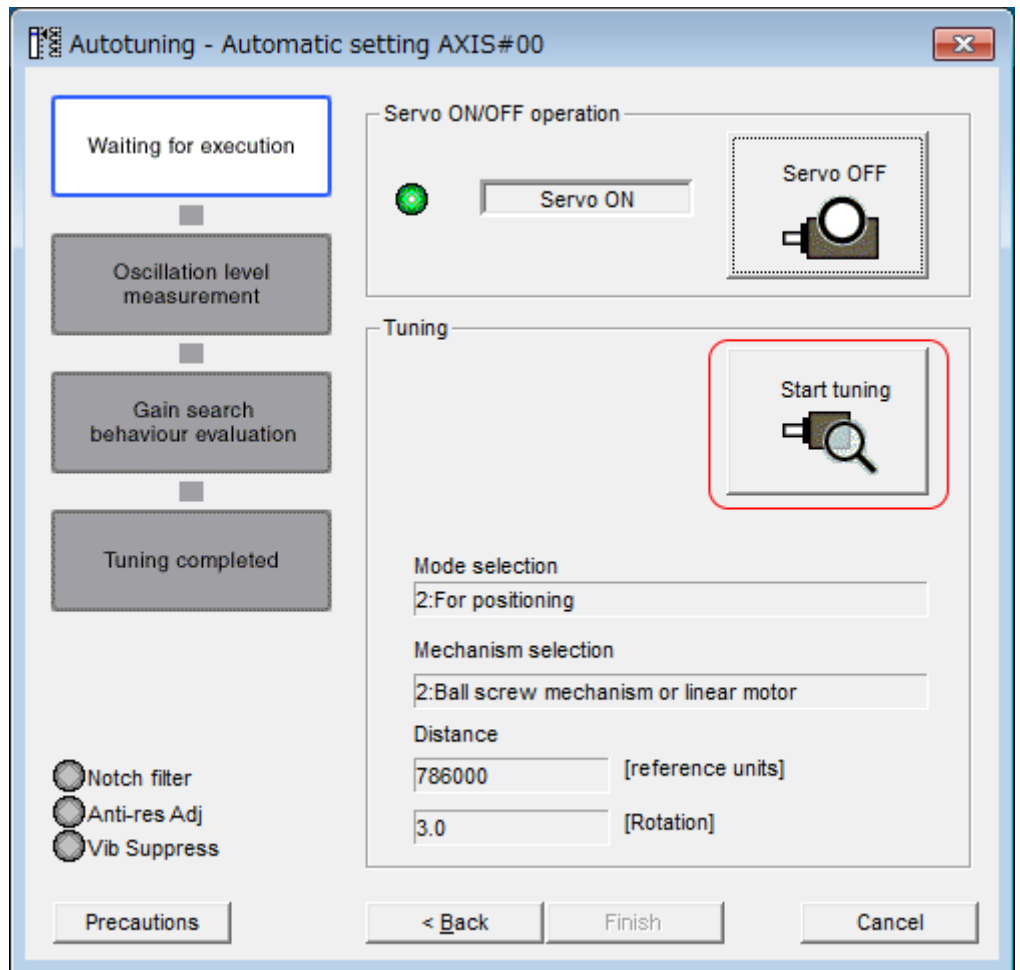


Fig. 244: Autotuning - Automatic Setting AXIS#00 - Start tuning

9. Confirm safety around moving parts and click the **Yes** Button.

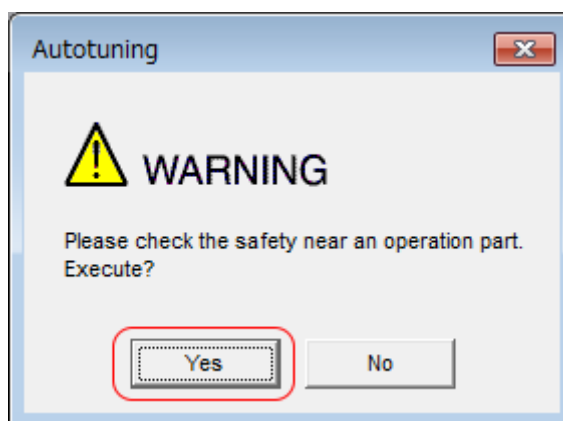


Fig. 245: Autotuning - Warning - Check safety

➔ The Servomotor will start operating and tuning will be executed.

Vibration that occurs during tuning will be detected automatically and suitable settings will be made for that vibration. When the settings have been completed, the indicators for the functions that were used will light at the lower left of the dialog box.

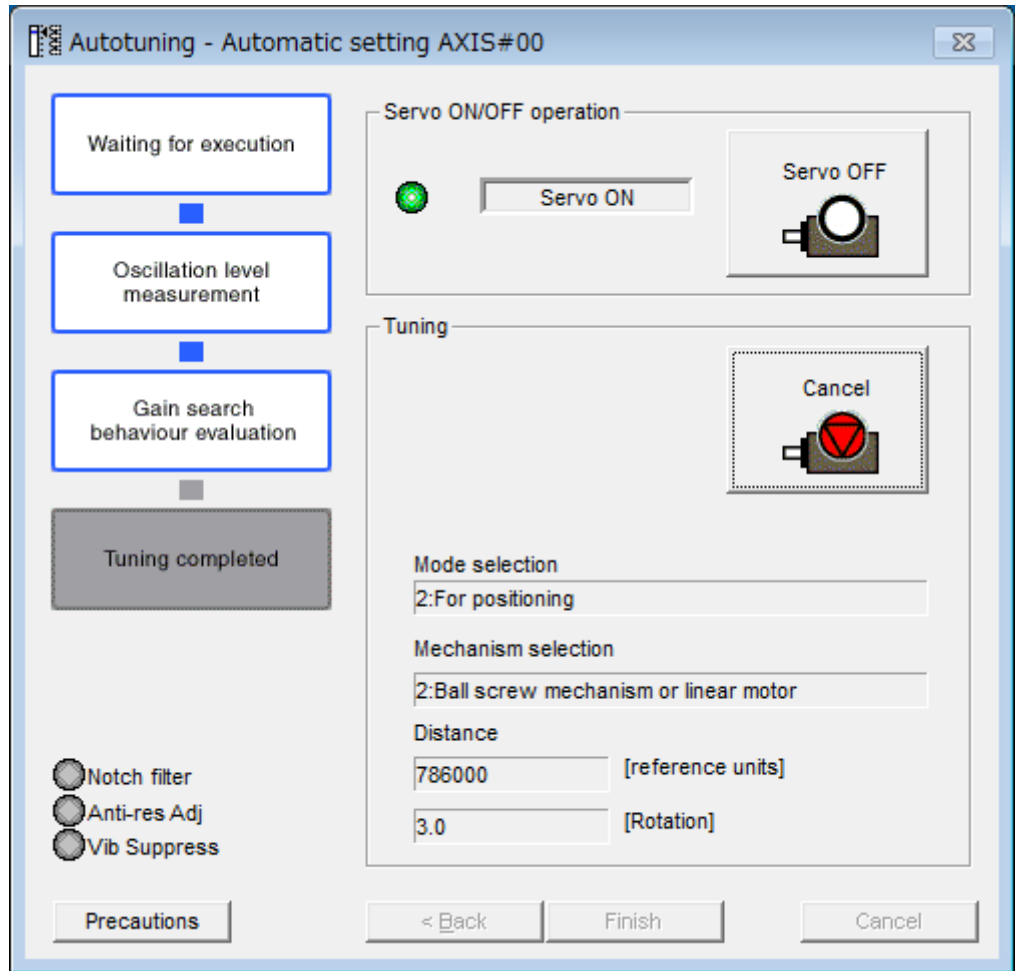


Fig. 246: Autotuning - Execution in Progress

10. When tuning has been completed, click the **Finish** Button.

- ➔ The results of tuning will be set in the parameters and you will return to the Tuning Dialog Box.

This concludes the procedure to perform autotuning without a host reference.

9.7.6 Troubleshooting Problems in Autotuning without a Host Reference

The following tables give the causes of and corrections for problems that may occur in autotuning without a host reference.

Autotuning without a Host Reference Was Not Performed

Possible Cause	Corrective Action
Main circuit power supply is OFF.	Turn ON the main circuit power supply.
An alarm or warning occurred.	Remove the cause of the alarm or warning.
Overtraveling occurred.	Remove the cause of overtraveling.
The second gains were selected with the gain selection.	Disable automatic gain switching.
The HWBB was activated.	Release the HWBB.
The setting of the travel distance is too small.	Set the travel distance again in step 6 of the procedure.

Possible Cause	Corrective Action
The settings for the tuning-less function are not correct.	<ul style="list-style-type: none"> Disable the tuning-less function (Pn170 = n.□□□0). Enable the tuning-less function (Pn170 = n.□□□1) and specify moment of inertia estimation.

When an Error Occurs during Execution of Autotuning without a Host Reference

Error	Possible Cause	Corrective Action
The gain adjustments were not successfully completed.	Machine vibration occurs or the positioning completion signal is not stable when the Servomotor stops.	<ul style="list-style-type: none"> Increase the setting of the positioning completed width (Pn522). Change the mode from 2 to 3. If machine vibration occurs, suppress the vibration with the anti-resonance control adjustment and the vibration suppression function.
An error occurred during calculation of the moment of inertia.	Refer to the following section for troubleshooting information. ↪ 'When an Error Occurs during Calculation of Moment of Inertia' ...page 317	
Positioning was not completed within approximately 10 seconds after position adjustment was completed.	The positioning completed width is too narrow or proportional control is being used.	Increase the setting of the positioning completed width (Pn522).

When an Error Occurs during Calculation of Moment of Inertia

Possible Cause	Corrective Action
The SERVOPACK started calculating the moment of inertia but the calculation was not completed.	<ul style="list-style-type: none"> Increase the setting of the speed loop gain (Pn100). Increase the stroke (travel distance).
The moment of inertia fluctuated greatly and did not converge within 10 tries.	Set Pn103 (Moment of Inertia Ratio) from the machine specifications and specify not estimating the moment of inertia.
Low-frequency vibration was detected.	Double the setting of moment of inertia calculation starting level (Pn324).
The torque limit was reached.	<ul style="list-style-type: none"> If you are using the torque limit, increase the torque limit. Double the setting of moment of inertia calculation starting level (Pn324).
Speed control changed to proportional control during calculation of the moment of inertia.	Use PI control when calculating the moment of inertia.

Adjustment Results Are Not Satisfactory for Position Control

You may be able to improve the adjustment results by changing the settings of the positioning completed width (Pn522) and position reference unit (*position user unit* (2301h)). If satisfactory results are still not possible, adjust the overshoot detection level (Pn561). That may improve the adjustment results.

- Pn561 = 100% (default setting)
This will allow tuning with overshooting that is equivalent to the positioning completed width.
- Pn561 = 0%
This will allow tuning to be performed without overshooting within the positioning completed width, but the positioning completed width may be extended.

Overshoot Detection Level

	Setting Range	Setting Unit	Default Setting	When Enabled	Classification
Pn561	0 to 100	1%	100	Immediately	Setup

(applies to Speed Control, Position Control and Torque Control)

9.7.7 Automatically Adjusted Function Settings

You can specify whether to automatically adjust the following functions during autotuning.

Automatic Notch Filters

Normally, set Pn460 to n.□1□□ (Adjust automatically) (default setting).

Vibration will be detected during autotuning without a host reference and a notch filter will be adjusted.

Set Pn460 to n.□0□□ (Do not adjust automatically) only if you do not change the setting of the notch filter before you execute this function.

Parameter	Meaning	When Enabled	Classification
Pn460	n.□□□0	Immediately	Tuning
	n.□□□1 (default setting)		
	n.□0□□		

Parameter	Meaning	When Enabled	Classification
n.□1□□ (default setting)	Adjust the second stage notch filter automatically when the tuning-less function is enabled or during execution of autotuning without a host reference, autotuning with a host reference, and custom tuning.		

Anti-Resonance Control Adjustment

This function reduces low vibration frequencies, for which the notch filters cannot be used.

Normally, set Pn160 to n.□□1□ (Adjust automatically) (default setting).

Vibration will be detected during autotuning without a host reference and anti-resonance control will be automatically adjusted.

Parameter	Meaning	When Enabled	Classification
Pn160	n.□□0□	Immediately	Tuning
	n.□□1□ (default setting)		

Vibration Suppression

You can use vibration suppression to suppress transitional vibration at a low frequency from 1 Hz to 100 Hz, which is generated mainly when the machine vibrates during positioning.

Normally, set Pn140 to n.□1□□ (Adjust automatically) (default setting).

Vibration will be detected during autotuning without a host reference and vibration suppression control will be automatically set.

Set Pn140 = n.□0□□ (Do not adjust automatically) only if you do not change the settings for vibration suppression before you execute autotuning without a host reference.

Note: Autotuning without a host reference uses model following control. Therefore, it can be executed only if the mode is set to 2 or 3.

Parameter	Meaning	When Enabled	Classification
Pn140	n.□0□□	Immediately	Tuning

Parameter	Meaning	When Enabled	Classification
n. 1□□□ (default setting)	Adjust vibration suppression automatically during execution of autotuning without a host reference, autotuning with a host reference, and custom tuning.		

Friction Compensation

Friction compensation compensates for changes in the following conditions.

- Changes in the viscous resistance of the lubricant, such as grease, on the sliding parts of the machine
- Changes in the friction resistance resulting from variations in the machine assembly
- Changes in the friction resistance due to aging

The conditions for applying friction compensation depend on the mode selection.

Mode Selection Settings	Friction Compensation
1: Standard	Based on the setting of Pn408 = n.X□□□ (Friction Compensation Function Selection)*
2: For position control	Adjusted with friction compensation.
3: For position control (emphasis on overshooting)	

Parameter	Meaning	When Enabled	Classification
Pn408	n. 0□□□ (default setting)	Immediately	Setup
	n. 1□□□		

* Refer to the following section for details.

➔ [Chap. 9.13.3 'Friction Compensation' ...page 374](#)

Feedforward

If Pn140 is set to n.0□□□ (Do not use model following control and speed/torque feedforward together (default setting)) and tuning is performed with the mode selection set to 2 or 3, feedforward (Pn109), the speed feedforward input (VFF), and the torque feedforward input (TFF) will be disabled.

To use the speed feedforward input (VFF), the torque feedforward input (TFF), and model following control from the host controller in the system, set Pn140 to n.1□□□ (Use model following control and speed/torque feedforward together).

Parameter	Meaning	When Enabled	Classification
Pn140	n.0□□□ (default setting)	Immediately	Tuning
	n.1□□□		



When model following control is used with the feedforward function, it is used to make optimum feedforward settings in the SERVOPACK. Therefore, model following control is not normally used together with either the speed feedforward input (VFF) or torque feedforward input (TFF) from the host controller. However, model following control can be used with the speed feedforward input (VFF) or torque feedforward input (TFF) if required. An unsuitable feedforward input may result in overshooting.

9.7.8 Related Parameters

The following parameters are automatically adjusted or used as reference when you execute autotuning without a host reference.

Do not change the settings while autotuning without a host reference is being executed.

Parameter	Name	Automatic Changes
Pn100	Speed Loop Gain	Yes
Pn101	Speed Loop Integral Time Constant	Yes
Pn102	Position Loop Gain	Yes
Pn103	Moment of Inertia Ratio	Yes
Pn121	Friction Compensation Gain	Yes
Pn123	Friction Compensation Coefficient	Yes
Pn124	Friction Compensation Frequency Correction	No
Pn125	Friction Compensation Gain Correction	Yes
Pn401	First Stage First Torque Reference Filter Time Constant	Yes
Pn408	Torque-Related Function Selections	Yes
Pn409	First Stage Notch Filter Frequency	Yes
Pn40A	First Stage Notch Filter Q Value	Yes
Pn40C	Second Stage Notch Filter Frequency	Yes
Pn40D	Second Stage Notch Filter Q Value	Yes
Pn140	Model Following Control-Related Selections	Yes
Pn141	Model Following Control Gain	Yes
Pn142	Model Following Control Gain Correction	Yes
Pn143	Model Following Control Bias in the Forward Direction	Yes
Pn144	Model Following Control Bias in the Reverse Direction	Yes
Pn145	Vibration Suppression 1 Frequency A	Yes
Pn146	Vibration Suppression 1 Frequency B	Yes
Pn147	Model Following Control Speed Feedforward Compensation	Yes
Pn160	Anti-Resonance Control-Related Selections	Yes
Pn161	Anti-Resonance Frequency	Yes
Pn163	Anti-Resonance Damping Gain	Yes
Pn531	Program Jogging Travel Distance	No

Parameter	Name	Automatic Changes
Pn533	Program Jogging Movement Speed for Rotary Servo-motor	No
Pn585	Program Jogging Movement Speed for Linear Servo-motor	No
Pn534	Program Jogging Acceleration/Deceleration Time	No
Pn535	Program Jogging Waiting Time	No
Pn536	Program Jogging Number of Movements	No

Yes: The parameter is automatically set.

No: The parameter is not automatically set, but the setting is read during execution.

9.8 Autotuning with a Host Reference

9.8.1 Overview

This section describes autotuning with a host reference.



Autotuning with a host reference makes adjustments based on the set speed loop gain (Pn100). Therefore, precise adjustments cannot be made if there is vibration when adjustments are started. Make adjustments after lowering the speed loop gain (Pn100) until vibration is eliminated.

9.8.2 Outline

Autotuning with a host reference automatically makes optimum adjustments for operation references from the host controller.

The following items are adjusted automatically.

- Gains (e.g., speed loop gain and position loop gain)
- Filters (torque reference filter and notch filters)
- Friction compensation
- Anti-resonance control
- Vibration suppression

Refer to the following section for details on the parameters that are adjusted.

→ [Chap. 9.8.8 'Related Parameters' ...page 331](#)

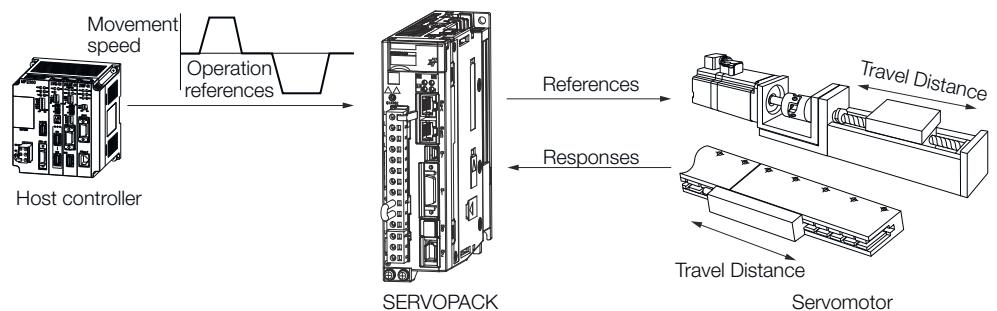


Fig. 247: Autotuning with a Host Reference

**CAUTION**

Because autotuning with a host reference adjusts the SERVOPACK during automatic operation, vibration or overshooting may occur. To ensure safety, make sure that you can perform an emergency stop at any time.

9.8.3 Restrictions

Systems for Which Adjustments Cannot Be Made Accurately

Adjustments will not be made correctly for autotuning with a host reference in the following cases. Use custom tuning.

- When the travel distance for the reference from the host controller is equal to or lower than the setting of the positioning completed width (Pn522)
- Rotary Servomotors: When the movement speed for the reference from the host controller is equal to or lower than the setting of the rotation detection level (Pn502)
- Linear Servomotors: When the movement speed for the reference from the host controller is equal to or lower than the setting of the zero speed level (Pn581)
- When the time required to stop is 10 ms or less
- When the rigidity of the machine is low and vibration occurs when positioning is performed
- When the position integration function is used
- When proportional control is used
- When mode switching is used
- When the positioning completed width (Pn522) is too narrow

Refer to the following sections for details on custom tuning.

→ [Chap. 9.9.1 'Custom Tuning' ...page 332](#)

Preparations

Check the following settings before you execute autotuning with a host reference.

- The servo must be in ready status.
- There must be no overtravel.
- The servo must be OFF.
- Position control must be selected if power is supplied to the motor (i.e., when the servo is ON).
- The gain selection switch must be set to manual gain selection (Pn139 = n.□□□0).
- The first gains must be selected.
- The test without a motor function must be disabled (Pn00C = n.□□□0).
- There must be no warnings.
- The tuning-less function must be disabled (Pn170 = n.□□□0).
- The parameters must not be write prohibited.


9.8.4 Applicable Tools

The following table lists the tools that you can use to perform autotuning with a host reference and the applicable tool functions.

Tool	Function	Operating Procedure Reference
Digital Operator	Fn202	Σ -7-Series Digital Operator Operating Manual (Manual No.: SIEP S800001 33)
SigmaWin+	Tuning - Tuning	→ Chap. 9.8.5 'Operating Procedure' ...page 324

9.8.5 Operating Procedure

Use the following procedure to perform autotuning with a host reference.

1. → Confirm that the moment of inertia ratio (Pn103) is set correctly.
2. → Click the  Servo Drive Button in the workspace of the Main Window of the SigmaWin+.
3. → Select **Tuning** in the Menu Dialog Box.
 - ➔ The Tuning Dialog Box will be displayed. Click the **Cancel** Button to cancel tuning.
4. → Click the **Execute** Button.
 - ➔

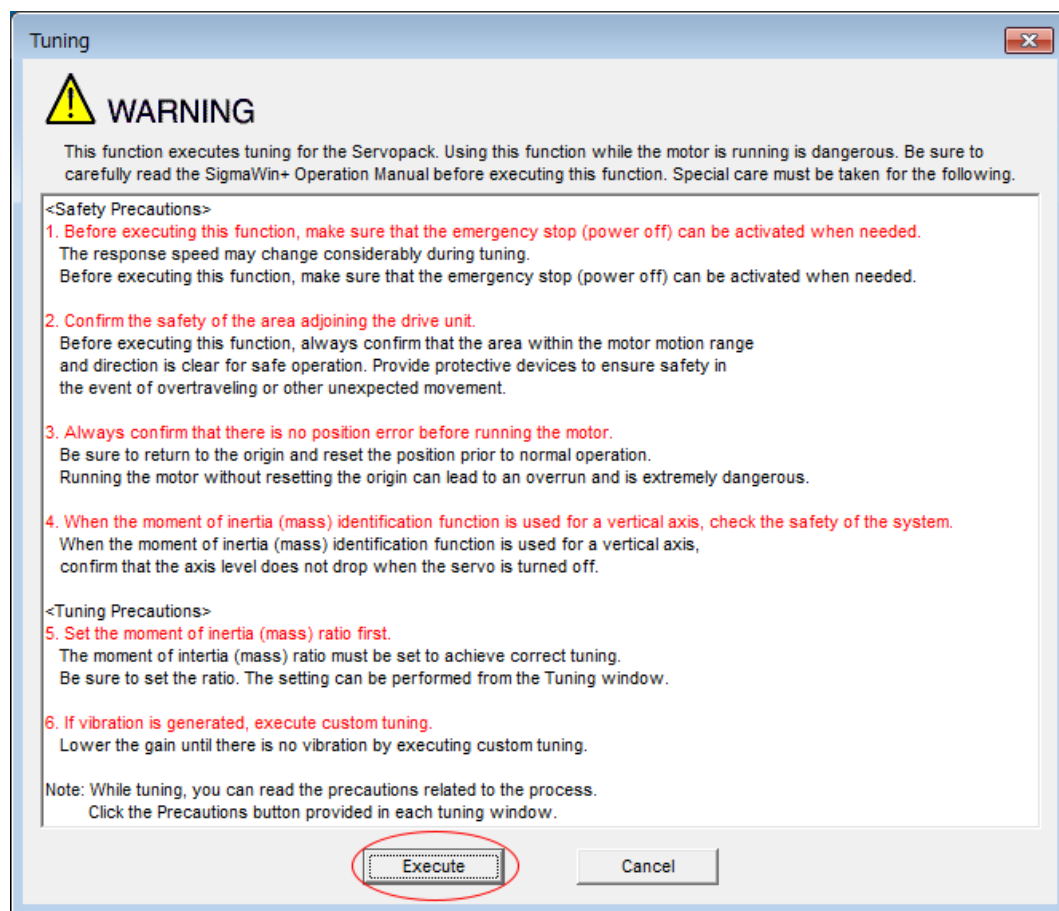


Fig. 248: Tuning - Warning

5. → Select the **Position reference input** Option in the **Autotuning** Area and then click the **Autotuning** Button.

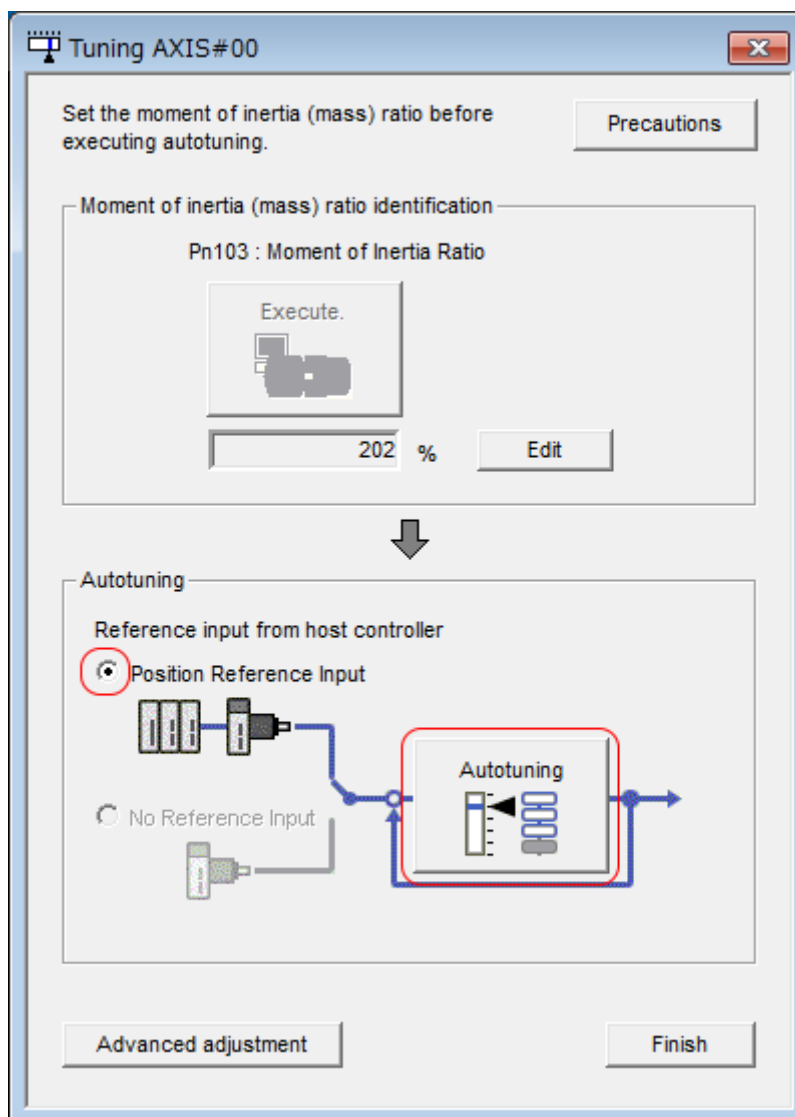


Fig. 249: Tuning AXIS#00 - Autotuning - Position Reference Input



When the following dialog box is displayed, click the **OK** Button and then confirm that the correct moment of inertia ratio is set in Pn103 (Moment of Inertia Ratio).

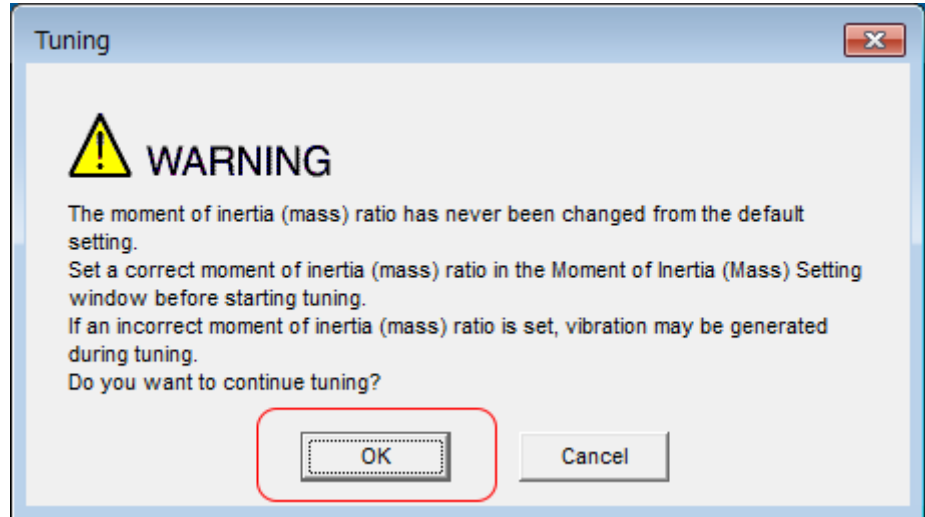


Fig. 250: Tuning - Warning - The Moment of Inertia Ratio has never been changed from the default setting

6. → Set the conditions in the **Mode selection** Box and the **Mechanism selection** Box, and then click the **Next** Button.

If you select the **Start tuning using the default settings** Check Box in the **Tuning parameters** Area, the tuning parameters will be returned to the default settings before tuning is started.

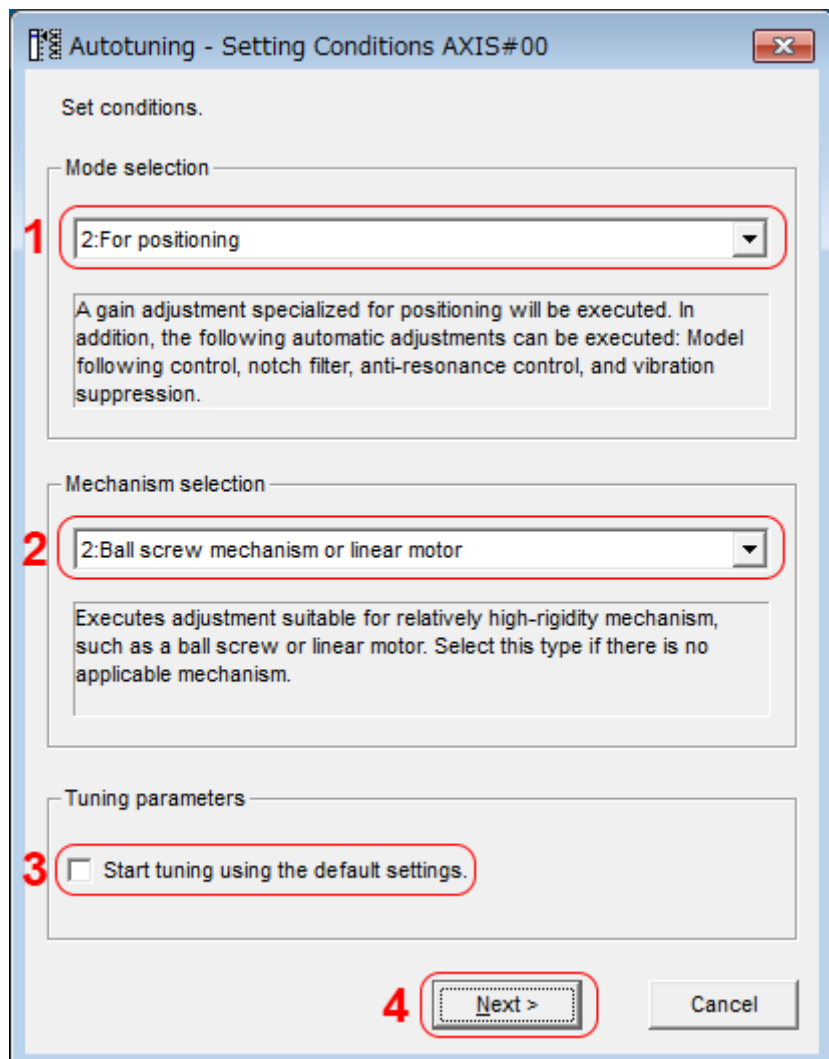


Fig. 251: Autotuning with a Host Reference - Setting Conditions AXIS#00

➔ 1 - Mode selection Box

Set the mode.

■ 1: Standard

Standard gain adjustment is performed. In addition to gain adjustment, notch filters and antiresonance control are automatically adjusted.

■ 2: For positioning

Tuning is performed for positioning applications. In addition to gain adjustment, model following control, notch filters, anti-resonance control, and vibration suppression are automatically adjusted.

■ 3: For positioning especially to prevent overshooting

Tuning is performed for positioning applications with emphasis on eliminating overshooting. In addition to gain adjustment, notch filters, antiresonance control, and vibration suppression are automatically adjusted.

2 - Mechanism selection Box

Select the type according to the machine element to drive.

If there is noise or if the gain does not increase, better results may be obtained by changing the rigidity type. Select the type according to the following guidelines.

■ 1: Belt mechanism

Tuning is performed for a mechanism with relatively low rigidity, e.g., a belt.

■ 2: Ball screw mechanism or linear motor

Tuning is performed for a mechanism with relatively high rigidity, e.g., a ball screw or Linear Servomotor. Use this setting if there is no other appropriate setting.

■ 3: Rigid model

Tuning is performed for a mechanism with high rigidity, e.g., a rigid body system.

3 - Tuning parameters Box

Specify the parameters to use for tuning.

If you select the **Start tuning using the default settings** Check Box, the tuning parameters will be returned to the default settings before tuning is started.

4 - Next Button

7. ➔ Click the **Yes** Button.

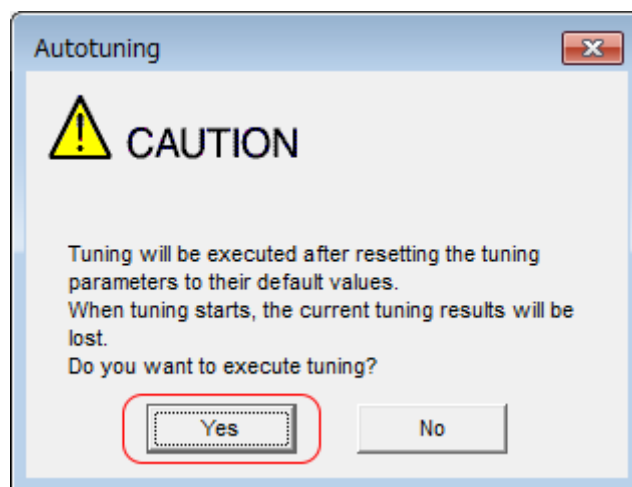



Fig. 252: Autotuning - CAUTION

8.  Input the correct moment of inertia ratio and click the **Next** Button.

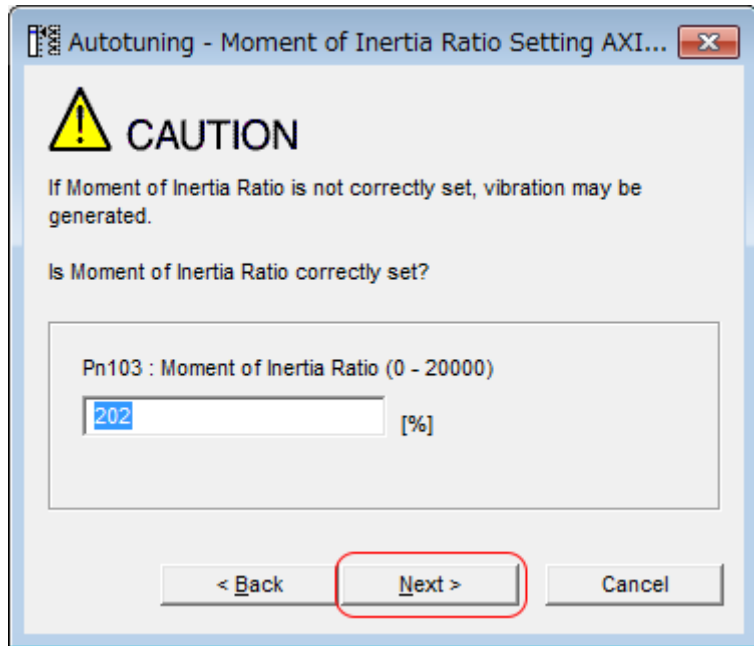


Fig. 253: Autotuning - Moment of Inertia Ratio Setting

9.  First confirm safety around moving parts. Turn ON the servo, enter a reference from the host controller, and then click the **Start tuning** Button.

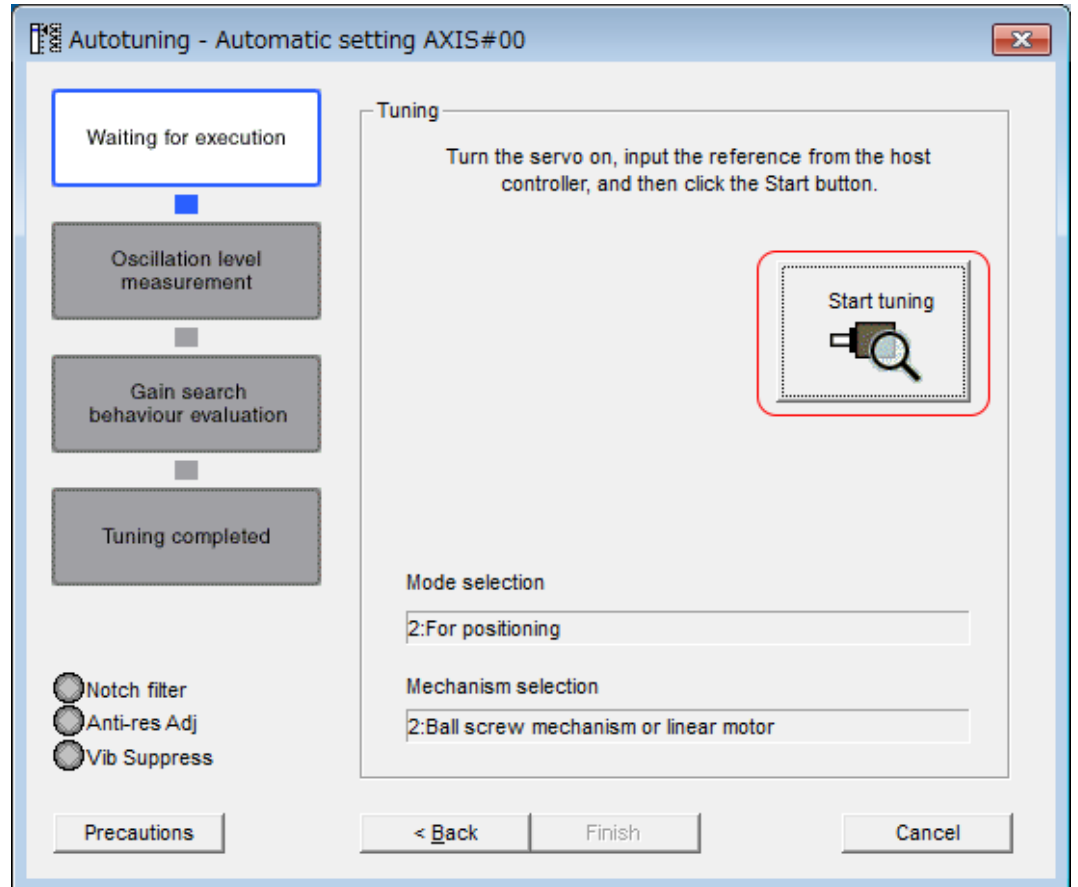


Fig. 254: Autotuning - Automatic Setting AXIS#00

10. Click the **Yes** Button.

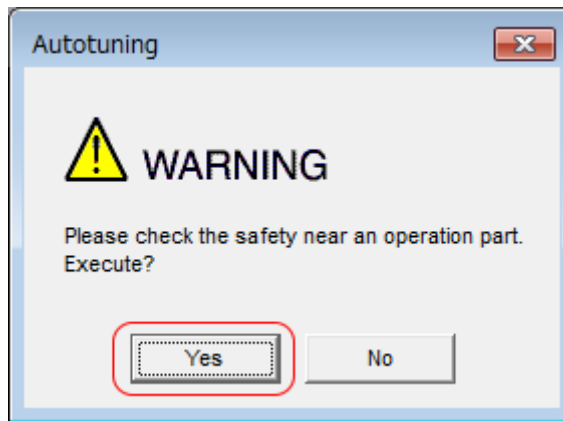


Fig. 255: Autotuning - Warning - Check safety

- ➔ Tuning will be executed.

Vibration that occurs during tuning will be detected automatically and suitable settings will be made for that vibration. When the settings have been completed, the indicators for the functions that were used will light at the lower left of the dialog box.

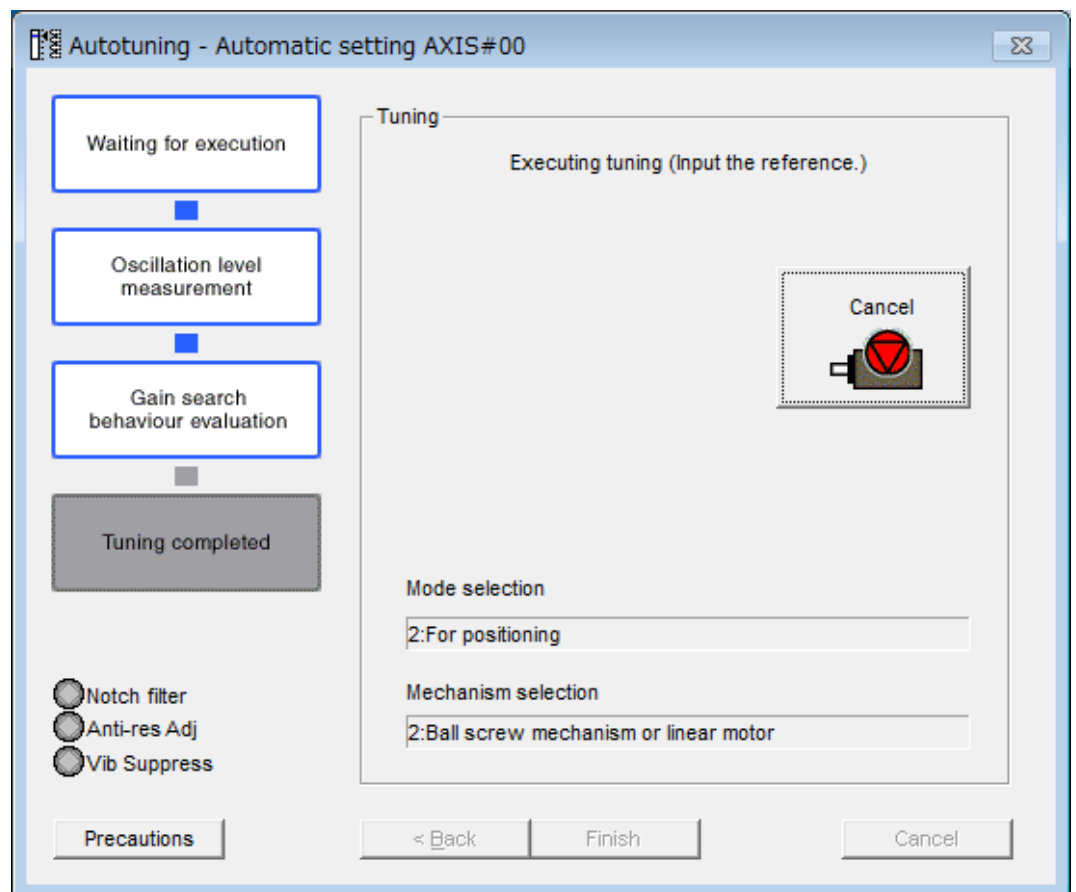


Fig. 256: Autotuning with a Host Reference - Execution in Progress

11. When tuning has been completed, click the **Finish** Button.

- ➔ The results of tuning will be set in the parameters and you will return to the Tuning Dialog Box.

This concludes the procedure to perform autotuning with a host reference.

9.8.6 Troubleshooting Problems in Autotuning with a Host Reference

The following tables give the causes of and corrections for problems that may occur in autotuning with a host reference.

Autotuning with a Host Reference Was Not Performed

Possible Cause	Corrective Action
Main circuit power supply is OFF.	Turn ON the main circuit power supply.
An alarm or warning occurred.	Remove the cause of the alarm or warning.
Overtraveling occurred.	Remove the cause of overtraveling.
The second gains were selected with the gain selection.	Disable automatic gain switching.
The HWBB was activated.	Release the HWBB.

Troubleshooting Errors

Error	Possible Cause	Corrective Action
The gain adjustments were not successfully completed.	Machine vibration occurs or the positioning completion signal is not stable when the Servomotor stops.	<ul style="list-style-type: none"> ■ Increase the setting of Pn522 (Positioning Completed Width). ■ Change the mode from 2 to 3. ■ If machine vibration occurs, suppress the vibration with the anti-resonance control adjustment and the vibration suppression function.
Positioning was not completed within approximately 10 seconds after position adjustment was completed.	The positioning completed width is too narrow or proportional control is being used.	Increase the setting of Pn522 (Positioning Completed Width).

Adjustment Results Are Not Satisfactory for Position Control

You may be able to improve the adjustment results by changing the settings of the positioning completed width (Pn522) and position reference unit (*position user unit* (2301h)).

If satisfactory results are still not possible, adjust the overshoot detection level (Pn561). That may improve the adjustment results.

- Pn561 = 100% (default setting)
This will allow tuning with overshooting that is equivalent to the positioning completed width.
- Pn561 = 0%
This will allow tuning to be performed without overshooting within the positioning completed width, but the positioning completed width may be extended.

Overshoot Detection Level

	Setting Range	Setting Unit	Default Setting	When Enabled	Classification
Pn561	0 to 100	1%	100	Immediately	Setup

(applies to Speed Control, Position Control and Torque Control)

9.8.7 Automatically Adjusted Function Settings

These function settings are the same as for autotuning without a host reference. Refer to the following section.

→ [Chap. 9.7.7 'Automatically Adjusted Function Settings' ...page 318](#)

9.8.8 Related Parameters

The following parameters are automatically adjusted or used as reference when you execute autotuning with a host reference.

Do not change the settings while autotuning with a host reference is being executed.

Parameter	Name	Automatic Changes
Pn100	Speed Loop Gain	Yes
Pn101	Speed Loop Integral Time Constant	Yes
Pn102	Position Loop Gain	Yes
Pn103	Moment of Inertia Ratio	No
Pn121	Friction Compensation Gain	Yes
Pn123	Friction Compensation Coefficient	Yes
Pn124	Friction Compensation Frequency Correction	No
Pn125	Friction Compensation Gain Correction	Yes
Pn401	First Stage First Torque Reference Filter Time Constant	Yes
Pn408	Torque-Related Function Selections	Yes
Pn409	First Stage Notch Filter Frequency	Yes
Pn40A	First Stage Notch Filter Q Value	Yes
Pn40C	Second Stage Notch Filter Frequency	Yes
Pn40D	Second Stage Notch Filter Q Value	Yes
Pn140	Model Following Control-Related Selections	Yes
Pn141	Model Following Control Gain	Yes
Pn142	Model Following Control Gain Correction	Yes
Pn143	Model Following Control Bias in the Forward Direction	Yes
Pn144	Model Following Control Bias in the Reverse Direction	Yes
Pn145	Vibration Suppression 1 Frequency A	Yes
Pn146	Vibration Suppression 1 Frequency B	Yes
Pn147	Model Following Control Speed Feedforward Compensation	Yes
Pn160	Anti-Resonance Control-Related Selections	Yes
Pn161	Anti-Resonance Frequency	Yes
Pn163	Anti-Resonance Damping Gain	Yes

Yes: The parameter is automatically set.

No: The parameter is not automatically set, but the setting is read during execution.

9.9 Custom Tuning

9.9.1 Overview

This section describes custom tuning.

9.9.2 Outline

You can use custom tuning to manually adjust the servo during operation using a speed or position reference input from the host controller. You can use it to fine-tune adjustments that were made with autotuning.

The following items are adjusted automatically.

- Gains (e.g., speed loop gain and position loop gain)
- Filters (torque reference filter and notch filters)
- Friction compensation
- Anti-resonance control

Refer to the following section for details on the parameters that are adjusted.

→ [Chap. 9.9.8 'Related Parameters' ...page 346](#)

There are two adjustment methods that you can use for custom tuning.

- **Tuning Mode 0 (Setting Servo Gains Giving Priority to Stability) or 1 (Setting Servo Gains Giving Priority to Good Response)**
These modes allow you to set stable control conditions for multiple servo gains by manipulating only one tuning level. Automatic setting of notch filters and anti-resonance control is provided if vibration is detected. Manual anti-resonance control adjustment is also possible during custom tuning.
- **Tuning Mode 2 (Setting Servo Gains Giving Priority to Position Control Applications) or 3 (Setting Servo Gains Giving Priority to Preventing Overshooting in Position Control Applications)**
Two tuning levels are manipulated to reduce positioning time even further and set multiple servo gains.
Model following control is used to reduce the positioning time. If vibration is detected, notch filters and anti-resonance control are automatically adjusted, and friction compensation is automatically set. Manual anti-resonance control adjustment and vibration suppression are also possible during custom tuning.



CAUTION

Vibration or overshooting may occur during custom tuning. To ensure safety, make sure that you can perform an emergency stop at any time.

9.9.3 Preparations

Check the following settings before you execute custom tuning.

- The test without a motor function must be disabled (Pn00C = n.□□□0).
- The tuning-less function must be disabled (Pn170 = n.□□□0).
- If speed control is used, tuning mode 0 or 1 must be set.
- The parameters must not be write prohibited.

9.9.4 Applicable Tools

The following table lists the tools that you can use to perform custom tuning and the applicable tool functions.

Tool	Function	Operating Procedure Reference
Digital Operator	Fn203	Σ-7-Series Digital Operator Operating Manual (Manual No.: SIEP S800001 33)
SigmaWin+	Tuning - Tuning	→ Chap. 9.9.5 'Operating Procedure' ...page 333

9.9.5 Operating Procedure

Use the following procedure to perform custom tuning.




WARNING

Before you execute custom tuning, check the information provided in the SigmaWin+ operating manual.

Observe the following precautions.

- Make sure that you can perform an emergency stop at any time. When custom tuning is started, several parameters will be overwritten with the recommended settings, which may greatly affect the response before and after execution. Make sure that you can perform an emergency stop at any time.
- Set the moment of inertia correctly before you execute custom tuning. If the setting greatly differs from the actual moment of inertia, vibration may occur.
- If you change the feedforward level, the new setting will not be used immediately. It will be used after positioning is completed.

1. Confirm that the moment of inertia ratio (Pn103) is set correctly.
2. Click the  Servo Drive Button in the workspace of the Main Window of the SigmaWin+.
3. Select **Tuning** in the Menu Dialog Box.
 - ➔ The Tuning Dialog Box will be displayed. Click the **Cancel** Button to cancel tuning.

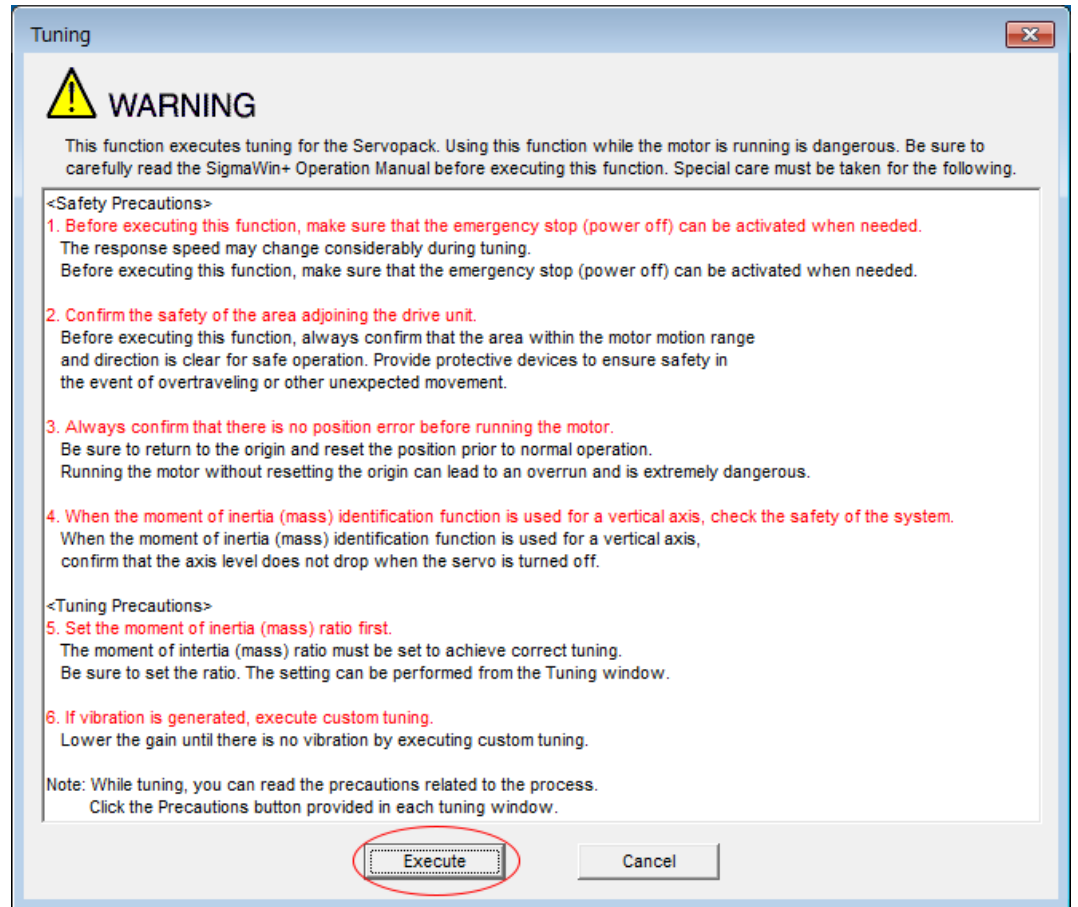
4. Click the **Execute** Button.

Fig. 257: Tuning - Warning

5. → Click the **Advanced adjustment** Button.

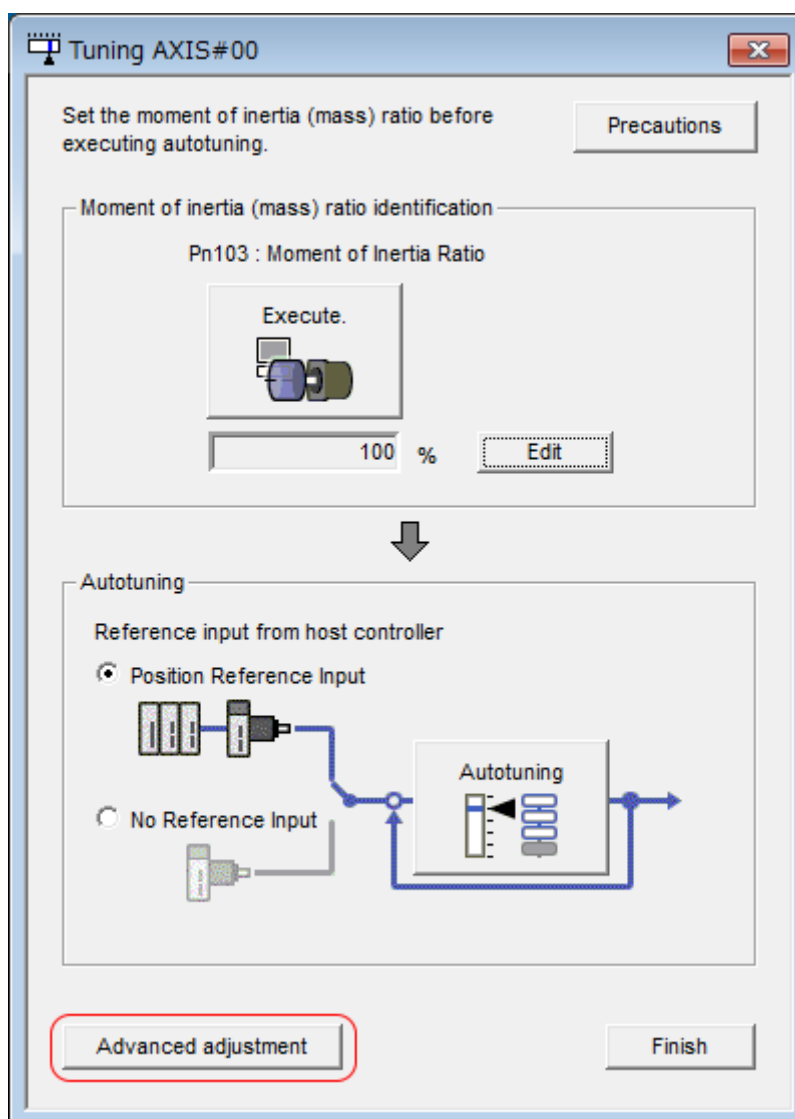


Fig. 258: Tuning AXIS#00 - Autotuning - Position Reference Input



When the following dialog box is displayed, click the **OK** Button and then confirm that the correct moment of inertia ratio is set in Pn103 (Moment of Inertia Ratio).

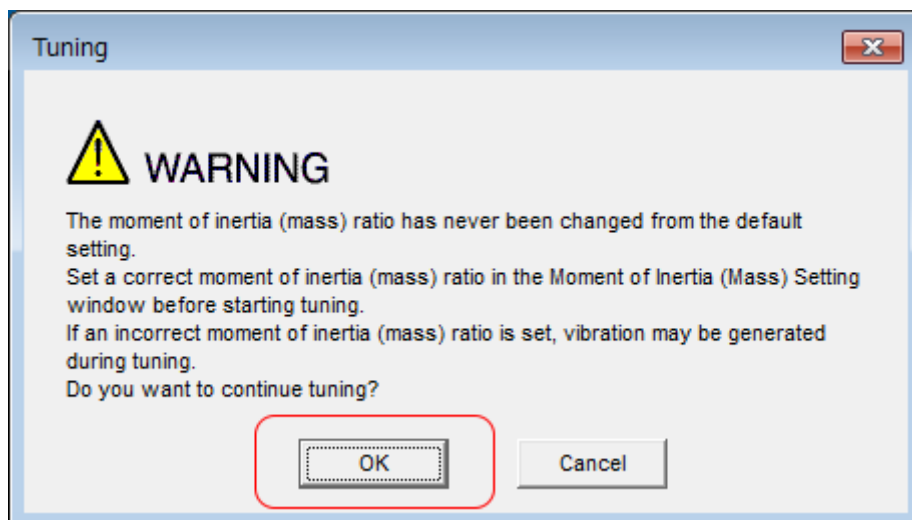


Fig. 259: Tuning - Warning - The Moment of Inertia Ratio has never been changed from the default setting

6. Click the **Custom tuning** Button.

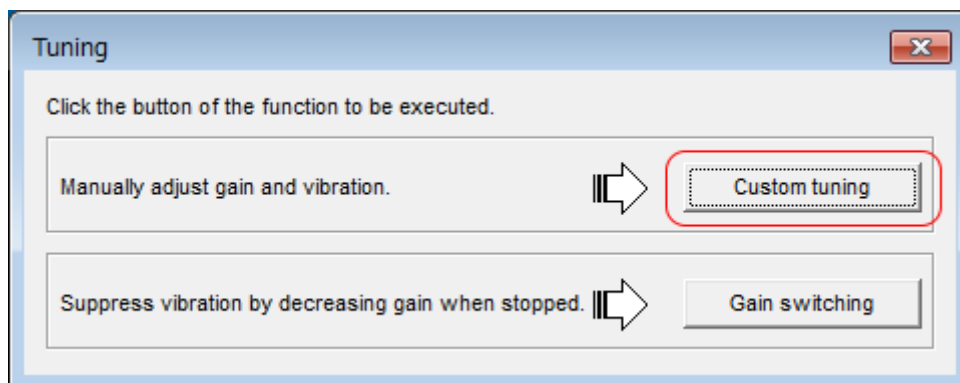


Fig. 260: Custom Tuning - Custom tuning Button

7. → Set the **Tuning mode** Box and **Mechanism selection** Box, and then click the **Next** Button.

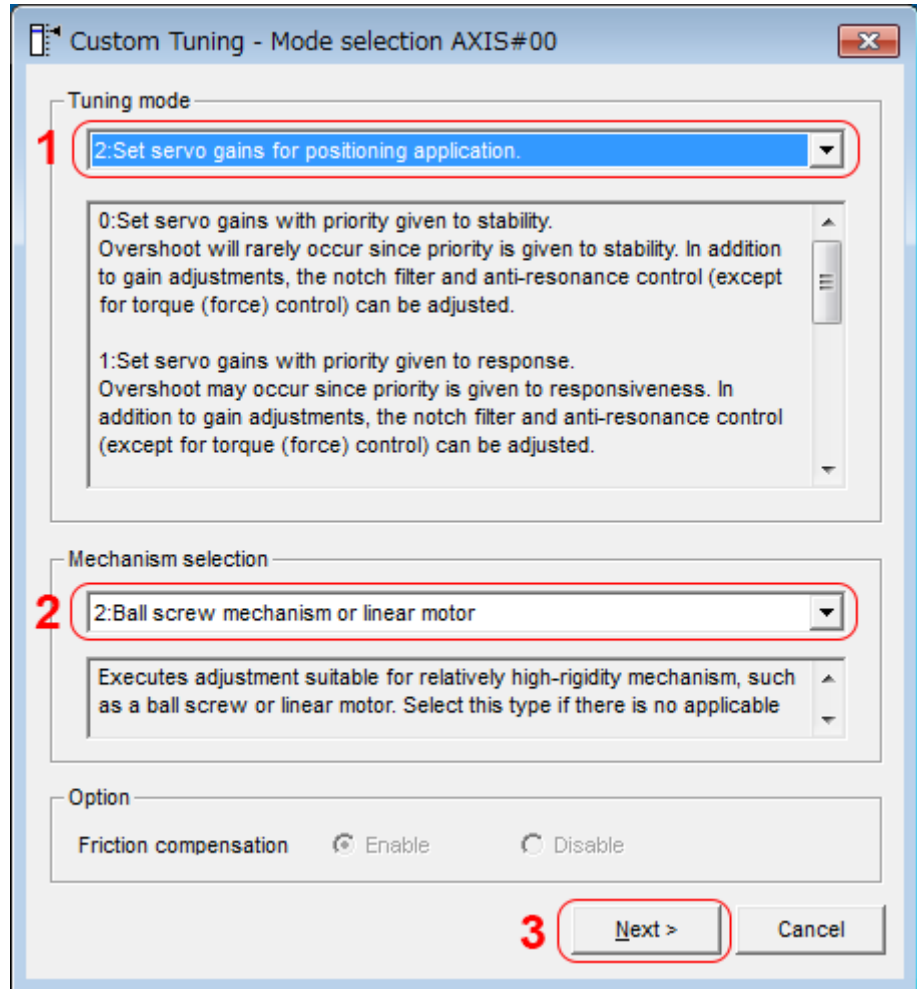


Fig. 261: Custom Tuning - Mode selection AXIS#00

➔ 1 - Tuning mode Box

- 0: Set servo gains with priority given to stability.
This setting gives priority to stability and preventing overshooting. In addition to gain adjustment, notch filters and anti-resonance control (except during torque control) are automatically adjusted.
- 1: Set servo gains with priority given to response.
Overshooting may occur because priority is given to response. In addition to gain adjustment, notch filters and anti-resonance control (except during torque control) are automatically adjusted.
- 2: Set servo gains for positioning application.
Tuning is performed for positioning applications. In addition to gain adjustment, notch filters, anti-resonance control, and vibration suppression are adjusted.
- 3: Set servo gains especially to prevent overshooting during positioning application.
Tuning is performed for positioning applications with emphasis on eliminating overshooting. In addition to gain adjustment, notch filters, anti-resonance control, and vibration suppression are adjusted.

2 - Mechanism selection Box

Select the type according to the machine element to drive.

If there is noise or if the gain does not increase, better results may be obtained by changing the rigidity type. Select the type according to the following guidelines.

- 1: Belt mechanism
Tuning is performed for a mechanism with relatively low rigidity, e.g., a belt.
- 2: Ball screw mechanism or Linear motor
Tuning is performed for a mechanism with relatively high rigidity, e.g., a ball screw or Linear Servomotor. Use this setting if there is no other appropriate setting.
- 3: Rigid body system
Tuning is performed for a mechanism with high rigidity, e.g., a rigid body system.



The tuning modes that you can select depend on the SERVO-PACK setting.

8. → If the moment of inertia ratio is not set correctly, correct the setting and then click the **Next** Button.

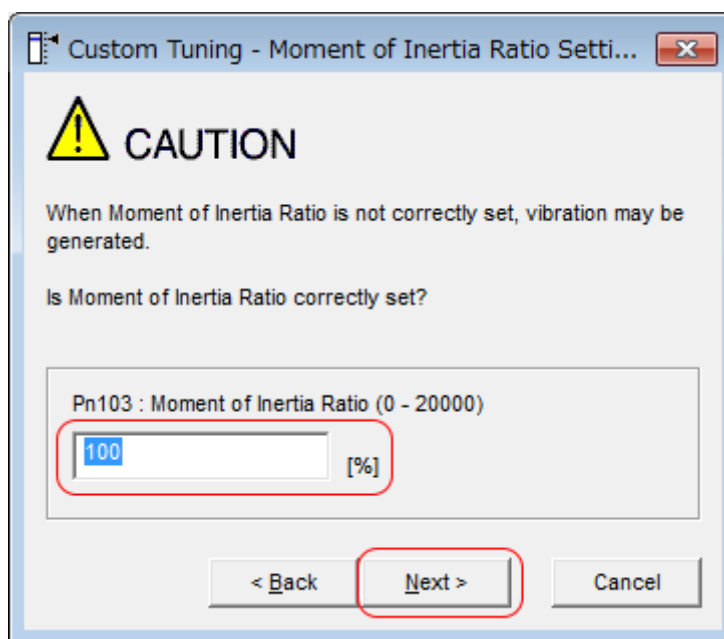


Fig. 262: Custom Tuning - Moment of Inertia Ratio Setting

9. Turn ON the servo, enter a reference from the host controller, and then click the **Start tuning** Button.

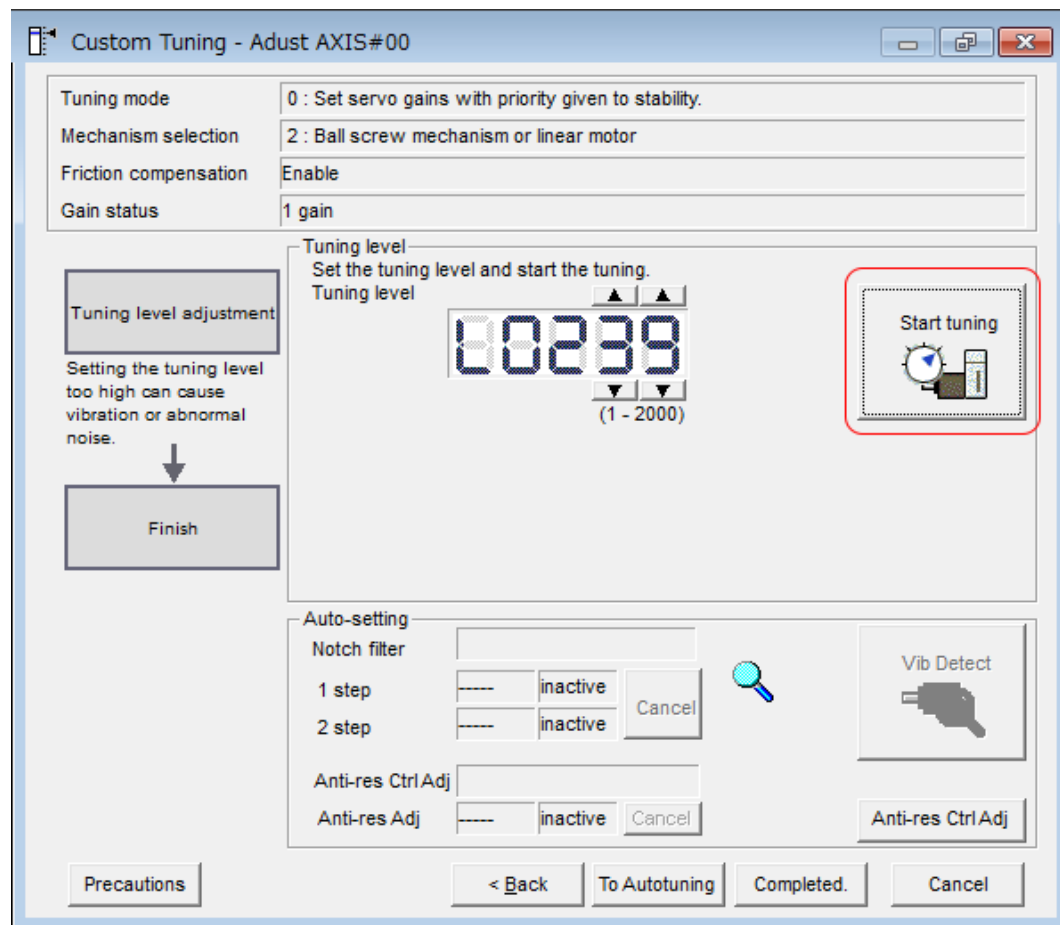


Fig. 263: Custom Tuning - Tuning Mode 0 or 1 - Start Tuning

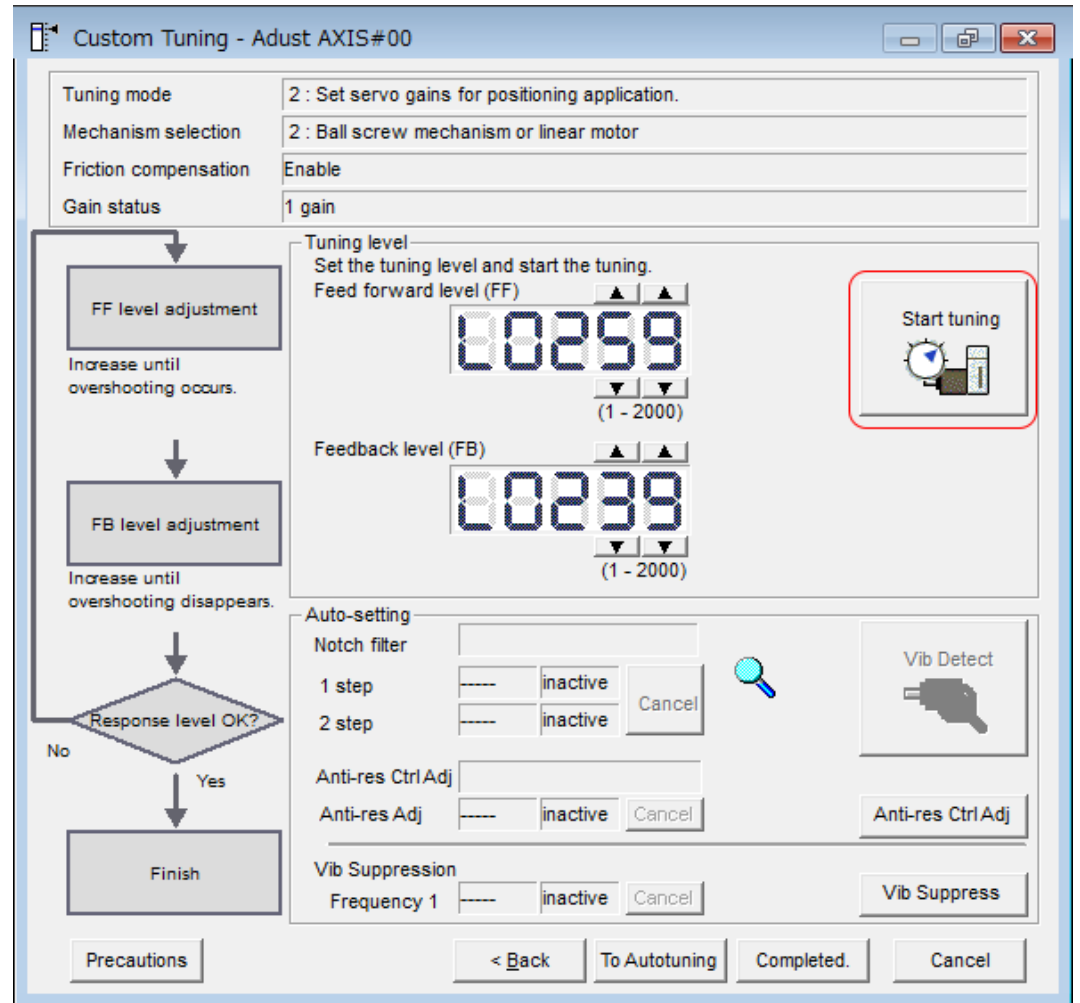


Fig. 264: Custom Tuning - Tuning Mode 2 or 3 - Start Tuning

10. Use the ▲ and ▼ Buttons to change the tuning level.

Click the **Back** Button during tuning to restore the setting to its original value. The tuning level will return to the value from before when custom tuning was started.

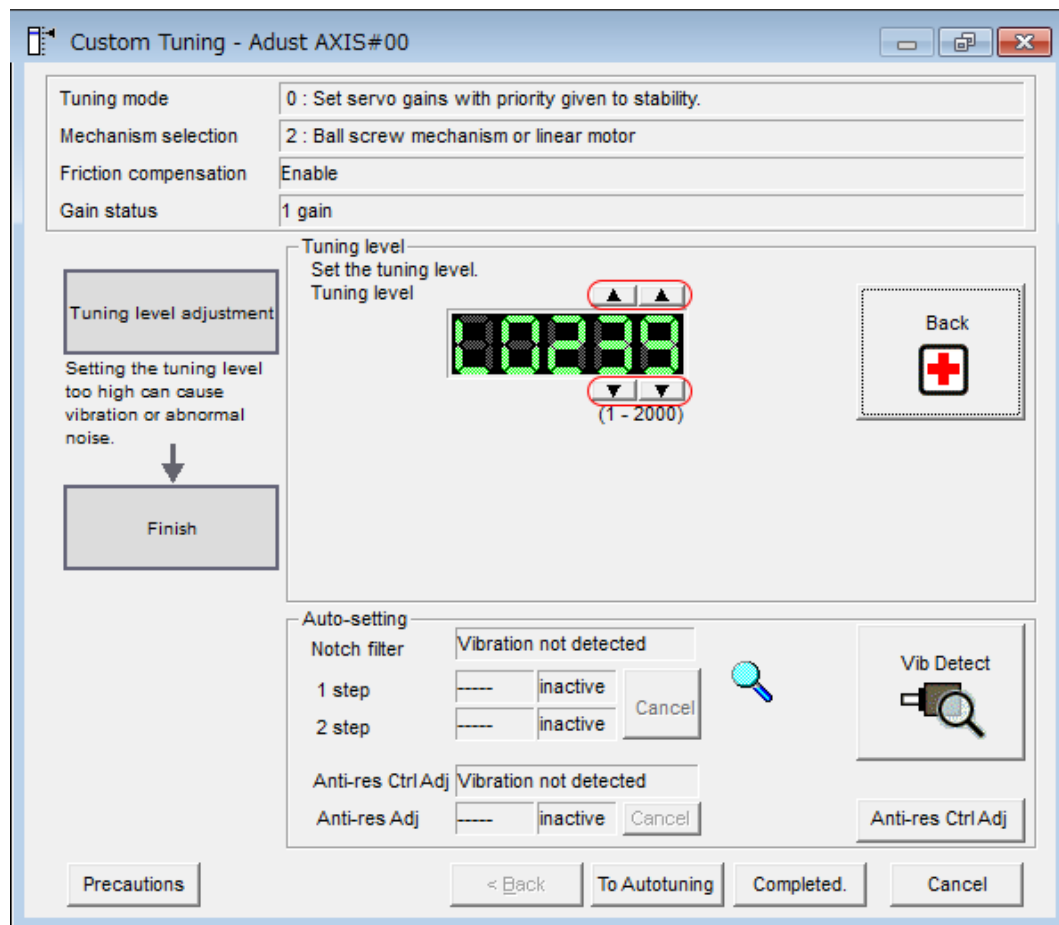


Fig. 265: Custom Tuning - Tuning Mode 0 or 1 - Changing the tuning level

➔ Tuning Mode 0 or 1

Increase the tuning level until overshooting occurs.

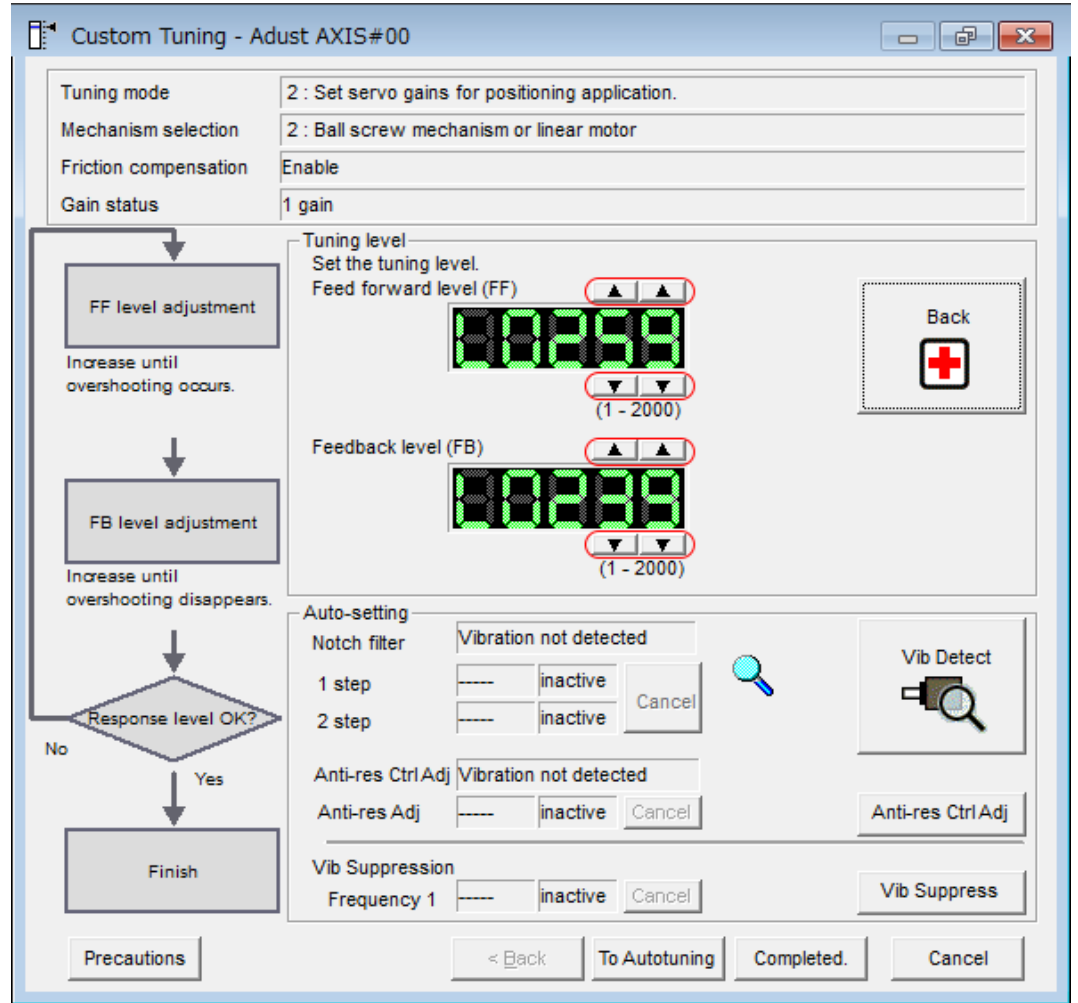


Fig. 266: Custom Tuning - Tuning Mode 2 or 3 - Changing the tuning level

Tuning Mode 2 or 3

Increase the feedforward level until overshooting occurs and then increase the feedback level until overshooting is eliminated. Repeat these changes to make the adjustment.

i *The new feedforward level will not be used until the positioning completed signal is output.*

11. You can set the functions to suppress vibration (notch filters, automatic anti-resonance control setting, anti-resonance control adjustment, and autotuning with a host reference) as required.

Refer to the following section for details.

➔ [‘Vibration Suppression Functions’ ...page 343](#)

12. When tuning has been completed, click the **Completed** Button.

The values that were changed will be saved in the SERVOPACK and you will return to the Tuning Dialog Box.

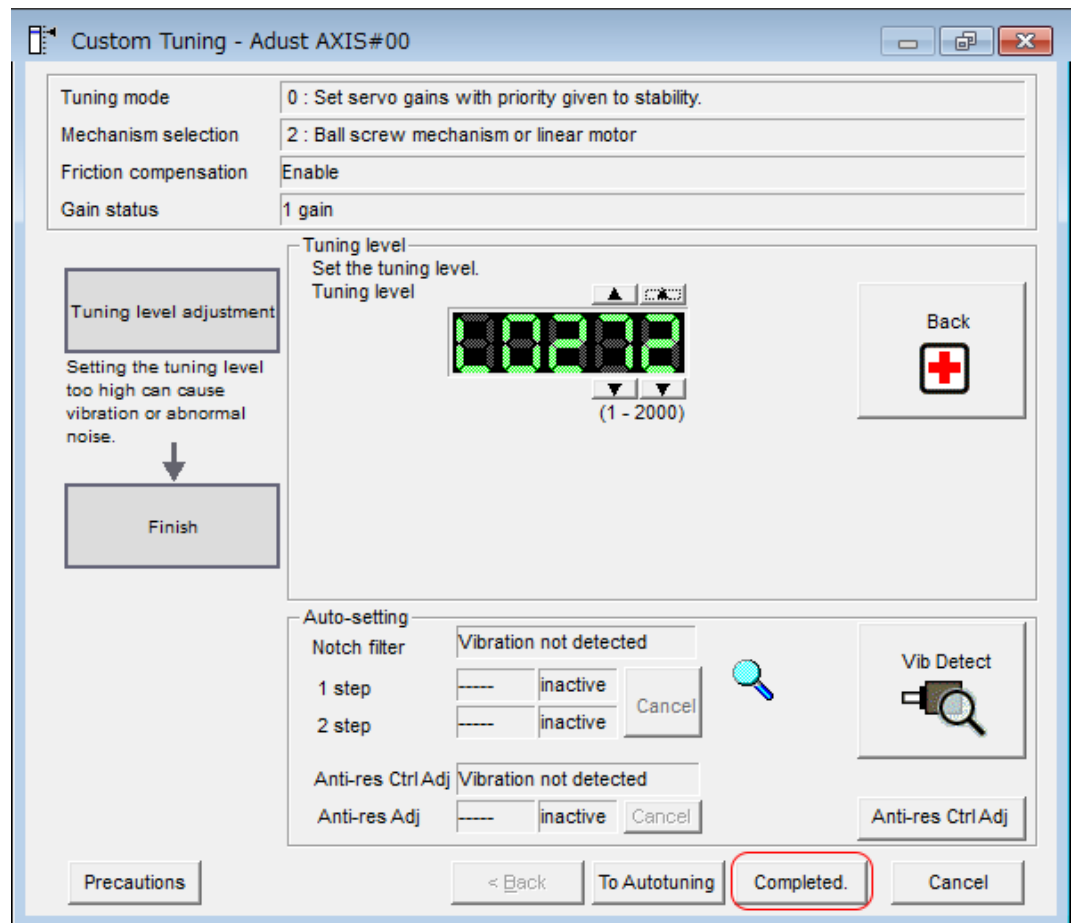


Fig. 267: Custom Tuning - Completed - Return to Autotuning

This concludes the procedure to set up custom tuning.

Vibration Suppression Functions

- Notch Filters and Automatic Anti-resonance Control Setting

If the vibration frequency that occurs when you increase the servo gains is at 1,000 Hz or higher, notch filters are effective to suppress vibration. If the vibration is between 100 Hz and 1,000 Hz, anti-resonance control is effective.
- Automatic Setting

To set vibration suppression automatically, use the parameters to enable notch filters and automatic anti-resonance control setting.

The notch filter frequency (stage 1 or 2) or anti-resonance control frequency that is effective for the vibration that was detected during tuning will be automatically set.

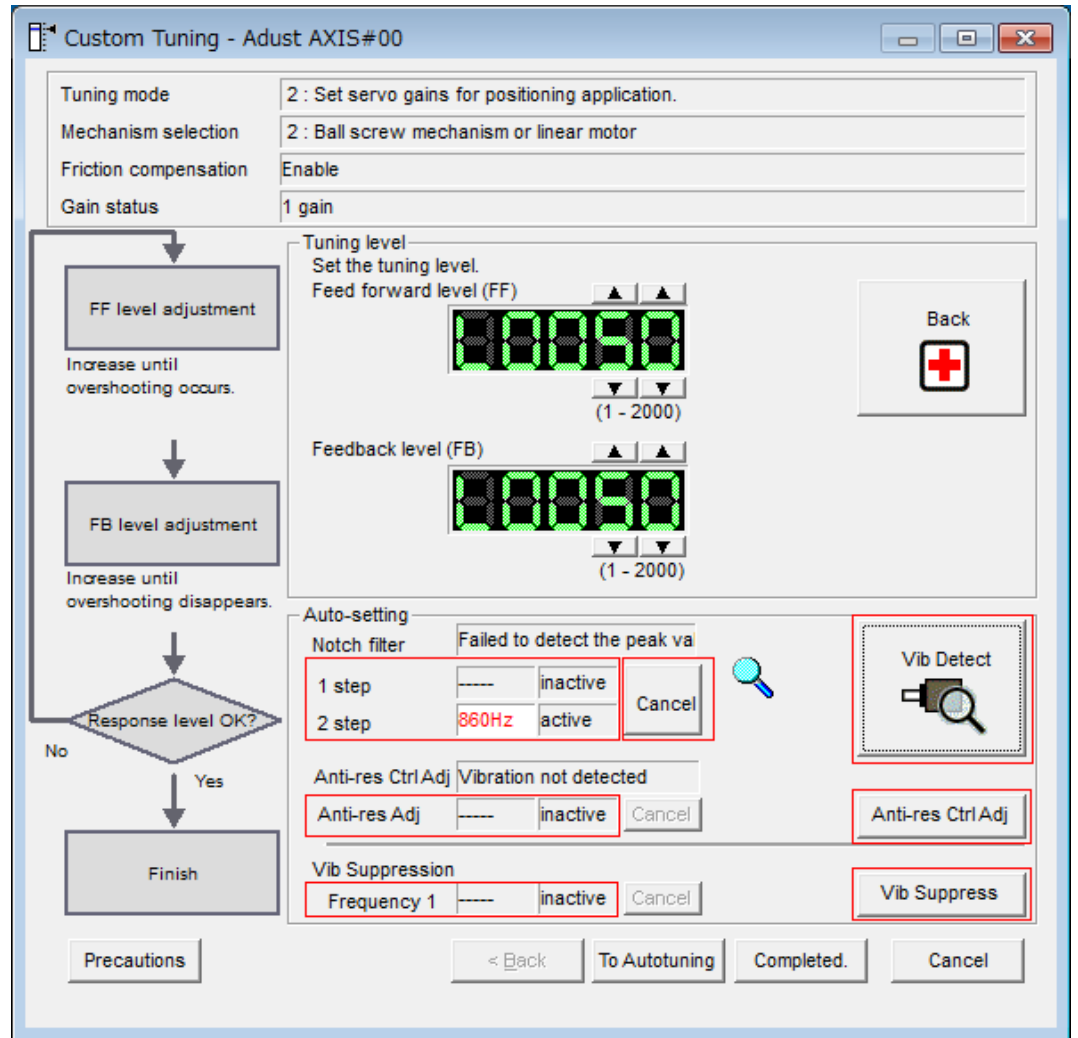


Fig. 268: Custom Tuning - Automatic Setting

Auto-setting Cancel Buttons

The automatically set notch filter frequencies or the anti-resonance control frequencies may not always suppress vibration. Click the **Cancel** Button to reset the notch filter frequencies or the anti-resonance control frequencies to the values from just before these frequencies were set automatically.

When they are reset, vibration detection will start again.

Vib Detect Button

While the notch filter or automatic anti-resonance control setting function is enabled, you can click the **Vib Detect** Button to manually detect vibration. When you click the **Vib Detect** Button, the SERVOPACK will detect vibration at that time, and set the notch filter frequency (stage 1 or 2) or anti-resonance control frequency that is effective for the detected vibration. You can also perform manual vibration detection even when the SERVOPACK does not detect vibration.

Anti-res Ctrl Adj Button

You can use the **Anti-res Ctrl Adj** Button to execute the anti-resonance control function if fine-tuning is required. Refer to the following section.

➔ [Chap. 9.10.1 'Anti-Resonance Control Adjustment' ...page 347](#)

Vib Suppress Button

Click the **Vib Suppress** Button to suppress low and transient vibration (oscillation) of approximately 1 Hz to 100 Hz that occurs during positioning. Refer to the following section.

➔ [Chap. 9.11.1 'Vibration Suppression' ...page 355](#)

■ Autotuning with a Host Reference

You can perform autotuning with a host reference. Refer to the following section for details.

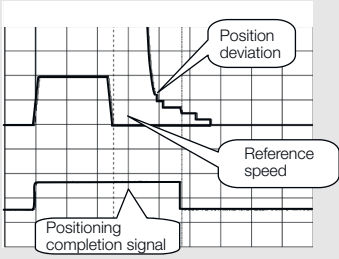
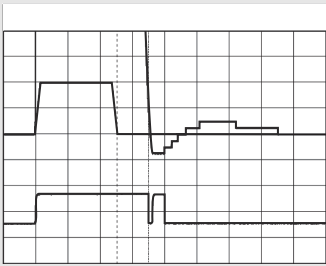
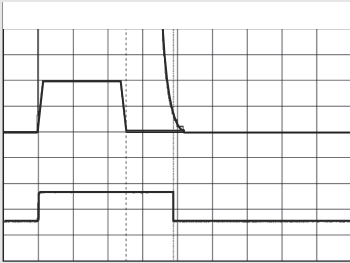
➔ [Chap. 9.8.1 'Autotuning with a Host Reference' ...page 322](#)

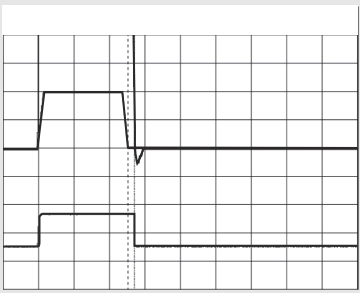
9.9.6 Automatically Adjusted Function Settings

You cannot use vibration suppression functions at the same time. Other automatic function settings are the same as for autotuning without a host reference. Refer to the following section.

➔ [Chap. 9.7.7 'Automatically Adjusted Function Settings' ...page 318](#)

9.9.7 Tuning Example for Tuning Mode 2 or 3

Step	Measurement Display Examples	Operation
1	 <p>The graph shows a step change in the reference speed (bottom trace). The top trace shows the resulting speed and position. A vertical dashed line marks the start of the positioning phase. The 'Positioning completion signal' is shown as a pulse at the end of the positioning phase. 'Position deviation' is indicated as the difference between the actual position and the target position at the end of the positioning phase.</p>	<p>The positioning time is measured after the moment of inertia ratio (Pn103) is set correctly.</p> <p>Tuning is completed if the specifications are met.</p> <p>The tuning results are saved in the SERVOPACK.</p>
2	 <p>The graph shows a step change in the reference speed. The top trace shows the resulting speed and position. The positioning time is shorter than in step 1, but there is significant overshoot in the position trace.</p>	<p>The positioning time will be reduced if the feedforward level is increased.</p> <p>Tuning is completed if the specifications are met. The tuning results are saved in the SERVOPACK.</p> <p>If overshooting occurs before the specifications are met, proceed to step 3.</p>
3	 <p>The graph shows a step change in the reference speed. The top trace shows the resulting speed and position. The positioning time is further reduced, and the overshoot is significantly reduced compared to step 2.</p>	<p>Overshooting will be reduced if the feedback level is increased.</p> <p>If the overshooting is eliminated, proceed to step 4.</p>

Step	Measurement Display Examples	Operation
4		<p>The graph shows overshooting that occurred when the feedforward level was increased even more after step 3. In this state, overshooting occurs, but the positioning settling time is shorter. Tuning is completed if the specifications are met.</p> <p>The tuning results are saved in the SERVOPACK. If overshooting occurs before the specifications are met, repeat steps 3 and 4.</p> <p>If vibration occurs before the overshooting is eliminated, the vibration is suppressed with the notch filters and anti-resonance control.</p>
5	-	The tuning results are saved in the SERVOPACK.

9.9.8 Related Parameters

The following parameters are automatically adjusted or used as reference when you execute custom tuning.

Do not change the settings while custom tuning is being executed.

Parameter	Name	Automatic Changes
Pn100	Speed Loop Gain	Yes
Pn101	Speed Loop Integral Time Constant	Yes
Pn102	Position Loop Gain	Yes
Pn103	Moment of Inertia Ratio	No
Pn121	Friction Compensation Gain	Yes
Pn123	Friction Compensation Coefficient	Yes
Pn124	Friction Compensation Frequency Correction	No
Pn125	Friction Compensation Gain Correction	Yes
Pn401	First Stage First Torque Reference Filter Time Constant	Yes
Pn408	Torque-Related Function Selections	Yes
Pn409	First Stage Notch Filter Frequency	Yes
Pn40A	First Stage Notch Filter Q Value	Yes
Pn40C	Second Stage Notch Filter Frequency	Yes
Pn40D	Second Stage Notch Filter Q Value	Yes
Pn140	Model Following Control-Related Selections	Yes
Pn141	Model Following Control Gain	Yes
Pn142	Model Following Control Gain Correction	Yes
Pn143	Model Following Control Bias in the Forward Direction	Yes
Pn144	Model Following Control Bias in the Reverse Direction	Yes
Pn145	Vibration Suppression 1 Frequency A	No

Parameter	Name	Automatic Changes
Pn146	Vibration Suppression 1 Frequency B	No
Pn147	Model Following Control Speed Feedforward Compensation	Yes
Pn160	Anti-Resonance Control-Related Selections	Yes
Pn161	Anti-Resonance Frequency	Yes
Pn163	Anti-Resonance Damping Gain	Yes

Yes: The parameter is automatically set.

No: The parameter is not automatically set, but the setting is read during execution.

9.10 Anti-Resonance Control Adjustment

9.10.1 Overview

This section describes anti-resonance control.

9.10.2 Outline

Anti-resonance control increases the effectiveness of vibration suppression after custom tuning.

Anti-resonance control is effective for suppression of continuous vibration frequencies from 100 to 1,000 Hz that occur when the control gain is increased. Vibration can be eliminated by setting vibration frequencies through automatic detection or by manually setting them to adjust the damping gain. Input an operation reference and execute this anti-resonance control adjustment when there is vibration.

Anti-resonance control is automatically set by autotuning without a host reference or autotuning with a host reference. Use anti-resonance control adjustment only if fine-tuning is required or readjustment is required as a result of a failure to detect vibration.

Perform custom tuning if required to increase the response after performing anti-resonance control adjustment. If the control gain is increased, e.g., when custom tuning is performed, vibration may occur again. If that occurs, perform anti-resonance control adjustment again to fine-tune the parameters.



CAUTION

- Related parameters will be set automatically when anti-resonance control adjustment is executed. This may greatly affect the response before and after execution. Make sure that you can perform an emergency stop at any time.
- Before you execute anti-resonance control adjustment, set the correct moment of inertia ratio (Pn103). If the setting greatly differs from the actual moment of inertia ratio, normal control of the machine may not be possible, and vibration may occur.



- *Anti-resonance control adjustment detects vibration frequencies between 100 Hz and 1,000 Hz. If the vibration frequency is not within this range, use custom tuning with tuning mode 2 selected to automatically set a notch filter or use vibration suppression.*
- *Vibration reduction can be made more effective by increasing the anti-resonance damping gain (Pn163), but the vibration may become larger if the damping gain is too high. Increase the damping gain by approximately 0% to 200% in 10% increments while checking the effect on vibration. If vibration reduction is still insufficient at a gain of 200%, cancel the setting, and lower the control gain by using a different method, such as custom tuning.*

9.10.3 Preparations

Check the following settings before you execute anti-resonance control adjustment.

- The tuning-less function must be disabled (Pn170 = n.□□□0).
- The test without a motor function must be disabled (Pn00C = n.□□□0).
- The control method must not be set to torque control.
- The parameters must not be write prohibited.

9.10.4 Applicable Tools

The following table lists the tools that you can use to perform anti-resonance control adjustment and the applicable tool functions.

Tool	Function	Operating Procedure Reference
Digital Operator	Fn204	Σ-7-Series Digital Operator Operating Manual (Manual No.: SIEP S800001 33)
SigmaWin+	Tuning - Tuning	↪ Chap. 9.10.5 'Operating Procedure' ...page 348

9.10.5 Operating Procedure

To execute anti-resonance control adjustment, an operation reference is input, and the adjustment is executed while vibration is occurring.

The following methods can be used to execute anti-resonance control adjustment.

- To automatically detect the vibration frequency
- To manually set the vibration frequency


Use the following procedure to perform anti-resonance control.

**CAUTION**

Before you execute anti-resonance control adjustment, check the information provided in the SigmaWin+ operating manual.

Observe the following precautions.

- Make sure that you can perform an emergency stop at any time.
Parameters will be set automatically when anti-resonance control adjustment is executed. This may greatly affect the response before and after execution. Make sure that you can perform an emergency stop (to turn OFF the power supply) at any time.
- Set the moment of inertia correctly before you execute anti-resonance control adjustment.
If the setting greatly differs from the actual moment of inertia, effective vibration reduction may not be possible.
- If you have already performed anti-resonance control adjustment and then you change the frequency, the current anti-resonance control effect may be lost. Caution is particularly required when automatically detecting the vibration frequency.
- If effective vibration reduction is not achieved even after you execute anti-resonance control adjustment, cancel the function and lower the control gain by using a different method, such as custom tuning.
- Perform custom tuning separately if required to increase the response after performing anti-resonance control adjustment.
If the servo gain is increased, e.g., when custom tuning is performed, vibration may occur again.
If that occurs, perform anti-resonance control adjustment again to fine-tune the parameters.

1.  Perform steps 1 to 8 of the procedure for custom tuning. Refer to the following section for details.

➔ [Chap. 9.9.5 'Operating Procedure' ...page 333](#)

2. Click the **Anti-res Ctrl Adj** Button.

The rest of the procedure depends on whether you know the vibration frequency.

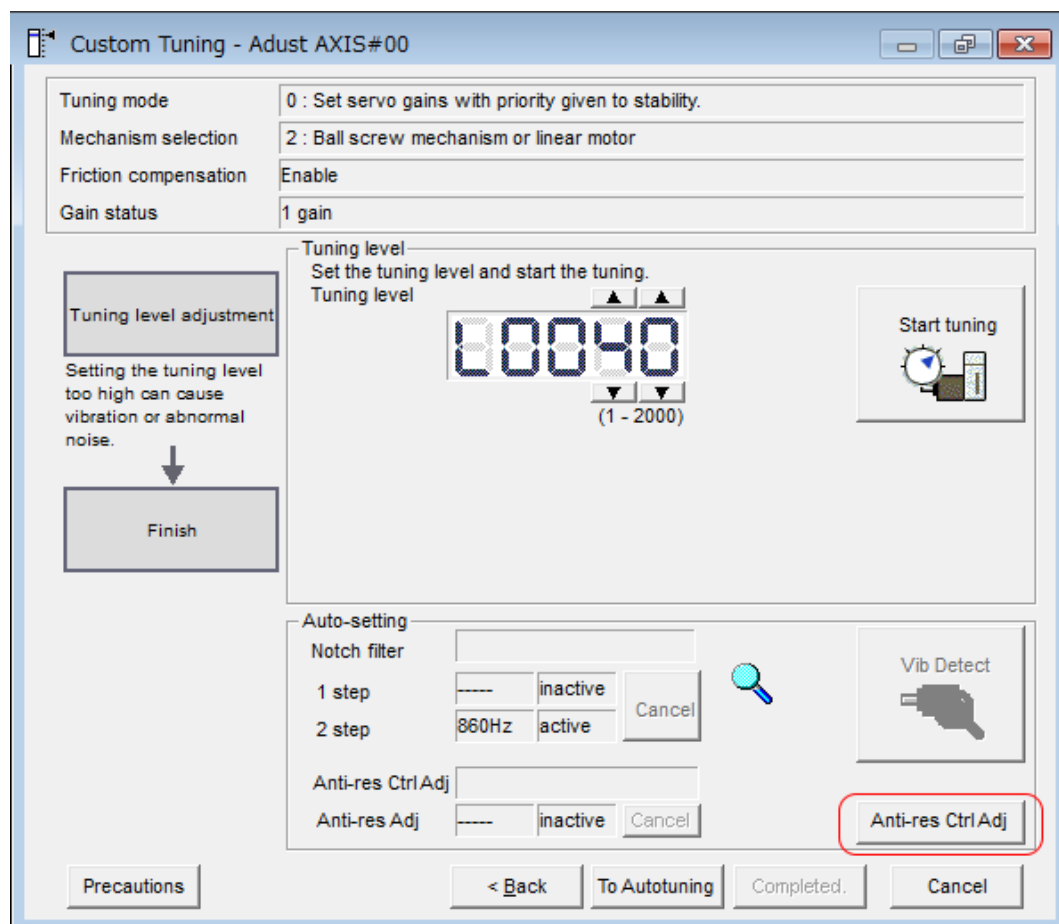


Fig. 269: Custom Tuning - Adjust AXIS#00 - Anti-res Ctrl Adj

3. → If you do not know the vibration frequency, click the **Auto Detect** Button. If you know the vibration frequency, click the **Manual Set** Button.

To Automatically Detect the Vibration Frequency

The frequency will be set.

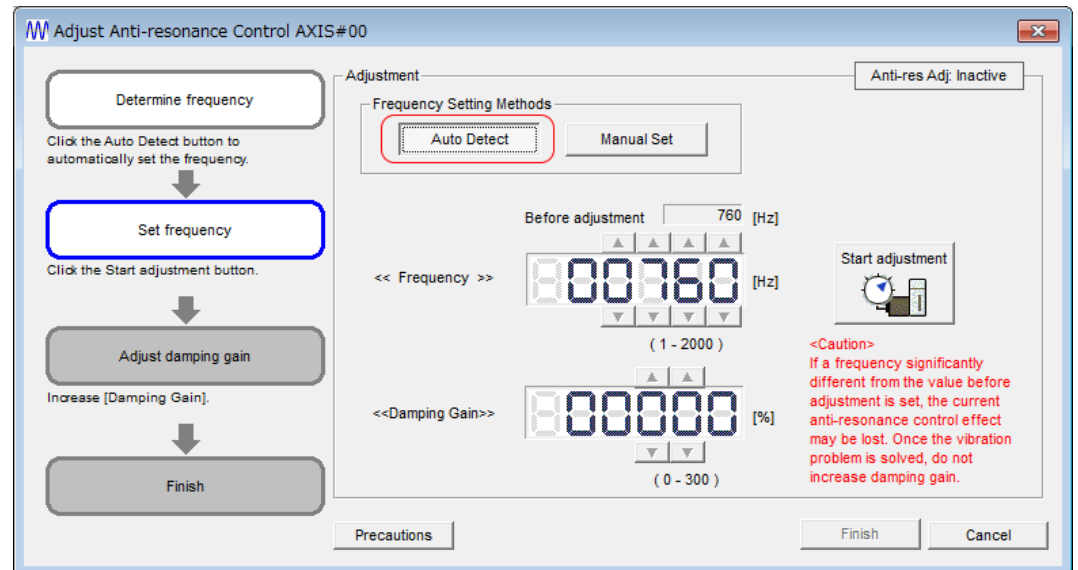


Fig. 270: Adjust Anti-resonance Control AXIS#00 - Auto Detect

→ To Manually Set the Vibration Frequency

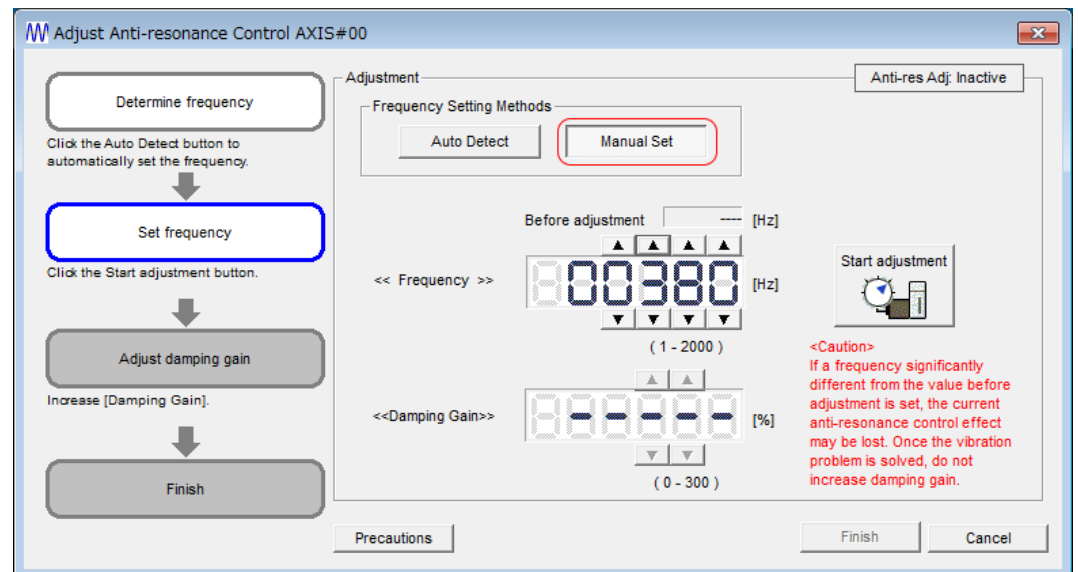


Fig. 271: Adjust Anti-resonance Control AXIS#00 - Manual Set

4. → Click the **Start adjustment** Button.

5. Use the ▲ and ▼ Buttons in the Adjustment Area to change the settings.
 Click the **Reset** Button during tuning to restore the setting to its original value. The tuning level will return to the value from before when custom tuning was started.
 To Automatically Detect the Vibration Frequency
 Change the setting of the damping gain.

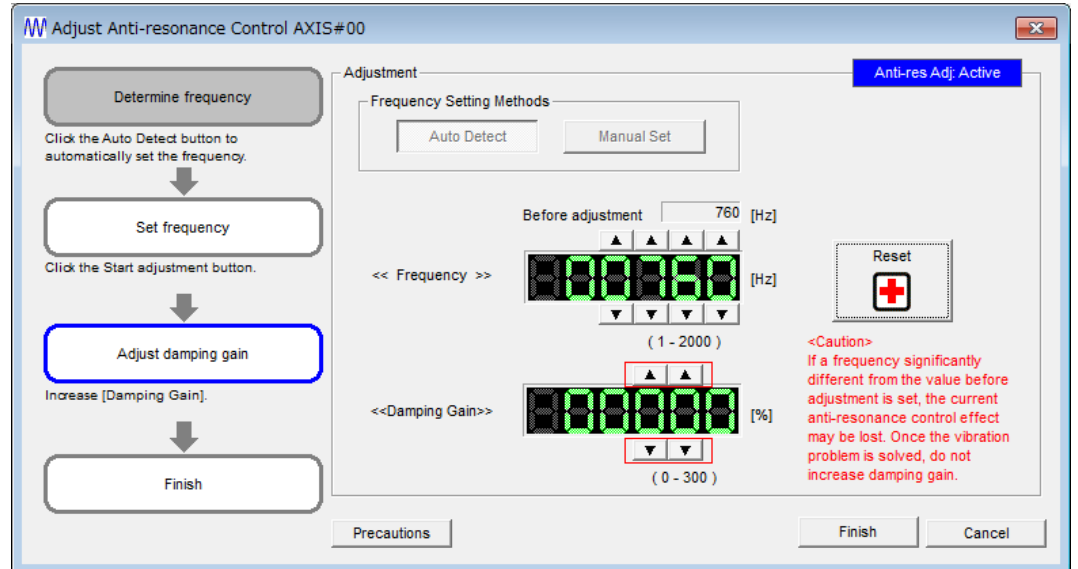


Fig. 272: Adjust Anti-resonance Control AXIS#00 - Change Damping Gain

- ➔ To Manually Set the Vibration Frequency
 Change the settings of the frequency and damping gain.

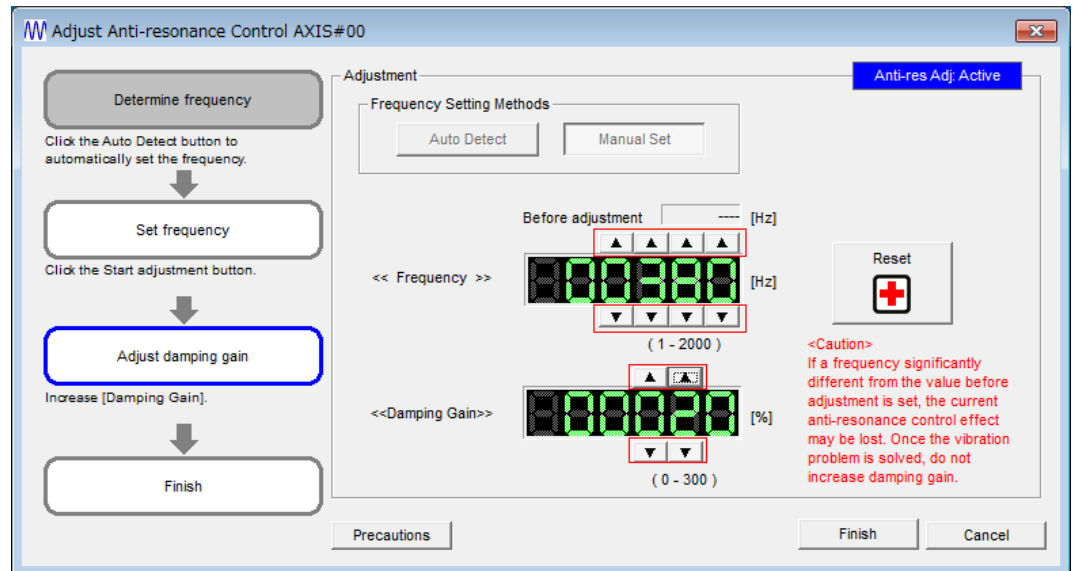


Fig. 273: Adjust Anti-resonance Control AXIS#00 - Change Frequency and Damping Gain

6. → When the adjustment has been completed, click the **Finish** Button.

The values that were changed will be saved in the SERVOPACK and you will return to the Tuning Dialog Box.

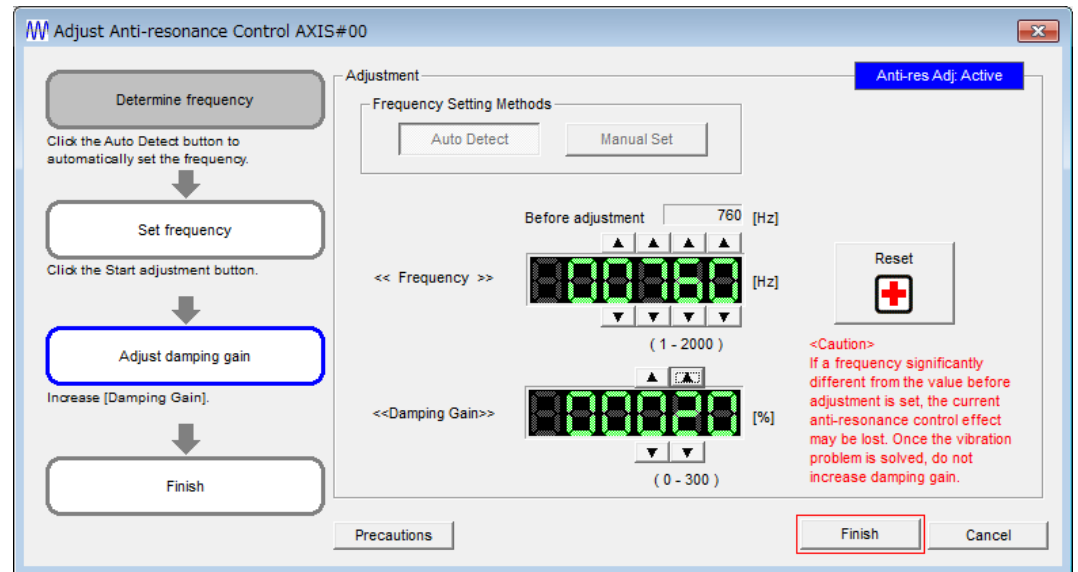


Fig. 274: Adjust Anti-resonance Control AXIS#00 - Finish

This concludes the procedure to set up anti-resonance control.

9.10.6 Related Parameters

The following parameters are automatically adjusted or used as reference when you execute anti-resonance control adjustment.

Do not change the settings while anti-resonance control adjustment is being executed.

Parameter	Name	Automatic Changes
Pn160	Anti-Resonance Control-Related Selections	Yes
Pn161	Anti-Resonance Frequency	Yes
Pn162	Anti-Resonance Gain Correction	No
Pn163	Anti-Resonance Damping Gain	Yes
Pn164	Anti-Resonance Filter Time Constant 1 Correction	No
Pn165	Anti-Resonance Filter Time Constant 2 Correction	No

Yes: The parameter is automatically set.

No: The parameter is not automatically set, but the setting is read during execution.

9.10.7 Suppressing Different Vibration Frequencies with Anti-resonance Control

When you use anti-resonance control and increase the control gain, for some mechanism, vibration can occur at a higher frequency than the frequency for which vibration was suppressed. If this occurs, you can suppress vibration for more than one frequency by adjusting Pn166 (Anti-Resonance Damping Gain 2).



Guidelines for Vibration That Can Be Suppressed

Anti-resonance frequency (Pn161): f_a [Hz], Another vibration frequency that occurs when the control gain is increased: f_b [Hz]

- Vibration frequencies: 100 Hz to 1,000 Hz
- Range of different vibration frequencies: $1 < (f_b/f_a) \leq 3$ to 4

Required Parameter Settings

The following parameter settings are required to use anti-resonance control for more than one vibration frequency.

Parameter	Meaning	When Enabled	Classification
Pn160	n.□□□0 (default setting)	After restart	Setup
	n.□□□1		

Anti-Resonance Frequency

	Setting Range	Setting Unit	Default Setting	When Enabled	Classification
Pn161	10 to 20,000	0.1 Hz	1000	Immediately	Tuning

(applies to Speed Control, Position Control and Torque Control)

Anti-Resonance Gain Correction

	Setting Range	Setting Unit	Default Setting	When Enabled	Classification
Pn162	1 to 1,000	1%	100	Immediately	Tuning

(applies to Speed Control, Position Control and Torque Control)

Anti-Resonance Damping Gain

	Setting Range	Setting Unit	Default Setting	When Enabled	Classification
Pn163	0 to 300	1%	0	Immediately	Tuning

(applies to Speed Control, Position Control and Torque Control)

Anti-Resonance Filter Time Constant 1 Correction

	Setting Range	Setting Unit	Default Setting	When Enabled	Classification
Pn164	-1,000 to 1,000	0.01 ms	0	Immediately	Tuning

(applies to Speed Control, Position Control and Torque Control)

Anti-Resonance Filter Time Constant 2 Correction

	Setting Range	Setting Unit	Default Setting	When Enabled	Classification
Pn165	-1,000 to 1,000	0.01 ms	0	Immediately	Tuning

(applies to Speed Control, Position Control and Torque Control)

Anti-Resonance Damping Gain 2

	Setting Range	Setting Unit	Default Setting	When Enabled	Classification
Pn166	0 to 1,000	1%	0	Immediately	Tuning

(applies to Speed Control, Position Control and Torque Control)

Adjustment Procedure for Suppressing Different Vibration Frequencies with Anti-resonance Control

Use the following procedure to make adjustments to suppress different vibration frequencies with anti-resonance control.

Step	Operation
1	Use the gain adjustment and anti-resonance control. Refer to the following section for details. ↪ Chap. 9.10.5 'Operating Procedure' ...page 348
2	If there is vibration at a higher frequency than the vibration suppressed with anti-resonance control in step 1, adjust Pn166 (Anti-Resonance Damping Gain 2).
3	Adjust Pn166 (Anti-Resonance Damping Gain 2) while checking to see if vibration reduction is effective. To adjust Pn166 (Anti-Resonance Damping Gain 2), increase the setting by 10% at a time starting from the value that resulted in Pn163 (Anti-Resonance Damping Gain) from the adjustment in step 1.
4	If the vibration disappears, the adjustment is completed. However, if the vibration does not disappear even when you adjust Pn166 (Anti-Resonance Damping Gain 2), reduce the tuning level or feedback level until vibration does not occur.

9.11 Vibration Suppression**9.11.1 Overview**

This section describes vibration suppression.

9.11.2 Outline

You can use vibration suppression to suppress transient vibration at a low frequency from 1 Hz to 100 Hz, which is generated mainly when the machine vibrates during positioning. This is effective for vibration frequencies for which notch filters and anti-resonance control adjustment are not effective.

Vibration suppression is automatically set by autotuning without a host reference or autotuning with a host reference. Use vibration suppression only if fine-tuning is required or readjustment is required as a result of a failure to detect vibration. To execute vibration suppression, input an operation reference and execute the function when there is vibration.

Perform custom tuning if required to increase the response after performing vibration suppression.



CAUTION

- Related parameters will be set automatically when vibration suppression is executed. This may greatly affect the response before and after execution. Make sure that you can perform an emergency stop at any time.
- Before you execute vibration suppression, set the correct moment of inertia ratio (Pn103) with autotuning without a host reference or another method. If the setting greatly differs from the actual moment of inertia ratio, normal control of the machine may not be possible, and vibration may occur.



- *Vibration suppression detects vibration frequencies between 1 Hz and 100 Hz.*
- *Frequency detection will not be performed if there is no vibration in the position deviation or if the vibration frequency is outside the range of detectable frequencies. If that is a problem, use a device such as a displacement meter or vibration sensor to measure the vibration frequency.*
- *If an automatically detected vibration frequency is not suppressed, the actual frequency and the detected frequency may be different. Fine-tune the detected frequency if necessary.*

Items That Influence Performance

If continuous vibration occurs while the Servomotor is stopping, vibration suppression cannot be used to suppress the vibration effectively. In this case, use anti-resonance control adjustment or custom tuning.

Detection of Vibration Frequencies

Frequency detection may not be possible if vibration does not appear in the position deviation or the vibration that results from the position deviation is too small. You can adjust the detection sensitivity by changing the setting of the residual vibration detection width (Pn560), which is set as a percentage of the positioning completed width (Pn522). Perform the detection of vibration frequencies again after adjusting the setting of Pn560.

Residual Vibration Detection Width

	Setting Range	Setting Unit	Default Setting	When Enabled	Classification
Pn560	1 to 3,000	0.1%	400	Immediately	Setup

(applies to Position Control)



As a guideline, change the setting 10% at a time. If the setting of this parameter is lowered, the detection sensitivity will be increased. Vibration may not be detected accurately if the setting is too small.



The vibration frequencies that are automatically detected may vary somewhat with each positioning operation. Perform positioning several times and make adjustments while checking the effect of vibration suppression.


9.11.3 Preparations

Check the following settings before you execute vibration suppression.

- Position control must be used.
- The tuning-less function must be disabled (Pn170 = n.□□□0).
- The test without a motor function must be disabled (Pn00C = n.□□□0).
- The parameters must not be write prohibited.


9.11.4 Applicable Tools

The following table lists the tools that you can use to perform vibration suppression and the applicable tool functions.

Tool	Function	Operating Procedure Reference
Digital Operator	Fn205	 Σ -7-Series Digital Operator Operating Manual (Manual No.: SIEP S800001 33)
SigmaWin+	Tuning - Tuning	↪ Chap. 9.11.5 'Operating Procedure' ...page 357

9.11.5 Operating Procedure

Use the following procedure to perform vibration suppression.

1.  Perform steps 1 to 8 of the procedure for custom tuning. Refer to the following section for details.

[↪ Chap. 9.9.5 'Operating Procedure' ...page 333](#)

2. Click the **Vib Suppress** Button.

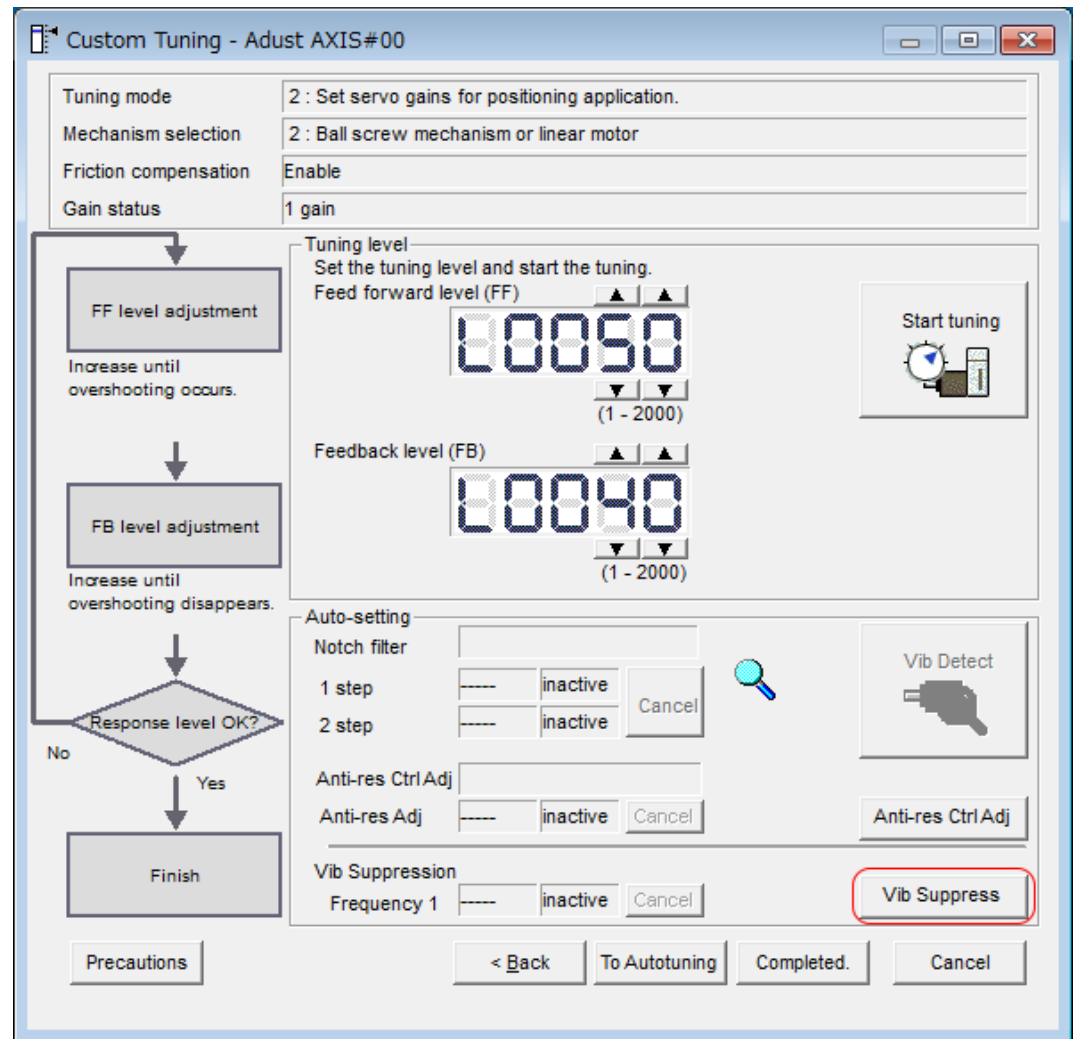


Fig. 275: Custom Tuning - Adjust AXIS#00 - Vib Suppress

3. Click the Import Button or click ▲ and ▼ Button to manually adjust the set frequency.

When you click the **Import** Button, the residual vibration frequency in the Servomotor is read as the set frequency. (The frequency can be read only when the residual vibration frequency is between 1.0 and 100.0.)



Frequency detection will not be performed if there is no vibration or if the vibration frequency is outside the range of detectable frequencies. If a vibration frequency is not detected, provide a means of measuring the vibration frequency.

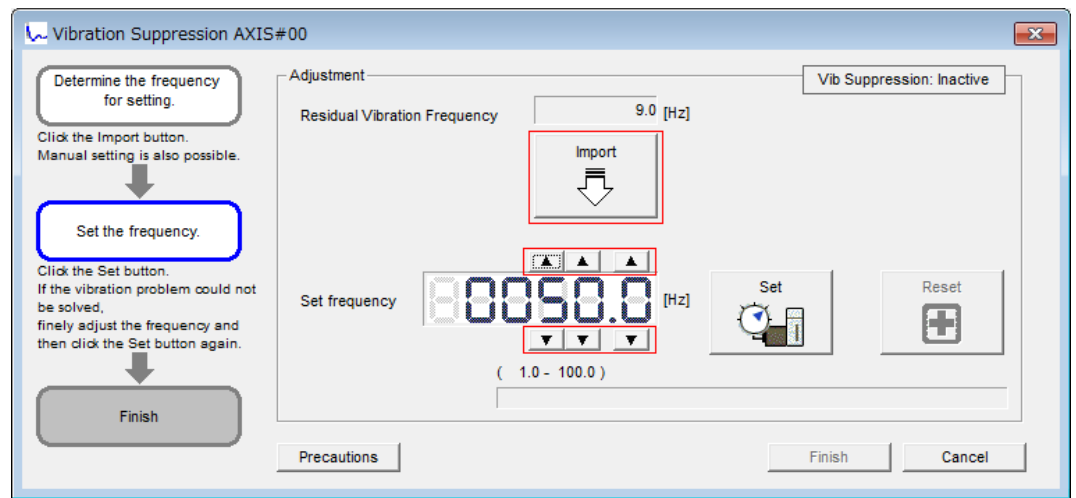


Fig. 276: Vibration Suppression AXIS#00 - Manual Adjustment of the Frequency

4. Click the **Set** Button.



No settings related to vibration suppression are changed during operation.

If the Servomotor does not stop within approximately 10 seconds after changing the setting, an update timeout will occur. The setting will be automatically returned to the previous value.

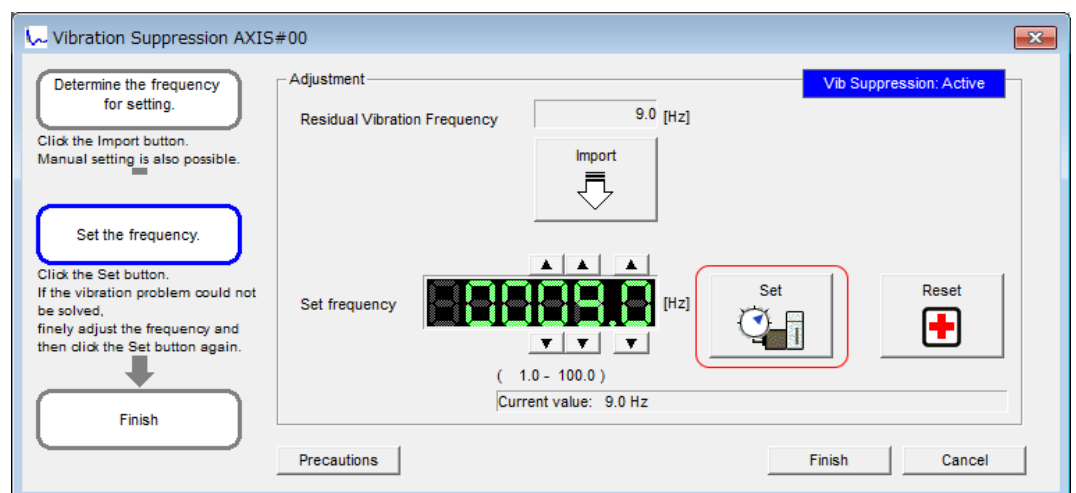


Fig. 277: Vibration Suppression AXIS#00 - Set Button

- ➔ If the vibration is not eliminated, use the ▲ and ▼ Buttons for the set frequency to fine-tune the value and click the **Set** Button again.

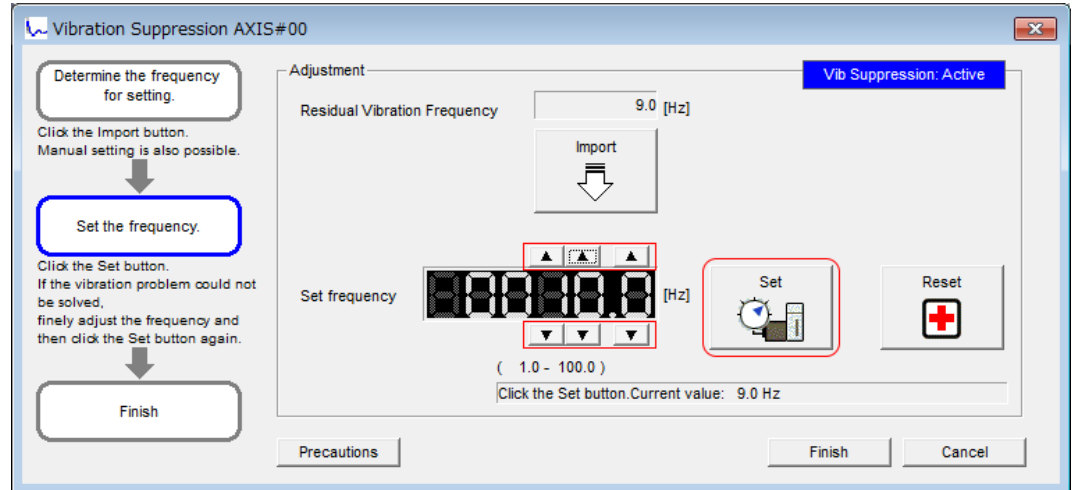


Fig. 278: Vibration Suppression AXIS#00 - Set frequency

Click the **Reset** Button during adjustment to restore the setting to its original value. The status from before when adjustment was started will be restored.

5. When the vibration has been eliminated, click the **Finish** Button.

The updated value will be saved in the SERVOPACK.

i *Vibration suppression will be enabled in step 5. The Servomotor response, however, will change when the Servomotor comes to a stop with no reference input.*

This concludes the procedure to set up vibration suppression.

9.11.6 Setting Combined Functions

You can also use the feedforward function when you execute vibration suppression.

In the default settings, feedforward (Pn109), the speed feedforward input (VFF), and the torque feedforward input (TFF) are disabled.

To use the speed feedforward input (VFF), the torque feedforward input (TFF), and model following control from the host controller in the system, set Pn140 to n.1□□□ (Use model following control and speed/torque feedforward together).

Parameter	Meaning	When Enabled	Classification
Pn140	n.0□□□ (default setting)	Immediately	Tuning
	n.1□□□		

i *When model following control is used with the feedforward function, it is used to make optimum feedforward settings in the SERVOPACK. Therefore, model following control is not normally used together with either the speed feedforward input (VFF) or torque feedforward input (TFF) from the host controller. However, model following control can be used with the speed feedforward input (VFF) or torque feedforward input (TFF) if required. An unsuitable feedforward input may result in overshooting.*

9.11.7 Related Parameters

The following parameters are automatically adjusted or used as reference when you execute vibration suppression.

Do not change the settings while vibration suppression is being executed.

Parameter	Name	Automatic Changes
Pn140	Model Following Control-Related Selections	Yes
Pn141	Model Following Control Gain	Yes
Pn142	Model Following Control Gain Correction	No
Pn143	Model Following Control Bias in the Forward Direction	No
Pn144	Model Following Control Bias in the Reverse Direction	No
Pn145	Vibration Suppression 1 Frequency A	Yes
Pn146	Vibration Suppression 1 Frequency B	Yes
Pn147	Model Following Control Speed Feedforward Compensation	No
Pn14A	Vibration Suppression 2 Frequency	No
Pn14B	Vibration Suppression 2 Correction	No

Yes: The parameter is automatically set.

No: The parameter is not automatically set, but the setting is read during execution.

9.12 Speed Ripple Compensation

9.12.1 Overview

This section describes speed ripple compensation.

9.12.2 Outline

Speed ripple compensation reduces the amount of ripple in the motor speed due to torque ripple or cogging torque. You can enable speed ripple compensation to achieve smoother operation. To enable it, you must set up ripple compensation on the SigmaWin+.



WARNING

Speed ripple compensation requires operating the Servomotor and therefore presents hazards. Observe the following precaution.

Confirm safety around moving parts.

This function involves automatic operation. Make sure that you can perform an emergency stop (to turn OFF the power supply) at any time.



Execute speed ripple compensation only after adjusting the gains.

- *Reset speed ripple compensation after you replace the Servomotor or SERVOPACK.*
- *Execute speed ripple compensation after jogging to a position that ensures a suitable range of motion.*

9.12.3 Setting Up Speed Ripple Compensation

Restrictions

The following restrictions apply to the setup for speed ripple compensation.

- Systems for Which Execution Cannot Be Performed
There are no restrictions.
- Systems for Which Adjustments Cannot Be Made Accurately
Systems for which there is not a suitable range of motion
- Preparations
Check the following items before you set up speed ripple compensation.
 - The main circuit power supply must be ON.
 - The servo must be OFF.
 - There must be no alarms or warnings.
 - There must be no hard wire base block (HWBB).
 - The parameters must not be write prohibited.


Applicable Tools

The following table lists the tools that you can use to set up speed ripple compensation and the applicable tool functions.

Tool	Function	Operating Procedure Reference
Digital Operator	You cannot set up speed ripple compensation from the Digital Operator.	
SigmaWin+	Solutions – Ripple Compensation	➔ ‘Operating Procedure’ ...page 362

Operating Procedure

Use the following procedure to set up speed ripple compensation.

1. ➔ Click the  Servo Drive Button in the workspace of the Main Window of the SigmaWin+.
2. ➔ Select Ripple Compensation in the Menu Dialog Box.
 - ➔ The Ripple Compensation Dialog Box will be displayed.

3. → Click the **OK** Button.

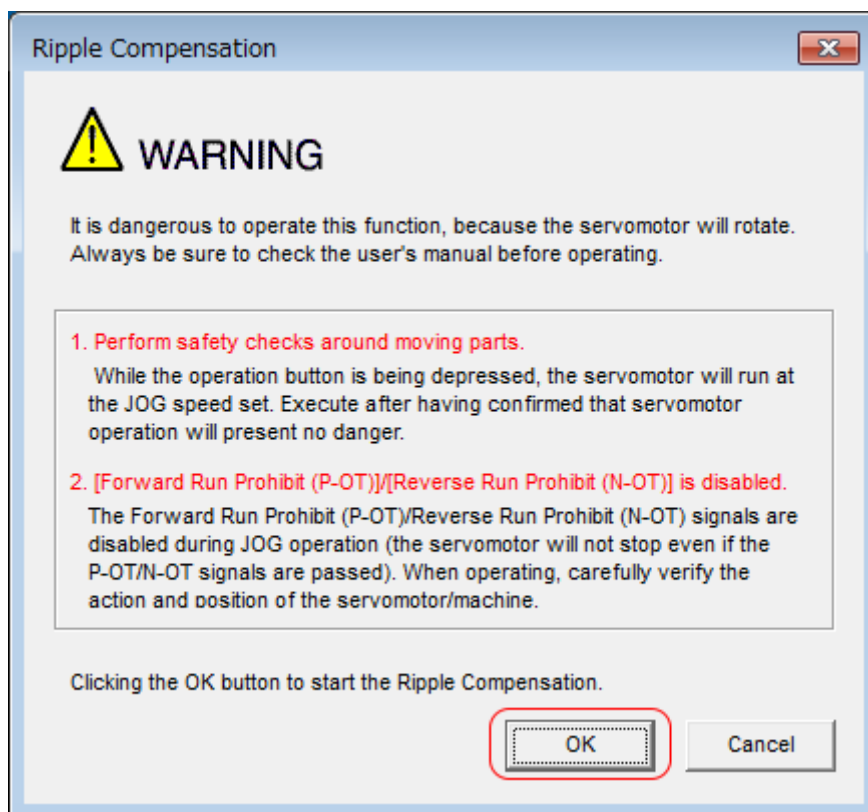


Fig. 279: Ripple Compensation - Warning



- Click the **Cancel** Button to cancel ripple compensation. The Main Window will return.
- If write protection is set, the following dialog box will be displayed.

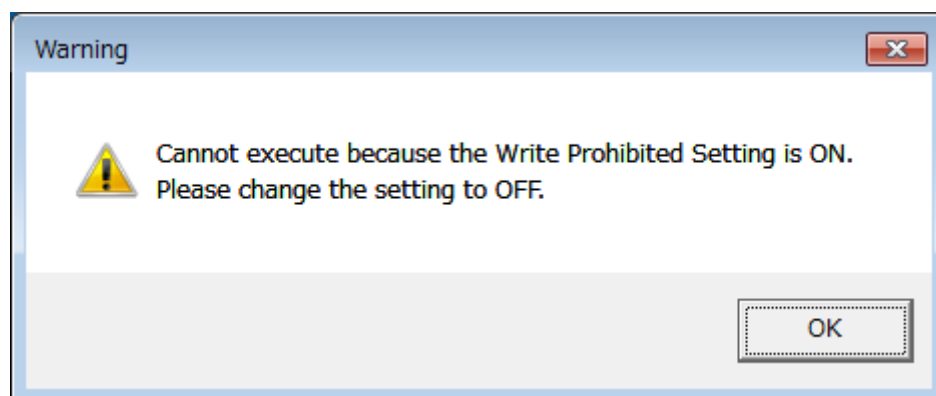


Fig. 280: Write Prohibited Setting - Warning

Click the **OK** Button to cancel write prohibition.

4. Click the **Edit** Button.

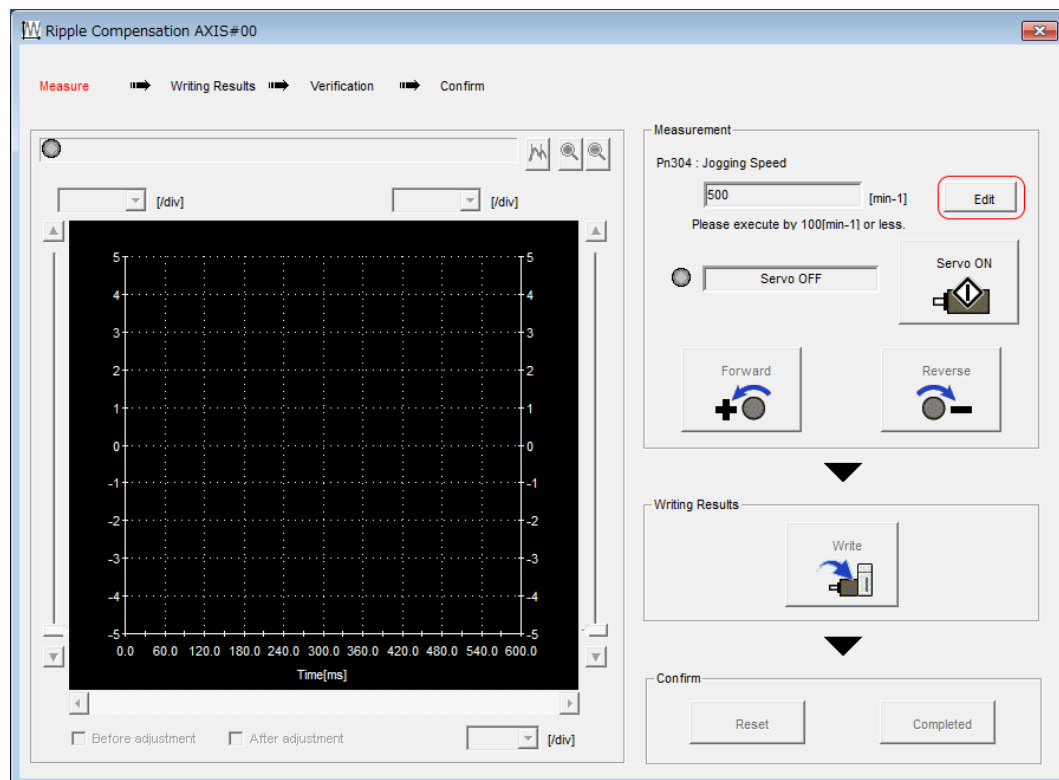


Fig. 281: Ripple Compensation AXIS#00 - Edit

5. Enter the jogging speed in the **Input Value** Box and click the **OK** Button.

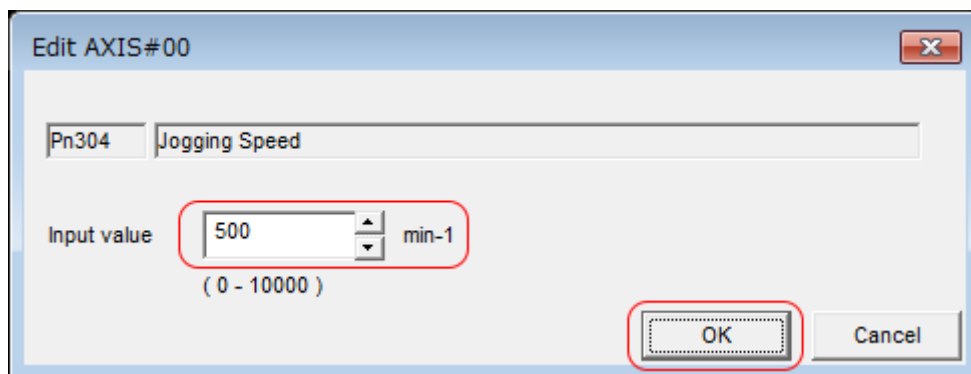


Fig. 282: Ripple Compensation AXIS#00 - Jogging Speed

6. Click the **Servo ON** Button.

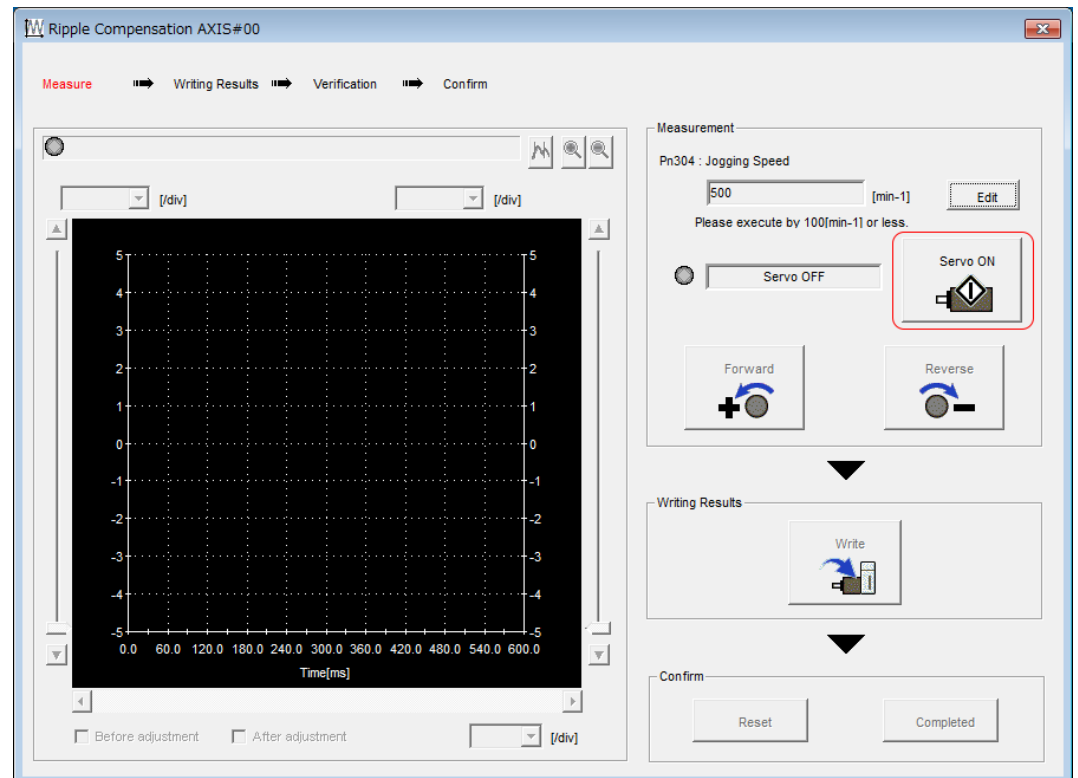


Fig. 283: Ripple Compensation AXIS#00 - Servo ON Button

7. ➔ Click the **Forward** Button or the **Reverse** Button.

Measurement operation is started.

The Servomotor shaft will rotate at the preset jogging speed while you hold down the **Forward** or **Reverse** Button and the speed ripple will be measured.

The feedback speed and torque reference graph will be displayed in the Ripple Compensation Dialog Box during jogging.

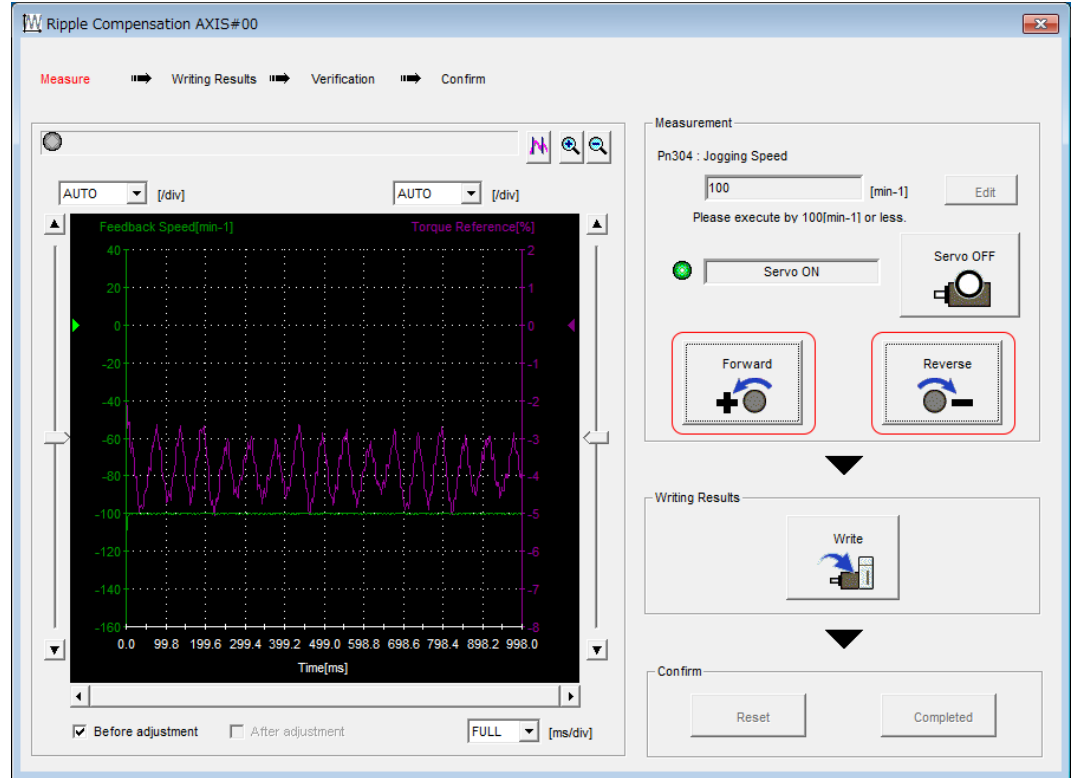


Fig. 284: Ripple Compensation AXIS#00 - Forward and Reverse Button

➔

i If the measurement time (i.e., the jogging time) for the speed ripple is too short, speed ripple measurement will not be completed. The following dialog box will be displayed if speed ripple measurement was not completed.

Click the **OK** Button and repeat the measurement.

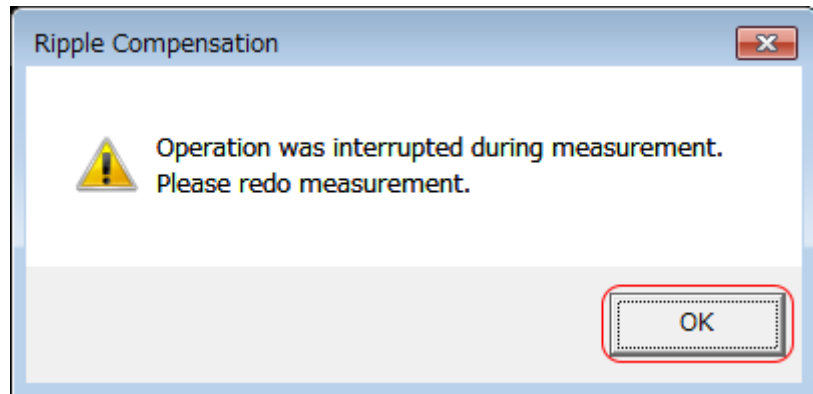


Fig. 285: Ripple Compensation - Operation was interrupted Dialog Box

8. ➔ After speed ripple measurement has been completed, click the **Write** Button.
 - ➔ The ripple compensation value will be written to the SERVOPACK.

9. After writing has been completed, click the **OK** Button.

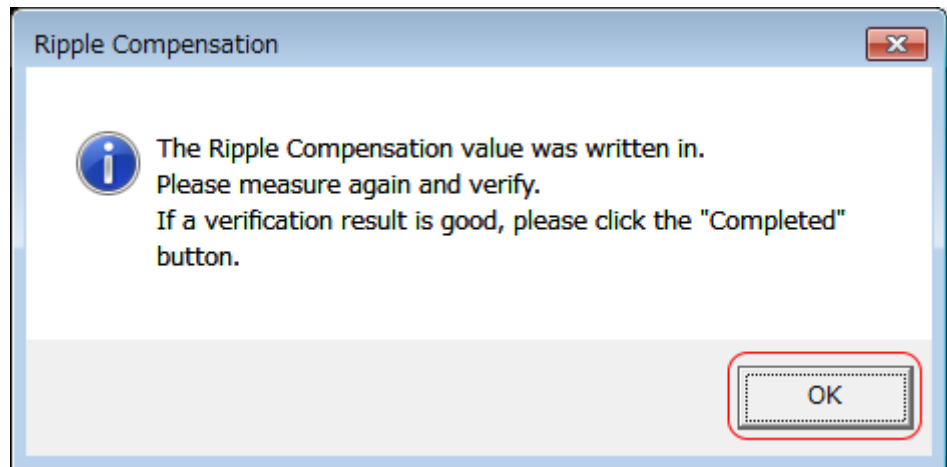


Fig. 286: Ripple Compensation - Writing completed Dialog Box

10. Click the **Forward** Button or the **Reverse** Button.

Verification operation is started.

The Servomotor shaft will rotate at the preset jogging speed while you hold down the **Forward** or **Reverse** Button.

The waveform with speed ripple compensation applied to it will be displayed.

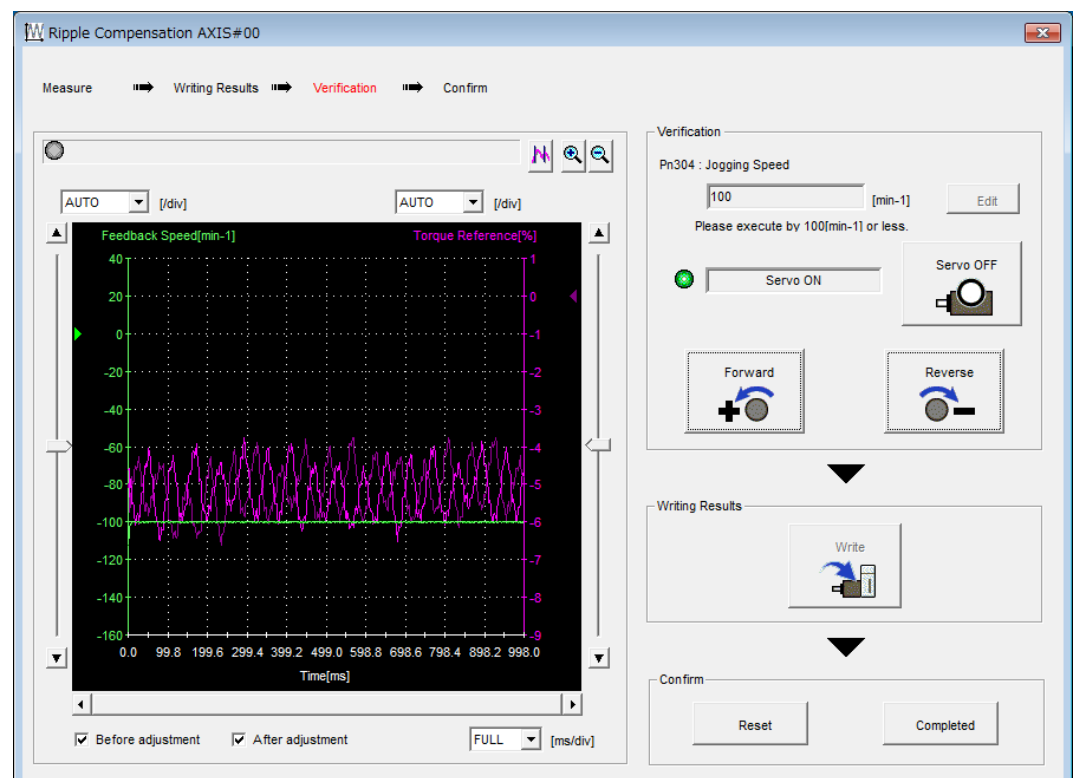



Fig. 287: Ripple Compensation - Verification Operation

11. If the verification results are OK, click the **Finish** Button.



To discard the setup results, click the **Reset** Button.

This concludes the setup for speed ripple compensation.

9.12.4 Setting Parameters

The function is enabled when you perform the operating procedure on [↔ 'Operating Procedure' ...page 362](#). To cancel speed ripple compensation, use Pn423 = n.□□□0 (Disable speed ripple compensation) to disable it.

Parameter	Meaning	When Enabled	Classification
Pn423	n.□□□0 (default setting)	Immediately	Setup
	n.□□□1		

If you enable speed ripple compensation, a compensation reference will be applied to reduce ripple even when stopped at a 0 speed reference. In speed control mode, this may result in the Servomotor moving slightly. To prevent this, set Pn423 = n.□X□□ (Speed Ripple Compensation Selections) and Pn427 or Pn49F (Speed Ripple Compensation Enable Speed).

Parameter	Meaning	When Enabled	Classification
Pn423	n.□0□□ (default setting)	After restart	Setup
	n.□1□□		

For Rotary Servomotors

Speed Ripple Compensation Enable Speed

	Setting Range	Setting Unit	Default Setting	When Enabled	Classification
Pn427	0 to 10,000	1 min ⁻¹	0	Immediately	Tuning

(applies to Speed Control, Position Control and Torque Control)

For Linear Servomotors

Speed Ripple Compensation Enable Speed

	Setting Range	Setting Unit	Default Setting	When Enabled	Classification
Pn49F	0 to 10,000	1 mm/s	0	Immediately	Tuning

(applies to Speed Control, Position Control and Force Control)

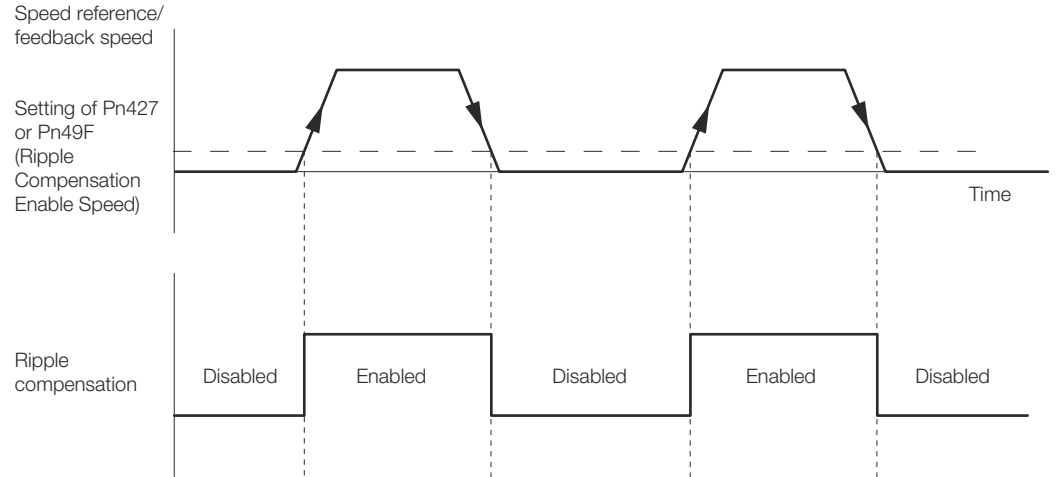


Fig. 288: Speed Ripple Compensation Enable Speed

Speed Ripple Compensation Warnings

The speed ripple compensation value is specific to each Servomotor. If you replace the Servomotor while speed ripple compensation is enabled, an A.942 warning (Speed Ripple Compensation Information Disagreement) will occur to warn you.

You can use any of the following methods to clear A.942.

- Reset the speed ripple compensation value on the SigmaWin+.
- Disable speed ripple compensation (Pn423 = n.□□□0).
- Disable detection of A.942 (Pn423 = n.□□1□).

Parameter	Meaning	When Enabled	Classification
Pn423	n.□□0□ (default setting)	After restart	Setup
	n.□□1□		

9.13 Additional Adjustment Functions

9.13.1 Overview

This section describes the functions that you can use to make adjustments after you perform autotuning without a host reference, autotuning with a host reference, and custom tuning.

Function	Applicable Control Methods	Reference
Gain Switching	Position control, speed control, or torque control*	↪ Chap. 9.13.2 'Gain Switching' ...page 370
Friction Compensation	Position control or speed control	↪ Chap. 9.13.3 'Friction Compensation' ...page 374
Current Control Mode Selection	Position control, speed control, or torque control	↪ Chap. 9.13.5 'Current Control Mode Selection' ...page 377

Function	Applicable Control Methods	Reference
Current Gain Level Setting	Position control or speed control	↪ Chap. 9.13.6 'Current Gain Level Setting' ...page 378
Speed Detection Method Selection	Position control, speed control, or torque control	↪ Chap. 9.13.7 'Speed Detection Method Selection' ...page 378
Backlash Compensation	Position Control	↪ Chap. 9.13.9 'Backlash Compensation' ...page 379

* Automatic gain switching is enabled only for position control.

9.13.2 Gain Switching

You can use gain switching to shorten the positioning time by increasing the gains during positioning and suppressing vibration by decreasing the gains while stopping.

Parameter	Meaning	When Enabled	Classification
Pn139	n.□□□0 (default setting)	Immediately	Tuning
	n.□□□2		

Note: Pn139 = n.□□□1 is a reserved setting. Do not use this setting.

Refer to the following section for gain switching combinations.

↪ ['Gain Switching Combinations' ...page 370](#)

Gain Switching Combinations

Selected Gains	Speed Loop Gain	Speed Loop Integral Time Constant	Position Loop Gain	Torque Reference Filter	Friction Compensation Gain
Gain Settings 1	Speed Loop Gain (Pn100)	Speed Loop Integral Time Constant (Pn101)	Position Loop Gain (Pn102)	First Stage First Torque Reference Filter Time Constant (Pn401)	Friction Compensation Gain (Pn121)
Gain Settings 2	Second Speed Loop Gain (Pn104)	Second Speed Loop Integral Time Constant (Pn105)	Second Position Loop Gain (Pn106)	First Stage Second Torque Reference Filter Time Constant (Pn412)	Second Friction Compensation Gain (Pn122)

Note: Automatic gain switching is not supported for Model Following Control Gain and Model Following Control Correction.

Automatic Gain Switching

Automatic gain switching is enabled only for position control. The switching conditions are specified by using the following settings.

Parameter		Switching Condition	Selected Gains	Switching Waiting Time	Switching Time
Pn139	n.□□□2	Condition A satisfied	Gain settings 1 to gain settings 2	Gain Switching Waiting Time 1 Pn135	Gain Switching Time 1 Pn131
		Condition A not satisfied	Gain settings 2 to gain settings 1	Gain Switching Waiting Time 2 Pn136	Gain Switching Time 2 Pn132

Select one of the following settings for switching condition A.

Parameter		Position Control Gain Switching Condition A	For Control Methods Other Than Positioning Control (No Switching)	When Enabled	Classification
Pn139	n.□□0□ (default setting)	/COIN (Positioning Completion) signal ON	Gain settings 1 used.	Immediately	Tuning
	n.□□1□	/COIN (Positioning Completion) signal OFF	Gain settings 2 used.		
	n.□□2□	/NEAR (Near) signal ON	Gain settings 1 used.		
	n.□□3□	/NEAR (Near) signal OFF	Gain settings 2 used.		
	n.□□4□	Position reference filter output is 0 and position reference input is OFF.	Gain settings 1 used.		
	n.□□5□	Position reference input is ON.	Gain settings 2 used.		

Automatic Switching Pattern 1 (Pn139 = n.□□□2)

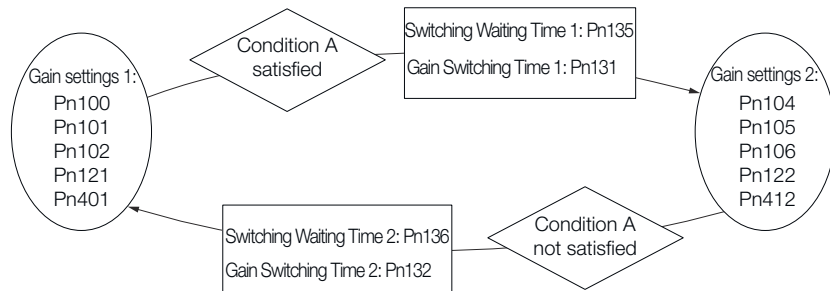


Fig. 289: Automatic Gain Switching

- Relationship between the Waiting Times and Switching Times for Gain Switching

In this example, an ON /COIN (Positioning Completion) signal is set as condition A for automatic gain switching. The position loop gain is changed from the value in Pn102 (Position Loop Gain) to the value in Pn106 (Second Position Loop Gain). When the /COIN signal turns ON, the switching operation begins after the waiting time (Pn135). The switching operation changes the position loop gain linearly from the gain set in Pn102 to the gain set in Pn106 over the switching time (Pn131).

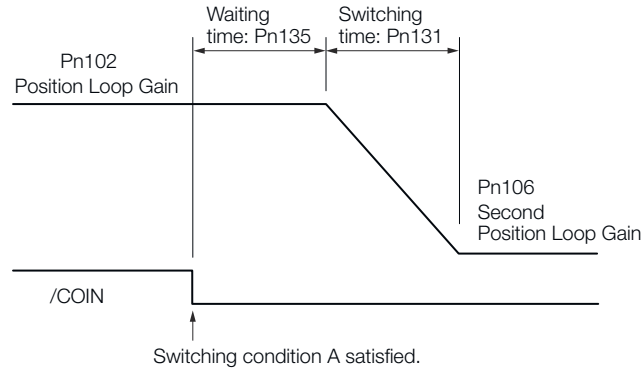


Fig. 290: Relationship between the Waiting Times and Switching Times for Gain Switching



You can use gain switching for either PI control or I-P control (Pn10B = n.□□0□ or □□1□).

Related Parameters

Speed Loop Gain

	Setting Range	Setting Unit	Default Setting	When Enabled	Classification
Pn100	10 to 20,000	0.1 Hz	400	Immediately	Tuning

(applies to Speed Control and Position Control)

Speed Loop Integral Time Constant

	Setting Range	Setting Unit	Default Setting	When Enabled	Classification
Pn101	15 to 51,200	0.01 ms	2,000	Immediately	Tuning

(applies to Speed Control and Position Control)

Position Loop Gain

	Setting Range	Setting Unit	Default Setting	When Enabled	Classification
Pn102	10 to 20,000	0.1/s	400	Immediately	Tuning

(applies to Position Control)

First Stage First Torque Reference Filter Time Constant

	Setting Range	Setting Unit	Default Setting	When Enabled	Classification
Pn401	0 to 65,535	0.01 ms	100	Immediately	Tuning

(applies to Speed Control, Position Control and Torque Control)

Friction Compensation Gain

	Setting Range	Setting Unit	Default Setting	When Enabled	Classification
Pn121	10 to 1,000	1%	100	Immediately	Tuning

(applies to Speed Control and Position Control)

Second Speed Loop Gain

	Setting Range	Setting Unit	Default Setting	When Enabled	Classification
Pn104	10 to 20,000	0.1 Hz	400	Immediately	Tuning

(applies to Speed Control and Position Control)

Second Speed Loop Integral Time Constant

	Setting Range	Setting Unit	Default Setting	When Enabled	Classification
Pn105	15 to 51,200	0.01 ms	2,000	Immediately	Tuning

(applies to Speed Control and Position Control)

Second Position Loop Gain

	Setting Range	Setting Unit	Default Setting	When Enabled	Classification
Pn106	10 to 20,000	0.1/s	400	Immediately	Tuning

(applies to Position Control)

First Stage Second Torque Reference Filter Time Constant

	Setting Range	Setting Unit	Default Setting	When Enabled	Classification
Pn412	0 to 65,535	0.01 ms	100	Immediately	Tuning

(applies to Speed Control, Position Control and Torque Control)

Second Friction Compensation Gain

	Setting Range	Setting Unit	Default Setting	When Enabled	Classification
Pn122	10 to 1,000	1%	100	Immediately	Tuning

(applies to Speed Control and Position Control)

Parameters Related to Automatic Gain Switching**Gain Switching Time 1**

	Setting Range	Setting Unit	Default Setting	When Enabled	Classification
Pn131	0 to 65,535	1 ms	0	Immediately	Tuning

(applies to Position Control)

Gain Switching Time 2

	Setting Range	Setting Unit	Default Setting	When Enabled	Classification
Pn132	0 to 65,535	1 ms	0	Immediately	Tuning

(applies to Position Control)

Gain Switching Waiting Time 1

	Setting Range	Setting Unit	Default Setting	When Enabled	Classification
Pn135	0 to 65,535	1 ms	0	Immediately	Tuning

(applies to Position Control)

Gain Switching Waiting Time 2

	Setting Range	Setting Unit	Default Setting	When Enabled	Classification
Pn136	0 to 65,535	1 ms	0	Immediately	Tuning

(applies to Position Control)

Related Monitoring

- SigmaWin+
You can monitor gain switching with the status monitor or with tracing.
- Analog Monitors

Parameter	Analog Monitor	Monitor Name	Output Value	Description
Pn006	n.□□0B	Active Gain Monitor	1 V	Gain settings 1 are enabled.
Pn007			2 V	Gain settings 2 are enabled.

9.13.3 Friction Compensation

Friction compensation is used to compensate for viscous friction fluctuations and regular load fluctuations.

You can automatically adjust friction compensation with autotuning without a host reference, autotuning with a host reference, or custom tuning, or you can manually adjust it with the following procedure.

Required Parameter Settings

The following parameter settings are required to use friction compensation.

Parameter	Function	When Enabled	Classification
Pn408	n.0□□□ (default setting)	Immediately	Setup
	n.1□□□		

Friction Compensation Gain

	Setting Range	Setting Unit	Default Setting	When Enabled	Classification
Pn121	10 to 1,000	1%	100	Immediately	Tuning

(applies to Speed Control and Position Control)

Second Friction Compensation Gain

	Setting Range	Setting Unit	Default Setting	When Enabled	Classification
Pn122	10 to 1,000	1%	100	Immediately	Tuning

(applies to Speed Control and Position Control)

Friction Compensation Coefficient

	Setting Range	Setting Unit	Default Setting	When Enabled	Classification
Pn123	0 to 100	1%	100	Immediately	Tuning

(applies to Speed Control and Position Control)

Friction Compensation Frequency Correction

	Setting Range	Setting Unit	Default Setting	When Enabled	Classification
Pn124	-10,000 to 10,000	0.1 Hz	0	Immediately	Tuning

(applies to Speed Control and Position Control)

Friction Compensation Gain Correction

	Setting Range	Setting Unit	Default Setting	When Enabled	Classification
Pn125	1 to 1,000	1%	100	Immediately	Tuning

(applies to Speed Control and Position Control)

Operating Procedure for Friction Compensation

Use the following procedure to perform friction compensation.

**CAUTION**

Before you execute friction compensation, set the moment of inertia ratio (Pn103) as accurately as possible. If the setting greatly differs from the actual moment of inertia, vibration may occur.

Step	Operation
1	<p>Set the following parameters related to friction compensation to their default settings.</p> <p>Friction Compensation Gain (Pn121): 100</p> <p>Second Friction Compensation Gain (Pn122): 100</p> <p>Friction Compensation Coefficient (Pn123): 0</p> <p>Friction Compensation Frequency Correction (Pn124): 0</p> <p>Friction Compensation Gain Correction (Pn125): 100</p> <p>Note: Always use the default settings for the Friction Compensation Frequency Correction (Pn124) and Friction Compensation Gain Correction (Pn125).</p>

Step	Operation
2	<p>Gradually increase the Friction Compensation Coefficient (Pn123) to check the effect of friction compensation.</p> <p>Note: Usually, set the Friction Compensation Coefficient (Pn123) to 95% or less.</p> <p>If the effect is insufficient, increase the Friction Compensation Gain (Pn121) by 10% increments until vibration stops.</p> <p>Effect of Adjusted Parameters</p> <p>Pn121: Friction Compensation Gain and Pn122: Second Friction Compensation Gain</p> <p>These parameters set the response to external disturbances. The higher the setting is, the better the response will be. If the machine has a resonance frequency, however, vibration may occur if the setting is too high.</p> <p>Pn123: Friction Compensation Coefficient</p> <p>This parameter sets the effect of friction compensation. The higher the setting is, the more effective friction compensation will be. If the setting is too high, however, vibration will occur more easily. Usually, set the value to 95% or less.</p>
3	<p>Effect of Adjustments</p> <p>The following graphs show the response with and without adjustment.</p>

9.13.4 Gravity Compensation

When the Servomotor is used with a vertical axis, gravity compensation prevents the moving part from falling due to the machine's own weight when the brake is released. SERVOPACKs with software version 0023 or higher support gravity compensation.

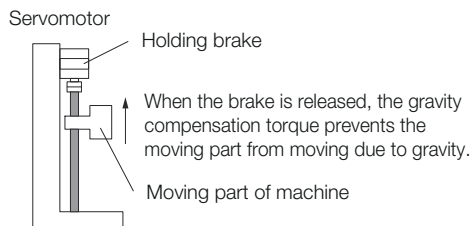


Fig. 291: Gravity Compensation - Holding Brake Released

A timing chart for when the moving part is raised then lowered is provided below.

Refer to the following section for details on brake operation timing.

➔ [Chap. 6.12.2 'Brake Operating Sequence' ...page 162](#)

Additional Adjustment Functions > Current Control Mode Selection

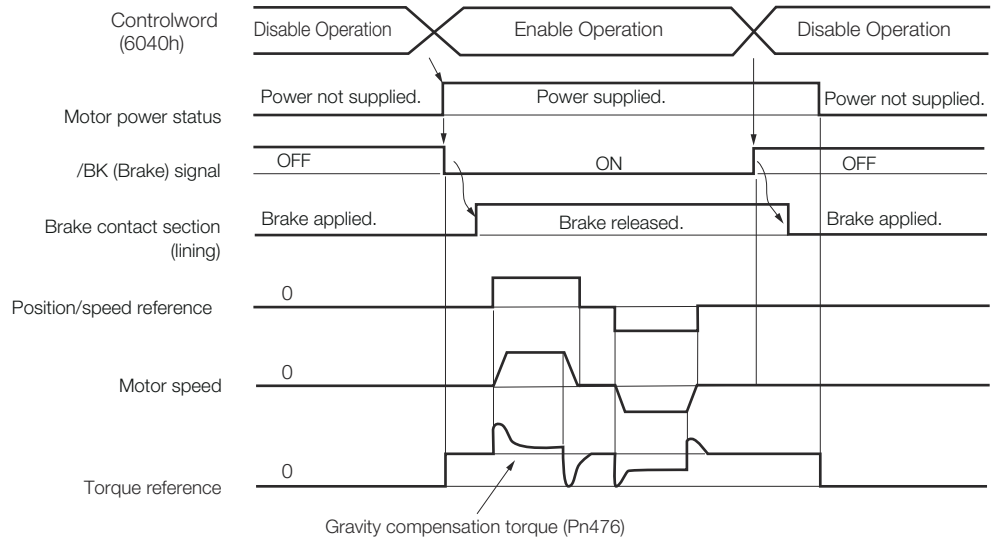


Fig. 292: Gravity Compensation - Timing Chart

Required Parameter Settings

The following parameter settings are required to use gravity compensation.

Parameter	Function	When Enabled	Classification
Pn475	n.□□□0 (default setting)	After restart	Setup
	n.□□□1		

Gravity Compensation Torque

Setting	Setting Range	Setting Unit	Default Setting	When Enabled	Classification
Pn476	-1,000 to 1,000	0.1%	0	Immediately	Tuning

(applies to Speed Control, Position Control and Torque Control)

Operating Procedure for Gravity Compensation

Use the following procedure to perform gravity compensation.

1. Set Pn475 to n.□□□1 (Enable gravity compensation).
2. To enable changes to the settings, turn the power supply to the SERVOPACK OFF and ON again.
3. Use SigmaWin+ or an analog monitor to find the torque reference value when the motor is stopped with the servo ON.
4. Set the torque reference value found in step 3 in Pn476 (Gravity Compensation Torque).
5. Turn the servo ON and OFF a few times and fine-tune Pn476 so that the moving part of the machine does not fall.

9.13.5 Current Control Mode Selection

Current control mode selection reduces high-frequency noise while the Servomotor is being stopped.

The setting depends on the capacity of the SERVOPACK.

SERVOPACK Models SGD7S-R70A, -R90A, -1R6A, -2R8A, -3R8A, -5R5A, and -7R6A

Parameter		Function	When Enabled	Classification
Pn009	n. □□0□	Use current control mode 1.	After restart	Tuning
	n. □□1□ (default setting)			
	n. □□2□	Use current control mode 2 (low noise).		

SERVOPACK Models SGD7S-120A, -180A, -200A, -330A, -470A, -550A, -590A, and -780A

Parameter		Function	When Enabled	Classification
Pn009	n. □□0□	Use current control mode 1.	After restart	Tuning
	n. □□1□ (default setting)			
	n. □□2□	Use current control mode 2 (low noise).		



If current control mode 2 is selected, the load ratio may increase while the Servomotor is being stopped.

9.13.6 Current Gain Level Setting

You can set the current gain level to reduce noise by adjusting the parameter for current control inside the SERVOPACK according to the speed loop gain (Pn100). The noise level can be reduced by decreasing the current gain level (Pn13D) from its default setting of 2,000% (disabled). However, if the setting is decreased, the level of noise will be lowered, but the response characteristic of the SERVOPACK will also be reduced. Adjust the current gain level within the range that maintains the SERVOPACK response characteristic.

Current Gain Level

	Setting Range	Setting Unit	Default Setting	When Enabled	Classification
Pn13D	100 to 2,000	1%	2,000	Immediately	Tuning

(applies to Speed Control and Position Control)



If the current gain level is changed, the response characteristic of the speed loop will also change. Servo tuning must therefore be performed again.

9.13.7 Speed Detection Method Selection

You can use the speed detection method selection to ensure smooth Servomotor speed changes during operation. To ensure smooth motor speed changes during operation, set Pn009 to n.□1□□ (Use speed detection 2).

With a Linear Servomotor, you can reduce the noise level of the running motor when the linear encoder scale pitch is large.

Parameter	Function	When Enabled	Classification
Pn009	n. □0□□ (default setting)	After restart	Tuning
	n. □1□□		



If the speed detection method is changed, the response characteristic of the speed loop will also change. Servo tuning must therefore be performed again.

9.13.8 Speed Feedback Filter

You can set a first order lag filter for the speed feedback in the speed loop. This ensures smooth changes in the feedback speed to reduce vibration. If a large value is set, it will increase the delay and make response slower.

Speed Feedback Filter Time Constant

	Setting Range	Setting Unit	Default Setting	When Enabled	Classification
Pn308	0 to 65,535 (0.00 ms to 655.35 ms)	0.01 ms	0 (0.00 ms)	Immediately	Setup

(applies to Speed Control and Position Control)

9.13.9 Backlash Compensation

Outline

If you drive a machine that has backlash, there will be deviation between the travel distance in the position reference that is managed by the host controller and the travel distance of the actual machine. Use backlash compensation to add the backlash compensation value to the position reference and use the result to drive the Servomotor. This will ensure that the travel distance of the actual machine will be the same as the travel distance in the host controller.



- Backlash compensation can be used only with a Rotary Servomotor.
- Backlash compensation can be used only for position control.

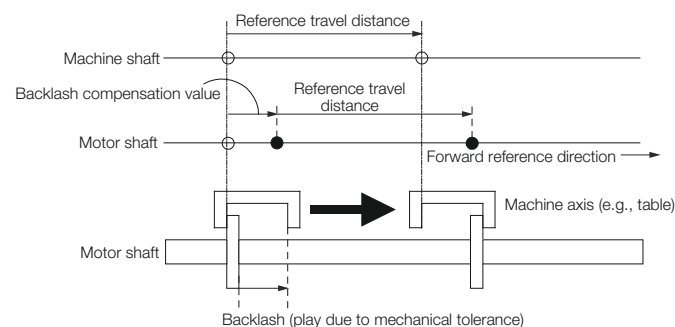


Fig. 293: Backlash compensation

Related Parameters

Set the following parameters to use backlash compensation.

- **Backlash Compensation Direction**
Set the direction in which to apply backlash compensation.

Parameter		Function	When Enabled	Classification
Pn230	n. □□□0 (default setting)	Compensate forward references.	After restart	Setup
	n. □□□1	Compensate reverse references.		

- **Backlash Compensation Value**
Set the amount of backlash compensation to add to the position reference. The amount is set in increments of 0.1 reference unit. However, when the amount is converted to encoder pulses, it is rounded off at the decimal point.

Example

When Pn231 = 6553.6 [reference units] and position reference unit (Numerator/Denominator) = 1/1:

$$6,553.6 \times 1 = 6,553.6 \text{ [pulses]}$$

⇒ The backlash compensation will be 6,553 encoder pulses.

Backlash Compensation

	Setting Range	Setting Unit	Default Setting	When Enabled	Classification
Pn231	-500,000 to 500,000	0.1 reference units	0	Immediately	Setup

(applies to Position Control)



The backlash compensation value is restricted by the following formula. Backlash compensation is not performed if this condition is not met.

$$Pn231 \leq \frac{\text{Denominator}}{\text{Numerator}} \times \frac{\text{Maximum motor speed [min}^{-1}\text{]}}{60} \times \text{Encoder resolution}^* \times 0.00025$$

Fig. 294: Backlash Compensation Value - Formula

*Refer to the following section for the encoder resolution.

→ [Chap. 6.15.1 'Setting Unit Systems' ...page 171](#)

With fully-closed loop control, substitute the number of external encoder pulses per motor rotation for the encoder resolution in the above formula.

Example 1

Denominator = 1, Numerator = 1, Maximum motor speed = 6,000 [min⁻¹], and Encoder resolution = 16,777,216 (24 bits)

$$1/4 \times 6,000/60 \times 16,777,216 \times 0.00025 = 104,857.6 \text{ [reference units]}$$

⇒ The backlash compensation will be limited to 104,857.6 reference units.

Example 2

Denominator = 1, Numerator = 1, Maximum motor speed = 6,000 [min⁻¹], Number of External Encoder Scale Pitches (Pn20A) = 500, and Use of the JZDP-H00□-000 (signal resolution: 1/ 256):

$$1/4 \times 6,000/60 \times (500 \times 256) \times 0.00025 = 800.0 \text{ [reference units]}$$

⇒ The backlash compensation will be limited to 800.0 reference units.



Do not exceed the upper limit of the backlash compensation value. You can check the upper limit on the operation monitor of the SigmaWin+.

■ Backlash Compensation Time Constant

You can set a time constant for a first order lag filter for the backlash compensation value (Pn231) that is added to the position reference.

If you set Pn233 (Backlash Compensation Time Constant) to 0, the first order lag filter is disabled.

Backlash Compensation Time Constant

	Setting Range	Setting Unit	Default Setting	When Enabled	Classification
Pn233	0 to 65,535	0.01 ms	0	Immediately	Setup

(applies to Position Control)



Changes to the settings are applied when there is no reference pulse input and the Servomotor is stopped.

The current operation is not affected if the setting is changed during Servomotor operation.

Related Monitoring

You can monitor the following values on the operation monitor of the SigmaWin+.

Displayed Value	Setting Unit
Current Backlash Compensation Value	0.1 reference units
Backlash Compensation Value Setting Limit	0.1 reference units

Compensation Operation

This section describes the operation that is performed for backlash compensation.



The following figures are for when backlash compensation is applied to references in the forward direction (Pn230 = n.□□□0). The following monitor information is provided in the figures: Target Position (607Ah) (target position in the reference coordinate system), Position Demand Value (6062h) (reference position in the reference coordinate system), and Position Actual Value (6064h) (feedback position in the machine coordinate system). The monitor information includes the feedback position in machine coordinate system (position actual value) and other feedback information. The backlash compensation value is subtracted from the feedback positions in the monitor information, so it is not necessary for the host controller to consider the backlash compensation value.



CAUTION

The encoder divided pulse output will output the number of encoder pulses for which driving was actually performed, including the backlash compensation value. If you use the encoder output pulses for position feedback at the host controller, you must consider the backlash compensation value.

■ Operation When the Servo Is ON

The backlash compensation value (Pn231) is added in the backlash compensation direction when the servo is ON (i.e., while power is supplied to the motor) and a reference is input in the same direction as the backlash compensation direction (Pn230.0 = n.□□□X). When there is a reference input in the direction opposite to the backlash compensation direction, the backlash compensation value is not added (i.e., backlash compensation is not performed).

The relationship between *Position Actual Value* (6064h) and the motor shaft position is as follows:

- If a reference is input in the compensation direction: Position Actual Value (6064h) = Motor shaft position - Pn231
- If a reference is input in the direction opposite to the compensation direction: Position Actual Value (6064h) = Motor shaft position

The following figure shows driving the Servomotor in the forward direction from Target Position 0 (Target Position: 607Ah) to Target Position 1 and then to Target Position 2, and then returning from Target Position 2 to Target Position 1 and then to Target Position 0.

Backlash compensation is applied when moving from Target Position 0 to Target Position 1, but not when moving from Target Position 2 to Target Position 1.

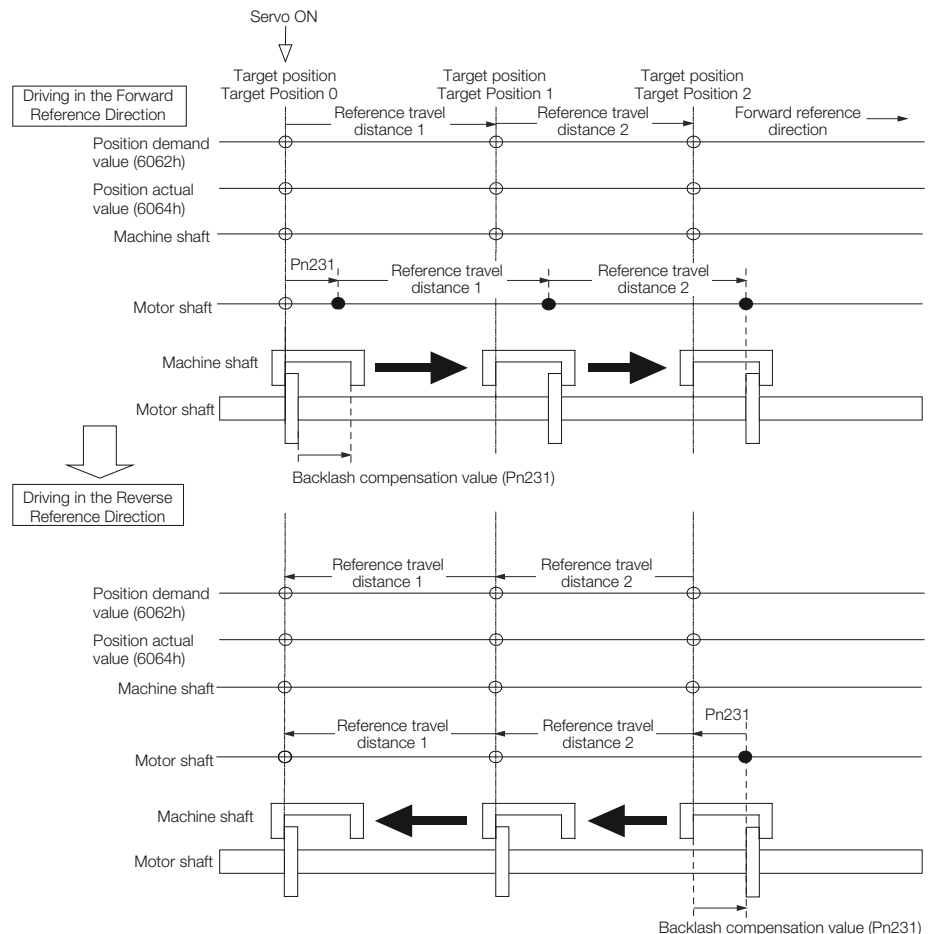


Fig. 295: Backlash Compensation - Operation When the Servo Is ON

■ Operation When the Servo Is OFF

Backlash compensation is not applied when the servo is OFF (i.e., when power is not supplied to motor). Therefore, the reference position (Position Demand Value (6062h)) is moved by only the backlash compensation value.

The relationship between *Position Actual Value* (6064h) and the motor shaft position is as follows:

- When servo is OFF: Position Actual Value (6064h) = Servomotor shaft position

The following figure shows what happens when the servo is turned OFF after driving the Servomotor in the forward direction from target position Target Position 0 to Target Position 1. Backlash compensation is not applied when the servo is OFF. (The SERVOPACK manages the position data so that *Position Actual Value* (6064h) and *Position Demand Value* (6062h) are the same.)

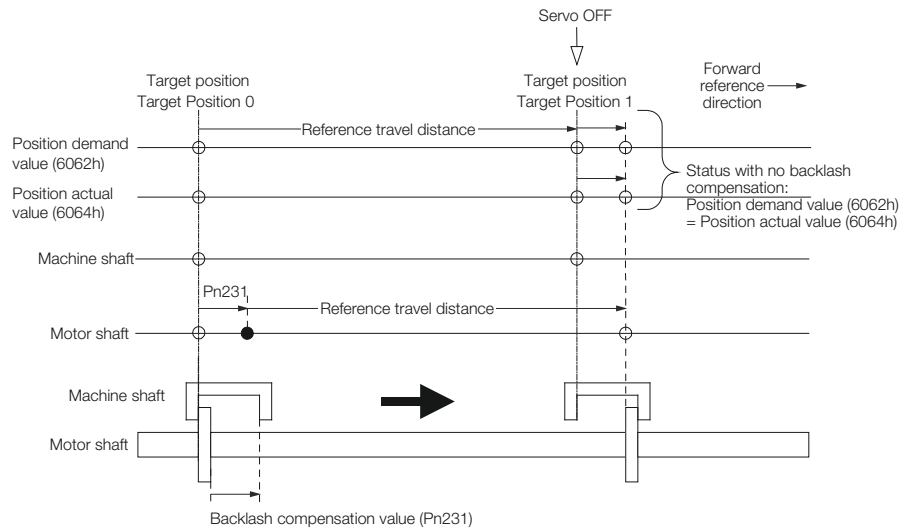


Fig. 296: Backlash Compensation - Operation When the Servo Is OFF

- Operation When There Is Overtravel

When there is overtravel (i.e., when driving is prohibited due to an overtravel signal or software limit), the operation is the same as for when the servo is OFF (Fig. 296), i.e., backlash compensation is not applied.

- Operation When Control Is Changed

Backlash compensation is performed only for position control.

Backlash compensation is not applied when position control is changed to any other control method.

Backlash compensation is applied in the same way as when the servo is ON (Fig. 295) if any other control method is changed to position control.

Related Monitoring

You can monitor the following values on the operation monitor of the SigmaWin+.

Displayed Value	Unit	Specification
Input Reference Pulse Speed	min ⁻¹	Displays the input reference pulse speed before backlash compensation.
Position Deviation	Reference units	Displays the position deviation for the position reference after backlash compensation.
Input Reference Pulse Counter	Reference units	Displays the input reference pulse counter before backlash compensation.
Feedback Pulse Counter	Encoder pulses	Displays the number of pulses from the actually driven motor encoder.
Fully-Closed Feedback Pulse Counter	External encoder resolution	Displays the number of pulses of the actually driven external encoder.

Displayed Value	Unit	Specification
Feedback Pulse Counter	Reference units	Displays the number of pulses from the actually driven encoder in reference units.

■ Related Monitoring Diagrams

The following symbols are used in the related monitoring diagrams.

- [A]: Analog monitor
- [P]: PROFINET monitor Information
- [U]: Monitor mode (Un monitor)
- [O]: Output signal
- [T]: Trace data

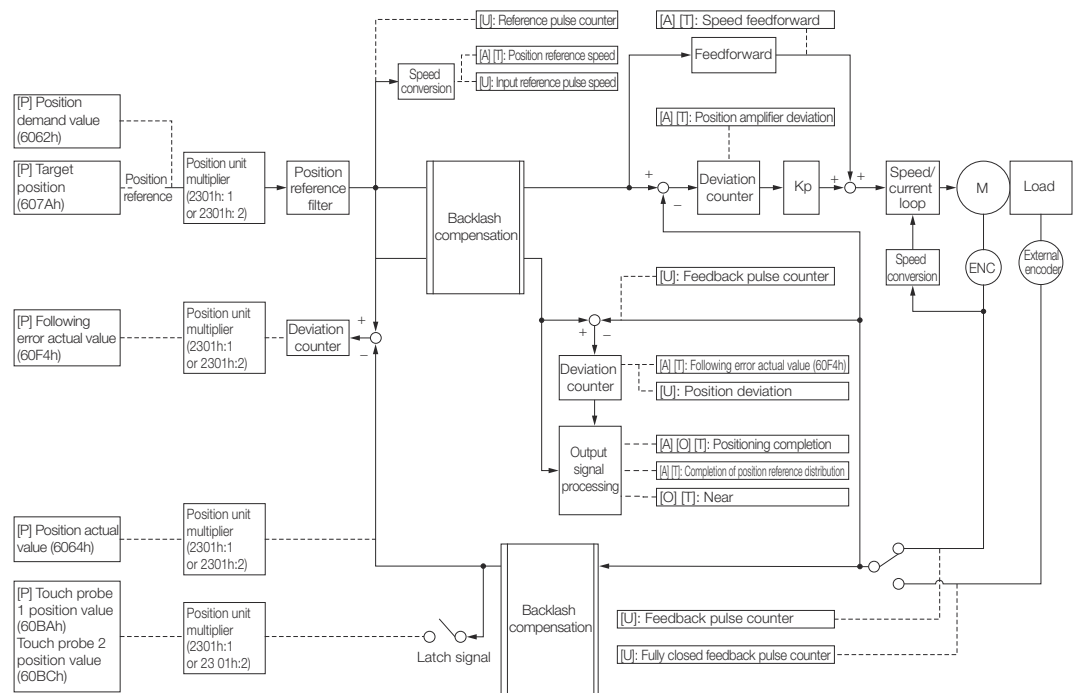


Fig. 297: Backlash Compensation - Related Monitoring Diagrams

9.14 Manual Tuning

9.14.1 Overview

This section describes manual tuning.

9.14.2 Tuning the Servo Gains

Servo Gains

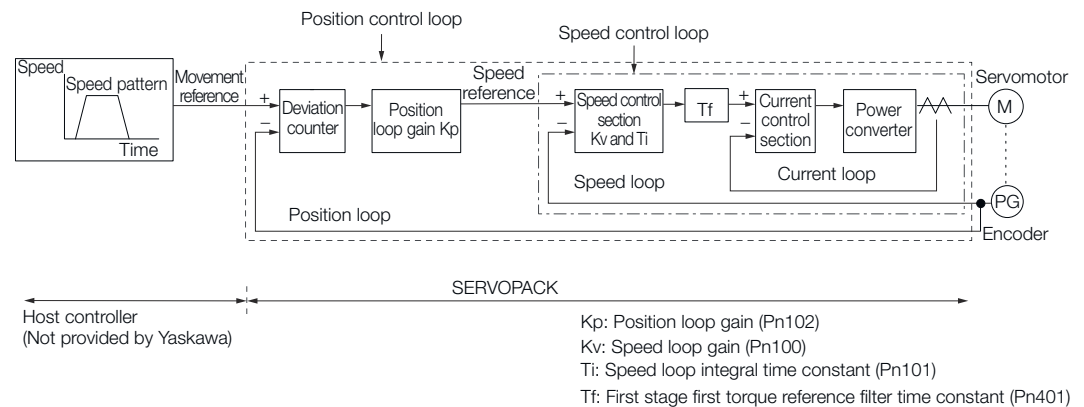


Fig. 298: Tuning the Servo Gains

In order to manually tune the servo gains, you must understand the configuration and characteristic of the SERVOPACK and adjust the servo gains individually. In most cases, if you greatly change any one parameter, you must adjust the other parameters again. To check the response characteristic, you must prepare a measuring instrument to monitor the output waveforms from the analog monitor.

The SERVOPACK has three feedback systems (the position loop, speed loop, and current loop), and the response characteristic must be increased more with the inner loops. If this relationship is not maintained, the response characteristic will suffer and vibration will occur more easily.

A sufficient response characteristic is ensured for the current loop. There is never a need for it to be adjusted by the user.

Outline

You can use manual tuning to set the servo gains in the SERVOPACK to increase the response characteristic of the SERVOPACK. For example, you can reduce the positioning time for position control.

Use manual tuning in the following cases.

- When tuning with autotuning without a host reference or autotuning with a host reference does not achieve the desired results
- When you want to increase the servo gains higher than the gains that resulted from autotuning without a host reference or autotuning with a host reference
- When you want to determine the servo gains and moment of inertia ratio yourself

You start manual tuning either from the default parameter settings or from the gain settings that resulted from autotuning without a host reference or autotuning with a host reference.

Applicable Tools

You can monitor the servo gains with the SigmaWin+ or with the analog monitor.

Precautions

Vibration may occur while you are tuning the servo gains. We recommend that you enable vibration alarms (Pn310 = n.□□□2) to detect vibration. Refer to the following section for information on vibration detection.

→ [Chap. 7.12.1 'Initializing the Vibration Detection Level' ...page 236](#)

Vibration alarms are not detected for all vibration. Also, an emergency stop method is necessary to stop the machine safely when an alarm occurs. You must provide an emergency stop device and activate it immediately whenever vibration occurs.

**Tuning Procedure Example
(for Position Control or
Speed Control)**

Step	Description
1	Adjust the first stage first torque reference filter time constant (Pn401) so that vibration does not occur.
2	Increase the position loop gain (Pn100) and reduce the speed loop integral time constant (Pn101) as far as possible within the range that does not cause machine vibration.
3	Repeat steps 1 and 2 and return the settings about 10% to 20% from the values that you set.
4	For position control, increase the position loop gain (Pn102) within the range that does not cause vibration.



If you greatly change any one servo gain parameter, you must adjust the other parameters again. Do not increase the setting of just one parameter. As a guideline, adjust the settings of the servo gains by approximately 5% each. As a rule, change the servo parameters in the following order.

- *To Increase the Response Speed*
 - *Reduce the torque reference filter time constant.*
 - *Increase the speed loop gain.*
 - *Decrease the speed loop integral time constant.*
 - *Increase the position loop gain.*
- *To Reduce Response Speed and to Stop Vibration and Overshooting*
 - *Reduce the position loop gain.*
 - *Increase the speed loop integral time constant.*
 - *Decrease the speed loop gain.*
 - *Increase the torque filter time constant.*

Adjusted Servo Gains

You can set the following gains to adjust the response characteristic of the SERVOPACK.

- Pn100: Speed Loop Gain
- Pn101: Speed Loop Integral Time Constant
- Pn102: Position Loop Gain
- Pn401: First Stage First Torque Reference Filter Time Constant
- Position Loop Gain

The position loop gain determines the response characteristic of the position loop in the SERVOPACK. If you can increase the setting of the position loop gain, the response characteristic will improve and the positioning time will be shortened. However, you normally cannot increase the position loop gain higher than the inherit vibration frequency of the machine system. Therefore, to increase the setting of the position loop gain, you must increase the rigidity of the machine to increase the inherit vibration frequency of the machine.

Position Loop Gain

	Setting Range	Setting Unit	Default Setting	When Enabled	Classification
Pn102	10 to 20,000	0.1/s	400	Immediately	Tuning

(applies to Position Control)



For machines for which a high position loop gain (Pn102) cannot be set, overflow alarms can occur during high-speed operation. If that is the case, you can increase the setting of the following parameter to increase the level for alarm detection.

Use the following condition as a guideline for determining the setting.

$$Pn520 \geq \frac{\text{Maximum feed speed [reference units/s]}}{Pn102 \div 10 (1/s)} \times 2.0$$

Fig. 299: Pn520 (Position Deviation Overflow Alarm Level) setting

If you use a position reference filter, transient deviation will increase due to the filter time constant. When you make the setting, consider deviation accumulation that may result from the filter.

Position Deviation Overflow Alarm Level

	Setting Range	Setting Unit	Default Setting	When Enabled	Classification
Pn520	1 to 1,073,741,823	1 reference unit	5,242,880	Immediately	Setup

(applies to Position Control)

Speed Loop Gain

This parameter determines the response characteristic of the speed loop. If the response characteristic of the speed loop is low, it becomes a delay factor for the position loop located outside of the speed loop. This will result in overshooting and vibration in the speed reference.

Therefore, setting the speed loop gain as high as possible within the range that will not cause the machine system to vibrate will produce a stable Servo System with a good response characteristic.

Speed Loop Gain

	Setting Range	Setting Unit	Default Setting	When Enabled	Classification
Pn100	10 to 20,000	0.1 Hz	400	Immediately	Tuning

(applies to Speed Control, Position Control and Torque Control)

$$\text{Setting of Pn103} = \frac{\text{Load moment of inertia at motor shaft (J}_L)}{\text{Servomotor moment of inertia (J}_M)} \times 100(\%)$$

Fig. 300: Pn103 (Moment of Inertia Ratio) setting

The default setting of Pn103 (Moment of Inertia Ratio) is 100. Before you tune the servo, calculate the moment of inertia ratio with the above formula and set Pn103 to the calculation result.

Moment of Inertia Ratio

	Setting Range	Setting Unit	Default Setting	When Enabled	Classification
Pn103	0 to 20,000	1%	100	Immediately	Tuning

(applies to Speed Control, Position Control and Torque Control)

Speed Loop Integral Time Constant

To enable response to even small inputs, the speed loop has an integral element. The integral element becomes a delay factor in the Servo System. If the time constant is set too high, overshooting will occur, positioning settling time will increase, and the response characteristic will suffer.

Speed Loop Integral Time Constant

	Setting Range	Setting Unit	Default Setting	When Enabled	Classification
Pn101	15 to 51,200	0.01 ms	2,000	Immediately	Tuning

(applies to Speed Control and Position Control)

■ Torque Reference Filter

As shown in the following diagram, the torque reference filter contains a first order lag filter and notch filters arranged in series, and each filter operates independently.

The notch filters can be enabled and disabled with Pn408 = n.□X□X and Pn416 = n.□XXX.

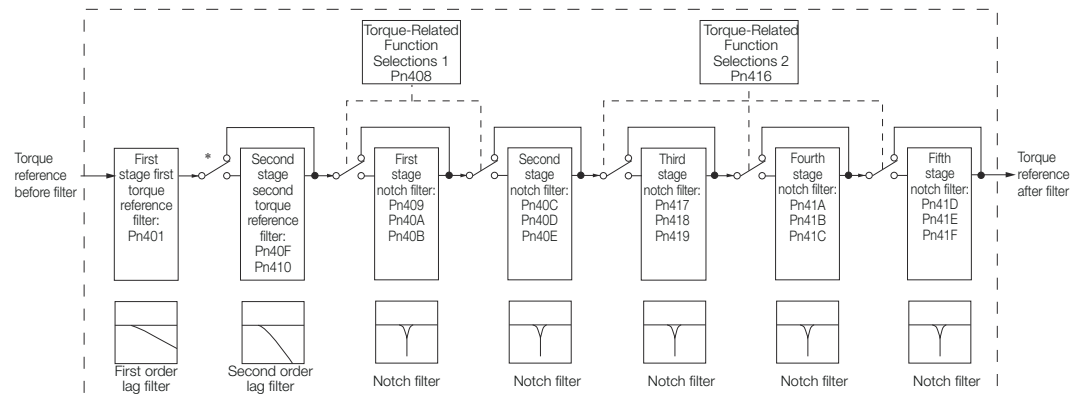


Fig. 301: Torque Reference Filter

* The second stage second torque reference filter is disabled when Pn40F is set to 5,000 (default setting) and it is enabled when Pn40F is set to a value lower than 5,000.

■ Torque Reference Filter

If you suspect that machine vibration is being caused by the Servo Drive, try adjusting the torque reference filter time constant. This may stop the vibration. The lower the value, the better the control response characteristic will be, but there may be a limit depending on the machine conditions.

First Stage First Torque Reference Filter Time Constant

	Setting Range	Setting Unit	Default Setting	When Enabled	Classification
Pn401	0 to 65,535	0.01 ms	100	Immediately	Tuning

(applies to Speed Control, Position Control and Torque Control)

Second Stage Second Torque Reference Filter Frequency

	Setting Range	Setting Unit	Default Setting	When Enabled	Classification
Pn40F	100 to 5,000	1 Hz	5000*	Immediately	Tuning

(applies to Speed Control, Position Control and Torque Control)

Second Stage Second Torque Reference Filter Q Value

	Setting Range	Setting Unit	Default Setting	When Enabled	Classification
Pn410	50 to 100	0.01	50	Immediately	Tuning

(applies to Speed Control, Position Control and Torque Control)

* The filter is disabled if you set the parameter to 5,000.

■ Notch Filters

The notch filter can eliminate specific frequency elements generated by the vibration of sources such as resonance of the shaft of a ball screw.

The notch filter puts a notch in the gain curve at the specific vibration frequency (called the notch frequency). The frequency components near the notch frequency can be reduced or removed with a notch filter.

Notch filters are set with three parameters for the notch filter frequency, notch filter Q value, and notch filter depth. This section describes the notch filter Q value and notch filter depth.

Notch filter Q Value

The setting of the notch filter Q value determines the width of the frequencies that are filtered for the notch filter frequency. The width of the notch changes with the notch filter Q value. The larger the notch filter Q value is, the steeper the notch is and the narrower the width of frequencies that are filtered is.

The notch filter frequency characteristics for different notch filter Q values are shown below.

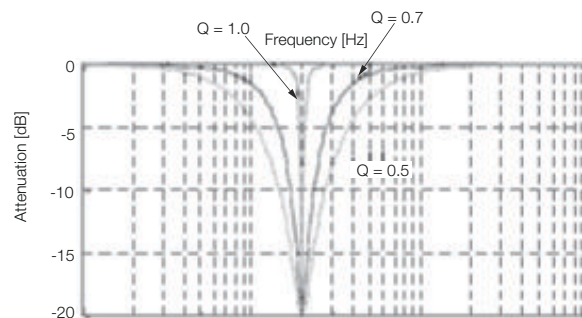


Fig. 302: Notch Filter Frequency Characteristics - Filter Q Values



The above notch filter frequency characteristics are based on calculated values and may be different from actual characteristics.

Notch Filter Depth

The setting of the notch filter depth determines the depth of the frequencies that are filtered for the notch filter frequency. The depth of the notch changes with the notch filter depth. The smaller the notch filter depth is, the deeper the notch is, increasing the effect of vibration suppression. However, if the value is too small, vibration can actually increase.

The notch filter is disabled if the notch filter depth, d , is set to 1.0 (i.e., if Pn419 is set to 1,000).

The notch filter frequency characteristics for different notch filter depths are shown below.

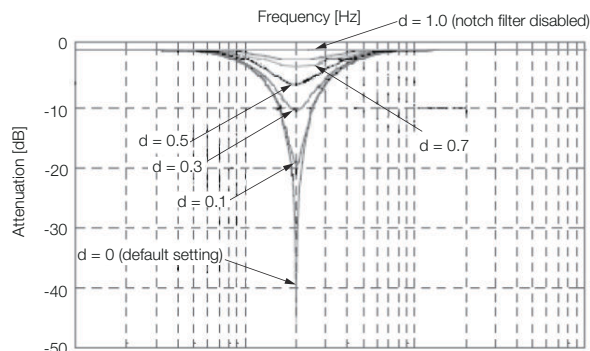


Fig. 303: Notch Filter Frequency Characteristics - Filter Depth



The above notch filter frequency characteristics are based on calculated values and may be different from actual characteristics.

You can enable or disable the notch filter with Pn408 and Pn416.

Parameter		Function	When Enabled	Classification
Pn408	n.□□□0 (default setting)	Disable first stage notch filter.	Immediately	Setup
	n.□□□1	Enable first stage notch filter.		
	n.□0□□ (default setting)	Disable second stage notch filter.		
	n.□1□□	Enable second stage notch filter.		
Pn416	n.□□□0 (default setting)	Disable third stage notch filter.		
	n.□□□1	Enable third stage notch filter.		
	n.□□0□ (default setting)	Disable fourth stage notch filter.		
	n.□□1□	Enable fourth stage notch filter.		
	n.□0□□ (default setting)	Disable fifth stage notch filter.		
	n.□1□□	Enable fifth stage notch filter.		

Set the machine vibration frequencies in the notch filter parameters.

First Stage Notch Filter Frequency

	Setting Range	Setting Unit	Default Setting	When Enabled	Classification
Pn409	50 to 5,000	1 Hz	5,000	Immediately	Tuning

(applies to Speed Control, Position Control and Torque Control)

First Stage Notch Filter Q Value

	Setting Range	Setting Unit	Default Setting	When Enabled	Classification
Pn40A	50 to 1,000	0.01	70	Immediately	Tuning

(applies to Speed Control, Position Control and Torque Control)

First Stage Notch Filter Depth

	Setting Range	Setting Unit	Default Setting	When Enabled	Classification
Pn40B	0 to 1,000	0.001	0	Immediately	Tuning

(applies to Speed Control, Position Control and Torque Control)

Second Stage Notch Filter Frequency

	Setting Range	Setting Unit	Default Setting	When Enabled	Classification
Pn40C	50 to 5,000	1 Hz	5,000	Immediately	Tuning

(applies to Speed Control, Position Control and Torque Control)

Second Stage Notch Filter Q Value

	Setting Range	Setting Unit	Default Setting	When Enabled	Classification
Pn40D	50 to 1,000	0.01	70	Immediately	Tuning

(applies to Speed Control, Position Control and Torque Control)

Second Stage Notch Filter Depth

	Setting Range	Setting Unit	Default Setting	When Enabled	Classification
Pn40E	0 to 1,000	0.001	0	Immediately	Tuning

(applies to Speed Control, Position Control and Torque Control)

Third Stage Notch Filter Frequency

	Setting Range	Setting Unit	Default Setting	When Enabled	Classification
Pn417	50 to 5,000	1 Hz	5,000	Immediately	Tuning

(applies to Speed Control, Position Control and Torque Control)

Third Stage Notch Filter Q Value

	Setting Range	Setting Unit	Default Setting	When Enabled	Classification
Pn418	50 to 1,000	0.01	70	Immediately	Tuning

(applies to Speed Control, Position Control and Torque Control)

Third Stage Notch Filter Depth

	Setting Range	Setting Unit	Default Setting	When Enabled	Classification
Pn419	0 to 1,000	0.001	0	Immediately	Tuning

(applies to Speed Control, Position Control and Torque Control)

Fourth Stage Notch Filter Frequency

	Setting Range	Setting Unit	Default Setting	When Enabled	Classification
Pn41A	50 to 5,000	1 Hz	5,000	Immediately	Tuning

(applies to Speed Control, Position Control and Torque Control)

Fourth Stage Notch Filter Q Value

	Setting Range	Setting Unit	Default Setting	When Enabled	Classification
Pn41B	50 to 1,000	0.01	70	Immediately	Tuning

(applies to Speed Control, Position Control and Torque Control)

Fourth Stage Notch Filter Depth

	Setting Range	Setting Unit	Default Setting	When Enabled	Classification
Pn41C	0 to 1,000	0.001	0	Immediately	Tuning

(applies to Speed Control, Position Control and Torque Control)

Fifth Stage Notch Filter Frequency

	Setting Range	Setting Unit	Default Setting	When Enabled	Classification
Pn41D	50 to 5,000	1 Hz	5,000	Immediately	Tuning

(applies to Speed Control, Position Control and Torque Control)

Fifth Stage Notch Filter Q Value

	Setting Range	Setting Unit	Default Setting	When Enabled	Classification
Pn41E	50 to 1,000	0.01	70	Immediately	Tuning

(applies to Speed Control, Position Control and Torque Control)

Fifth Stage Notch Filter Depth

	Setting Range	Setting Unit	Default Setting	When Enabled	Classification
Pn41F	0 to 1,000	0.001	0	Immediately	Tuning

(applies to Speed Control, Position Control and Torque Control)



- Do not set notch filter frequencies (Pn409, Pn40C, Pn417, Pn41A, and Pn41D) that are close to the speed loop's response frequency. Set a frequency that is at least four times the speed loop gain (Pn100). (However, Pn103 (Moment of Inertia Ratio) must be set to an appropriate value.) If the setting is not correct, vibration may occur and the machine may be damaged.
- Change the notch filter frequencies (Pn409, Pn40C, Pn417, Pn41A, and Pn41D) only while the Servomotor is stopped. Vibration may occur if a notch filter frequency is changed during operation.

Guidelines for Manually Tuning Servo Gains

When you manually adjust the parameters, make sure that you completely understand the information in the product manual and use the following conditional expressions as guidelines.

The appropriate values of the parameter settings are influenced by the machine specifications, so they cannot be determined universally. When you adjust the parameters, actually operate the machine and use the SigmaWin+ or analog monitor to monitor operating conditions. Even if the status is stable while the Servomotor is stopped, an unstable condition may occur when an operation reference is input. Therefore, input operation references and adjust the servo gains as you operate the Servomotor.

Stable gain: Settings that provide a good balance between parameters.

However, if the load moment of inertia is large and the machine system contains elements prone to vibration, you must sometimes use a setting that is somewhat higher to prevent the machine from vibrating.

Critical gain: Settings for which the parameters affect each other

Depending on the machine conditions, overshooting and vibration may occur and operation may not be stable. If the critical gain condition expressions are not met, operation will become more unstable, and there is a risk of abnormal motor shaft vibration and round-trip operation with a large amplitude. Always stay within the critical gain conditions.

If you use the torque reference filter, second torque reference filter, and notch filters together, the interference between the filters and the speed loop gain will be superimposed. Allow leeway in the adjustments.



The following adjusted value guidelines require that the setting of Pn103 (Moment of Inertia Ratio) is correctly set for the actual machine.

- When Pn10B = n.□□0□ (PI Control)
 - Guidelines are given below for gain settings 1.
 - The same guidelines apply to gain settings 2 (Pn104, Pn105, Pn106, and Pn412).
 - Speed Loop Gain (Pn100 [Hz]) and Position Loop Gain (Pn102 [/s])
 - Stable gain: $Pn102 [s] \leq 2\pi \times Pn100/4 [Hz]$
 - Critical gain: $Pn102 [s] \leq 2\pi \times Pn100 [Hz]$
 - Speed Loop Gain (Pn100 [Hz]) and Speed Loop Integral Time Constant (Pn101 [ms])
 - Stable gain: $Pn101 [ms] \geq 4,000/(2\pi \times Pn100 [Hz])$
 - Critical gain: $Pn101 [ms] > 1,000/(2\pi \times Pn100 [Hz])$
 - Speed Loop Gain (Pn100 [Hz]) and First Stage First Torque Reference Filter Time Constant (Pn401 [ms])
 - Stable gain: $Pn401 [ms] \leq 1,000/(2\pi \times Pn100 [Hz] \times 4)$
 - Critical gain: $Pn401 [ms] \leq 1,000/(2\pi \times Pn100 [Hz] \times 1)$
 - Speed Loop Gain (Pn100 [Hz]) and Second Stage Second Torque Reference Filter Frequency (Pn40F [Hz])
 - Critical gain: $Pn40F [Hz] > 4 \times Pn100 [Hz]$
 - Note: Set the second stage second torque reference filter Q value (Pn410) to 0.70.
 - Speed Loop Gain (Pn100 [Hz]) and First Stage Notch Filter Frequency (Pn409 [Hz]) (or Second Stage Notch Filter Frequency (Pn40C [Hz]))
 - Critical gain: $Pn409 [Hz] > 4 \times Pn100 [Hz]$
 - Speed Loop Gain (Pn100 [Hz]) and Speed Feedback Filter Time Constant (Pn308 [ms])
 - Stable gain: $Pn308 [ms] \leq 1,000/(2\pi \times Pn100 [Hz] \times 4)$
 - Critical gain: $Pn308 [ms] \leq 1,000/(2\pi \times Pn100 [Hz] \times 1)$
- When Pn10B = n.□□1□ (I-P Control)
 - Guidelines are given below for gain settings 1.
 - The same guidelines apply to gain settings 2 (Pn104, Pn105, Pn106, and Pn412).
 - For I-P control, the relationships between the speed loop integral time constant, speed loop gain, and position loop gain are different from the relationships for PI control. The relationship between other servo gains is the same as for PI control.
 - Speed Loop Gain (Pn100 [Hz]) and Speed Loop Integral Time Constant (Pn101 [ms])
 - Stable gain: $Pn100 [Hz] \geq 320/Pn101 [ms]$
 - Position Loop Gain (Pn102 [/s]) and Speed Loop Integral Time Constant (Pn101 [ms])

Stable gain: $Pn102 [s] \leq 320/Pn101 [ms]$



Selecting the Speed Loop Control Method (PI Control or I-P Control)

Usually, I-P control is effective for high-speed positioning and high-speed, high-precision processing applications. With I-P control, you can use a lower position loop gain than for PI control to reduce the positioning time and reduce arc radius reduction. However, if you can use mode switching to change to proportional control to achieve the desired application, then using PI control would be the normal choice.

■ **Decimal Points in Parameter Settings**

For the SGD7S SERVOPACKs, decimal places are given for the settings of parameters on the Digital Operator, Panel Operator, and in the manual. For example with Speed Loop Gain (Pn100), Pn100 = 40.0 is used to indicate a setting of 40.0 Hz. In the following adjusted value guidelines, the decimal places are also given.

Example

Speed Loop Gain (Pn100 [Hz]) and Speed Loop Integral Time Constant (Pn101 [ms])

Stable gain: $Pn101 [ms] \geq 4,000/(2\pi \times Pn100 [Hz])$, therefore

If Pn100 = 40.0 [Hz], then $Pn101 = 4,000/(2\pi \times 40.0) \approx 15.92 [ms]$.

Model Following Control

You can use model following control to improve response characteristic and shorten positioning time. You can use model following control only with position control.

Normally, the parameters that are used for model following control are automatically set along with the servo gains by executing autotuning or custom tuning. However, you must adjust them manually in the following cases.

- When the tuning results for autotuning or custom tuning are not acceptable
- When you want to increase the response characteristic higher than that achieved by the tuning results for autotuning or custom tuning
- When you want to determine the servo gains and model following control parameters yourself

The block diagram for model following control is provided below.

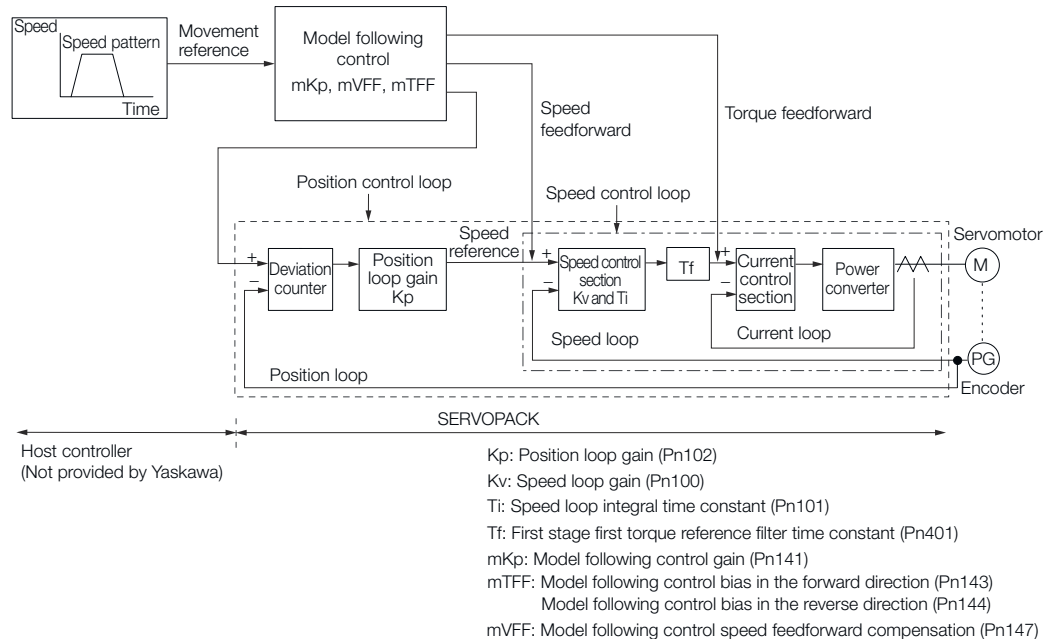


Fig. 304: Model Following Control

■ **Manual Tuning Procedure**

Use the following tuning procedure for using model following control.

Step	Description
1	Friction compensation must also be used. Set the friction compensation parameters. Refer to the following section for the setting procedure. → Chap. 9.13.3 'Friction Compensation' ...page 374
2	Adjust the servo gains. Refer to the following section for an example procedure. → 'Adjusted Servo Gains' ...page 386 Note: 1. Set the moment of inertia ratio (Pn103) as accurately as possible. 2. Refer to the guidelines for manually tuning the servo gains and set a stable gain for the position loop gain (Pn102). → 'Guidelines for Manually Tuning Servo Gains' ...page 392
3	Increase the model following control gain (Pn141) as much as possible within the range in which overshooting and vibration do not occur.
4	If overshooting occurs or if the response is different for forward and reverse operation, fine-tune model following control with the following settings: model following control bias in the forward direction (Pn143), model following control bias in the reverse direction (Pn144), and model following control speed feedforward compensation (Pn147).

■ Related Parameters

Next we will describe the following parameters that are used for model following control.

- Pn140 (Model Following Control-Related Selections)
- Pn141 (Model Following Control Gain)
- Pn143 (Model Following Control Bias in the Forward Direction)
- Pn144 (Model Following Control Bias in the Reverse Direction)
- Pn147 (Model Following Control Speed Feedforward Compensation)

■ Model Following Control-Related Selections

Set Pn140 = n.□□□X to specify whether to use model following control.

If you use model following control with vibration suppression, set Pn140 to n.□□1□ or Pn140 = n.□□2□. When you also perform vibration suppression, adjust vibration suppression with custom tuning in advance.

Note: If you use vibration suppression (Pn140 = n.□□1□ or Pn140 = n.□□2□), always set Pn140 to n.□□□1 (Use model following control).

Parameter	Function	When Enabled	Classification
Pn140	n.□□□0 (default setting)	Immediately	Tuning
	n.□□□1		
	n.□□0□ (default setting)		
	n.□□1□		

Parameter	Function	When Enabled	Classification
n.□□2□	Perform vibration suppression for two specific frequencies.		

■ Model Following Control Gain

The model following control gain determines the response characteristic of the Servo System. If you increase the setting of the model following control gain, the response characteristic will improve and the positioning time will be shortened. The response characteristic of the Servo System is determined by this parameter, and not by Pn102 (Position Loop Gain).

Model Following Control Gain

	Setting Range	Setting Unit	Default Setting	When Enabled	Classification
Pn141	10 to 20,000	0.1/s	500	Immediately	Tuning

(applies to Position Control)



For machines for which a high model following control gain cannot be set, the size of the position deviation in model following control will be determined by the setting of the model following control gain. For a machine with low rigidity, in which a high model following control gain cannot be set, position deviation overflow alarms may occur during high-speed operation. If that is the case, you can increase the setting of the following parameter to increase the level for alarm detection.

Use the following conditional expression for reference in determining the setting.

$$Pn\ 520 \geq \frac{\text{Maximum feed speed [reference units/s]}}{Pn\ 141/10 [1/s]} \times 2.0$$

Fig. 305: Pn520 (Position Deviation Overflow Alarm Level) setting (Model Following Control)

Position Deviation Overflow Alarm Level

	Setting Range	Setting Unit	Default Setting	When Enabled	Classification
Pn520	1 to 1,073,741,823	1 reference unit	5,242,880	Immediately	Setup

(applies to Position Control)

■ Model Following Control Bias in the Forward Direction and Model Following Control Bias in the Reverse Direction

If the response is different for forward and reverse operation, use the following parameters for fine-tuning.

If you decrease the settings, the response characteristic will be lowered but overshooting will be less likely to occur.

Model Following Control Bias in the Forward Direction

	Setting Range	Setting Unit	Default Setting	When Enabled	Classification
Pn143	0 to 10,000	0.1%	1,000	Immediately	Tuning

(applies to Position Control)

Model Following Control Bias in the Reverse Direction

	Setting Range	Setting Unit	Default Setting	When Enabled	Classification
Pn144	0 to 10,000	0.1%	1,000	Immediately	Tuning

(applies to Position Control)

- **Model Following Control Speed Feedforward Compensation**

If overshooting occurs even after you adjust the model following control gain, model following control bias in the forward direction, and model following control bias in the reverse direction, you may be able to improve performance by setting the following parameter.

If you decrease the settings, the response characteristic will be lowered but overshooting will be less likely to occur.

Model Following Control Speed Feedforward Compensation

	Setting Range	Setting Unit	Default Setting	When Enabled	Classification
Pn147	0 to 10,000	0.1%	1,000	Immediately	Tuning

(applies to Position Control)

- **Model Following Control Type Selection**

When you enable model following control, you can select the model following control type. Normally, set Pn14F to n.□□□1 (Use model following control type 2) (default setting). If compatibility with previous models is required, set Pn14F to n.□□□0 (Use model following control type 1).

Parameter		Function	When Enabled	Classification
Pn14F	n.□□□0	Use model following control type 1.	After restart	Tuning
	n.□□□1 After restart Tuning (default setting)	Use model following control type 2.		

9.14.3 Compatible Adjustment Functions

The compatible adjustment functions are used together with manual tuning. You can use these functions to improve adjustment results. These functions allow you to use the same functions as for Σ -III-Series SERVOPACKs to adjust Σ -7-Series SERVOPACKs.

Feedforward

The feedforward function applies feedforward compensation to position control to shorten the positioning time.

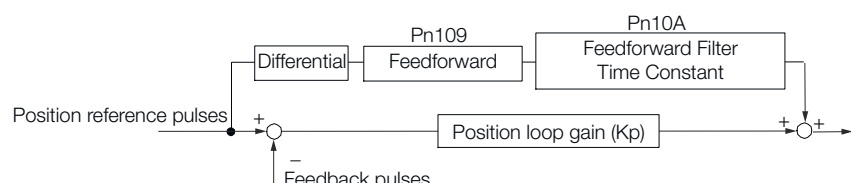


Fig. 306: Feedforward Function

Feedforward

	Setting Range	Setting Unit	Default Setting	When Enabled	Classification
Pn109	0 to 100	1%	0	Immediately	Tuning

(applies to Position Control)

Feedforward Filter Time Constant

	Setting Range	Setting Unit	Default Setting	When Enabled	Classification
Pn10A	0 to 6,400	0.01 ms	0	Immediately	Tuning

(applies to Position Control)

Note: If you set the feedforward value too high, the machine may vibrate. As a guideline, use a setting of 80% or less.

Mode Switching (Changing between Proportional and PI Control)

You can use mode switching to automatically change between proportional control and PI control.

Overshooting caused by acceleration and deceleration can be suppressed and the settling time can be reduced by setting the switching condition and switching levels.

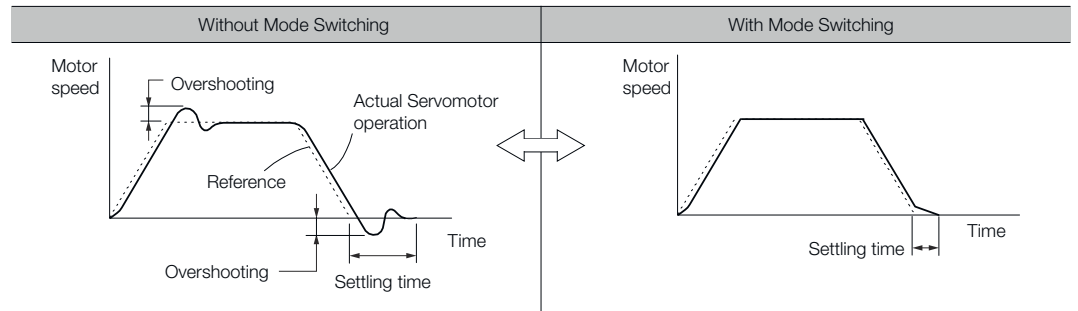


Fig. 307: Mode Switching

■ Related Parameters

Select the switching condition for mode switching with Pn10B = n.□□□X.

Parameter	Mode Switching Selection	Parameter That Sets the Level		When Enabled	Classification
		Rotary Servomotor	Linear Servomotor		
Pn10B	n.□□ □0 (default setting)	Use the internal torque reference as the condition.		Immediately	Setup
	n.□□ □1	Pn10D	Pn181		
	n.□□ □2	Pn10E	Pn182		
	n.□□ □3	Pn10F			

Parameter	Mode Switching Selection	Parameter That Sets the Level		When Enabled	Classification
		Rotary Servomotor	Linear Servomotor		
n.□□ □4	Do not use mode switching.	-			

Parameters That Set the Switching Levels

■ Rotary Servomotors

Mode Switching Level for Torque Reference

	Setting Range	Setting Unit	Default Setting	When Enabled	Classification
Pn10C	0 to 800	1%	200	Immediately	Tuning

(applies to Speed Control and Position Control)

Mode Switching Level for Speed Reference

	Setting Range	Setting Unit	Default Setting	When Enabled	Classification
Pn10D	0 to 10,000	1 min ⁻¹	0	Immediately	Tuning

(applies to Speed Control and Position Control)

Mode Switching Level for Acceleration

	Setting Range	Setting Unit	Default Setting	When Enabled	Classification
Pn10E	0 to 30,000	1 min ⁻¹ /s	0	Immediately	Tuning

(applies to Speed Control and Position Control)

Mode Switching Level for Position Deviation

	Setting Range	Setting Unit	Default Setting	When Enabled	Classification
Pn10F	0 to 10,000	1 reference unit	0	Immediately	Tuning

(applies to Position Control)

■ Linear Servomotors

Mode Switching Level for Force Reference

	Setting Range	Setting Unit	Default Setting	When Enabled	Classification
Pn10C	0 to 800	1%	200	Immediately	Tuning

(applies to Speed Control and Position Control)

Mode Switching Level for Speed Reference

	Setting Range	Setting Unit	Default Setting	When Enabled	Classification
Pn181	0 to 10,000	1 mm/s	0	Immediately	Tuning

(applies to Speed Control and Position Control)

Mode Switching Level for Acceleration

	Setting Range	Setting Unit	Default Setting	When Enabled	Classification
Pn182	0 to 30,000	1 mm/s ²	0	Immediately	Tuning

(applies to Speed Control and Position Control)

Mode Switching Level for Position Deviation

	Setting Range	Setting Unit	Default Setting	When Enabled	Classification
Pn10F	0 to 10,000	1 reference unit	0	Immediately	Tuning

(applies to Position Control)

Using the Internal Torque Reference as the Mode Switching Condition (Default Setting)

When the Internal torque reference equals or exceeds the torque set for the mode switching level for torque reference (Pn10C), the speed loop is changed to P control.

The default setting for the torque reference level is 200%.

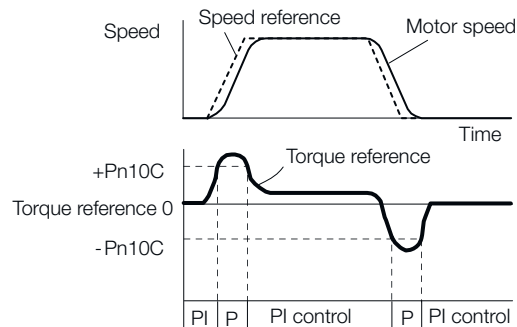


Fig. 308: Torque Reference as the Mode Switching Condition

Using the Speed Reference as the Mode Switching Condition

■ Rotary Servomotors

When the speed reference equals or exceeds the speed set for the mode switching level for a speed reference (Pn10D), the speed loop is changed to P control.

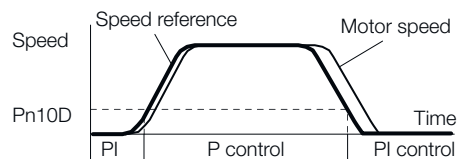


Fig. 309: Speed Reference as the Mode Switching Condition - Rotary

■ Linear Servomotors

When the speed reference equals or exceeds the speed set for the mode switching level for a speed reference (Pn181), the speed loop is changed to P control.

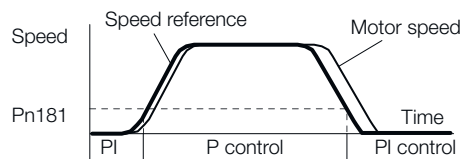


Fig. 310: Speed Reference as the Mode Switching Condition - Linear

Using the Acceleration as the Mode Switching Condition

■ Rotary Servomotors

When the speed reference equals or exceeds the acceleration rate set for the mode switching level for acceleration (Pn10E), the speed loop is changed to P control.

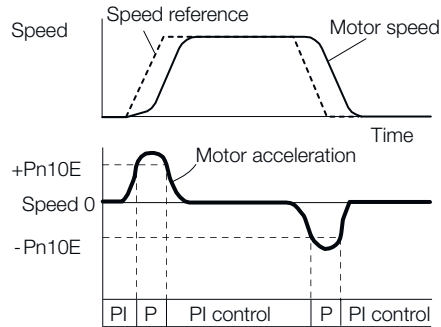


Fig. 311: Acceleration as the Mode Switching Condition - Rotary

■ Linear Servomotors

When the speed reference equals or exceeds the acceleration rate set for the mode switching level for acceleration (Pn182), the speed loop is changed to P control.

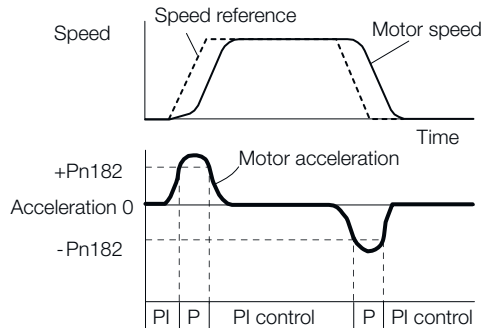


Fig. 312: Acceleration as the Mode Switching Condition - Linear

Using the Position Deviation as the Mode Switching Condition

When the position deviation equals or exceeds the value set for the mode switching level for position deviation (Pn10F), the speed loop is changed to P control.

This setting is enabled only for position control.

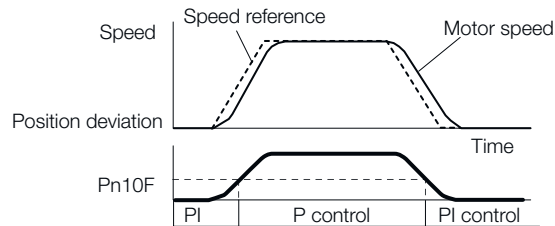


Fig. 313: Position Deviation as the Mode Switching Condition

Position Integral

The position integral is the integral function of the position loop. This parameter is effective for electronic cams and electronic shafts.

Position Integral Time Constant

	Setting Range	Setting Unit	Default Setting	When Enabled	Classification
Pn11F	0 to 50,000	0.1 ms	0	Immediately	Tuning

(applies to Position Control)

9.15 Diagnostic Tools

9.15.1 Mechanical Analysis

Overview

You can connect the SERVOPACK to a computer to measure the frequency characteristics of the machine. This allows you to measure the frequency characteristics of the machine without using a measuring instrument.

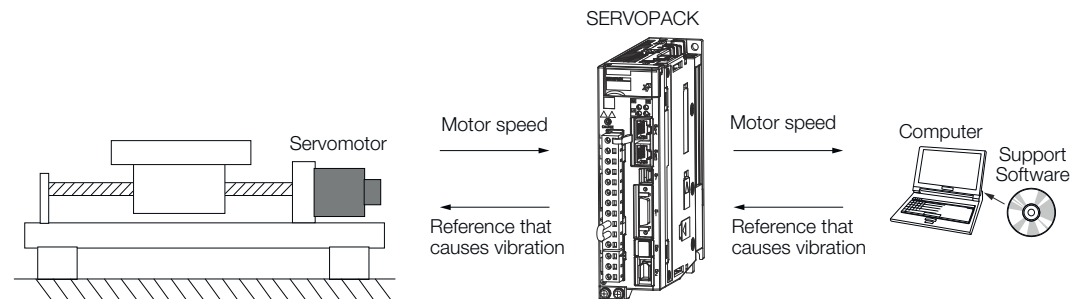


Fig. 314: Mechanical Analysis

The Servomotor is used to cause machine vibration and then the speed frequency characteristics for the motor torque are measured. The measured frequency characteristics can be used to determine the machine resonance.

You determine the machine resonance for use in servo tuning and as reference for considering changes to the machine. The performance of the servo cannot be completely utilized depending on the rigidity of the machine. You may need to consider making changes to the machine. The information can also be used as reference for servo tuning to help you adjust parameters, such as the servo rigidity and torque filter time constant.

You can also use the information to set parameters, such as the notch filters.



WARNING

Mechanical analysis requires operating the Servomotor and therefore presents hazards. Before you execute mechanical analysis, check the information provided in the SigmaWin+ operating manual.

Frequency Characteristics

The Servomotor is used to cause the machine to vibrate and the frequency characteristics from the torque to the motor speed are measured to determine the machine characteristics. For a normal machine, the resonance frequencies are clear when the frequency characteristics are plotted on graphs with the gain and phase (Bode plots). The Bode plots show the size (gain) of the response of the machine to which the torque is applied, and the phase delay (phase) in the response for each frequency. Also, the machine resonance frequency can be determined from the maximum frequency of the valleys (anti-resonance) and peaks (resonance) of the gain and the phase delay.

For a Servomotor without a load or for a rigid mechanism, the gain and phase change gradually in the Bode plots.

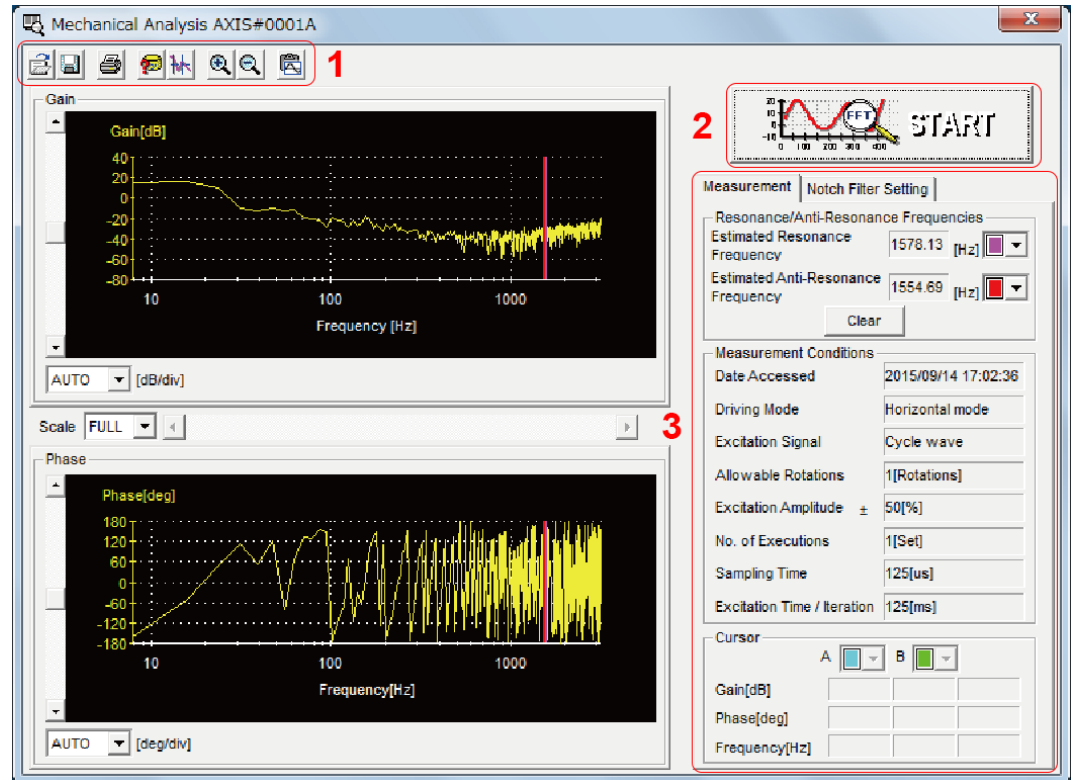


Fig. 315: Mechanical Analysis - Frequency Characteristics

1 - Toolbar

2 - **START** Button

Click the **START** Button to start analysis.

3 - **Measurement** and **Notch Filter Setting** Tab Pages

Measurement Tab Page: Displays detailed information on the results of analysis.

Notch Filter Setting Tab Page: Displays the notch filter frequencies. You can set these values in the parameters.

9.15.2 Easy FFT

The machine is made to vibrate and a resonance frequency is detected from the generated vibration to set notch filters according to the detected resonance frequencies. This is used to eliminate high-frequency vibration and noise.

During execution of Easy FFT, a frequency waveform reference is sent from the SERVOPACK to the Servomotor to automatically cause the shaft to rotate multiple times within 1/4th of a rotation, thus causing the machine to vibrate.

Execute Easy FFT after the servo is turned OFF if operation of the SERVOPACK results in highfrequency noise and vibration.



WARNING

Never touch the Servomotor or machine during execution of Easy FFT. Doing so may result in injury.



CAUTION

Use Easy FFT when the servo gain is low, such as in the initial stage of servo tuning. If you execute Easy FFT after you increase the gain, the machine may vibrate depending on the machine characteristics or gain balance.

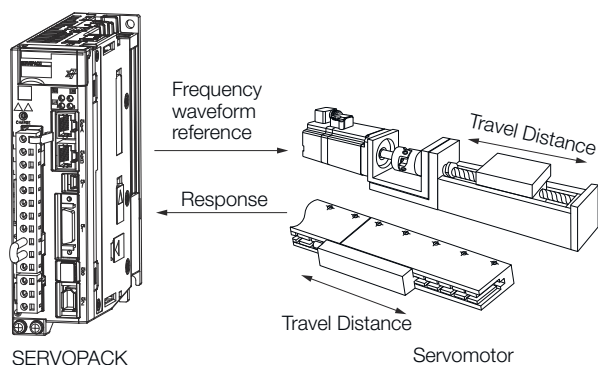


Fig. 316: Easy FFT - Frequency Waveform Reference

Easy FFT is built into the SERVOPACK for compatibility with previous products. Normally use autotuning without a host reference for tuning.


Preparations

Check the following settings before you execute Easy FFT.

- The parameters must not be write prohibited.
- The main circuit power supply must be ON.
- The test without a motor function must be disabled (Pn00C = n.□□□0).
- There must be no alarms.
- There must be no hard wire base block (HWBB).
- The servo must be OFF.
- There must be no overtravel.
- An external reference must not be input.

Operating Procedure

Use the following procedure for Easy FFT.

1. Click the  Servo Drive Button in the workspace of the Main Window of the SigmaWin+.
2. Select **Easy FFT** in the Menu Dialog Box.
 - ➔ The Easy FFT Dialog Box will be displayed.

Click the **Cancel** Button to cancel Easy FFT. You will return to the main window.

3. → Click the OK Button.

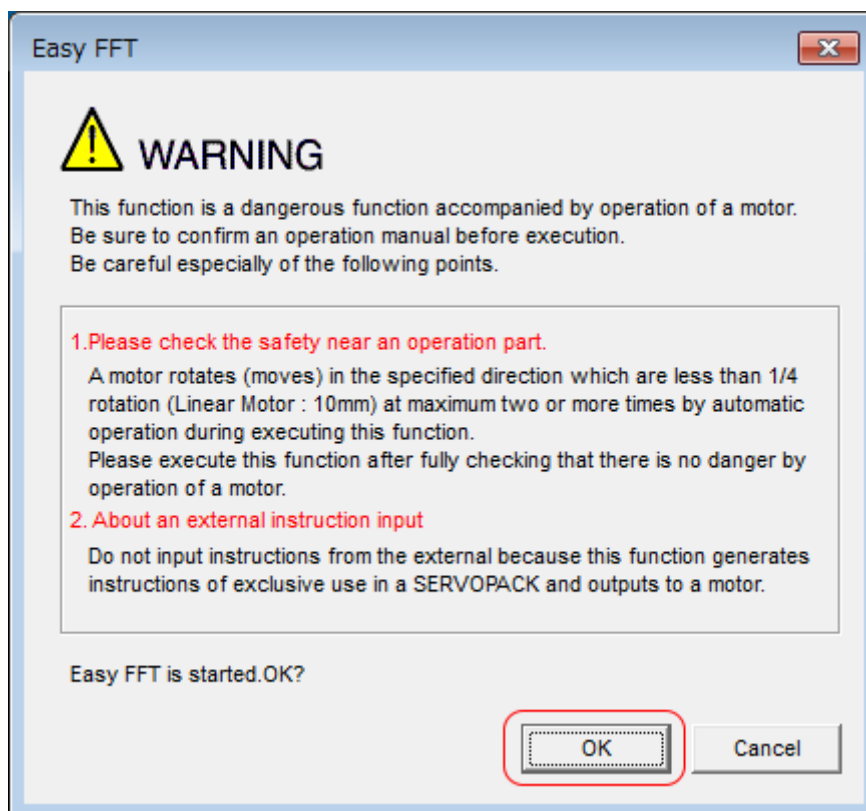


Fig. 317: Easy FFT - Warning

4. → Click the **Servo ON** Button.

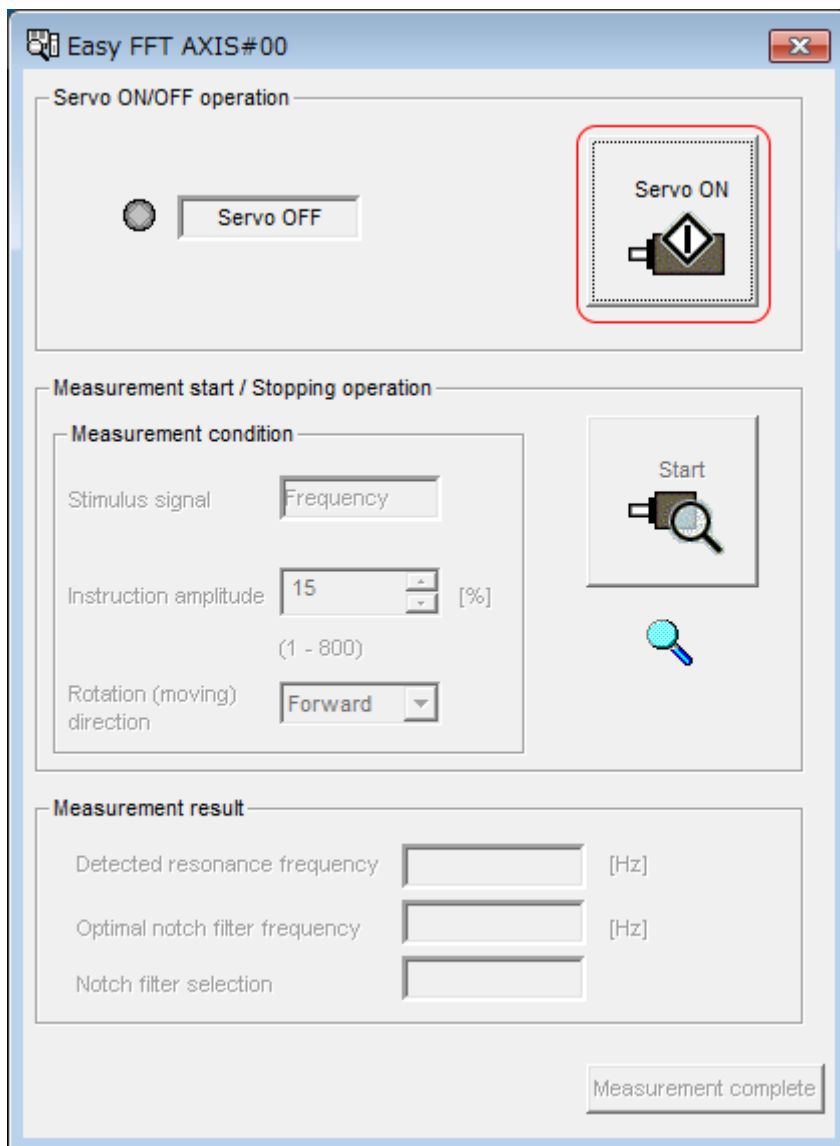


Fig. 318: Easy FFT - Servo ON

5. → Select the instruction (reference) amplitude and the rotation direction in the **Measurement condition** Area, and then click the **Start** Button.
- ➔ The Servomotor shaft will rotate and measurements will start.

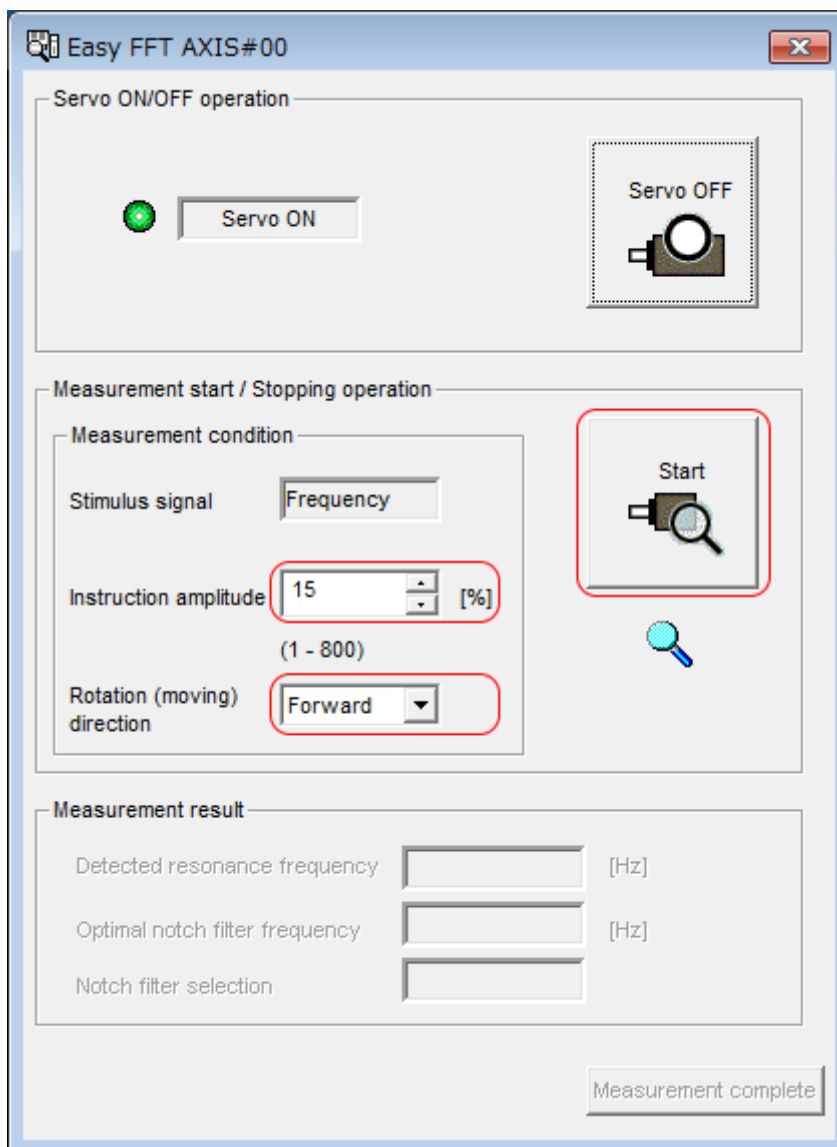


Fig. 319: Easy FFT - Measurement start

When measurements have been completed, the measurement results will be displayed.

6. → Check the results in the **Measurement result** Area and then click the **Measurement complete** Button.

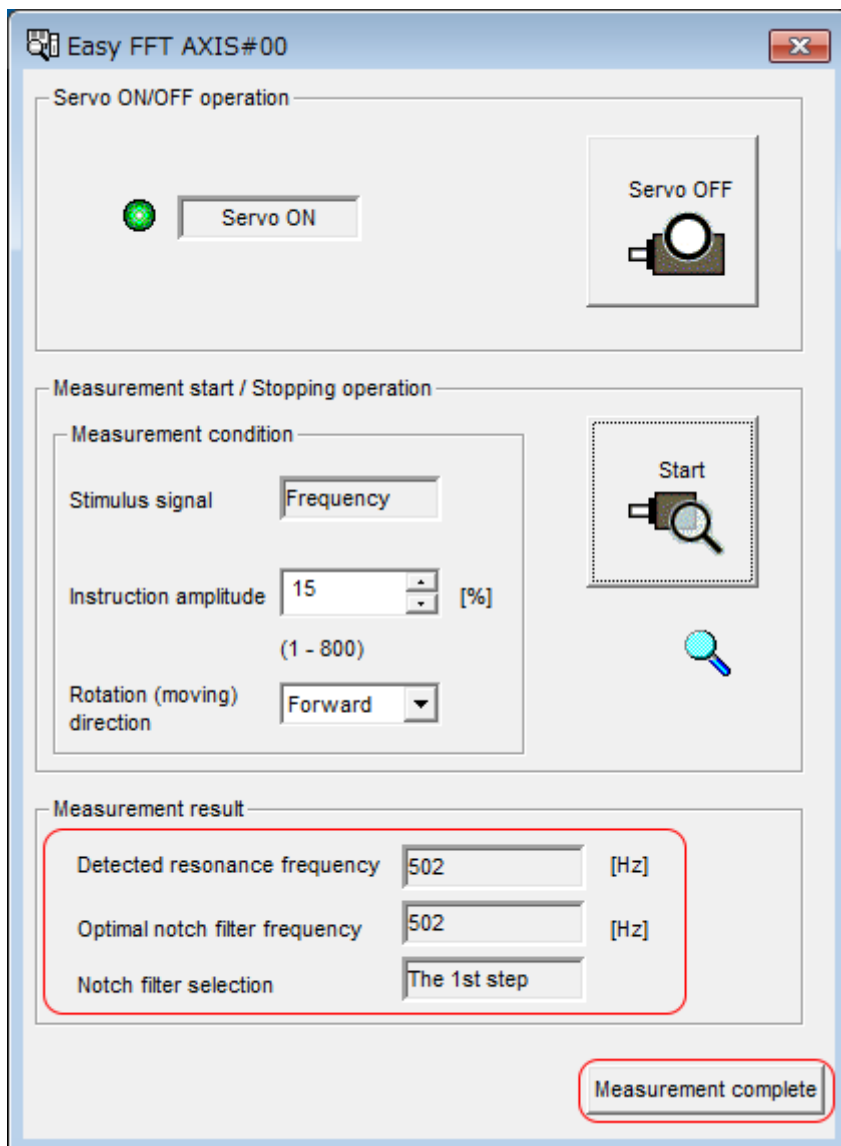


Fig. 320: Easy FFT - Measurement result

7. Click the **Result Writing** Button if you want to set the measurement results in the parameters.

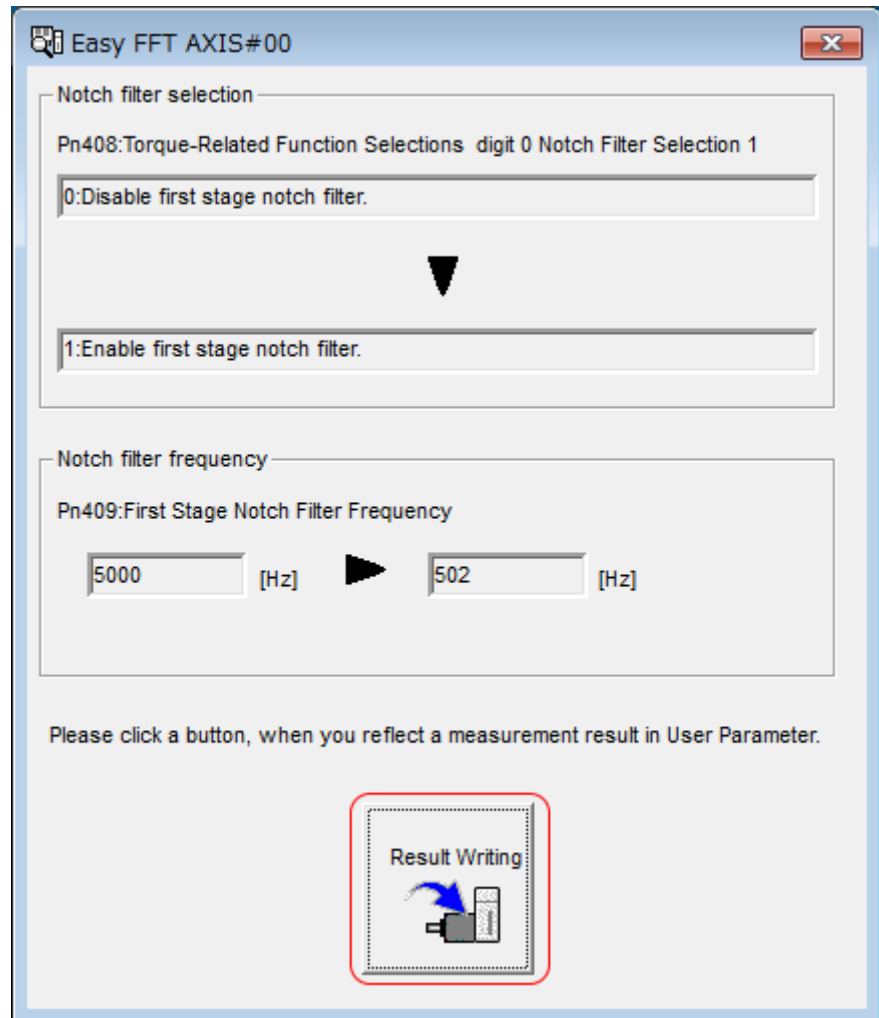


Fig. 321: Easy FFT - Result writing

- ➔ This concludes the procedure to set up Easy FFT.

Related Parameters

The following parameters are automatically adjusted or used as reference when you execute Easy FFT. Do not change the settings of these parameters during execution of Easy FFT.

Parameter	Name	Automatic Changes
Pn408	Torque-Related Function Selections	Yes
Pn409	First Stage Notch Filter Frequency	Yes
Pn40A	First Stage Notch Filter Q Value	No
Pn40C	Second Stage Notch Filter Frequency	Yes
Pn40D	Second Stage Notch Filter Q Value	No
Pn456	Sweep Torque Reference Amplitude	No

Yes: The parameter is automatically set.

No: The parameter is not automatically set, but the setting is read during execution.

10 Monitoring

10.1 Overview

This chapter provides information on monitoring SERVOPACK product information and SERVOPACK status.

10.2 Monitoring Product Information

10.2.1 Items That Can Be Monitored


The items that can be monitored in the SigmaWin+ Product Information Window are listed below.

Monitor Items	
Information on SERVOPACKs	<ul style="list-style-type: none"> ■ Model/Type ■ Serial Number ■ Manufacturing Date ■ Software version (SW Ver.) ■ Remarks
Information on Servomotors	<ul style="list-style-type: none"> ■ Model/Type ■ Serial Number ■ Manufacturing Date ■ Remarks
Information on Encoders	<ul style="list-style-type: none"> ■ Model/Type ■ Serial Number ■ Manufacturing Date ■ Software version (SW Ver.) ■ Remarks
Information on Option Modules	<ul style="list-style-type: none"> ■ Model/Type ■ Serial Number ■ Manufacturing Date ■ Software version (SW Ver.) ■ Remarks

10.2.2 Operating Procedures

Use the following procedure to display the Servo Drive product information.

- Select **Read Product Information** in the Menu Dialog Box of the SigmaWin+. The Read Product Information Window will be displayed.




Product Information					
- 0001-SGD7S-1R6AE0A					
SERVOPACK	Model/Type	Serial Number	Manufacturing Date	SW Ver.	Remarks
SERVOPACK	SGD7S-1R6AE0A (Command-Option module type single)		2015.01	001D	[Specification] : Standard
Motor	Model/Type	Number	Manufacturing Date	SW Ver.	Remarks
1 Motor	SGM7J-02A7A21	20131204	2013.12		[Resolution] : 16777216 [Pulse/rev] [Encoder type] : absolute
Encoder	UTTAI-B24RH		2013.12	0001	
Command Option Module	Model/Type	Serial Number	Manufacturing Date	SW Ver.	Remarks
Option Module	SGDV-OCA03A (INDEXER)	D0146D352110007	2014.06	0006	

Fig. 322: Read Product Information



With the Digital Operator, you can use Fn011, Fn012, and Fn01E to monitor this information. Refer to the following manual for the differences in the monitor items compared with the SigmaWin+.

 *Σ-7-Series Digital Operator Operating Manual (Manual No.: SIEP S800001 33)*

10.3 Monitoring SERVOPACK Status

10.3.1 Servo Drive Status

Use the following procedure to display the Servo Drive status.

- Start the SigmaWin+. The Servo Drive status will be automatically displayed when you go online with a SERVOPACK.

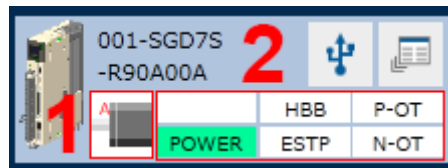


Fig. 323: Servo Drive Status

- The Servomotor type is displayed.
- The Servo Drive status is displayed.

10.3.2 Monitoring Status and Operations

Monitor Items

The items that can be monitored on the Status Monitor Window and Motion Monitor Window are listed below.

Status Monitor Window

Monitor Items		
Internal Status	Input Signal Status	Output Signal Status
<ul style="list-style-type: none"> ■ Polarity Sensor Signal Monitor ■ Active Gain Monitor ■ Main Circuit ■ Encoder (PGRDY) ■ Motor Power (Request) ■ Motor Power ON ■ Dynamic Brake (DB) ■ Rotation (Movement) Direction ■ Mode Switch ■ Speed Reference (V-Ref) ■ Torque Reference (T-Ref) ■ Position Reference (PULS) ■ CLR (Position Deviation Clear Input Signal) ■ Position Reference Direction ■ Surge Current Limiting Resistor Short Relay ■ Regenerative Transistor ■ Regenerative Error Detection ■ AC Power ON ■ Overcurrent ■ Origin Not Passed ■ Moment of Inertia Identification ■ Polarity Detection in Progress ■ Completion of Polarity Detection ■ Ripple Compensation in Progress 	<ul style="list-style-type: none"> ■ P-OT (Forward Drive Prohibit Input Signal) ■ N-OT (Reverse Drive Prohibit Input Signal) ■ /P-CL (Forward External Torque Limit Signal) ■ /N-CL (Reverse External Torque Limit Signal) ■ SEN (Absolute Data Request Input Signal) ■ /SPD-D (Motor Direction Input) Signal ■ /SPD-A (Internal Set Speed Selection Input Signal) ■ /SPD-B (Internal Set Speed Selection Input Signal) ■ /C-SEL (Control Selection Input Signal) ■ /ZCLAMP (Zero Clamping Input Signal) ■ /INHIBIT (Reference Pulse Inhibit Input Signal) ■ /G-SEL (Gain Selection Input Signal) ■ /P-DET (Polarity Detection Input Signal) ■ /DEC (Origin Return Deceleration Switch Input Signal) ■ /EXT1 (External Latch Input 1 Signal) ■ /EXT2 (External Latch Input 2 Signal) ■ /EXT3 (External Latch Input 3 Signal) ■ FSTP (Forced Stop Input Signal) 	<ul style="list-style-type: none"> ■ ALM (Servo Alarm Output Signal) ■ /COIN (Positioning Completion Output Signal) ■ /V-CMP (Speed Coincidence Detection Output Signal) ■ /TGON (Rotation Detection Output Signal) ■ /S-RDY (Servo Ready Output Signal) ■ /CLT (Torque Limit Detection Output Signal) ■ /VLT (Speed Limit Detection Output Signal) ■ /BK (Brake Output Signal) ■ /WARN (Warning Output Signal) ■ /NEAR (Near Output Signal) ■ PAO (Encoder Divided Pulse Output Phase A Signal) ■ PBO (Encoder Divided Pulse Output Phase B Signal) ■ PCO (Encoder Divided Pulse Output Phase C Signal) ■ /PM (Preventative Maintenance Output Signal)

Motion Monitor Window

Monitor Items

- | | |
|--|---|
| ■ Current Alarm State | ■ Target Position (TPOS) |
| ■ Motor Speed | ■ Latched Position 1 (LPOS1) |
| ■ Speed Reference | ■ Latched Position 2 (LPOS2) |
| ■ Internal Torque Reference | ■ Latched Position 3 (LPOS3) |
| ■ Angle of Rotation 1 (number of encoder pulses from origin within one encoder rotation) | ■ Target Speed (TSPD) |
| ■ Angle of Rotation 2 (angle from origin within one encoder rotation) | ■ Feedback Speed (FSPD) |
| ■ Input Reference Pulse Speed | ■ Current Position Command Speed (CSPD) |
| ■ Deviation Counter (Position Deviation) | ■ Torque Limit (TRQ_LIM) |
| ■ Cumulative Load | ■ Speed Limit (SPD_LIM) |
| ■ Regenerative Load | ■ 2312h: Max. Motor Speed |
| ■ DB Resistor Consumption Power | ■ 2313h: Max. Motor Acceleration |
| ■ Absolute Encoder Multiturn Data | ■ 2314h: Max. Motor Torque |
| ■ Absolute Encoder Position within One Rotation | ■ 2401h: Target Position in Range |
| ■ Lower Bits of Absolute Encoder Position | ■ 2402h: Actual Position in Range |
| ■ Upper Bits of Absolute Encoder Position | ■ 2504h: Statusword 2 (ZSW2) |
| ■ Reference Pulse Counter | ■ 2506h: Speed Actual Value A (NIST_A) |
| ■ Feedback Pulse Counter | ■ 2508h: Speed Actual Value B (NIST_B) |
| ■ Fully Closed Feedback Pulse Counter | ■ 2533h: Actual Traversing Block (AKT-SATZ) |
| ■ Total Operating Time | ■ 6041h: Statusword (ZSW1) |
| ■ Current Backlash Compensation Value | ■ 6061h: Modes of Operation Display |
| ■ Backlash Compensation Value Setting Limit | ■ 6062h: Position Demand Value |
| ■ Position Amplifier Deviation | ■ 6063h: Position Actual Internal Value |
| ■ Feedback Position (APOS) | ■ 6064h: Position Actual Value |
| ■ Current Reference Position (CPOS) | ■ 606Bh: Velocity Demand Value |
| ■ Position Deviation (PERR) | ■ 606Ch: Velocity Actual Value |
| | ■ 6074h: Torque Demand Value |
| | ■ 60B9h: Touch Probe Status |
| | ■ 60BAh: Touch Probe 1 Position Value |
| | ■ 60BCh: Touch Probe 2 Position Value |
| | ■ 60F4h: Following Error Actual Value |
| | ■ 60FCh: Position Demand Internal Value |

Operating Procedure

Use the following procedure to display the Motion Monitor and Status Monitor for the SERVOPACK.

- Select **Monitor** in the Menu Dialog Box of the SigmaWin+. The Operation Pane and Status Pane will be displayed in the Monitor Window.

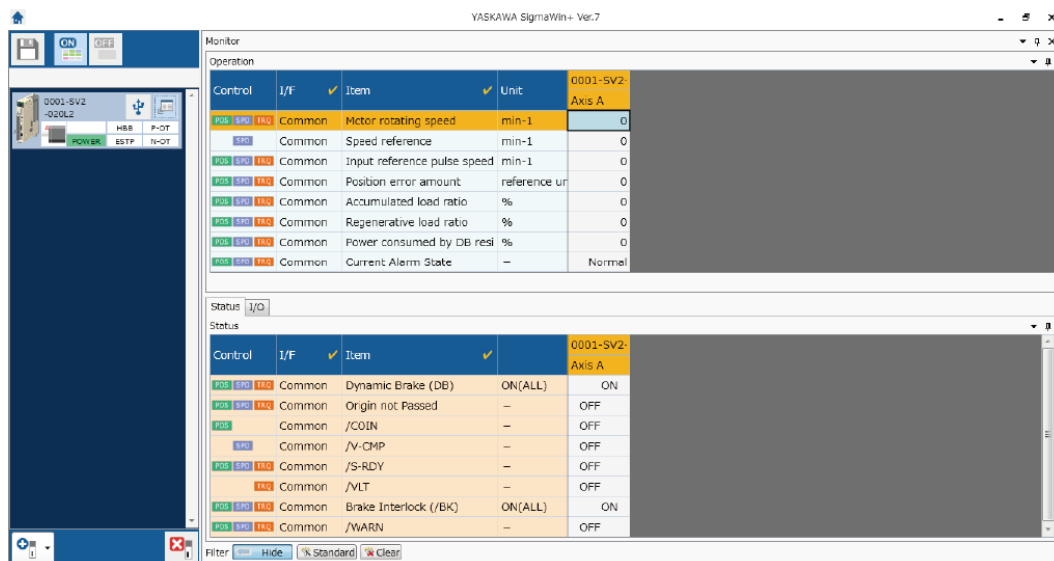


Fig. 324: Monitor



You can flexibly change the contents that are displayed in the Monitor Window. Refer to the following manual for details.

Engineering Tool SigmaWin+ Operation Manual (Manual No.: SIET S80001 34)

10.3.3 I/O Signal Monitor

Use the following procedure to check I/O signals.

1. Click the Servo Drive Button in the workspace of the Main Window of the SigmaWin+.
2. Select **Wiring Check** in the Menu Dialog Box.
 - ➔ The Wiring Check Dialog Box will be displayed.

3. Click the **Monitor Mode** Button.

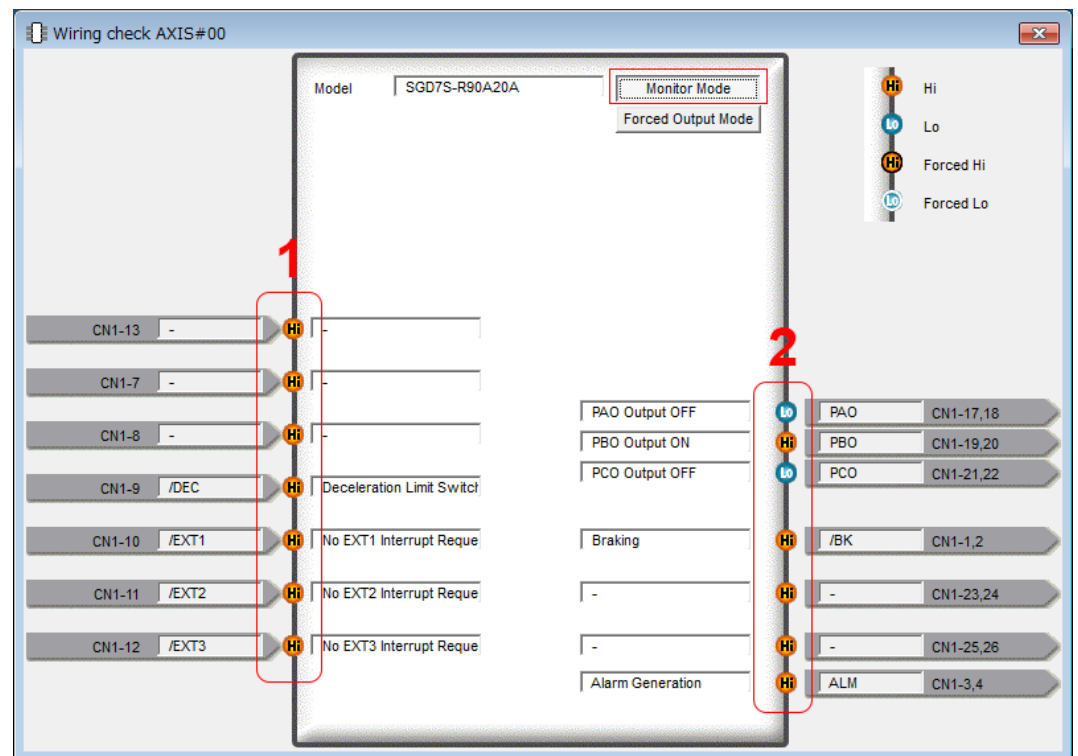


Fig. 325: Wiring Check AXIS#00

- 1 Input signal status
- 2 Output signal status



You can also use the above window to check wiring.

- **Checking Input Signal Wiring**
Change the signal status at the host controller. If the input signal status on the window changes accordingly, then the wiring is correct.
- **Checking Output Signal Wiring**
Click the **Force Output Mode** Button. This will force the output signal status to change. If the signal status at the host controller changes accordingly, then the wiring is correct. You cannot use the **Force Output Mode** Button while the servo is ON.

10.4 Monitoring Machine Operation Status and Signal Waveforms

10.4.1 Overview

To monitor waveforms, use the SigmaWin+ trace function or a measuring instrument, such as a memory recorder.

10.4.2 Items That You Can Monitor

You can use the SigmaWin+ or a measuring instrument to monitor the shaded items in the following block diagram.

Rotary Servomotors

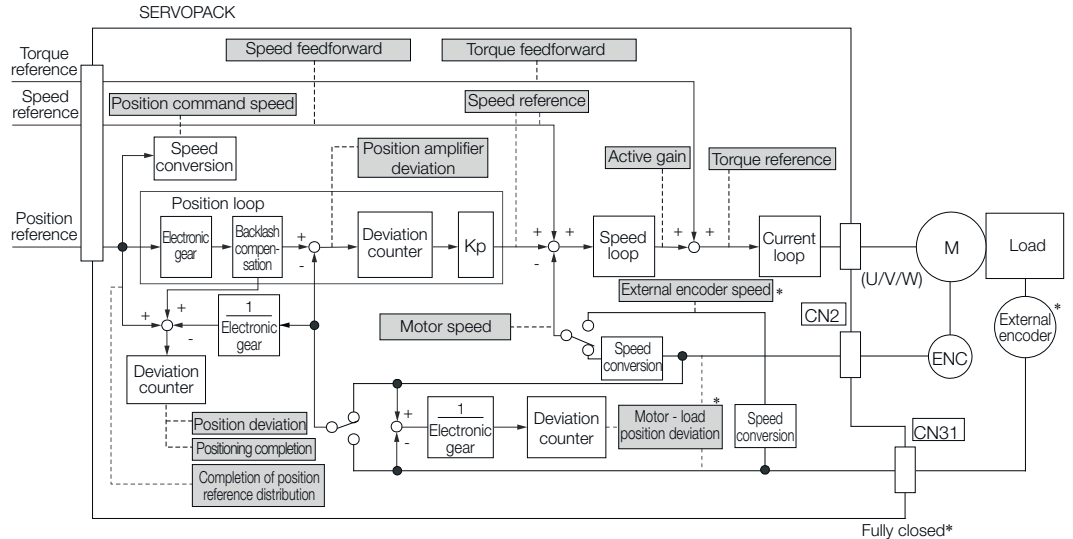


Fig. 326: Items That You Can Monitor - Rotary Servomotors

* This speed is available when fully-closed loop control is being used.

Linear Servomotors

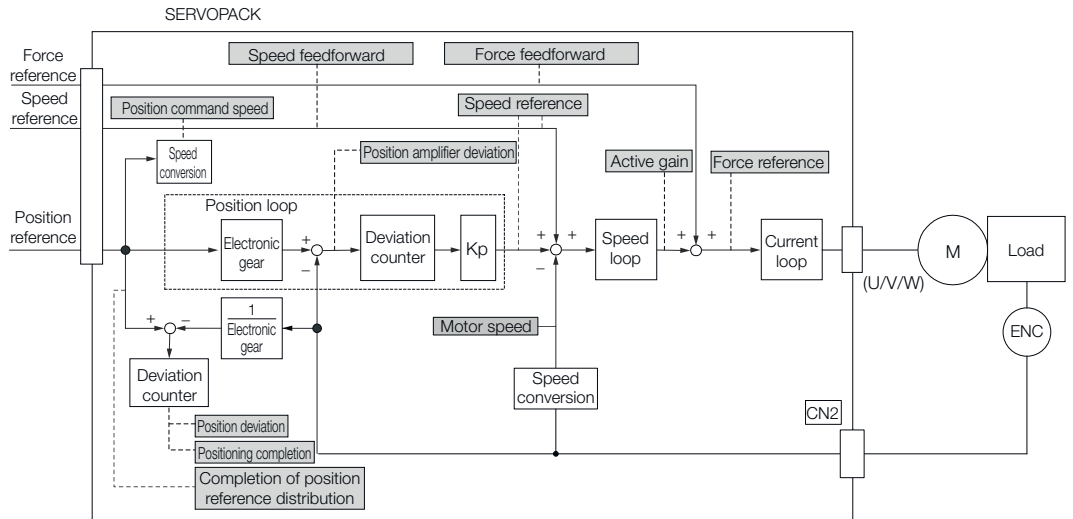


Fig. 327: Items That You Can Monitor - Linear Servomotors

10.4.3 Using the SigmaWin+

This section describes how to trace data and I/O with the SigmaWin+.

Refer to the following manual for detailed operating procedures for the SigmaWin+.

📖 AC Servo Drive Engineering Tool SigmaWin+ Operation Manual (Manual No.: SIET S800001 34)

Operating Procedure

1. ➔ Click the Servo Drive Button in the workspace of the Main Window of the SigmaWin+.
2. ➔ Select **Trace** in the Menu Dialog Box.
 - ➔ The Trace Dialog Box will be displayed.

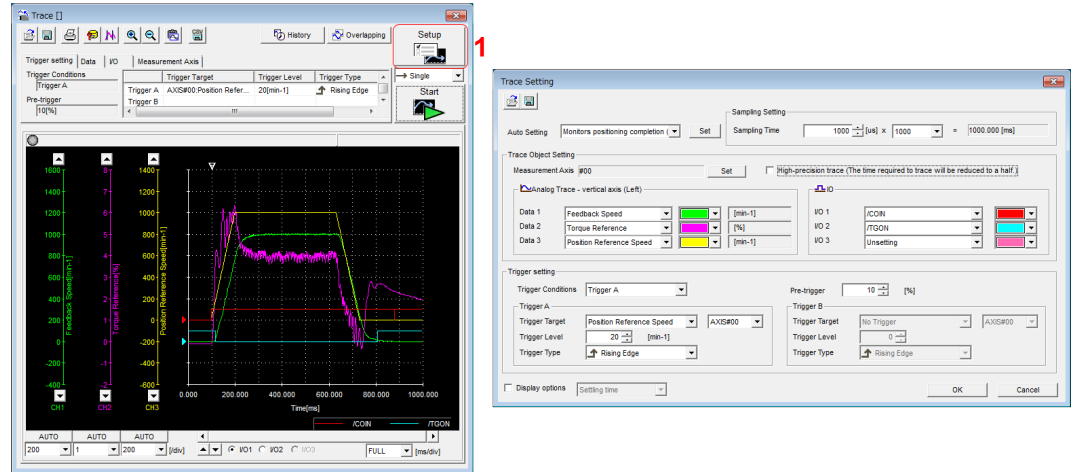


Fig. 328: Trace Setting

- 1 Click this button to display the Trace Setting Dialog Box shown below, and set the data to trace and the trace conditions.

Trace Objects

You can trace the following items.

Data Tracing

Trace Objects

- Torque Reference
- Feedback Speed
- Reference Speed
- Position Reference Speed
- Position Error (Deviation)
- Position Amplifier Error (Deviation)
- Motor - Load Position Deviation
- Speed Feedforward
- Torque Feedforward
- Effective (Active) Gain
- Main Circuit DC Voltage

I/O Tracing

Trace Objects

Input Signals	Output Signals	Internal Status
<ul style="list-style-type: none"> ■ P-OT (Forward Drive Prohibit Input Signal) ■ N-OT (Reverse Drive Prohibit Input Signal) ■ /P-CL (Forward External Torque/Force Limit Input Signal) ■ /N-CL (Reverse External Torque/Force Limit Input Signal) ■ /G-SEL (Gain Selection Input Signal) ■ /P-DET (Polarity Detection Input Signal) ■ /DEC (Origin Return Deceleration Switch Input Signal) ■ /EXT1 (External Latch Input 1 Signal) ■ /EXT2 (External Latch Input 2 Signal) 	<ul style="list-style-type: none"> ■ ALM (Servo Alarm Output Signal) ■ /COIN (Positioning Completion Output Signal) ■ /V-CMP (Speed Coincidence Detection Output Signal) ■ /TGON (Rotation Detection Output Signal) ■ /S-RDY (Servo Ready Output Signal) ■ /CLT (Torque Limit Detection Output Signal) ■ /VLT (Speed Limit Detection Output Signal) ■ /BK (Brake Output Signal) ■ /WARN (Warning Output Signal) ■ /NEAR (Near Output Signal) 	<ul style="list-style-type: none"> ■ ACON (Main Circuit ON Signal) ■ PDETCMP (Polarity Detection Completed Signal) ■ DEN (Position Reference Distribution Completed Signal)

Trace Objects		
Input Signals	Output Signals	Internal Status
<ul style="list-style-type: none"> ■ /EXT3 (External Latch Input 3 Signal) ■ FSTP (Forced Stop Input Signal) ■ /HWBB1 (Hard Wire Base Block Input 1 Signal) ■ /HWBB2 (Hard Wire Base Block Input 2 Signal) 	<ul style="list-style-type: none"> ■ ALO1 (Alarm Code Output Signal) ■ ALO2 (Alarm Code Output Signal) ■ ALO3 (Alarm Code Output Signal) ■ PAO (Encoder Divided Pulse Output Phase A Signal) ■ PBO (Encoder Divided Pulse Output Phase B Signal) ■ PCO (Encoder Divided Pulse Output Phase C Signal) 	

10.4.4 Using the Analog Monitors

Connect a measuring instrument, such as a memory recorder, to the analog monitor connector (CN5) on the SERVOPACK to monitor analog signal waveforms. The measuring instrument is not provided by Yaskawa.

Refer to the following section for details on the connection.

➔ [Chap. 5.9.3 'Analog Monitor Connector \(CN5\)' ...page 126](#)

Setting the Monitor Object

Use Pn006 = n.□□XX and Pn007 = n.□□XX (Analog Monitor 1 and 2 Signal Selections) to set the items to monitor.

Line Color	Signal	Parameter Setting
White	Analog monitor 1	Pn006 = n.□□XX
Red	Analog monitor 2	Pn007 = n.□□XX
Black (2 lines)	GND	–

Parameter		Description		
		Monitor Signal	Output Unit	Remarks
Pn006 or Pn007	n.□□00 (default setting of Pn007)	Motor Speed	<ul style="list-style-type: none"> ■ Rotary Servomotor: 1 V/1,000 min⁻¹ ■ Linear Servomotor: 1 V/1,000 mm/s 	–
	n.□□01	Speed Reference	<ul style="list-style-type: none"> ■ Rotary Servomotor: 1 V/1,000 min⁻¹ ■ Linear Servomotor: 1 V/1,000 mm/s 	–

Parameter		Description		
		Monitor Signal	Output Unit	Remarks
n.□□02 (default setting of Pn006)	Torque Reference	1 V/100% rated torque	–	
n.□□03	Position Deviation	0.05 V/Reference unit	0 V for speed or torque control	
n.□□04	Position Amplifier Deviation	0.05 V/encoder pulse unit	Position deviation after electronic gear conversion	
n.□□05	Position Reference Speed	<ul style="list-style-type: none"> ■ Rotary Servomotor: 1 V/1,000 min⁻¹ ■ Linear Servomotor: 1 V/1,000 mm/s 	–	
n.□□06	Reserved Setting (Do not change.)	–	–	
n.□□07	Load - Motor Position Deviation	0.01 V/Reference unit	–	
n.□□08	Positioning Completion	Positioning completed: 5 V Positioning not completed: 0 V	Completion is indicated by the output voltage.	
n.□□09	Speed Feedforward	<ul style="list-style-type: none"> ■ Rotary Servomotor: 1 V/1,000 min⁻¹ ■ Linear Servomotor: 1 V/1,000 mm/s 	–	
n.□□0A	Torque Feedforward	1 V/100% rated torque	–	
n.□□0B	Active Gain*	1st gain: 1 V 2nd gain: 2 V	The gain that is active is indicated by the output voltage.	
n.□□0C	Completion of Position Reference Distribution	Distribution completed: 5 V Distribution not completed: 0 V	Completion is indicated by the output voltage.	
n.□□0D	External Encoder Speed	1 V/1,000 min ⁻¹	Value calculated at the motor shaft	
n.□□10	Main Circuit DC Voltage	1 V/100 V (main circuit DC voltage)	–	

* Refer to the following section for details.

→ [Chap. 9.13.2 'Gain Switching' ...page 370](#)

Changing the Monitor Factor and Offset

You can change the monitor factors and offsets for the output voltages for analog monitor 1 and analog monitor 2. The relationships to the output voltages are as follows:

$$\begin{aligned} \text{Analog monitor 1 output voltage} &= (-1) \times \left\{ \text{Analog Monitor 1 Signal Selection (Pn006 = n.}\square\square\text{XX)} \times \text{Analog Monitor 1 Magnification (Pn552)} + \text{Analog Monitor 1 Offset Voltage (Pn550)} \right\} \\ \text{Analog monitor 2 output voltage} &= (-1) \times \left\{ \text{Analog Monitor 2 Signal Selection (Pn007 = n.}\square\square\text{XX)} \times \text{Analog Monitor 2 Magnification (Pn553)} + \text{Analog Monitor 2 Offset Voltage (Pn551)} \right\} \end{aligned}$$

Fig. 329: Changing the Monitor Factor and Offset

The following parameters are set.

Analog Monitor 1 Offset Voltage

	Setting Range	Setting Unit	Default Setting	When Enabled	Classification
Pn550	-10,000 to 10,000	0.1 V	0	Immediately	Setup

(applies to Speed Control, Position Control and Torque Control)

Analog Monitor 2 Offset Voltage

	Setting Range	Setting Unit	Default Setting	When Enabled	Classification
Pn551	-10,000 to 10,000	0.1 V	0	Immediately	Setup

(applies to Speed Control, Position Control and Torque Control)

Analog Monitor 1 Magnification

	Setting Range	Setting Unit	Default Setting	When Enabled	Classification
Pn552	-10,000 to 10,000	×0.01	100	Immediately	Setup

(applies to Speed Control, Position Control and Torque Control)

Analog Monitor 2 Magnification

	Setting Range	Setting Unit	Default Setting	When Enabled	Classification
Pn553	-10,000 to 10,000	×0.01	100	Immediately	Setup

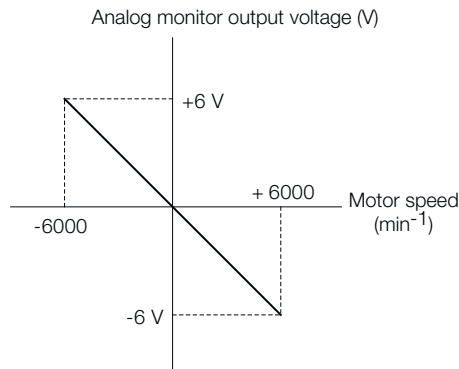
(applies to Speed Control, Position Control and Torque Control)

Example

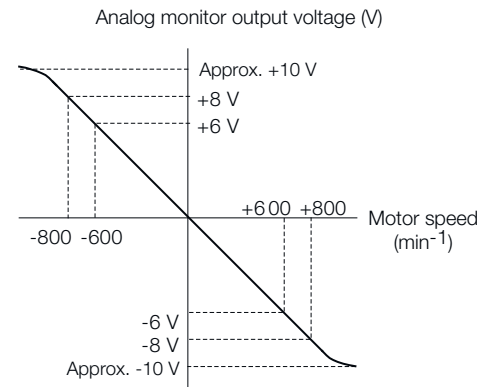
Example for Setting the Item to Monitor to the Motor Speed (Pn006 = n.□□00)

Monitoring Machine Operation Status and Signal Waveforms > Using the Analog Monitors

When Pn552 = 100 (Setting Unit: $\times 0.01$)



When Pn552 = 1,000 (Setting Unit: $\times 0.01$)



Note: The effective linearity range is ± 8 V.
The resolution is 16 bits.

Fig. 330: Setting the Item to Monitor to the Motor Speed

Adjusting the Analog Monitor Output

You can manually adjust the offset and gain for the analog monitor outputs for the torque reference monitor and motor speed monitor.

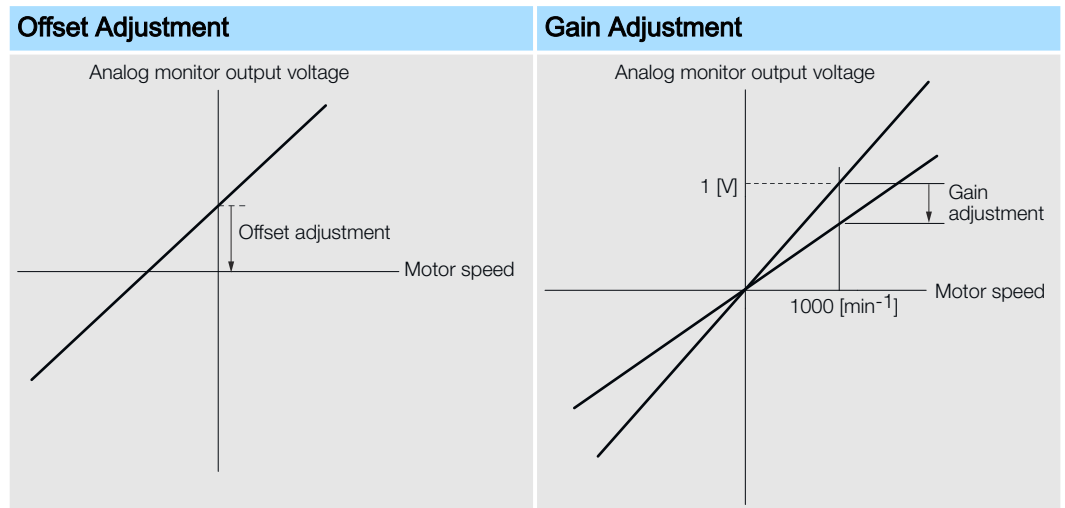
The offset is adjusted to compensate for offset in the zero point caused by output voltage drift or noise in the monitoring system.

The gain is adjusted to match the sensitivity of the measuring system.

The offset and gain are adjusted at the factory. You normally do not need to adjust them.

An example of adjusting the output of the motor speed monitor is provided below.

Adjustment Example



Offset Adjustment

Item	Specification
Offset Adjustment Range	-2.4 V to 2.4 V
Adjustment Unit	18.9 mV/LSB

Gain Adjustment

Item	Specification
Offset Adjustment Range	100 \pm 50%
Adjustment Unit	0.4%/LSB

The gain adjustment range is made using a 100% output value (gain adjustment of 0) as the reference value with an adjustment range of 50% to 150%.

A setting example is given below.

- Setting the Adjustment Value to -125
 $100 + (-125 \times 0.4) = 50$ [%]
 Therefore, the monitor output voltage goes to 50% of the original value.
- Setting the Adjustment Value to 125
 $100 + (125 \times 0.4) = 150$ [%]
 Therefore, the monitor output voltage goes to 150% of the original value.



- The adjustment values do not use parameters, so they will not change even if the parameter settings are initialized.
- Adjust the offset with the measuring instrument connected so that the analog monitor output value goes to zero. The following setting example achieves a zero output.
 - While power is not supplied to the Servomotor, set the monitor signal to the torque reference.
 - In speed control, set the monitor signal to the position deviation.

Preparations

- Confirm the following condition before you adjust the analog monitor output:
 The parameters must not be write prohibited.

Applicable Tools

You can use the following tools to adjust analog monitor outputs. The function that is used is given for each tool.

Offset Adjustment

Tool	Function	Operating Procedure Reference
Digital Operator	Fn00C	Σ-7-Series Digital Operator Operating Manual (Manual No.: SIEP S800001 33)
SigmaWin+	Setup - Analog Monitor Output Adjustment	Operating Procedure for SigmaWin+, see below

Gain Adjustment

Tool	Function	Operating Procedure Reference
Digital Operator	Fn00D	Σ-7-Series Digital Operator Operating Manual (Manual No.: SIEP S800001 33)
SigmaWin+	Setup - Analog Monitor Output Adjustment	Operating Procedure for SigmaWin+, see below

Operating Procedure for SigmaWin+

Use the following procedure to adjust the analog monitor output.

1. Click the Servo Drive Button in the workspace of the Main Window of the SigmaWin+.
2. Select **Adjust the Analog Monitor Output** in the Menu Dialog Box.
 - ➔ The Adjust the Analog Monitor Output Dialog Box will be displayed.

3. → Click the **Zero Adjustment** or **Gain Adjustment** Tab.

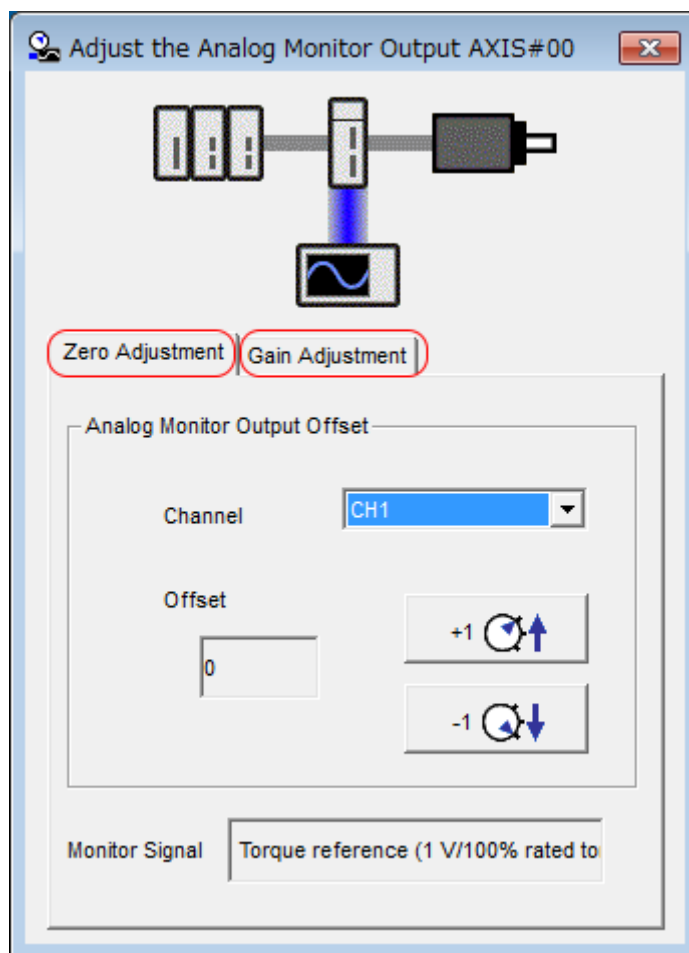


Fig. 331: Adjust the Analog Monitor Output AXIS#00

4. → While watching the analog monitor, use the +1 and -1 Buttons to adjust the offset. There are two channels: CH1 and CH2. If necessary, click the down arrow on the **Channel** Box and select the channel.

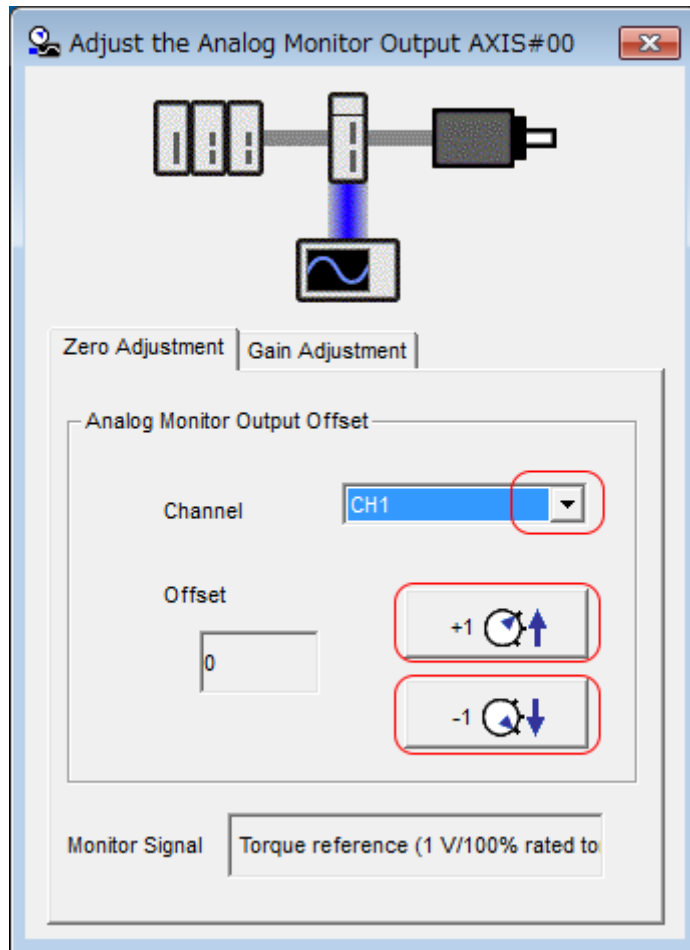


Fig. 332: Adjust the Analog Monitor Output AXIS#00 - Analog Monitor Output Offset
 This concludes adjusting the analog monitor output.

10.5 Monitoring Product Life


10.5.1 Items That You Can Monitor

Monitor Item	Description
SERVOPACK Installation Environment	The operating status of the SERVOPACK in terms of the installation environment is displayed. Implement one or more of the following actions if the monitor value exceeds 100%. <ul style="list-style-type: none"> ■ Lower the surrounding temperature. ■ Decrease the load.
Servomotor Installation Environment	The operating status of the SERVOPACK in terms of the installation environment is displayed. Implement one or more of the following actions if the monitor value exceeds 100%. <ul style="list-style-type: none"> ■ Lower the surrounding temperature. ■ Decrease the load.

Monitor Item	Description
Built-in Fan Service Life Prediction	<p>The unused status of the SERVOPACK is treated as the 100% value. The value decreases each time the main circuit power supply is turned ON and each time the servo is turned OFF. Use a monitor value of 0% as a guideline for the replacement period. Refer to the following section for part replacement guidelines.</p> <p>➔ Chap. 16.2.3 'Guidelines for Part Replacement' ...page 546</p>
Capacitor Service Life Prediction	<p>The unused status of the SERVOPACK is treated as the 100% value. The value decreases each time the main circuit power supply is turned ON and each time the servo is turned OFF. Use a monitor value of 0% as a guideline for the replacement period. Refer to the following section for part replacement guidelines.</p> <p>➔ Chap. 16.2.3 'Guidelines for Part Replacement' ...page 546</p>
Surge Prevention Circuit Service Life Prediction	<p>The unused status of the SERVOPACK is treated as the 100% value. The value decreases each time the main circuit power supply is turned ON and each time the servo is turned OFF. Use a monitor value of 0% as a guideline for the replacement period. Refer to the following section for part replacement guidelines.</p> <p>➔ Chap. 16.2.3 'Guidelines for Part Replacement' ...page 546</p>
Dynamic Brake Circuit Service Life Prediction	<p>The unused status of the SERVOPACK is treated as the 100% value. The value decreases each time the main circuit power supply is turned ON and each time the servo is turned OFF. Use a monitor value of 0% as a guideline for the replacement period. Refer to the following section for part replacement guidelines.</p> <p>➔ Chap. 16.2.3 'Guidelines for Part Replacement' ...page 546</p>

10.5.2 Operating Procedure

Use the following procedure to display the installation environment and service life prediction monitor dialog boxes.

1. ➔ Click the  Servo Drive Button in the workspace of the Main Window of the SigmaWin+.
2. ➔ Select **Life Monitor** in the Menu Dialog Box.
 - ➔ The Life Monitor Dialog Box will be displayed.



With the Digital Operator, you can use Un025 to Un02A to monitor this information.

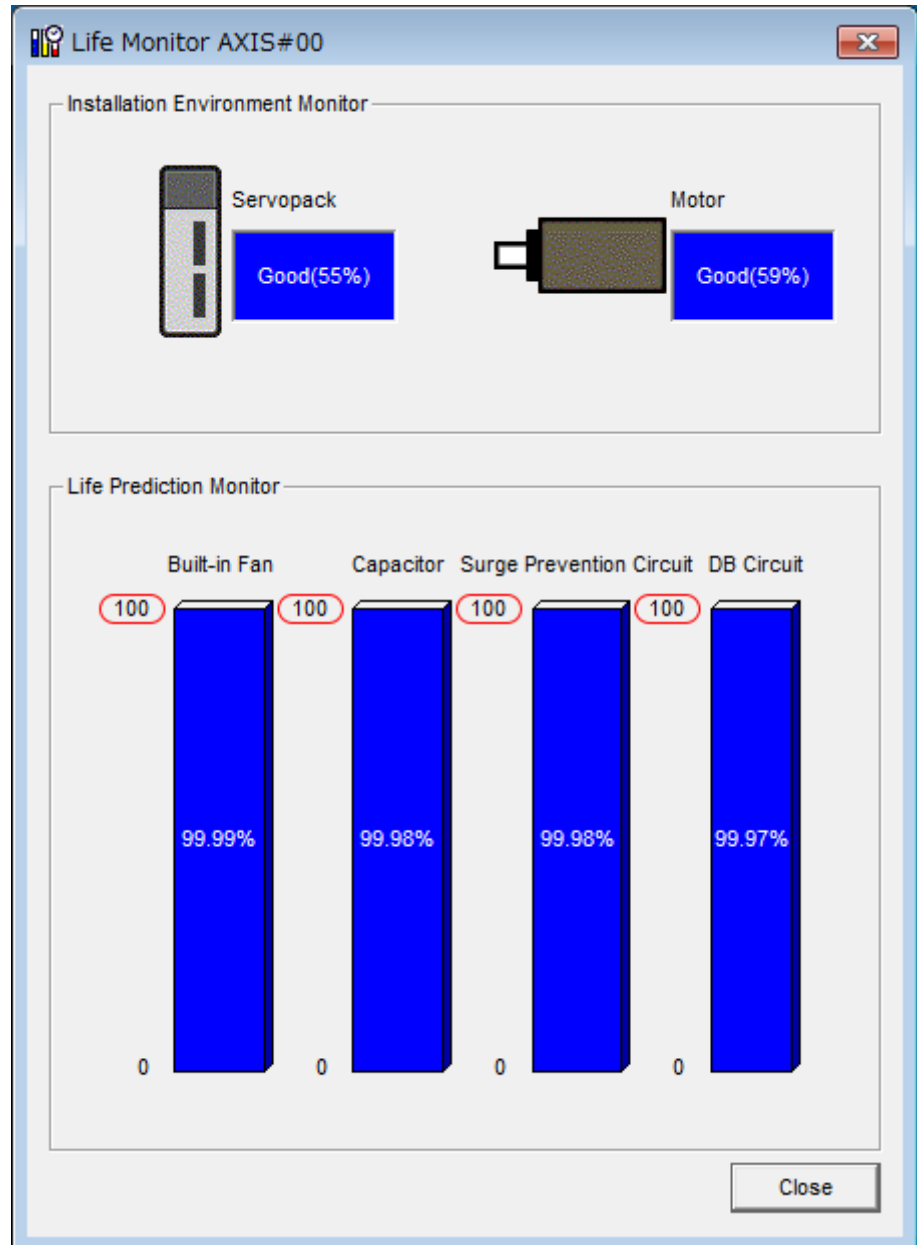


Fig. 333: Life Monitor AXIS#00

A value of 100% indicates that the SERVOPACK has not yet been used. The percentage decreases as the SERVOPACK is used and reaches 0% when it is time to replace the SERVOPACK.

10.5.3 Preventative Maintenance

You can use the following functions for preventative maintenance.

- Preventative maintenance warnings
- /PM (Preventative Maintenance Output) signal

The SERVOPACK can notify the host controller when it is time to replace any of the main parts.

Preventative Maintenance Warning

An A.9b0 warning (Preventative Maintenance Warning) is detected when any of the following service life prediction values drops to 10% or less: SERVOPACK built-in fan life, capacitor life, inrush current limiting circuit life, and dynamic brake circuit life. You can change the setting of Pn00F = n.□□□X to enable or disable these warnings.

Parameter		Description	When Enabled	Classification
Pn00F	n.□□□0 (default setting)	Do not detect preventative maintenance warnings.	After restart	Setup
	n.□□□1	Detect preventative maintenance warnings.		

/PM (Preventative Maintenance Output) Signal

The /PM (Preventative Maintenance Output) signal is output when any of the following service life prediction values reaches 10% or less: SERVOPACK built-in fan life, capacitor life, inrush current limiting circuit life, and dynamic brake circuit life. The /PM (Preventative Maintenance Output) signal must be allocated.

Even if detection of preventive maintenance warnings is disabled (Pn00F = n.□□□0), the /PM signal will still be output as long as it is allocated.

Classification	Signal	Connector Pin No.	Signal Status	Description
Output	/PM	Must be allocated.	ON (closed)	One of the following service life prediction values reached 10% or less: SERVOPACK built-in fan life, capacitor life, inrush current limiting circuit life, and dynamic brake circuit life.
			OFF (open)	All of the following service life prediction values are greater than 10%: SERVOPACK built-in fan life, capacitor life, inrush current limiting circuit life, and dynamic brake circuit life.



You must allocate the /PM signal to use it. Use Pn514 = n.□□□X (/PM (Preventative Maintenance Output) Signal Allocation) to allocate the signal to connector pins. Refer to the following section for details.

→ [Chap. 7.2.3 'Output Signal Allocations' ...page 190](#)

10.6 Alarm Tracing

10.6.1 Overview

Alarm tracing records data in the SERVOPACK from before and after an alarm occurs. This data helps you to isolate the cause of the alarm.

You can display the data recorded in the SERVOPACK as a trace waveform on the SigmaWin+.



- Alarms that occur when the power supply is turned ON are not recorded.
- Alarms that occur during the recording of alarm trace data are not recorded.
- Alarms that occur while utility functions are being executed are not recorded.


10.6.2 Data for Which Alarm Tracing Is Performed

Two types of data are recorded for alarm tracing: numeric data and I/O signal ON/OFF data.

Numeric Data	ON/OFF Data
Torque reference	ALM
Feedback speed	Servo ON command (/S-ON)
Reference speed	Proportional control command (/P-CON)
Position reference speed	Forward torque command (/P-CL)
Position deviation	Reverse torque command (/N-CL)
Motor-load position deviation	G-SEL1 signal (/G-SEL1)
Main circuit bus voltage	ACON

10.6.3 Applicable Tools

The following table lists the tools that you can use to perform alarm tracing and the applicable tool functions.

Tool	Function	Operating Procedure Reference
Panel Operator	You cannot display alarm tracing data from the Panel Operator.	
Digital Operator	You cannot display alarm tracing data from the Digital Operator.	
SigmaWin+	<i>Alarm – Alarm Tracing</i>	 Engineering Tool SigmaWin+ Operation Manual (Manual No.: SIET S80001 34)

11 Fully-Closed Loop Control

11.1 Overview

This chapter provides detailed information on performing fully-closed loop control with the SERVOPACK.

11.2 Fully-Closed System

With a fully-closed system, an externally installed encoder is used to detect the position of the controlled machine and the machine's position information is fed back to the SERVOPACK. High-precision positioning is possible because the actual machine position is fed back directly. With a fully-closed system, looseness or twisting of mechanical parts may cause vibration or oscillation, resulting in unstable positioning.

Refer to the following manual for details on Fully-closed Modules.

📖 Σ -7-Series Peripheral Device Selection Manual (Manual No.: SIEP S800001 32)

The following figure shows an example of the system configuration.

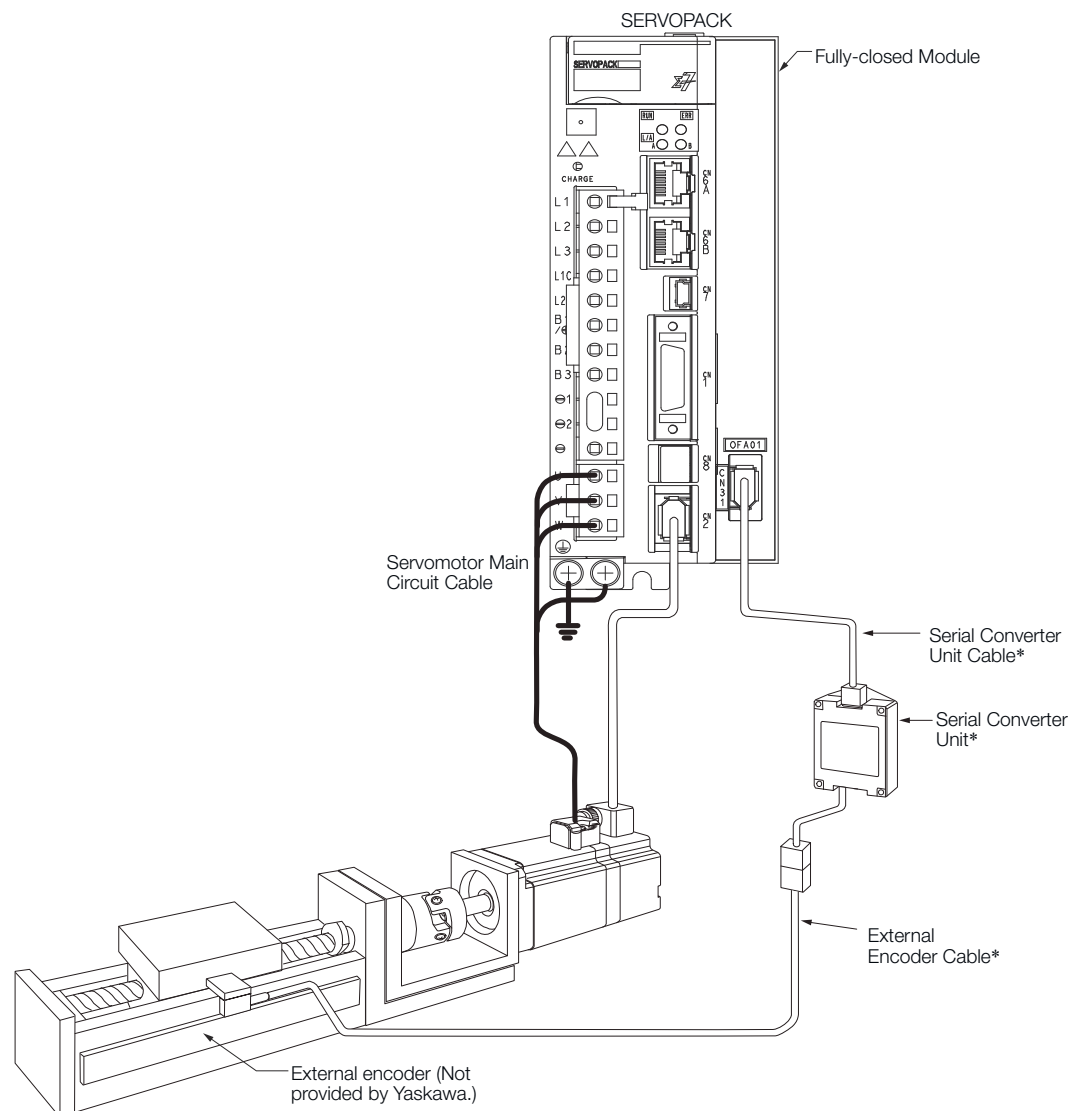


Fig. 334: Fully-Closed System - Rotary Servomotor

* The connected devices and cables depend on the type of external linear encoder that is used.



Refer to the following section for details on connections that are not shown above, such as connections to power supplies and peripheral devices.

→ Chap. 3.5 'Examples of Standard Connections between SERVOPACKs and Peripheral Devices' ...page 72

11.3 SERVOPACK Commissioning Procedure

First, confirm that the SERVOPACK operates correctly with semi-closed loop control, and then confirm that it operates correctly with fully-closed loop control.

The commissioning procedure for the SERVOPACK for fully-closed loop control is given below.

Step	Description	Operation	Required Parameter and Object Settings	Controlling Device
1	<p>Check operation of the entire sequence with semi-closed loop control and without a load.</p> <p>Items to Check</p> <ul style="list-style-type: none"> ■ Power supply circuit wiring ■ Servomotor wiring ■ Encoder wiring ■ Wiring of I/O signal lines from the host controller ■ Servomotor rotation direction, motor speed, and multi-turn data ■ Operation of safety mechanisms, such as the brakes and the overtravel mechanisms 	<p>Set the parameters so that the SERVOPACK operates correctly in semi-closed loop control without a load and check the following points. Set Pn002 to n.0□□□ to specify semi-closed loop control.</p> <ul style="list-style-type: none"> ■ Are there any errors in the SERVOPACK? ■ Does jogging function correctly when you operate the SERVOPACK without a load? ■ Do the I/O signals turn ON and OFF correctly? ■ Is power supplied to the Servomotor when the Servo ON command (Enable Operation command) is sent from the host controller? ■ Does the Servomotor operate correctly when a position reference is input by the host controller? 	<ul style="list-style-type: none"> ■ Pn000 (Basic Function Selections 0) ■ Pn001 (Application Function Selection 1) ■ Pn002 = n.X□□□ (External Encoder Usage) ■ Position reference unit (<i>Position User Unit</i> (2301h)) ■ Pn50A, Pn50B, Pn511, and Pn516 (Input Signal Selections) ■ Pn50E, Pn50F, Pn510, and Pn514 (Output Signal Selections) 	SERVO-PACK or host controller
2	<p>Check operation with the Servomotor connected to the machine with semi-closed loop control.</p> <p>Items to Check</p> <ul style="list-style-type: none"> ■ Initial response of the system connected to the machine ■ Movement direction, travel distance, and movement speed as specified by the references from the host controller 	<p>Connect the Servomotor to the machine. Set the moment of inertia ratio in Pn103 using autotuning without a host reference.</p> <p>Check that the machine's movement direction, travel distance, and movement speed agree with the references from the host controller.</p>	Pn103 (Moment of Inertia Ratio)	Host controller

Step	Description	Operation	Required Parameter and Object Settings	Controlling Device
3	<p>Check the external encoder.</p> <p>Items to Check</p> <ul style="list-style-type: none"> Is the signal from the external encoder received correctly? 	<p>Set the parameters related to fullyclosed loop control and move the machine with your hand without turning ON the power supply to the Servomotor. Check the following status with the Digital Operator or SigmaWin+.</p> <ul style="list-style-type: none"> Does the fully-closed feedback pulse counter count up when the Servomotor moves in the forward direction? Is the travel distance of the machine visually about the same as the amount counted by the fully-closed feedback pulse counter? <p>Note: The unit for the fully-closed feedback pulse counter is pulses, which is equivalent to the external encoder sine wave pitch.</p>	<ul style="list-style-type: none"> Pn002 = n.X□□□ (External Encoder Usage) Pn20A (Number of External Scale Pitches) Position reference unit (<i>Position User Unit</i> (2301h)) Pn281 (Encoder Output Resolution) Pn51B (Motor-Load Position Deviation Overflow Detection Level) Pn522 (Positioning Completed Width) Pn52A (Multiplier per Fully-closed Rotation) 	–
4	<p>Perform a program jogging operation.</p> <p>Items to Check</p> <p>Does the fully-closed system operate correctly for the SERVOPACK without a load?</p>	<p>Perform a program jogging operation and confirm that the travel distance is the same as the reference value in Pn531.</p> <p>When you perform program jogging, start from a low speed and gradually increase the speed.</p>	Pn530 to Pn536 (program jogging-related parameters)	SERVO-PACK
5	<p>Operate the SERVOPACK.</p> <p>Items to Check</p> <p>Does the fully-closed system operate correctly, including the host controller?</p>	<p>Input a position reference and confirm that the SERVOPACK operates correctly.</p> <p>Start from a low speed and gradually increase the speed.</p>	–	Host controller

11.4 Parameter and Object Settings for Fully-closed Loop Control

11.4.1 Overview

This section describes the parameter settings that are related to fully-closed loop control.

Parameter and Object to Set	Setting	Position Control	Speed Control	Torque Control	Reference
Pn000 = n.□□□X	Motor direction	✓	✓	✓	↪ Chap. 11.4.3 'Setting the Motor Direction and the Machine Movement Direction' ...page 433
Pn002 = n.X□□□	External encoder usage method	✓	✓	✓	
Pn20A	Number of external scale pitches	✓	✓	✓	↪ Chap. 11.4.4 'Setting the Number of External Encoder Scale Pitches' ...page 434

Parameter and Object to Set	Setting	Position Control	Speed Control	Torque Control	Reference
Pn281	Encoder divided pulse output signals (PAO, PBO, and PCO) from the SERVOPACK	✓	✓	✓	➔ Chap. 11.4.5 'Setting the PAO, PBO, and PCO (Encoder Divided Pulse Output) Signals' ...page 434
–	External absolute encoder data reception sequence	✓	✓	✓	➔ Chap. 7.10.5 'Reading the Position Data from the Absolute Linear Encoder' ...page 231
Position User Unit (2301h)	Electronic gear ratio	✓	–	–	➔ Chap. 6.15.2 'Setting the Position Reference Unit' ...page 172
Pn51B	Excessive deviation level between Servomotor and load positions	✓	–	–	➔ Chap. 11.4.8 'Alarm Detection Settings' ...page 436
Pn52A	Multiplier for one fully-closed rotation	✓	–	–	
Pn006/ Pn007	Analog monitor signal	✓	✓	✓	➔ Chap. 11.4.9 'Analog Monitor Signal Settings' ...page 437
Pn22A = n.X□□□	Speed feedback method during fullyclosed loop control	✓	–	–	➔ Chap. 11.4.10 'Setting to Use an External Encoder for Speed Feedback' ...page 437

11.4.2 Control Block Diagram for Fully-Closed Loop Control

The control block diagram for fully-closed loop control is provided below.

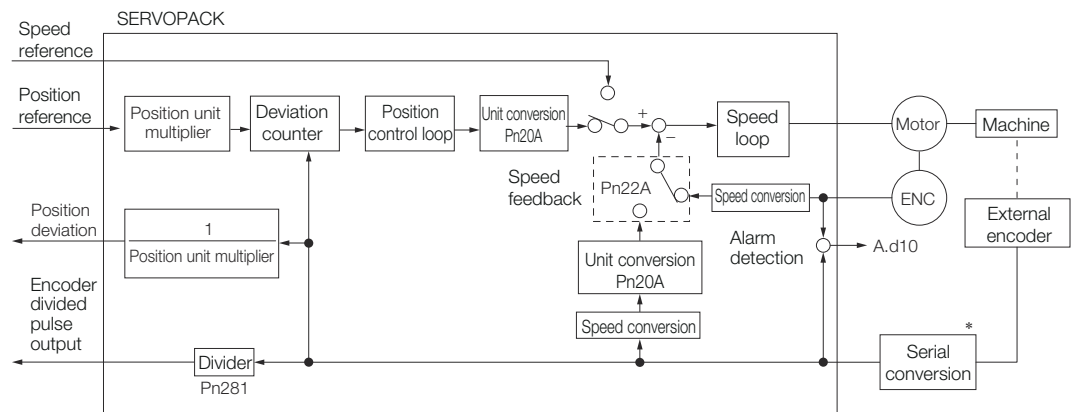


Fig. 335: Control Block Diagram for Fully-Closed Loop Control

* The connected device depends on the type of external encoder.



You can use either an incremental or an absolute encoder. If you use an absolute encoder, set Pn002 to n.□1□□ (Use the absolute encoder as an incremental encoder).

11.4.3 Setting the Motor Direction and the Machine Movement Direction

You must set the motor direction and the machine movement direction. To perform fully-closed loop control, you must set both Pn000 = n.□□□X (Rotation Direction Selection) and Pn002 = n.X□□□ (External Encoder Usage).

Parameter			Pn002 = n.X□□□ (External Encoder Usage)			
			n.1□□□		n.3□□□	
Pn000 = n.□□□X (Rotation Direction Selection)	n.□□□0	Reference direction	Forward reference	Reverse reference	Forward reference	Reverse reference
		Motor direction	CCW	CW	CCW	CW
		External encoder	Forward movement	Reverse movement	Reverse movement	Forward movement
	n.□□□1	Reference direction	Forward reference	Reverse reference	Forward reference	Reverse reference
		Motor direction	CW	CCW	CW	CCW
		External encoder	Reverse movement	Forward movement	Forward movement	Reverse movement

- Phase B leads in the divided pulses for a forward reference regardless of the setting of Pn000 = n.□□□X.
- Forward direction: The direction in which the pulses are counted up.
- Reverse direction: The direction in which the pulses are counted down.

Related Parameters

- Pn000 = n.□□□X

Refer to the following section for details.

➔ [Chap. 6.5 'Motor Direction Setting' ...page 141](#)

- Pn002 = n.X□□□

When you perform fully-closed loop control, set Pn002 to n.1□□□ or n.3□□□.

Parameter		Name	Description	When Enabled	Classification
Pn002	n.0□□□ (default setting)	External Encoder Usage	Do not use an external encoder.	After restart	Setup
	n.1□□□		External encoder moves in forward direction for CCW motor rotation.		
	n.2□□□		Reserved parameter (Do not change.)		
	n.3□□□		External encoder moves in reverse direction for CCW motor rotation.		
	n.4□□□		Reserved parameter (Do not change.)		



Determine the setting of Pn002 = n.X□□□ as described below.

- Set Pn000 to n.□□□□ (Use the direction in which the linear encoder counts up as the forward direction) and set Pn002 to n.1□□□ (The external encoder moves in the forward direction for CCW motor rotation).
- Manually rotate the motor shaft counterclockwise.
- If the fully-closed feedback pulse counter counts up, do not change the setting of Pn002 (Pn002 = n.1□□□).
- If the fully-closed feedback pulse counter counts down, set Pn002 to n.3□□□.

11.4.4 Setting the Number of External Encoder Scale Pitches

Set the number of external encoder scale pitches per Servomotor rotation in Pn20A.

Setting Example

Specifications

- External encoder scale pitch: 20 μm
- Ball screw lead: 30 mm

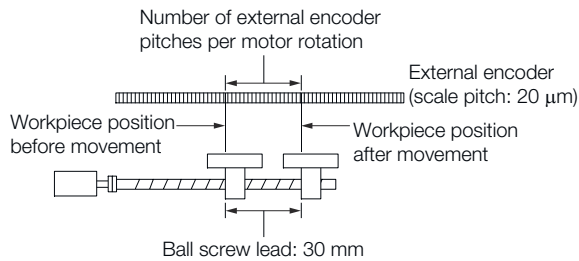


Fig. 336: Setting Example - Number of External Encoder Scale Pitches

If the external encoder is connected directly to the Servomotor, the setting will be 1,500 (30 mm/0.02 mm = 1,500).



- If there is a fraction, round off the digits below the decimal point.
- If the number of external encoder scale pitches per Servomotor rotation is not an integer, there will be deviation in the position loop gain (Kp), feedforward, and position reference speed monitor. This is not relevant for the position loop and it therefore does not interfere with the position accuracy.

Related Parameters

Number of External Scale Pitches

	Setting Range	Setting Unit	Default Setting	When Enabled	Classification
Pn20A	4 to 1,048,576	1 scale pitch/revolution	32,768	After restart	Setup

(applies to Position Control)

11.4.5 Setting the PAO, PBO, and PCO (Encoder Divided Pulse Output) Signals

Set the position resolution in Pn281 (Encoder Output Resolution).

Enter the number of phase A and phase B edges for the setting.

Setting Example**Specifications**

- External encoder scale pitch: 20 μm
- Ball screw lead: 30 mm
- Speed: 1,600 mm/s

If a single pulse (multiplied by 4) is output for 1 μm, the setting would be 20.

If a single pulse (multiplied by 4) is output for 0.5 μm, the setting would be 40.

The encoder divided pulse output would have the following waveform if the setting is 20.

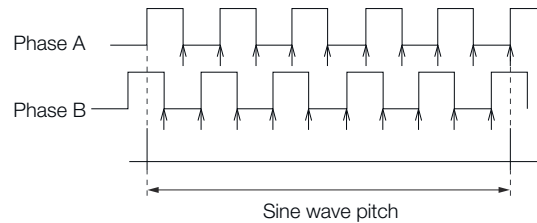


Fig. 337: Encoder Divided Pulse Output

“↑” indicates the edge positions. In this example, the set value is 20 and therefore the number of edges is 20.



The upper limit of the encoder signal output frequency (multiplied by 4) is 6.4 Mpps (Million Pulses per Second). Do not set a value that would cause the output to exceed 6.4 Mpps.

If the output exceeds the upper limit, an A.511 alarm (Overspeed of Encoder Output Pulse Rate) will be output.

Example

If the setting is 20 and the speed is 1,600 mm/s, the output frequency would be 1.6 Mpps

$$\frac{1600 \text{ mm/s}}{0.001 \text{ mm}} = 1,600,000 = 1.6 \text{ Mpps}$$

Fig. 338: Setting Example Formula - Encoder Divided Pulse Output

Because 1.6 Mpps is less than 6.4 Mpps, this setting can be used.

Related Parameters**Encoder Output Resolution**

	Setting Range	Setting Unit	Default Setting	When Enabled	Classification
Pn281	1 to 4,096	1 edge/pitch	20	After restart	Setup

(applies to Position Control)



The maximum setting for the encoder output resolution is 4,096. If the resolution of the external encoder exceeds 4,096, pulse output will no longer be possible at the resolution given in [↔ 'Calculating the Settings for the Electronic Gear Ratio' ...page 173.](#)

11.4.6 External Absolute Encoder Data Reception Sequence

Refer to the following section for details.

[↔ Chap. 7.10.5 'Reading the Position Data from the Absolute Linear Encoder' ...page 231](#)

With fully-closed loop control, the same sequence as for a Linear Servomotor is used.

11.4.7 Setting Unit Systems

Refer to the following section for details.

→ [Chap. 6.15.1 'Setting Unit Systems' ...page 171](#)

With fully-closed loop control, the same setting as for a Linear Servomotor is used.

11.4.8 Alarm Detection Settings

This section describes the alarm detection settings (Pn51B and Pn52A).

Pn51B (Motor-Load Position Deviation Overflow Detection Level)

This setting is used to detect the difference between the feedback position of the Servomotor encoder and the feedback load position of the external encoder for fully-closed loop control. If the detected difference exceeds the setting, an A.d10 alarm (Motor-Load Position Error Overflow) will be output.

Motor-Load Position Deviation Overflow Detection Level

	Setting Range	Setting Unit	Default Setting	When Enabled	Classification
Pn51B	0 to 1,073,741,823	1 reference unit	1000	Immediately	Setup

(applies to Position Control)



If you set this parameter to 0, A.d10 alarms will not be output and the machine may be damaged.

Pn52A (Multiplier per One Fully-closed Rotation)

Set the coefficient of the deviation between the motor and the external encoder per motor rotation.

This setting can be used to prevent the motor from running out of control due to damage to the external encoder or to detect belt slippage.

- Setting Example
- Increase the value if the belt slips or is twisted excessively.
- If this parameter is set to 0, the external encoder value will be read as it is.
- If you use the default setting of 20, the second rotation will start with the deviation for the first motor rotation multiplied by 0.8.

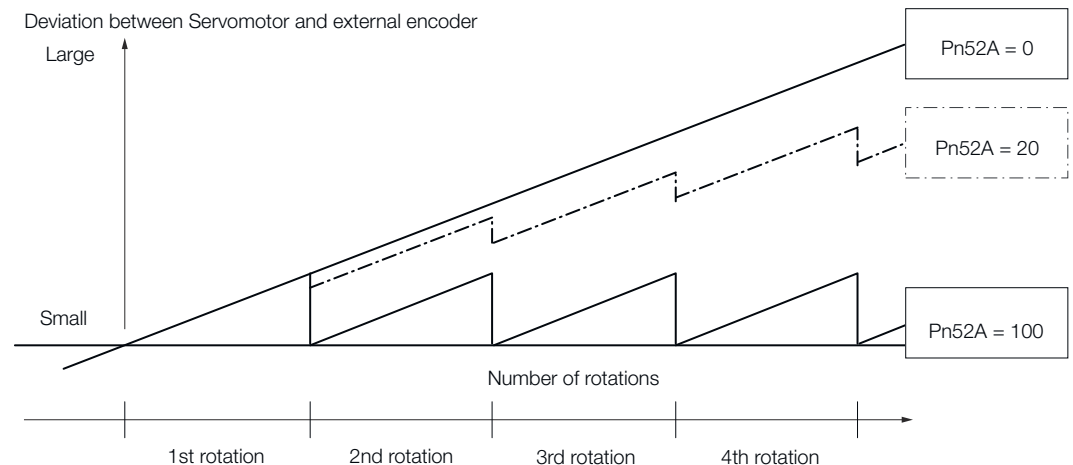


Fig. 339: Pn52A (Multiplier per One Fully-closed Rotation)

- Related Parameters

Multiplier per One Fully-closed Rotation

	Setting Range	Setting Unit	Default Setting	When Enabled	Classification
Pn52A	0 to 100	1%	20	Immediately	Setup

(applies to Position Control)

11.4.9 Analog Monitor Signal Settings

You can monitor the position deviation between the Servomotor and load with an analog monitor.

Parameter	Name	Description	When Enabled	Classification
Pn006	n.□□07	Analog Monitor 1 Signal Selection	Immediately	Setup
Pn007	n.□□07	Analog Monitor 2 Signal Selection		

11.4.10 Setting to Use an External Encoder for Speed Feedback

For fully-closed loop control, you normally set a parameter to specify using the motor encoder speed (Pn22A = n.0□□□).

If you will use a Direct Drive Servomotor and a high-resolution external encoder, set the parameter to specify using the speed of the external encoder (Pn22A = n.1□□□).

Parameter	Meaning	When Enabled	Classification
Pn22A	n.0□□□ (default setting)	After restart	Setup
	n.1□□□		



This parameter cannot be used if Pn002 is set to n.0□□□ (Do not use external encoder).

11.5 Monitoring an External Encoder

11.5.1 Overview

You can monitor the current value of an external encoder attached to a machine without creating a fully-closed loop.

A dual encoder system with an encoder in the Rotary Servomotor and an external encoder attached to the machine is used, but only the encoder in the Rotary Servomotor is used in the control loop.

The external encoder is used only to monitor the current position of the machine. You can also use a touch probe to latch the current position of an external encoder.

11.5.2 Option Module Required for Monitoring

A Fully-closed Module (SGDV-OFA01A) is required to use this function.

Refer to the following manual for detailed information on installation.

 Σ -V-Series/ Σ -V-Series for Large-Capacity Models/ Σ -7-Series Installation Guide Fully-closed Module (Manual No.: TOBP C720829 03)



You cannot use a Safety Module (SGDV-OSA01A000FT900) if you install a Fully-closed Module.

11.5.3 Related Parameters

The parameter that is used to monitor the external encoder as the current value of the machine is given below.

Parameter		Meaning	When Enabled	Classification
Pn00E	n.0□□□ (default setting)	Do not use the external encoder monitor.	After startup	Setup
	n.1□□□	Use CCW as the forward direction.		
	n.2□□□	Reserved setting (Do not use.)		
	n.3□□□	Use CW as the forward direction. (Reverse Rotation Mode)		
	n.4□□□	Reserved setting (Do not use.)		

Set Pn002 to n.0□□□ (Do not use external encoder) if you will not use fully-closed loop control.

11.5.4 Block Diagrams

A simple block diagram is given below to provide an overall image of monitoring an external encoder.

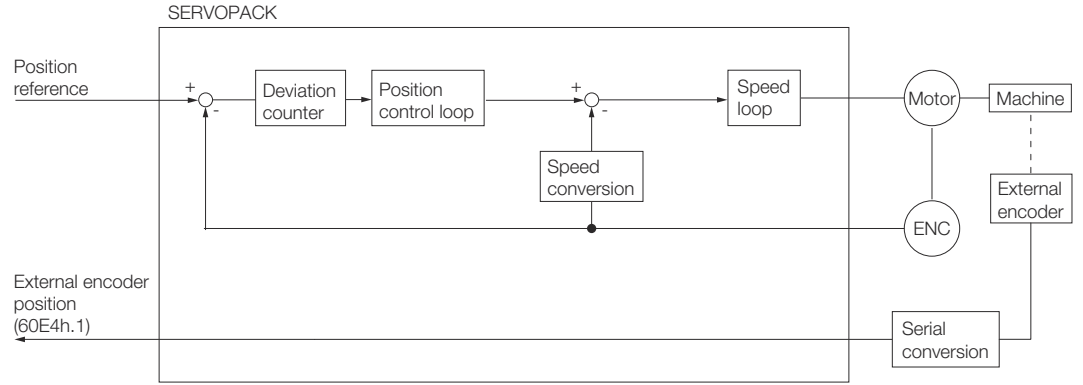


Fig. 340: Monitoring an External Encoder

The following block diagram shows monitoring an external encoder in the Profile Position Mode.

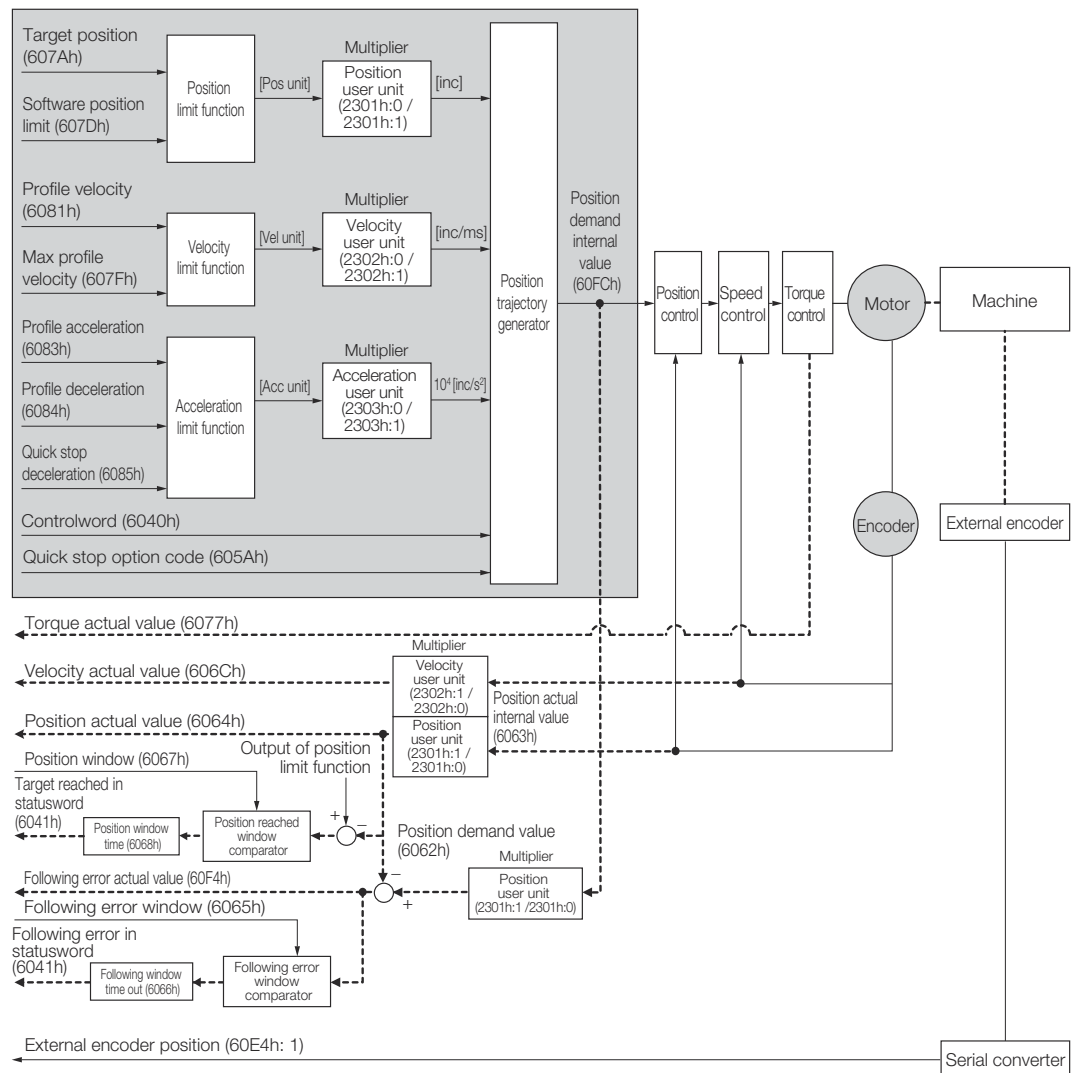


Fig. 341: Monitoring an External Encoder in the Profile Position Mode

12 Safety Functions

12.1 Overview

This chapter provides detailed information on the safety functions of the SERVOPACK.

12.2 Introduction to the Safety Functions

12.2.1 Safety Functions

Safety functions are built into the SERVOPACK to reduce the risks associated with using the machine by protecting workers from the hazards of moving machine parts and otherwise increasing the safety of machine operation.

Especially when working in hazardous areas inside guards, such as for machine maintenance, the safety function can be used to avoid hazardous moving machine parts.

The SERVOPACK provides the following four safety functions for functional safety standards.

Function	Description	SERVO-PACK Built-in Function	Safety Module Function	
				Active Mode Function*1
Hard Wire Base Block (HWBB and SBB)	This safety function is equivalent to the Safety Torque OFF function defined in IEC 61800-5-2.	Yes (HWBB)	Yes (SBB*2)	–
Safety Base Block with Delay (SBB-D)*2	This safety function is equivalent to the Safety Stop 1 function defined in IEC 61800-5-2.	–	Yes	Yes
Safe Position Monitor with Delay (SPM-D)*2	This safety function is equivalent to the Safety Stop 2 function defined in IEC 61800-5-2.	–	Yes	Yes
Safe Speed Limit with Delay (SLS-D)*2	This safety function is equivalent to the Safely-Limited Speed function defined in IEC 61800-5-2.	–	Yes	–

*1. The Active Mode Function stops the motor according to the speed reference that is preset in a parameter in the SERVOPACK when the safety request input signal turns OFF during SBB-D or SPM-D. The Active Mode Function is not a safety function in the applicable standards. Keep this in mind when you design the system.

Refer to the following section for details.

➔ [Chap. 12.8.5 'Active Mode Function' ...page 454](#)

*2. A Safety Module (optional) must be connected to use this function. Refer to the following manual for application procedures.

📖 [Σ-V-Series/Σ-V-Series for Large-Capacity Models/Σ-7-Series Installation Guide Safety Module \(Manual No.: SIEP C720829 06\)](#)

Refer to the following section for information on the safety function and safety parameters.

➔ [Chap. 1.7 'Compliance with UL Standards, EU Directives, and Other Safety Standards' ...page 40](#)



Products that display the TÜV mark on the nameplate have met the safety standards.

12.2.2 Precautions for Safety Functions



WARNING

- To confirm that the HWBB function satisfies the safety requirements of the system, you must conduct a risk assessment of the system.
Incorrect use of the safety function may cause injury.
- The Servomotor will move if there is an external force (e.g., gravity on a vertical axis) even when the HWBB function is operating. Use a separate means, such as a mechanical brake, that satisfies the safety requirements.
Incorrect use of the safety function may cause injury.
- While the HWBB function is operating, the Servomotor may move within an electric angle of 180° or less as a result of a SERVOPACK failure. Use the HWBB function for an application only after confirming that movement of the Servomotor will not result in a hazardous condition.
Incorrect use of the safety function may cause injury.
- The dynamic brake and the brake signal are not safety-related elements. You must design the system so that SERVOPACK failures will not cause a hazardous condition while the HWBB function is operating.
Incorrect use of the safety function may cause injury.
- Connect devices that satisfy the safety standards for the signals for safety functions.
Incorrect use of the safety function may cause injury.
- The HWBB function does not shut OFF the power to the SERVOPACK or electrically isolate it. Implement measures to shut OFF the power supply to the SERVOPACK before you perform maintenance on it.
There is a risk of electric shock.

12.3 Hard Wire Base Block (HWBB and SBB)

12.3.1 Overview

A hard wire base block (abbreviated as HWBB) is a safety function that is designed to shut OFF the current to the motor with a hardwired circuit.

The drive signals to the Power Module that controls the motor current are controlled by the circuits that are independently connected to the two input signal channels to turn OFF the Power Module and shut OFF the motor current.



For safety function signal connections, the input signal is the 0-V common and the output signal is a source output.

This is opposite to other signals described in this manual.

To avoid confusion, the ON and OFF status of signals for the safety function are defined as follows:

ON: The state in which the relay contacts are closed or the transistor is ON and current flows into the signal line.

OFF: The state in which the relay contacts are open or the transistor is OFF and no current flows into the signal line.

The input signal uses the 0-V common. The following figure shows a connection example.

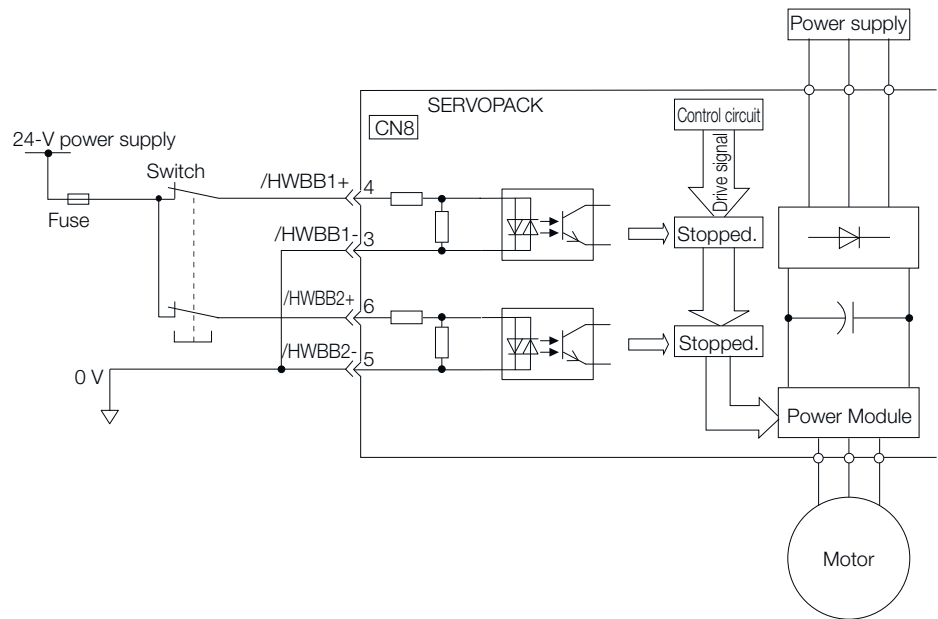


Fig. 342: Connection Example - Hard Wire Base Block

12.3.2 Risk Assessment

When using the HWBB, you must perform a risk assessment of the servo system in advance to confirm that the safety level of the standards is satisfied. Refer to the following section for details on the standards.

→ Chap. 1.7 'Compliance with UL Standards, EU Directives, and Other Safety Standards' ...page 40



To meet performance level e (PLe) in EN ISO 13849-1 and SIL3 in IEC 61508, the EDM1 signal must be monitored by the host controller. If the EDM1 signal is not monitored by the host controller, the level will be safety performance level c (PLc) and SIL1.

The following hazards exist even when the HWBB is operating. These hazards must be included in the risk assessment.

- The Servomotor will move if an external force is applied to it (for example, gravity on a vertical axis). Implement measures to hold the Servomotor, such as installing a separate mechanical brake.
- If a failure occurs such as a Power Module failure, the Servomotor may move within an electric angle of 180°. Ensure safety even if the Servomotor moves.

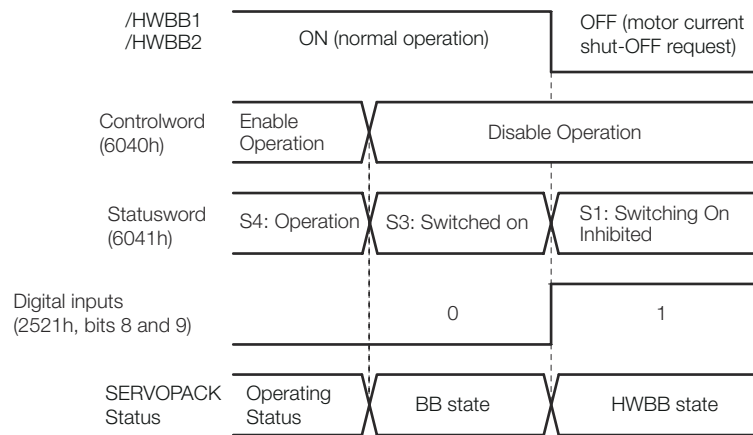
The rotational angle or travel distance depends on the type of Servomotor as follows:

- Rotary Servomotor: 1/6 rotation max. (rotational angle calculated at the motor shaft)
- Direct Drive Servomotor: 1/20 rotation max. (rotational angle calculated at the motor shaft)
- Linear Servomotor: 50 mm max.
- The HWBB does not shut OFF the power to the SERVOPACK or electrically isolate it. Implement measures to shut OFF the power supply to the SERVOPACK before you perform maintenance on it.

12.3.3 Hard Wire Base Block (HWBB) State

The SERVOPACK will be in the following state if the HWBB operates. If the /HWBB1 or /HWBB2 signal turns OFF, the HWBB will operate and the SERVOPACK will enter a HWBB state.

- When HWBB Operates after Servo OFF (Power Not Supplied to Motor)



- When HWBB Operates While Power Is Supplied to Servomotor

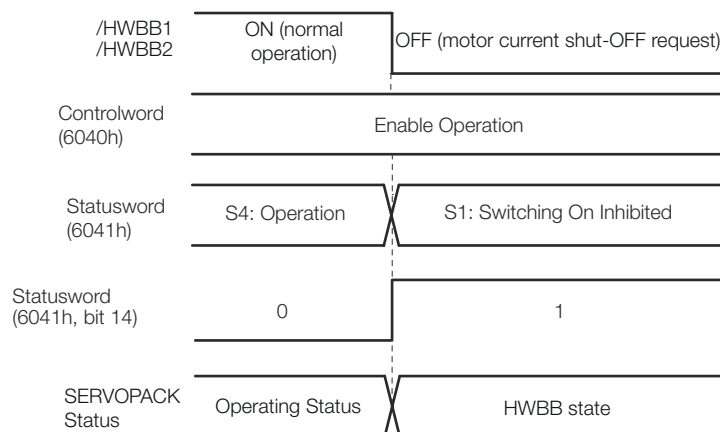


Fig. 343: Hard Wire Base Block (HWBB) State

12.3.4 Resetting the HWBB State

Normally, after the Shutdown command is received and power is no longer supplied to the Servomotor, the /HWBB1 and /HWBB2 signals will turn OFF and the SERVOPACK will enter the HWBB state. If you turn ON the /HWBB1 and /HWBB2 signals in this state, the SERVOPACK will enter a base block (BB) state and will be ready to acknowledge the Servo ON command (Enable Operation command).

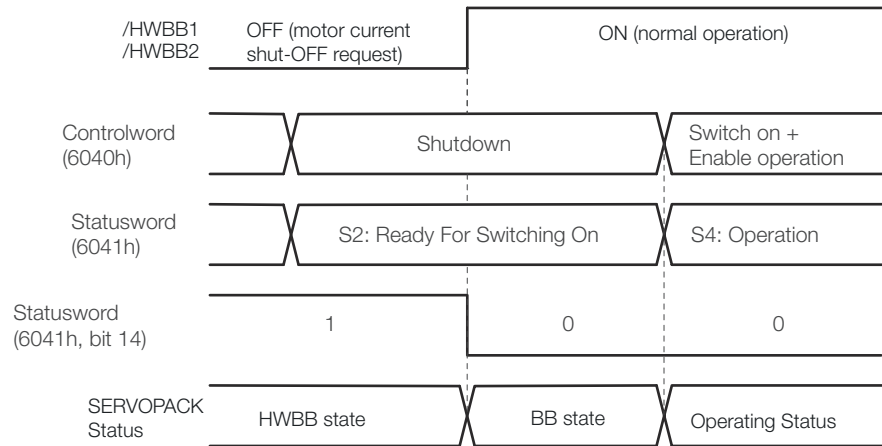


Fig. 344: Resetting the HWBB State - 1

If the /HWBB1 and /HWBB2 signals are OFF and the Servo ON command (Enable Operation command) is received, the HWBB state will be maintained even after the /HWBB1 and /HWBB2 signals are turned ON.

Send the Shutdown command to place the SERVOPACK in the BB state and then send the Servo ON command (Enable Operation command).

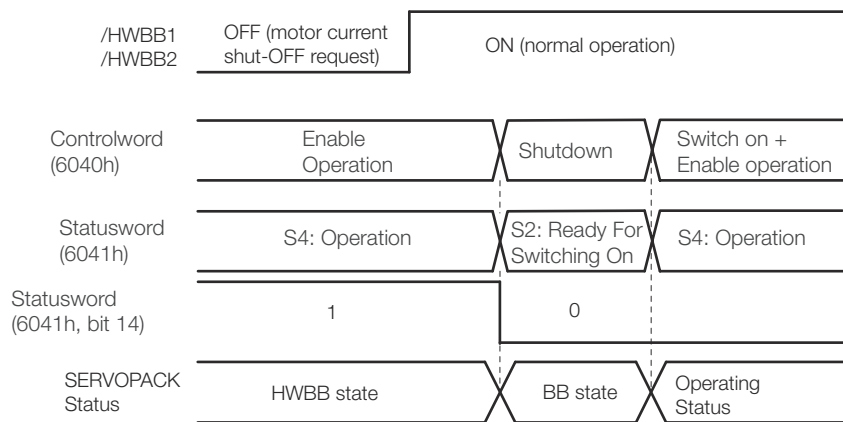


Fig. 345: Resetting the HWBB State - 2



If the SERVOPACK is placed in the BB state while the main circuit power supply is OFF, the HWBB state will be maintained until the Shutdown command is received.

12.3.5 Recovery Method

Recovery Conditions

All of the following conditions must be met.

- All safety request inputs are ON.
- The Servo ON command (Enable Operation command) was not sent.
- None of the following utility functions have been executed. (These functions execute the Servo ON command (Enable Operation command).)

The following utility functions execute the Servo ON command (Enable Operation command).

Utility Function No.	Function Name
Fn002	Jog
Fn003	Origin Search
Fn004	Jog Program
Fn00E	Autotune Motor Current Detection Signal Offset
Fn080	Polarity Detection
Fn201	Advanced Autotuning without Reference
Fn206	Easy FFT



If any of the above utility functions was executed, the utility function must be ended. Perform the operation to return to the Main Menu for the utility functions on the Digital Operator. Refer to the following manual for operating procedures.

Σ-7-Series Digital Operator Operating Manual (Manual No.: SIEP S80001 33)

Recovery Procedure

1. Specify Shutdown in *controlword* (6040h, bits 0 to 3) to reset the Servo Drive.
2. Specify Switch ON and the Servo ON command (Enable Operation command) in *controlword* (6040h, bits 0 to 3).

Power will be supplied to the motor.

12.3.6 Detecting Errors in HWBB Signal

If only the /HWBB1 or the /HWBB2 signal is input, an A.Eb1 alarm (Safety Function Signal Input Timing Error) will occur unless the other signal is input within 10 seconds. This makes it possible to detect failures, such as disconnection of an HWBB signal.



CAUTION

The A.Eb1 alarm (Safety Function Signal Input Timing Error) is not a safety-related element. Keep this in mind when you design the system.

12.3.7 HWBB Input Signal Specifications

If an HWBB is requested by turning OFF the two HWBB input signal channels (/HWBB1 and /HWBB2), the power supply to the Servomotor will be turned OFF within 8 ms.

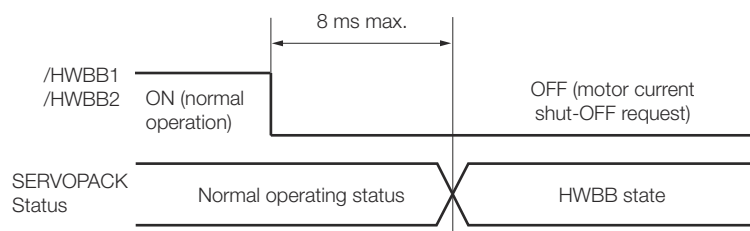


Fig. 346: HWBB Input Signal Specifications

i

- The OFF status is not recognized if the OFF interval of the /HWBB1 or /HWBB2 signal is 0.5 ms or shorter.
- You can check the status of the input signals by using monitor displays. Refer to the following section for details.
[→ Chap. 10.3.3 'I/O Signal Monitor' ...page 414](#)

12.3.8 Operation without a Host Controller

The HWBB will operate even for operation without a host controller.

However, if the HWBB operates during execution of the following functions, leave the execution mode for the function and then enter it again to restart operation. Operation will not be restarted simply by turning OFF the /HWBB1 and /HWBB2 signals.

Applicable Functions	Resetting the HWBB State
<ul style="list-style-type: none"> ■ Jogging ■ Origin search ■ Program jogging ■ Automatic adjustment without host reference ■ Easy FFT ■ Adjustment of motor current detection signal offset 	<p>The diagram shows the following sequence: 1. Function execution mode is ON. 2. /HWBB1 and /HWBB2 are ON (normal operation). 3. Function execution mode turns OFF (motor current shut-OFF request). 4. /HWBB1 and /HWBB2 turn OFF. 5. Function execution mode turns ON (Not function execution mode). 6. /HWBB1 and /HWBB2 turn ON (normal operation). 7. Function execution mode turns ON (Function execution mode). 8. SERVOPACK Status transitions from Operating Status to HWBB state, then to BB state, and finally back to Operating Status.</p>

12.3.9 /S-RDY (Servo Ready Output) Signal

The Servo ON command (Enable Operation command) will not be acknowledged in the HWBB state. Therefore, the Servo Ready Output Signal will turn OFF. The Servo Ready Output Signal will turn ON if both the /HWBB1 and /HWBB2 signals are ON and the servo is turned OFF (BB state).

An example is provided below for when the main circuit power supply is ON when there is no servo alarm.

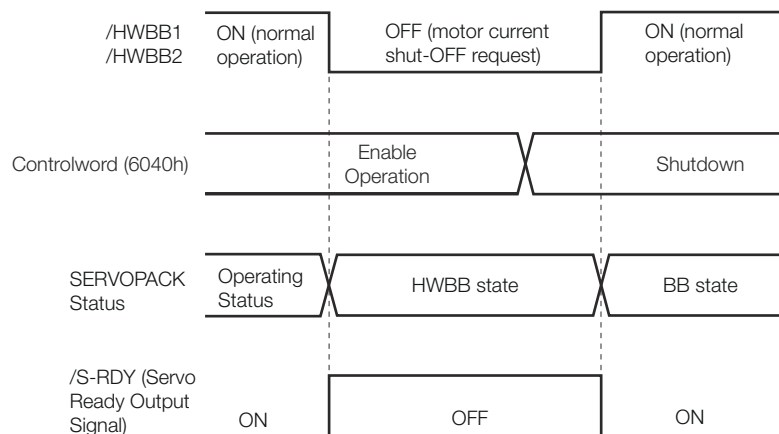


Fig. 347: Servo Ready Output Signal

12.3.10 /BK (Brake Output) Signal

If the HWBB operates when the /HWBB1 or /HWBB2 signal is OFF, the /BK (Brake) signal will turn OFF. At that time, the setting in Pn506 (Brake Reference - Servo OFF Delay Time) will be disabled. Therefore, the Servomotor may be moved by external force until the actual brake becomes effective after the /BK signal turns OFF.

**CAUTION**

The brake signal is not a safety-related element. You must design the system so that a hazardous condition does not occur even if the brake signal fails in the HWBB state. Also, if a Servomotor with a Brake is used, keep in mind that the brake in the Servomotor is used only to prevent the moving part from being moved by gravity or an external force and it cannot be used to stop the Servomotor.

12.3.11 Stopping Methods

If the /HWBB1 or /HWBB2 signal turns OFF and the HWBB operates, the Servomotor will stop according to the stop mode that is set for stopping the Servomotor when the servo turns OFF (Pn001 = n.□□□X). However, if the dynamic brake is enabled (Pn001 = n.□□□0 or n.□□□1), observe the following precautions.

**CAUTION**

- The dynamic brake is not a safety-related element. You must design the system so that a hazardous condition does not occur even if the Servomotor coasts to a stop in the HWBB state. Normally, we recommend that you use a sequence that returns to the HWBB state after stopping for a reference.
- If the application frequently uses the HWBB, stopping with the dynamic brake may result in the deterioration of elements in the SERVOPACK. To prevent internal elements from deteriorating, use a sequence in which the HWBB state is returned to after the Servomotor has come to a stop.

12.3.12 ALM (Servo Alarm) Signal

The ALM (Servo Alarm) signal is not output in the HWBB state.

12.4 EDM1 (External Device Monitor)

12.4.1 Overview

The EDM1 (External Device Monitor) signal is used to monitor failures in the HWBB. Connect the monitor signal as a feedback signal, e.g., to the Safety Unit.



To meet performance level e (PLe) in EN ISO 13849-1 and SIL3 in IEC 61508, the EDM1 signal must be monitored by the host controller. If the EDM1 signal is not monitored by the host controller, the level will be safety performance level c (Plc) and SIL1.

**Safety Module Monitor (2410h)**

You can also use Safety Module Monitor (2410h) to monitor the Safety Module.

Failure Detection Signal for EDM1 Signal

The relationship between the EDM1, /HWBB1, and /HWBB2 signals is shown below.

Detection of failures in the EDM1 signal circuit can be achieved by using the status of the /HWBB1, /HWBB2, and EDM1 signals in the following table. A failure can be detected by checking the failure status, e.g., when the power supply is turned ON.

Signal	Logic			
/HWBB1	ON	ON	OFF	OFF
/HWBB2	ON	OFF	ON	OFF
EDM1	OFF	OFF	OFF	ON



WARNING

The EDM1 signal is not a safety output. Use it only for monitoring for failures.

12.4.2 EDM1 Output Signal Specifications

If an HWBB is requested by turning OFF the two HWBB input signal channels (/HWBB1 and /HWBB2) when the safety function is operating normally, the EDM1 output signal will be turned ON within 8 ms.

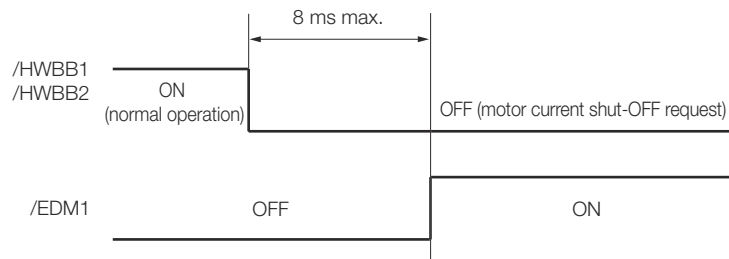


Fig. 348: EDM1 Output Signal Specifications

12.5 Applications Examples for Safety Functions

12.5.1 Overview

This section provides examples of using the safety functions.

12.5.2 Connection Example

In the following example, a Safety Unit is used and the HWBB operates when the guard is opened.

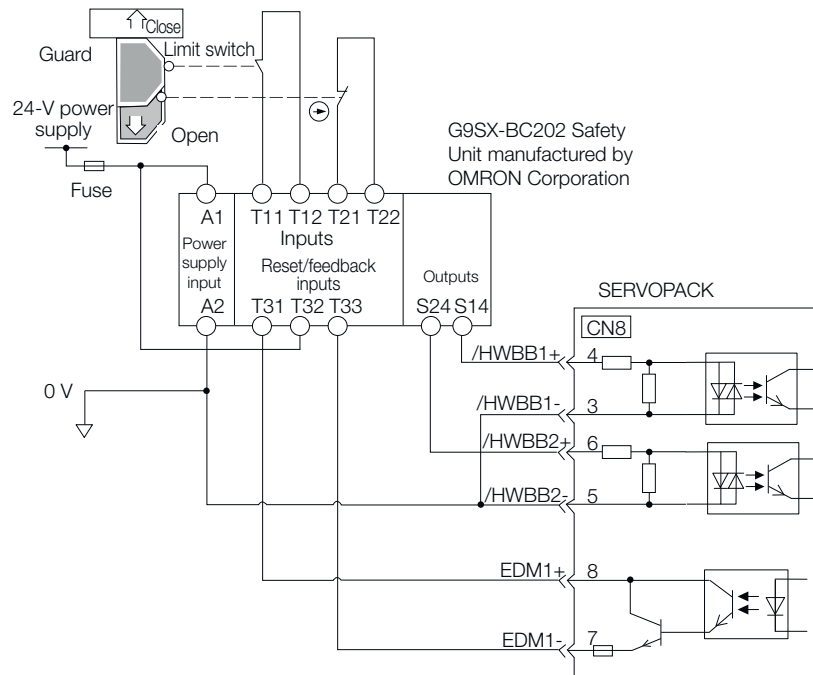


Fig. 349: Safety Functions - Connection Example

When the guard is opened, both the /HWBB1 and the /HWBB2 signals turn OFF, and the EDM1 signal turns ON. Because the feedback circuit is ON while the guard is closed, the Safety Unit is reset, the /HWBB1 and the /HWBB2 signals turn ON, and the operation is enabled.



The EDM1 signal is used as a source output. Connect the EDM1 so that the current flows from EDM1+ to EDM1-.

12.5.3 Failure Detection Method

If a failure occurs (e.g., the /HWBB1 or the /HWBB2 signal remains ON), the Safety Unit is not reset when the guard is closed because the EDM1 signal remains OFF. Therefore starting is not possible and a failure is detected.

In this case the following must be considered: an error in the external device, disconnection of the external wiring, short-circuiting in the external wiring, or a failure in the SERVOPACK. Find the cause and correct the problem.

12.5.4 Procedure

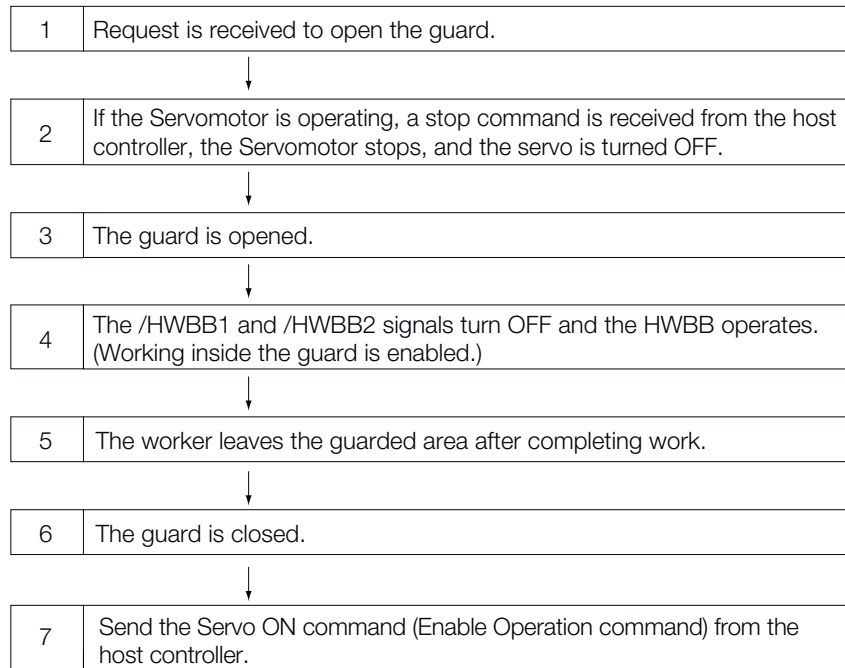


Fig. 350: Procedure - Safety Functions - Connection Example

12.6 Validating Safety Functions

When you commission the system or perform maintenance or SERVOPACK replacement, you must always perform the following validation test on the HWBB after completing the wiring. (It is recommended that you keep the confirmation results as a record.)



- When the /HWBB1 and /HWBB2 signals turn OFF, confirm that the Digital Operator displays **Hbb** and that the Servomotor does not operate.
- Monitor the ON/OFF status of the /HWBB1 and /HWBB2 signals. If the ON/OFF status of the signals do not coincide with the display, the following must be considered: an error in the external device, disconnection of the external wiring, short-circuiting in the external wiring, or a failure in the SERVOPACK. Find the cause and correct the problem.
Refer to the following sections for details on the monitor.
[↪ Chap. 10.3.3 'I/O Signal Monitor' ...page 414](#)
- Confirm that the EDM1 signal is OFF while in normal operation by using the feedback circuit input display of the connected device.

12.7 Connecting a Safety Function Device

Use the following procedure to connect a safety function device.

1. → Remove the Safety Jumper Connector from the connector for the safety function device (CN8).

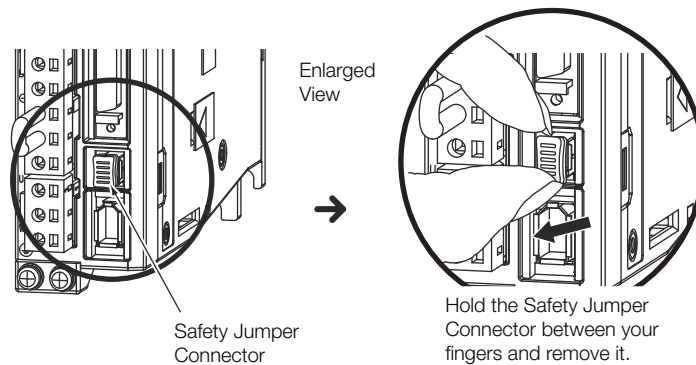


Fig. 351: Removing the Safety Jumper Connector CN8

2. → Connect the safety function device to the connector for the safety function device (CN8).



*If you do not connect a safety function device, leave the Safety Jumper Connector connected to the connector for the safety function device (CN8). If the SERVOPACK is used without the Safety Jumper Connector connected to CN8, no current will be supplied to the Servomotor and no motor torque will be output. In this case, **Hbb** will be displayed on the Digital Operator.*

12.8 Safety Module Safety Functions

12.8.1 Overview

This section describes the safety functions provided by the Safety Module.

12.8.2 Safety Base Block with Delay (SBB-D)

The Safety Base Block with Delay (SBB-D) function operates according to the Safe Stop 1 (SS1) function defined in IEC 61800-5-2. The deceleration operation of the motor is monitored (deceleration monitoring) until the time set in a parameter elapses in response to the safety request input status. The HWBB in the SERVOPACK is then executed to shut OFF the power supply to the motor.



Refer to the following manual for the application procedures for the SBB-D function.

Σ -V-Series/ Σ -V-Series for Large-Capacity Models/ Σ -7-Series User's Manual Safety Module (Manual No.: SIEP C720829 06)

Operation Example for SBB-D

When the safety monitor time expires, the safe state (HWBB) is entered and then the power supply to the motor is shut OFF. The Drive enters the Switch ON Disabled state (*statusword* (6041h)).

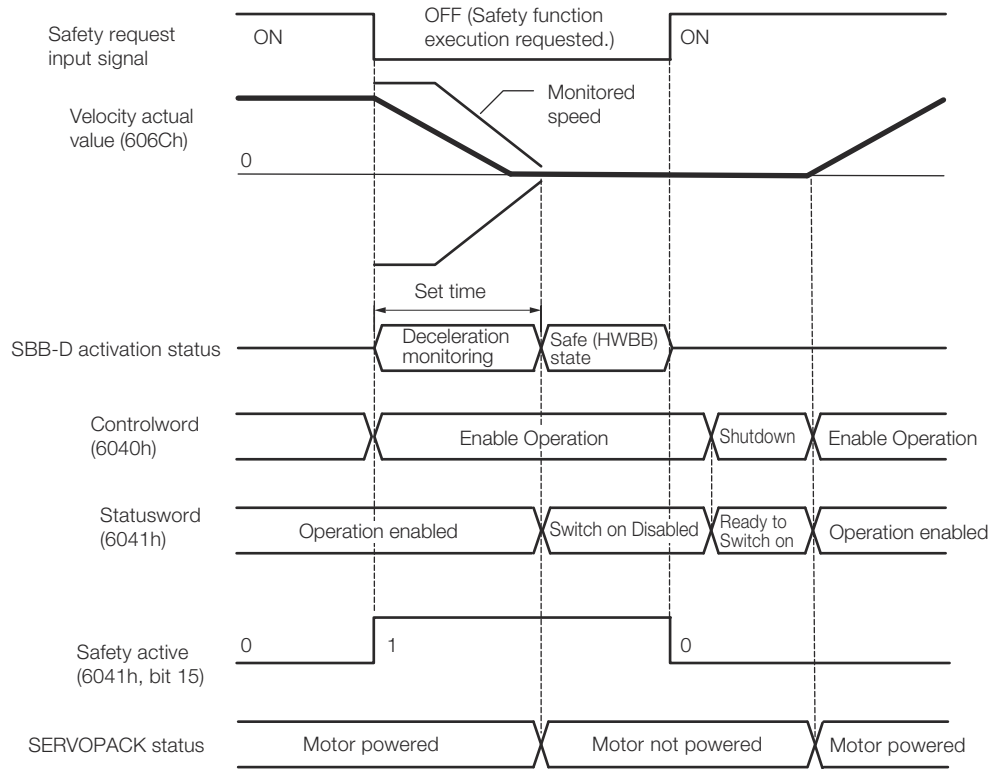


Fig. 352: Operation Example for SBB-D

Recovery Method

When the safety request input signal turns ON, normal operation will be enabled.

The recovery method after deceleration monitoring is completed and the safe (HWBB) state is entered is the same as for the HWBB function. Refer to the following section for details.

➔ [Chap. 12.3.5 'Recovery Method' ...page 444](#)

12.8.3 Safe Position Monitor with Delay (SPM-D)

The Safe Position Monitor with Delay (SPM-D) function operates according to the Safe Stop 2 (SS2) function defined in IEC 61800-5-2. The deceleration operation of the motor is monitored (deceleration monitoring) until the time set in a parameter elapses in response to the safety request input status. Position monitoring is then performed to see if the motor travel distance is within the allowable range.



Refer to the following manual for the application procedures for the SPM-D function.

Σ-V-Series/Σ-V-Series for Large-Capacity Models/Σ-7-Series User's Manual Safety Module (Manual No.: SIEP C720829 06)

Operation Example for SPM-D

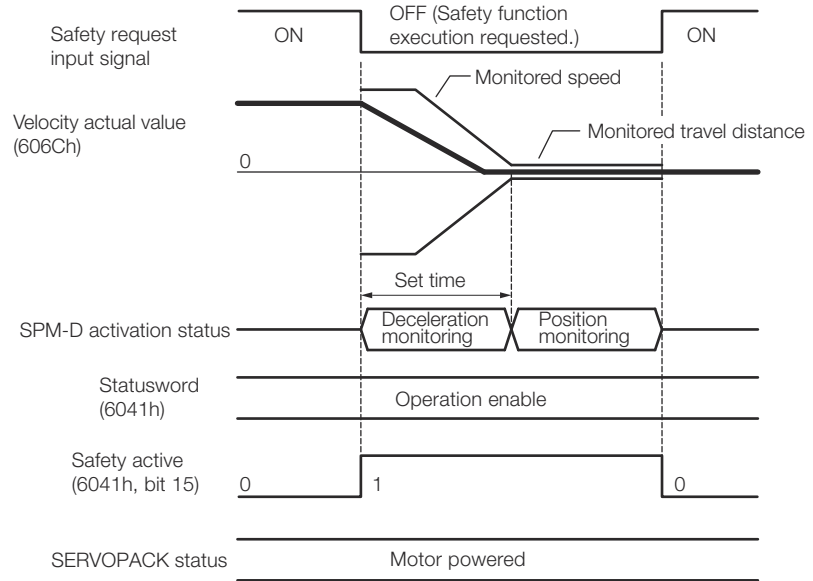


Fig. 353: Operation Example for SPM-D

Recovery Method

When the safety request input signal turns ON, normal operation will be enabled.

The recovery method after deceleration monitoring is completed and the safe (HWBB) state is entered in the same as for the HWBB function. Refer to the following section for details.

→ [Chap. 12.3.5 'Recovery Method' ...page 444](#)

12.8.4 Safe Speed Limit with Delay (SLS-D)

The Safe Speed Limit with Delay (SLS-D) function operates according to the Safely-Limited Speed (SLS) function defined in IEC 61800-5-2. The deceleration operation of the motor is monitored (deceleration monitoring) until the time set in a parameter elapses in response to the safety request input status. The motor speed is then monitored to see if it is within the allowable range (within range for a constant speed).



Refer to the following manual for the application procedures for the SLS-D function.

Σ-V-Series/Σ-V-Series for Large-Capacity Models/Σ-7-Series User's Manual Safety Module (Manual No.: SIEP C720829 06)

Operation Example for SLS-D

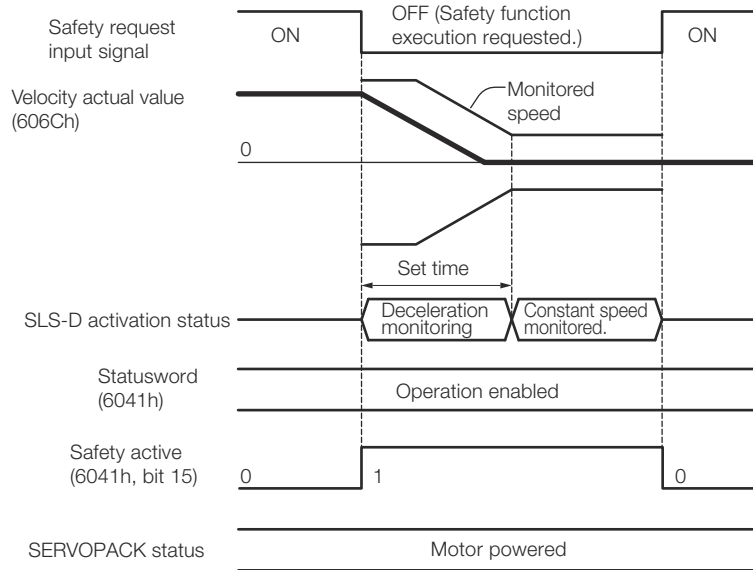


Fig. 354: Operation Example for SLS-D

Recovery Method

When the safety request input signal turns ON, normal operation will be enabled.

The recovery method after deceleration monitoring is completed and the safe (HWBB) state is entered is the same as for the HWBB function. Refer to the following section for details.

sd → [Chap. 12.3.5 'Recovery Method' ...page 444](#)

12.8.5 Active Mode Function

The Active Mode Function stops the motor according to the deceleration reference that is preset in a parameter in the SERVOPACK when the safety request input signal turns OFF during SBB-D or SPM-D.

Active Mode Function Operation Example

If Profile Torque Mode or Cyclic Synchronous Torque Mode is set in *controlword* (6040h, bits 4 to 9), the servo will be turned OFF and the motor will be stopped as soon as the safety request input signal turns OFF.

When Using the SBB-D Function (Position or Speed Control)

The motor is stopped at the set deceleration rate (Pn622 or Pn623). After the deceleration monitor time (Pc11 or Pc21) elapses, the servo is turned OFF (Switch ON Disable state is entered).

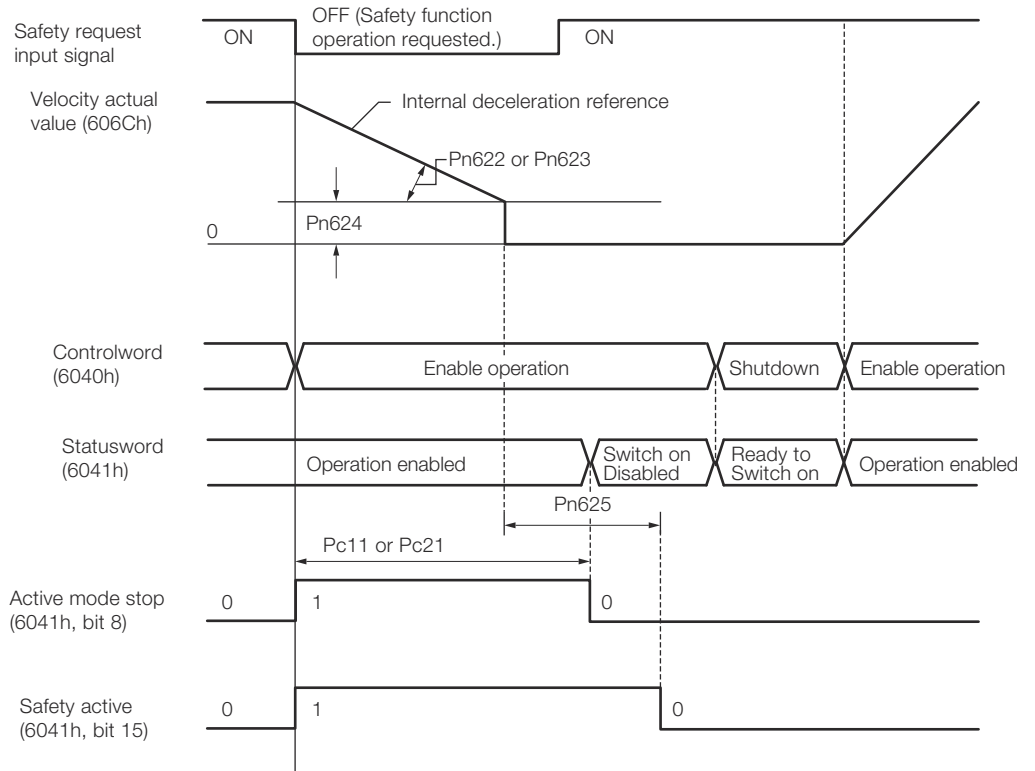


Fig. 355: When Using the SBB-D Function

When Using the SPM-D Function (Position or Speed Control)

The motor is stopped at the set deceleration rate (Pn622 or Pn623) and then the servo is locked (Operation Enabled state).

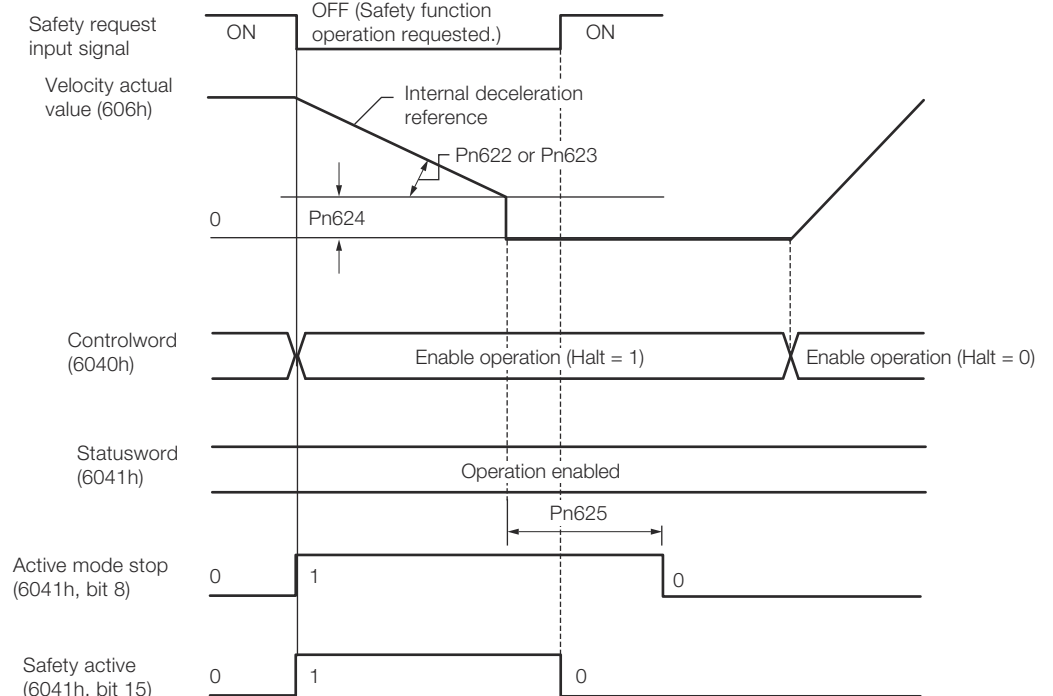


Fig. 356: When Using the SPM-D Function

Operation by Operation Mode When Stopped for the Active Mode Function

Operation Mode	Operation
Profile position mode	Profile position operation is canceled and <i>statusword</i> (6041h) changes as given below. Bit 08 = 1: Active Mode Function operating. Bit 12 = 0: Previous set-point already processed, waiting for new set-point. Bit 15 = 1: Safety function operating.
Homing mode	Homing operation is canceled and <i>statusword</i> (6041h) changes as given below. Bit 08 = 1: Active Mode Function operating. Bit 13 = 1: Homing error. Bit 15 = 1: Safety function operating.
Cyclic synchronous position/ velocity/ torque mode	Cyclic synchronous position, velocity, or torque operation is canceled and <i>statusword</i> (6041h) changes as given below. Bit 08 = 1: Active Mode Function operating. Bit 12 = 0: Target value (position/velocity/torque) ignored. Bit 15 = 1: Safety function operating.
Interpolated position mode	Interpolated position operation is canceled and <i>statusword</i> (6041h) changes as given below. Bit 08 = 1: Active Mode Function operating. Bit 12 = 0: Interpolation operation disabled. Bit 15 = 1: Safety function operating.
Profile velocity/ torque mode	Profile velocity or torque operation is canceled and <i>statusword</i> (6041h) changes as given below. Bit 08 = 1: Active Mode Function operating. Bit 15 = 1: Safety function operating.

Recovery Method

■ Recovery Conditions

If the Active Mode Function operates and the motor is stopped, the Active Mode Function will be reset and normal operation will be enabled when all of the following conditions are met.

- All relevant safety request input signals must be ON.
- A period of time equal to or greater than the value set as the Active Mode Hold Time (Pn625) must have elapsed.
- The following command must have been sent from the Controller.
- Interpolated Position Mode: Bit 8 in *controlword* (6040h) = 1 (stop axis according to *halt option code* (605Dh)) or bit 4 = 0 (disable interpolation).
- Cyclic Synchronous Position/Velocity Mode or Profile Velocity Mode: Bit 8 in *controlword* (6040h) = 1 (Halt).
- Profile Torque or Cyclic Synchronous Torque Mode: Bits 1 and 2 in *controlword* (6040h) = 1 (Shutdown).
- Homing Mode or Profile Position Mode: No condition.



If the HWBB function has turned OFF the servo, normal operation will be enabled when the corresponding safety request input signal turns ON.

■ Recovery Procedure

1. ➤ After detecting that bit 8 in *statusword* (6041h) is 1 (Active Mode Function operating) or that bit 15 is 1 (safety function operating), set bit 8 in *controlword* (6040h) to 1 (stop axis according to *halt option code* (605Dh)).
2. ➤ After detecting that the safety request input signal turned ON, confirm that bit 8 in *statusword* (6041h) is 0 (Active Mode Function operation completed) and that bit 15 is 0 (safety function operation completed), and then specify the Servo ON command (Enable Operation command) in *controlword* (6040h).
3. ➤ Specify a new motion command.

13 PROFINET Communication

13.1 General

PROFINET IO is a real time protocol based on Ethernet. It is used as high level network for industrial automation applications. PROFINET IO is very similar to PROFibus and focuses on the data exchange for programmable controller.

A PROFINET IO network consists of the following devices:

- IO-Controller: This is typically the PLC, which controls the whole application.
- IO-Device: a decentralized IO-Device (e.g. drive, encoder, sensor), which is controlled by the IO-Controller.
- IO-Supervisor: HMI (human machine interface) or PC for diagnostic purposes or commissioning.

The real time channel (RT) is used for IO data and alarm mechanism. In PROFINET IO RT (conformance class A and B), the RT data is transferred via a prioritized Ethernet frame.

No special hardware is required. Due to this prioritization a cycle time of less than 10 ms can be achieved.

PROFINET IO IRT is used for more precise timing requirements. Cycle times of less than 1 ms are possible, but also special hardware for IO-Devices and switches is required.

All diagnostic and configuration data is transferred via the non real time channel (NRT).

For this purpose the common UDP protocol is used. Anyhow, no timing determinism can be guaranteed and typically the cycle times can be more than 100 ms.

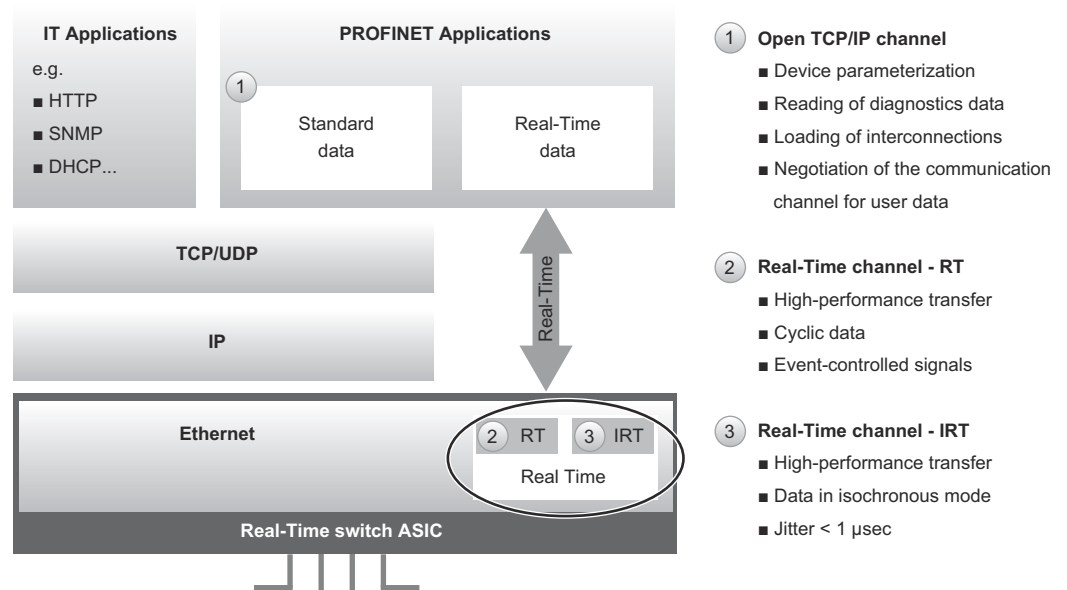


Fig. 357: PROFINET General Overview

13.2 PROFINET Slave Information

The PROFINET IO Slave Information file (GSDML-file, i.e. **General Station Description Markup Language** file) is available for configuring the PROFINET IO-Controller and IO-Supervisor. The XML-based file contains general information about PROFINET communication settings when setting up the SERVOPACK.

The GSDML-file consists of two files:

- GSDML-V□.□□-Yaskawa-SGD7S-□□□AC0□□□□-yyyymmdd.xml
- GSDML-0111-0251-Yaskawa-SGD7S-□□□AC0□□□□_N.bmp

13.3 Application and Communication Relationship (AR, CR)

Every data exchange between an IO-Controller and an IO-Device is embedded into an application relationship (AR). These ARs are used to define communication relationships (CR) with different characteristics for the transfer of parameters, cyclic exchange of data and handling of alarms:

- Record Data CR for the acyclic parameter data exchanger
- IO Data CR for the cyclic process data exchange
- Alarm CR for the real-time transfer of alarm events



Fig. 358: Application and Communication Relationship

13.4 Drive Units (DU) and Drive Objects (DO)

PROFIdrive Base Model

The PROFIdrive Base Model defines as basic elements the following three classes of communication devices:

- Controller

The Controller is a controlling device which is associated with one or more drives (axes). Related to the automation system, the Controller is the host for the overall automation.
- P-Device

The P-Device (peripheral device) is a field device and the host device for the drives (closed loop control, inverter). The P-Device typically is associated with one or more Controller devices.
- Supervisor

The Supervisor typically is an engineering device which manages provisions of configuration data (parameter sets) and collections of diagnosis data from P-Devices and/or Controllers.

Drive Units (DU) and Drive Objects (DO)

If we take a closer look at the P-Device type, we see that the Functional Objects inside the P-Device consist of one or more *Drive Units (DU)* which comprises one or more *Drive Objects (DO)*.

Drive Units (DU) and Drive Objects (DO)

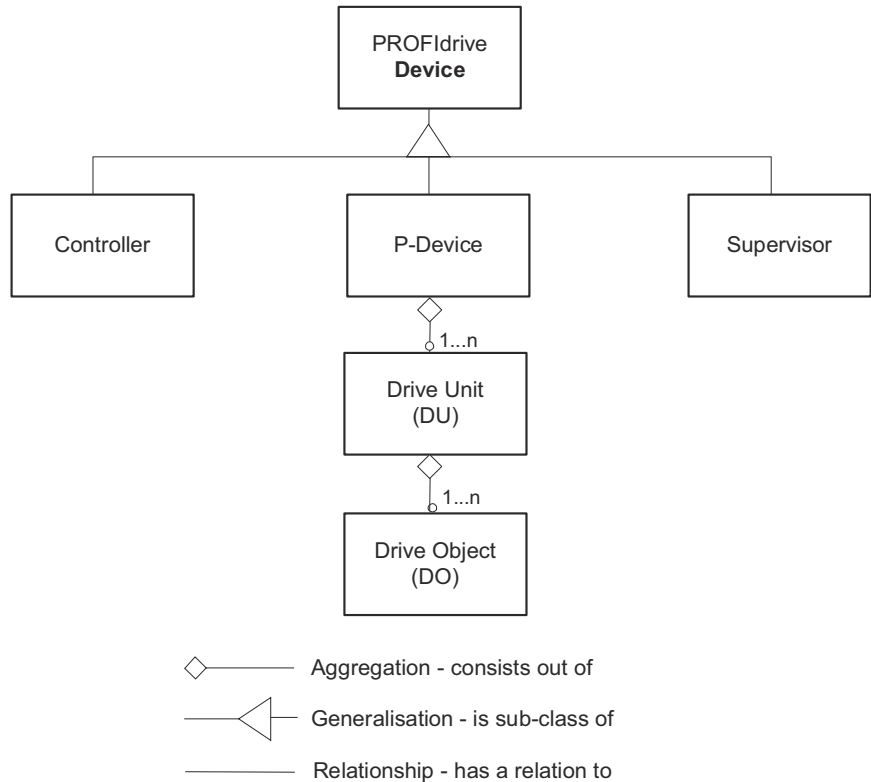


Fig. 359: Hierarchical order in the PROFIdrive Object Model

Clustering the Drive Objects in Drive Units may be used to define the affiliation of Drive Objects to one physical drive control unit (CPU) or physical cluster. The Drive Unit expresses definitely the area of validity of global parameters.

Local parameter access versus Global parameter access

The understanding of this concept is crucial for parameter accesses in multi-axis P-Devices. This is because *global* and *local* accesses are distinguished. A *local access* refers to a special axis (DO), a *global access* refers to the device (DU).

The typical functionality of the Drive Object is the drive functionality itself, i.e. the motion task related parameters (motor, inverter stage, closed loop current and speed control, Input and output functionality). For example, one drive axis is related to a Drive Object.

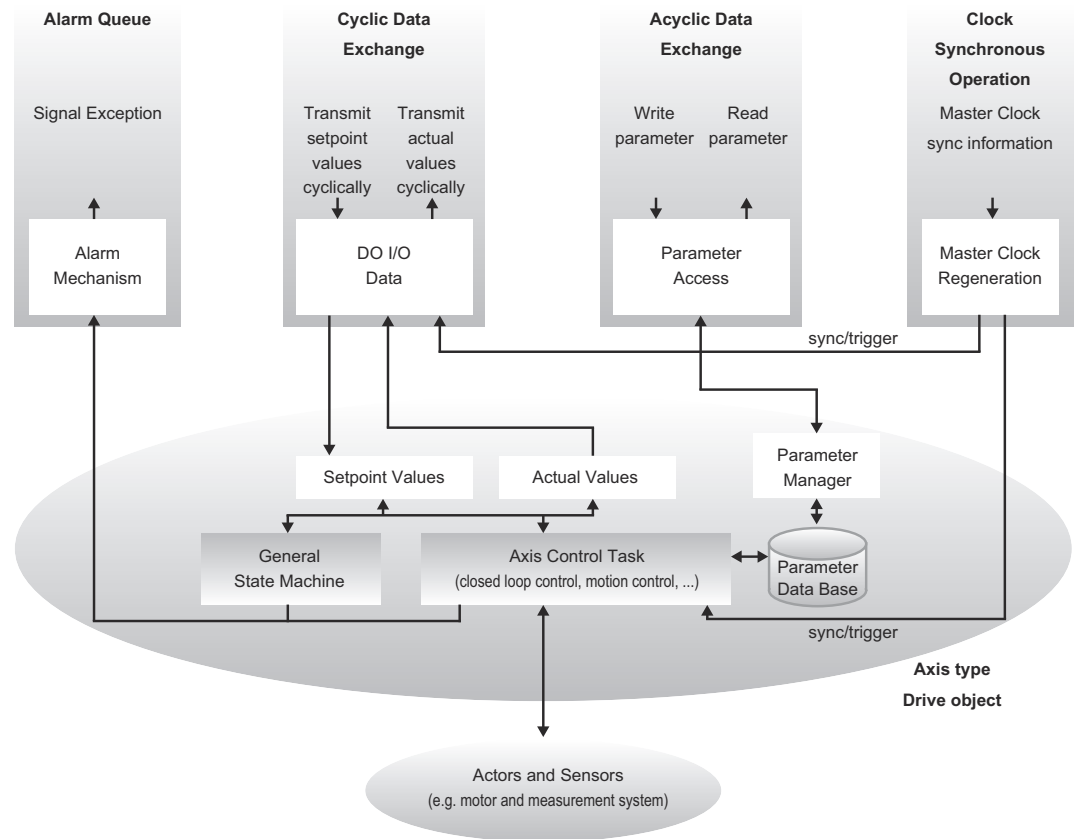


Fig. 360: Drive Object

It contains the following items:

- General state machine
- Axis control task
- Parameter manager with parameter data base

Multiple communication channels are used for read/write data values over PROFINET IO.

The Drive Object can be accessed via:

- Cyclic data exchange
- Acyclic data exchange
- Alarm queue (optional)
- Clock synchronous operation (currently not supported)

The cyclic data exchange includes the transmission/reception of data values like set point values (e.g. Position set point, velocity set point or control word) and actual values (actual position value, actual velocity or status word) between the IO-Controller and the drive object. These values are called IO data and are transferred in real time.

The acyclic data is used for configuring the drive, which typically is not time critical. Each DO has an own parameter manager, which handles the access. PROFINET IO uses the non real time channel for this purpose.

The alarm queue is used for signalling an exceptional situation to the IO-Controller, which is generated through the state machine or the axis control task itself.

The clock synchronous operation requires PROFINET IRT (conformance class C), which is currently not supported.

13.5 Identification and Maintenance Function (I&M)

The purpose of the I&M functions is to provide support for the customer during commissioning, parameterization and repair of the module.

Identification and Maintenance Function (I&M)

The SERVOPACK supports I&M Record data 0 to 3, which can be accessed using the read request of the Record data object:

- I&M 0 - Record Data index AFF0h (Read only)
I&M 0 contains device identification (serial number, version number, order no., manufacturer etc.)
- I&M 1 - Record Data index AFF1h (Read/Write)
I&M 1 contains tag for function and location of the PROFINET device.
- I&M 2 - Record Data index AFF2h (Read/Write)
I&M 2 contains current date and time (installation date) of the PROFINET device.
- I&M 3 - Record Data index AFF3h (Read/Write)
I&M 3 contains a descriptor (description of the function) of the PROFINET device.

I&M 0 Data

Content	Size	Description	Comment
Header	6 bytes	-	-
Vendor ID	2 bytes	PROFINET Vendor ID	YASKAWA (0111h)
Order ID	20 bytes	-	-
Serial number	16 bytes	Serial number of the SERVOPACK	SGD7S-□□□□C0□□
Hardware revision	2 bytes	Revision of the hardware	Example: 0001h
Software revision	4 bytes	Revision of the software	V200
Revision counter	2 bytes	Counts the changes of I&M 1 to I&M 4 objects	Example: 0000h
Profile ID	2 bytes	Profile ID of item	PROFIdrive (3A00h)
Profile specific type	2 bytes	Additional profile information	no profile specific type (0000h)
I&M version	2 bytes	Version of I&M data	Version 1.1 (0101h)
Supported I&M functions	2 bytes	Bitmask of supported I&M objects	I&M0-3: 000E

The I&M 0 data structure is used to provide an IO-Controller with general information about the module or device.

I&M 1 Data

Content	Size	Description
Header	6 bytes	-
Function	32 bytes	Description of the function or purpose of the module or device (Example: "Pressure sensor 7"). The string is padded to the maximum length.
Location	22 bytes	Description of the location (Example: "Production plant 3"). The string is padded to the maximum length.

The I&M 1 data structure is used to inform an IO-Controller of the function and location of the module or device.

I&M 2 Data

Content	Size	Description
Header	6 bytes	-
Installation Date	16 bytes	Installation date in the format YYYY-MM-DD hh:mm (Example: "2018-11-14 10:02") The string is padded to the maximum length.
Reserved	38 bytes	

The I&M 2 data structure is used to inform an IO-Controller of the installation date of the module or device.

I&M 3 Data

Content	Size	Description
Header	6 bytes	-
Descriptor	54 bytes	Individual additional information about the module or device (Example: "Replaced on 2018-11-14 10:06") The string is padded to th maximum length.

The I&M 3 data structure is used to inform an IO-Controller of individual additional information about the module or device.

Telegrams > Standard Speed Telegram (ST1)

13.6 Telegrams

13.6.1 Supported Telegrams

The SERVOPACK supports PROFIdrive standard telegrams for speed mode and position mode. Further on, a YASKAWA manufacturer specific telegram can be selected. It is also possible to configure the cyclic communication. See the following table for details.

Telegram	Telegram number	Operation Modes	Description
ST1 (Standard Telegram 1)	1	Velocity Control Pole Detection	Default setting
ST2 (Standard Telegram 2)	2	Velocity Control Pole Detection	
ST7 (Standard Telegram 7)	7	Position Control Pole Detection	
ST9 (Standard Telegram 9)	9	Position Control Pole Detection	
YASKAWA telegram	100	Position Control Velocity Control Torque Control Pole Detection	
Free configurable telegram	999	Position Control Velocity Control Torque Control Pole Detection	

A change of the telegram configuration will be activated during the initialization phase of the SERVOPACK, i.e.:

- The settings have to be stored in non-volatile memory of the PROFINET module (PNU 977)
- The SERVOPACK has to be re-initialized by one of the following options:
 - Command drive reset (PNU 972)
 - Power cycle SERVOPACK

13.6.2 Standard Speed Telegram (ST1)

Operating mode PNU 930	<ul style="list-style-type: none"> ■ 0001h (PROFIdrive velocity mode) ■ 80FFh (Pole detection mode) 	
Modes of Operation (6060h, 6061h)	<ul style="list-style-type: none"> ■ -3 (PROFIdrive velocity mode) ■ -1 (Pole detection mode) 	
Telegram	1	
Application Class	1	
PZD 1	Controlword 1 (STW1)	Statusword 1 (ZSW1)
PZD 2	Speed Setpoint A (NSOLL_A)	Speed Actual Value A (NIST_A)

Related objects

Object	Index (hex)	Pn No.	Units, Scaling	Info
STW1	6040h	B11	-	-
ZSW1	6041h	B12	-	-
NSOLL_A	2505h	BB2	4000h ⇒ 100% of (607Fh/2)	Connected to 60FFh (Vel. units)
NIST_A	2506h	BB3	4000h ⇒ 100% of (607Fh/2)	Connected to 606Ch (Vel. units)

13.6.3 Standard Speed Telegram (ST2)

Operating mode PNU 930	<ul style="list-style-type: none"> ■ 0001h (PROFIdrive velocity mode) ■ 80FFh (Pole detection mode) 	
Modes of Operation (6060h, 6061h)	<ul style="list-style-type: none"> ■ -3 (PROFIdrive velocity mode) ■ -1 (Pole detection mode) 	
Telegram	2	
Application Class	1	
PZD 1	Controlword 1 (STW1)	Statusword 1 (ZSW1)
PZD 2	Speed Setpoint B (NSOLL_B)	Speed Actual Value B (NIST_B)
PZD 3		
PZD 4	Controlword 2 (STW2)	Statusword 2 (ZSW2)

Related objects

Object	Index (hex)	Pn No.	Units, Scaling	Info
STW1	6040h	B11	-	-
ZSW1	6041h	B12	-	-
STW2	2503h	BB0	-	-
ZSW2	2504h	BB1	-	-
NSOLL_B	2507h	BB4	40000000h ⇒ 100% of (607Fh/2)	Connected to 60FFh (Vel. units)
NIST_B	2508h	BB6	40000000h ⇒ 100% of (607Fh/2)	Connected to 606Ch (Vel. units)

13.6.4 Standard Position Telegram (ST7)

Operating mode PNU 930	<ul style="list-style-type: none"> ■ 0002h (PROFIdrive position mode) (Program submode) ■ 80FFh (Pole detection mode)
Modes of Operation (6060h, 6061h)	<ul style="list-style-type: none"> ■ -2 (PROFIdrive position mode) (Program submode) ■ -1 (Pole detection mode)
Telegram	7
Application Class	3

Telegrams > Standard Position Telegram (ST9)

PZD 1	Controlword 1 (STW1)	Statusword 1 (ZSW1)
PZD 2	Traversing Block Selection (SATZANW)	Actual Traversing Block (AKTSATZ)

Related objects

Object	Index (hex)	Pn No.	Units, Scaling	Info
STW1	6040h	B11	-	-
ZSW1	6041h	B12	-	-
SATZANW	2532h	BD0	-	-
AKTSATZ	2533h	BD1	-	-

13.6.5 Standard Position Telegram (ST9)

Operating mode PNU 930	<ul style="list-style-type: none"> ■ 0002h (PROFIdrive position mode) (MDI submode, Program submode) ■ 80FFh (Pole detection mode) 	
Modes of Operation (6060h, 6061h)	<ul style="list-style-type: none"> ■ -2 (PROFIdrive position mode) (MDI submode, Program submode) ■ -1 (Pole detection mode) 	
Telegram	9	
Application Class	3	
PZD 1	Controlword 1 (STW1)	Statusword 1 (ZSW1)
PZD 2	Traversing Block Selection (SATZANW)	Actual Traversing Block (AKTSATZ)
PZD 3	Controlword 2 (STW2)	Statusword 2 (ZSW2)
PZD 4	Target Position (MDI_TARPOS)	Position Actual Value (XIST_A)
PZD 5		
PZD 6	Profile Velocity (MDI_VELOCITY)	
PZD 7		
PZD 8	MDI Acceleration (MDI_ACC)	
PZD 9	MDI Deceleration (MDI_DEC)	
PZD 10	MDI Mode (MDI_MOD)	

Related objects

Object	Index (hex)	Pn No.	Units, Scaling	Info
STW1	6040h	B11	-	-
ZSW1	6041h	B12	-	-
STW2	2503h	BB0	-	-
ZSW2	2504h	BB1	-	-
XIST_A	6064h	B24	Pos. unit	-
SATZANW	2532h	BD0	-	-

Object	Index (hex)	Pn No.	Units, Scaling	Info
AKTSATZ	2533h	BD1	-	-
MDI_TARPOS	607Ah	B40	Pos. unit	-
MDI_VELOCIT Y	6081h	B4E	Vel. unit	-
MDI_ACC	2536h	BD2	FFFFh ⇔ 100% of 60C5h	Connected to 6083h (Acc. unit)
MDI_DEC	2537h	BD3	FFFFh ⇔ 100% of 60C6h	Connected to 6084h (Acc. unit)
MDI_MOD	2538h	BD4	-	-

13.6.6 YASKAWA Telegram (Telegram 100)

Operating mode PNU 930	<ul style="list-style-type: none"> ■ 0001h (PROFIdrive velocity mode) ■ 0002h (PROFIdrive position mode) (MDI submode, Program submode) ■ 80FFh (Pole detection mode) ■ 8004h (Profile Torque Mode) 		
Modes of Operation (6060h, 6061h)	<ul style="list-style-type: none"> ■ -3 (PROFIdrive velocity mode) ■ -2 (PROFIdrive position mode) (MDI submode, Program submode) ■ -1 (Pole detection mode) ■ 4 (Profile Torque Mode) 		
Telegram	100		
Application Class	1, 3		
PZD 1	Controlword 1 (STW1)	Statusword 1 (ZSW1)	
PZD 2	Traversing Block Selection (SATZANW)	Actual Traversing Block (AKTSATZ)	
PZD 3	Controlword 2 (STW2)	Statusword 2 (ZSW2)	
PZD 4	Modes of Operation	Modes of Operation Display	
PZD 5	Target Position (MDI_TARPOS)	Position Actual Value (XIST_A)	
PZD 6			
PZD 7	Target Velocity	Velocity Actual Value	
PZD 8			
PZD 9	Target Torque	Torque Actual Value	
PZD 10	Touch Probe Function	Touch Probe Status	
PZD 11	Profile Acceleration	Touch Probe Value	
PZD 12			
PZD 13	Profile Deceleration	Following Error Actual Value	
PZD 14			
PZD 15	Profile Velocity (MDI_VELOCITY)		
PZD 16			

Telegrams > Free Configurable Telegram (Telegram 999)

Related objects

Object	Index (hex)	Pn No.	Units, Scaling	Info
STW1	6040h	B11	-	-
ZSW1	6041h	B12	-	-
STW2	2503h	BB0	-	-
ZSW2	2504h	BB1	-	-
SATZANW	2532h	BD0	-	-
AKTSATZ	2533h	BD1	-	-
Modes of Operation	6060h	B18	-	-
Modes of Operation Display	6061h	B19	-	-
Position Actual Value	6064h	B24	Pos. unit	-
Target Position	607Ah	B40	Pos. unit	-
Profile Velocity	6081h	B4E	Vel. unit	Used for PROFIdrive position mode (MDI submode)
Velocity Actual Value	606Ch	B30	Vel. unit	-
Target Torque	6071h	B36	Per thousand of related torque	Used for Profile Torque Mode
Torque Actual Value	6077h	B3E	Per thousand of related torque	-
Profile Acceleration	6083h	B50	Acc. unit	Used for PROFIdrive position mode (MDI submode) and PROFIdrive velocity mode
Profile Deceleration	6084h	B52	Acc. unit	Used for PROFIdrive position mode (MDI submode) and PROFIdrive velocity mode
Following Error Actual Value	60F4h	B84	Pos. unit	-
Target Velocity	60FFh	B8E	Vel. unit	Used for PROFIdrive velocity mode
Touch Probe Function	60B8h	B64	-	-
Touch Probe Status	60B9h	B66	-	-
Touch Probe Value	60BAh	B68	Pos. unit	-

13.6.7 Free Configurable Telegram (Telegram 999)

The PZDs 2 to 16 can be freely selected. See [↔ Chap. 13.7 'IO Data Signals' ...page 470](#) for parameters to be selected.

If this telegram is used, a PZD length in a range of 1 to 16 PZDs can be used.



- Please note that to activate telegram 999 if another telegram is active, the sequence described in [↔ Chap. 13.6.1 'Supported Telegrams' ...page 464](#) to change a telegram has to be performed.
- If telegram 999 is active and the mapping is to be changed, the cyclic data are marked as invalid by writing telegram number 0.
- If telegram 999 was active, a change of the telegram mapping is active immediately after activation (PNU 922 = 999).

Example

- Current telegram configuration: Standard telegram 1 (ST1)
- New telegram configuration: Free configurable telegram (with changed mapping)
- Sequence to change telegram configuration and mapping of the free configurable telegram:
 - Set PNU 922 to "999"
 - Store configuration in non-volatile memory
 - Perform "drive reset" to re-initialize SERVOPACK
⇒ telegram 999 with last used telegram mapping is active (default: All PZDs "0").
 - Set PNU 922 to "0"
 - Change mapping of set points/actual values with PNU 915 and PNU 916

Example for Positioning Axis:

Set PNU 915|0 to 6040h (Controlword 1) (Note: PZD1 is required to be Controlword 1)

Set PNU 915|1 to 2532h (Traversing Block Selection)

Set PNU 915|2 to 2538h (MDI Mode)

Set PNU 915|3 to 607Ah (Target Position)

Set PNU 915|4 to 607Ah (Target Position)

Set PNU 915|5 to 6081h (Profile Velocity)

Set PNU 915|6 to 6081h (Profile Velocity)

Set PNU 915|7 to 6083h (Profile Acceleration)

Set PNU 915|8 to 6083h (Profile Acceleration)

Set PNU 915|9 to 6084h (Profile Deceleration)

Set PNU 915|A to 6084h (Profile Deceleration)

Set PNU 916|0 to 6041h (Statusword 1) (Note: PZD1 is required to be Statusword 1)

Set PNU 916|1 to 2533h (Actual Traversing Block)

Set PNU 916|2 to 6064h (Position Actual Value)

Set PNU 916|3 to 6064h (Position Actual Value)

Set PNU 916|4 to 606Ch (Velocity Actual Value)

Set PNU 916|5 to 606Ch (Velocity Actual Value)

Set PNU 916|6 to 6077h (Torque Actual Value)
- Set PNU 922 to "999"
- ⇒ First it is checked whether the configured mapping is valid, and if so, telegram 999 is activated with the new mapping. Otherwise there is an error message if PNU 922 is to be set to 999.

IO Data Signals

Operating mode PNU 930	<ul style="list-style-type: none"> ■ 0001h (PROFIdrive velocity mode) ■ 0002h (PROFIdrive position mode) (MDI sub-mode, Program submode) ■ 80FFh (Pole detection mode) ■ 8004h (Profile Torque Mode) 	
Mode of Operation (6060h, 6061h)	<ul style="list-style-type: none"> ■ -3 (PROFIdrive velocity mode) ■ -2 (PROFIdrive position mode) (MDI submode, Program submode) ■ -1 (Pole detection mode) ■ 4 (Profile Torque Mode) 	
Telegram	999	
Application Class	1, 3	
PZD 1	Controlword 1 (STW1)	Statusword 1 (ZSW1)
PZD 2 to PZD 16	Freely selectable	Freely selectable

13.7 IO Data Signals

The following table provides an overview of the values to be used for the free configurable telegram 999.

Signal No.	Significance	Abbreviation	TPZD / RPZD (**)	Data Type (*)	Normalization	Interconnection parameter Normalized (Not normalized)
1	Controlword 1	STW1	RPZD	UINT		6040h
2	Statusword 1	ZSW1	TPZD	UINT		6041h
3	Controlword 2	STW2	RPZD	UINT		2503h
4	Statusword 2	ZSW2	TPZD	UINT		2504h
5	Speed Setpoint A	NSOLL_A	RPZD	INT(N2)	4000h ⇔ 100% of (607Fh/2)	2505h (60FFh)
6	Speed Actual Value A	NIST_A	TPZD	INT(N2)		2506h (606Ch)
7	Speed Setpoint B	NSOLL_B	RPZD	DINT(N4)	40000000h ⇔ 100% of (607Fh/2)	2507h (60FFh)
8	Speed Actual Value B	NIST_B	TPZD	DINT(N4)		2508h (606Ch)
21	Digital Input	E_DIGITAL	TPZD	UINT		2521h
22	Digital Output	A_DIGITAL	RPZD	UINT		2522h
28	Position Actual Value	XIST_A	TPZD	DINT		6064h
32	Traversing Block Selection	SATZANW	RPZD	UINT		2532h
33	Actual Traversing Block	AKTSATZ	TPZD	UINT		2533h
34	Target Position	MDI_TARPOS	RPZD	DINT		607Ah
35	Profile Velocity	MDI_VELOCITY	RPZD	UDINT		6081h
36	MDI Acceleration	MDI_ACC	RPZD	UINT(X2)	FFFFh ⇔ 100% of 60C5h	2536h (6083h)
37	MDI Deceleration	MDI_DEC	RPZD	UINT(X2)	FFFFh ⇔ 100% of 60C6h	2537h (6084h)
38	MDI Mode	MDI_MOD	RPZD	UINT		2538h

Signal No.	Significance	Abbreviation	TPZD / RPZD (**)	Data Type (*)	Normalization	Interconnection parameter Normalized (Not normalized)
100	Modes of Operation		RPZD	INT		6060h
101	Modes of Operation Display		TPZD	INT		6061h
102	Position Demand Value		TPZD	DINT		6062h
103	Position Actual Internal Value		TPZD	DINT		6063h
104	Velocity Demand Value		TPZD	DINT		606Bh
105	Velocity Actual Value		TPZD	DINT		606Ch
106	Target Torque		RPZD	INT		6071h
107	Torque Demand		TPZD	INT		6074h
108	Torque Actual Value		TPZD	INT		6077h
109	Profile Acceleration		RPZD	UDINT		6083h
110	Profile Deceleration		RPZD	UDINT		6084h
111	Torque Slope		RPZD	UDINT		6087h
112	Touch Probe Function		RPZD	UINT		60B8h
113	Touch Probe Status		TPZD	UINT		60B9h
114	Touch Probe 1 Position Value		TPZD	DINT		60BAh
115	Touch Probe 2 Position Value		TPZD	DINT		60BCh
116	Positive Torque Limit Value		RPZD	UINT		60E0h
117	Negative Torque Limit Value		RPZD	UINT		60E1h
118	Following Error Actual Value		TPZD	DINT		60F4h
119	Position Demand Internal Value		TPZD	DINT		60FCh
120	Target Velocity		RPZD	DINT		60FFh
121	Target Position in Range		TPZD	DINT		2401h
122	Actual Position in Range		TPZD	DINT		2402h
123	Error Code		TPZD	UINT		603Fh
124	Safety Module Monitors	Safety	TPZD	UDINT		2410h

(*) N2,N4 - Data normalized according to PROFIdrive N2,N4 data normalization. This means e.g. NSOLL_A (2505h) = 4000h is 100% of Max. Profile Velocity (607Fh) / 2.

X2 - Data normalized according to PROFIdrive X2 data normalization. X=16. This means e.g. MDI_ACC (2536h) = FFFFh is 100% of Max. Acceleration (60C5h).

(**) Standard PZD direction

14 PROFdrive Drive Profile

14.1 Device Control

The device control of the SERVOPACK can be used to carry out all the motion functions in the corresponding modes. The state machine is controlled through the Controlword STW1 (6040h). The status of the state machine can be revealed by using the Statusword ZSW1 (6041h).

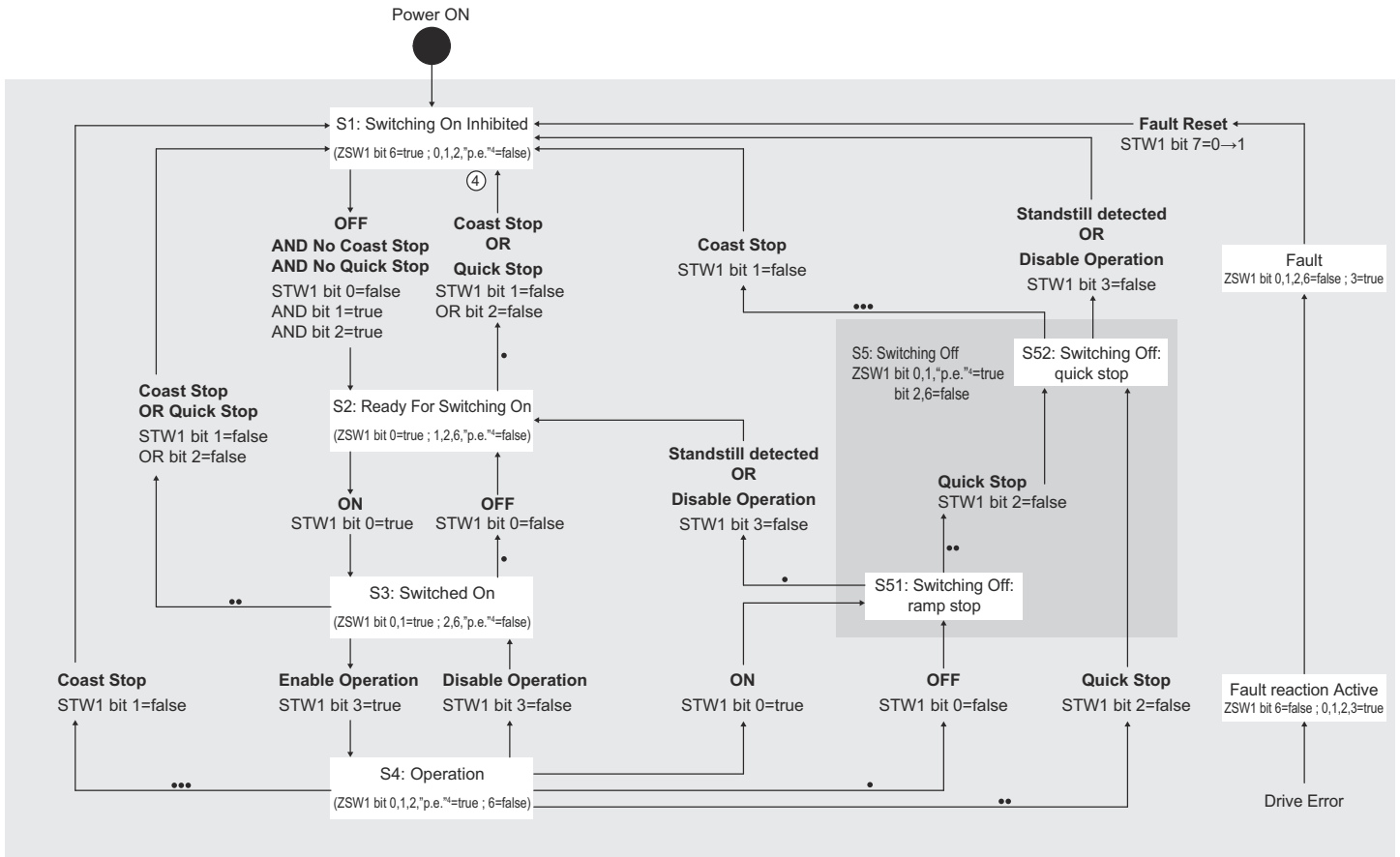


Fig. 361: PROFdrive General State Machine

- 1 STW1 bit x,y means these Controlword bits shall be set by the controller
- 2 ZSW1 bit x,y means these Statusword bits indicate the actual state
- 3 "Standstill detected" is an internal result of a stop operation
- 4 "p.e." means "Pulses enabled" (not supported)
- 5 The more dots are on a line, the higher is the priority
- 6 The Fault reactions are performed according to the Fault Reaction Option Code (605Eh).
Note: In case of a group 1 alarm or group 2 alarm the stopping method is based on Pn001.0 and Pn00B.1 parameter setting.

State Machine Control Commands → Chap. 15.6 'Device Control' ...page 512

Bits in PROFINET Statusword ZSW1 (6041h) → Chap. 15.6 'Device Control' ...page 512

Related Objects

Index (hex)	Sub	Pn No.	Name	Access	PDO Mapping	Default value	Units	Type
6040h	0	B11	Controlword 1 (STW1)	RW	RPZD	0	–	UINT
6041h	0	B12	Statusword 1 (ZSW1)	RO	TPZD	–	–	UINT
605Ah	0	B13	Quick Stop Option Code	RW	No	2 (Slow down on quick stop ramp)	–	INT
605Dh	0	B16	Halt Option Code	RW	No	3 (Slow down on max. deceleration (60C6h))	–	INT
605Eh	0	B17	Fault Reaction Option Code	RW	No	2 (Slow down on quick stop ramp and turn the servo off)	–	INT
6060h	0	B18	Modes of Operation	RW	RPZD	0 (no operation mode)	–	INT
6061h	0	B19	Modes of Operation Display	RO	TPZD	–	–	INT
2503h	0	BB0	Controlword 2 (STW2)	RW	RPZD	0	–	UINT
2504h	0	BB1	Statusword 2 (ZSW2)	RO	TPZD	–	–	UINT

Unconfigurable PROFIdrive State Machine Stop Action

Transitions	Transitions State	Action (*)
Ramp Stop	S4 → S5	Slow down with the current Profile deceleration (6084h). Note: The deceleration in PROFIdrive Velocity Mode depends on STW1 bit 4: <ul style="list-style-type: none"> ■ STW1 bit 4=0: Profile deceleration is according to Parameter 605Dh (Default: 605Dh = Max. Deceleration) ■ - STW1 bit 4=1: Profile deceleration (6084h)
Coast Stop	S4 → S1	Servo off - Determined by Sigma-7 Pn001.0
Disable operation	S4 → S3	Servo off - Determined by Sigma-7 Pn001.0
Fault reaction active	S4 → S1	The Fault reactions are performed according to the Fault Reaction Option Code (605Eh). Note: In case of a group 1 alarm or group 2 alarm the stopping method is based on Pn001.0 and Pn00B.1 parameter setting.

(*) The Servo off stopping method is determined by SERVOPACK Pn001.0. The Sigma-7 factory default setting is Stop by dynamic brake (Pn001.0=0) and for PROFIdrive standard compliance the setting should be Pn001.0=2 Coast stop.

14.2 Modes of Operation

The SERVOPACK supports the following modes of operation:

- PROFIdrive Profile Position mode
- PROFIdrive Profile Velocity mode
- Profile Torque Mode
- Pole Detection mode

Related Objects

Index (hex)	PNU (dec)	Sub	Pn No.	Name	Access	PDO Mapping	Default value	Units	Type
6060h		0	B18	Modes of Operation	RW	RPZD	0 (no operation mode)	–	INT
6061h		0	B19	Modes of Operation Display	RO	TPZD	–	–	INT
	930	0	–	PROFIdrive Operating Mode	RO	No	–	–	UINT

Dynamic Mode Change

The operation mode can be switched by writing the object 6060h. The master has the responsibility to update all operation mode specific process data objects together with the selection of the operation mode at the same time.

If the master selects a new operation mode, the SERVOPACK changes to the new operation mode immediately.

The following table shows the behavior when changing to a new operation mode from the other mode.

New Operation Mode	Behavior when Changing to a New Operation Mode
PROFIdrive Position mode	<p>Active operation mode: PROFIdrive velocity mode</p> <ul style="list-style-type: none"> ■ Operation mode is changed, but motor will be stopped with configured profile deceleration (6084h). A new positioning can only be started when the motor has come to a standstill. Then the positioning can be started with rising edge of STW1 bit 6 (Activate Traversing Task). <p>Active operation mode: Profile Torque Mode</p> <ul style="list-style-type: none"> ■ Motor will decelerate with configured torque slope (6087h). A new positioning can only be started when the motor has come to a standstill. Then the positioning can be started with rising edge of STW1 bit 6 (Activate Traversing Task).
PROFIdrive velocity mode	New operation mode will be started immediately.
Profile Torque Mode	New operation mode will be started immediately.

14.3 PROFIdrive Position Mode

14.3.1 Overview

The PROFIdrive position mode is used to start positioning to the target position with the profile velocity, the profile acceleration and the profile deceleration. The following figure shows the block diagram of the PROFIdrive position mode. Refer to the following chapters for details on both available position submodes:

- MDI submode
- Program submode

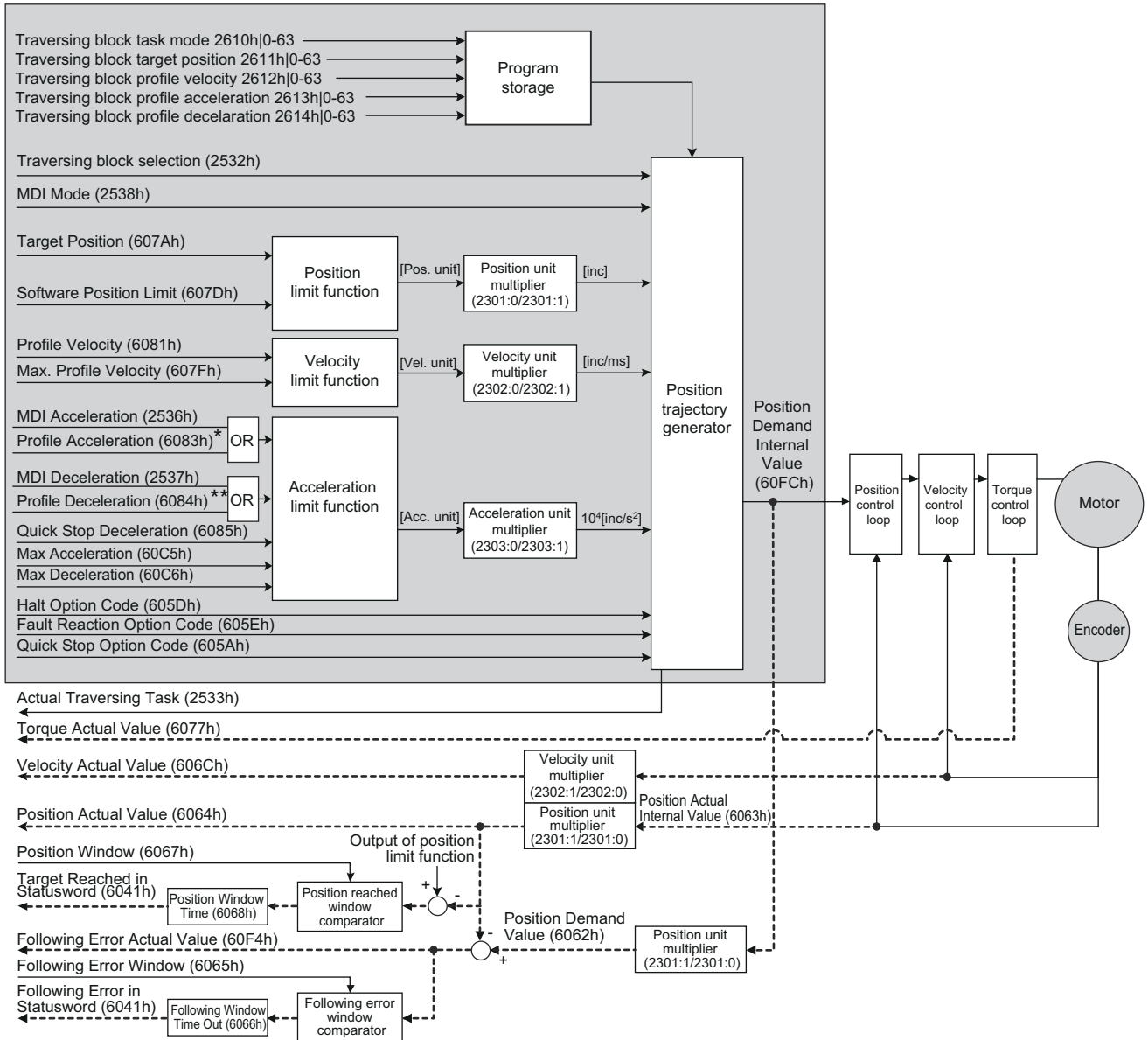


Fig. 362: PROFIdrive Position Mode

Extended State diagram of the Position Mode

The following figure shows the state diagram of the Profile Position mode. This state diagram is only valid in state "S4: Operation" of the General State Diagram.

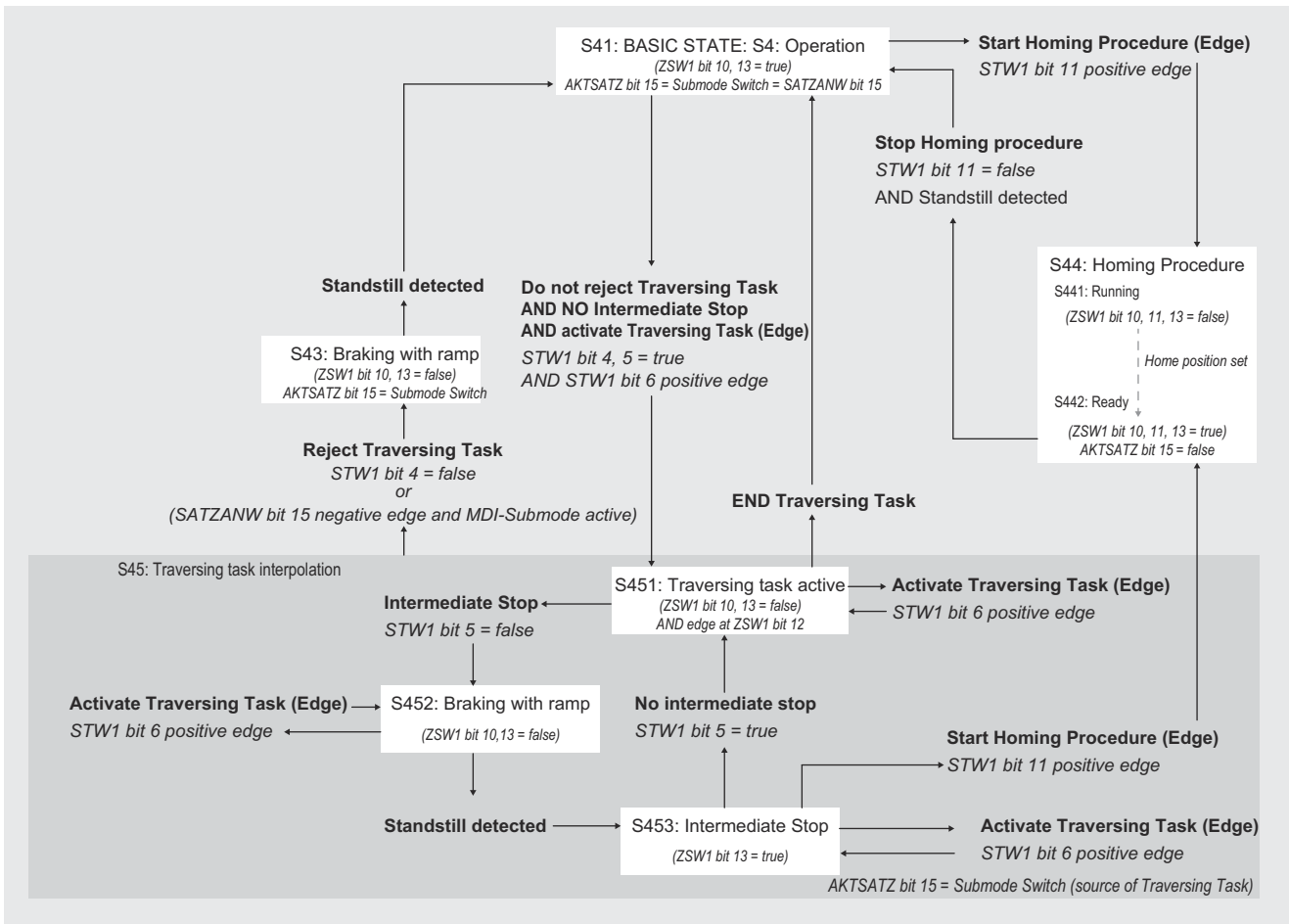


Fig. 363: PROFIdrive Position Mode Extended State Diagram

PROFdrive Position Submodes “MDI” and “Program”

This SERVOPACK supports both submodes “Manual Data Input” (MDI) and “Program”.

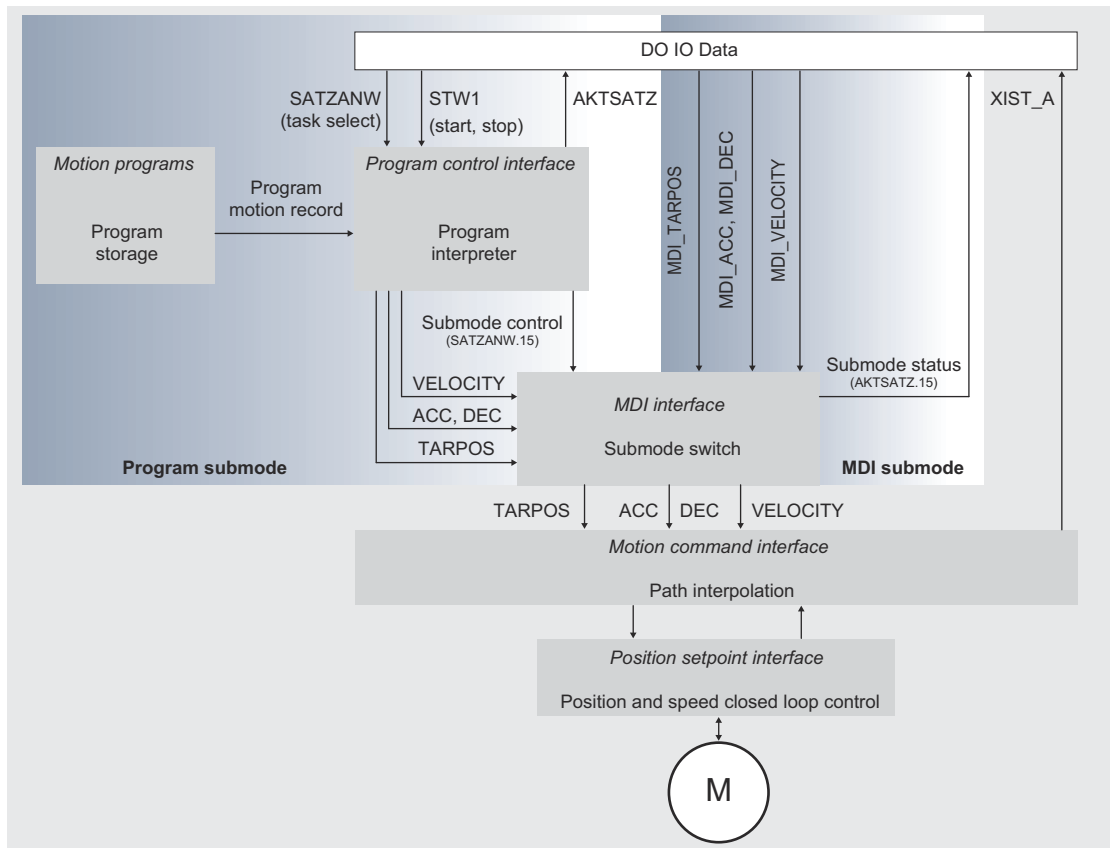


Fig. 364: Program Submode and MDI Submode

14.3.2 MDI Submode

The motion controller for *Manual Data Input* (MDI) submode comprises in addition to the Program submode components also a submode switch which enables the direct access to the motion command interface from the DO IO Data without using the program interpreter. This results in the advantage of immediate control of the motion command interface by the controller via DO IO DATA.

Activation / Deactivation of the MDI submode

Changeover from the program execution to the MDI interface and vice versa is controlled by Bit 15 of Traversing Block Selection (SATZANW) (2532h):

- Bit 15 = 1
Activation of the MDI submode. If there is a program still running (extended state machine not in the Basic State), the positioning interface will change to MDI Submode only after the program ends or is terminated (STW1 bit 4).
- Bit 15 = 0
Deactivation of the MDI submode. If there is a MDI motion command still executed the path interpolation shall stop and the MDI motion command shall be rejected.

If MDI submode is active, the input for the motion command interface of the path interpolator will be taken out of the signals *Target Position*, *Acceleration*, *Deceleration* and *Velocity*. These values get valid as input for the calculation of a new path from the actual axis position to the new target position with the rising edge of STW1 bit 6. Controlling of the motion process is done by the dedicated bits of STW1 out of the DO IO Data.

The signal *Acceleration* defines the acceleration of the motion at the beginning of the path, while the signal *Deceleration* defines the deceleration at the end of the path (independent of the absolute motion direction).



By using Controlword 2 (STW2) it is possible to control "relative" or "absolute" positioning without acyclic parameter access:

- STW2.0 (Absolute / Relative positioning mode)
 - 0 = Relative positioning (from Actual Position)
 - 1 = Absolute positioning
- STW2.10 (STW2 Control override)
 - 0 = STW2 control override is disabled (e.g. standard behavior Absolute / Relative motion is determined by MDI Mode (MDI_MOD.0))
 - 1 = STW2 control override is enabled (e.g. Absolute / Relative motion is determined by Controlword 2 (STW2.0))

Related Objects

Index (hex)	Sub	Pn No.	Name	Access	PDO Mapping	Default value	Units	Type
6040h	0	B11	Controlword 1(STW1)	RW	RPZD	0	-	UINT
6041h	0	B12	Statusword 1 (ZSW1)	RO	TPZD	-	-	UINT
2503h	0	BB0	Controlword 2 (STW2)	RW	RPZD	0	-	UINT
2504h	0	BB1	Statusword 2 (ZSW2)	RO	TPZD	-	-	UINT
2532h	0	BD0	Traversing Block Selection (SATZANW)	RW	RPZD	0	-	UINT
2533h	0	BD1	Actual Traversing Block (AKTSATZ)	RO	TPZD	0	-	UINT
2536h	0	BD2	MDI Acceleration (MDI_ACC)	RW	RPZD	0	N2	UINT
2537h	0	BD3	MDI Deceleration (MDI_DEC)	RW	RPZD	0	N2	UINT
2538h	0	BD4	MDI Mode (MDI_MOD)	RW	RPZD	0	-	UINT
607Ah	0	B40	Target Position (MDI_TARPOS)	RW	RPZD	0	Pos. units	DINT
607Dh	-		Software Position Limit	-	-	-	-	-
	0	B48	Min. Position Limit	RW	No	80000000h	Pos. units	DINT
	1	B4A	Max. Position Limit	RW	No	7FFFFFFFh	Pos. units	DINT
607Fh	0	B4C	Max. Profile Velocity	RW	No	Max. motor speed	Vel. units	UDINT
6081h	0	B4E	Profile Velocity (MDI_VELOCITY)	RW	RPZD	0	Vel. units	UDINT
6077h	0	B3E	Torque Actual Value	RO	TPZD	0	0.1 %	INT
606Ch	0	B30	Velocity Actual Value	RO	TPZD	0	Vel. units	DINT
6063h	0	B22	Position Actual Internal Value	RO	TPZD	-	Inc	DINT
6064h	0	B24	Position Actual Value	RO	TPZD	-	Pos. units	DINT
6062h	0	B20	Position Demand Value	RO	TPZD	0	Pos. units	DINT
6083h	0	B50	Profile Acceleration	RW	RPZD	0	Acc. units	UDINT

Index (hex)	Sub	Pn No.	Name	Access	PDO Mapping	Default value	Units	Type
6084h	0	B52	Profile Deceleration	RW	RPZD	0	Acc. units	UDINT
6085h	0	B54	Quick Stop Deceleration	RW	RPZD	Max. motor acceleration	Acc. units	UDINT
60C5h	0	B7C	Max. Acceleration	RW	No	Max. motor acceleration	Acc. units	UDINT
60C6h	0	B7E	Max. Deceleration	RW	No	Max. motor acceleration	Acc. units	UDINT
605Ah	0	B13	Quick Stop Option Code	RW	No	2 (Slow down on quick stop ramp)	-	INT
605Dh	0	B16	Halt Option Code	RW	No	3 (Slow down on Max. Deceleration (60C6h))	-	INT
606Bh	0	B2E	Velocity Demand Value	RO	TPZD	0	Vel. units	DINT
6067h	0	B2A	Position Window	RW	No	0	Pos. units	UINT
6068h	0	B2C	Position Window Time	RW	No	0	ms	UINT
6065h	0	B26	Following Error Window	RW	No	0	Pos. units	UINT
6066h	0	B28	Following Window Timeout	RW	No	0	ms	
60F4h	0	B84	Following Error Actual Value	RO	TPZD	0	Pos. units	DINT
60FCh	0	B86	Position Demand Internal Value	RO	TPZD	0	Inc	DINT
2400h*	0	BA0	Position Range Limit Designation	RW	No	0	-	UINT
2401h	0	BA2	Target Position in Range	RO	TPZD	0	Pos. units	DINT
2402h	0	BA4	Actual Position in Range	RO	TPZD	0	Pos. units	DINT
607Bh*	-		Position Range Limit	-	-	-	-	-
	0	B42	Min. Position Range Limit	RW	No	80000000h	Pos. units	DINT
	1	B44	Max. Position Range Limit	RW	No	7FFFFFFFh	Pos. units	DINT

14.3.3 Program Submode

The motion controller for Program submode consists out of the position closed loop control, the path interpolation, the program interpreter and the program storage (see figure below). The path interpolation cyclically generates position setpoints for the position closed loop control of the axis. The input to the path interpolation is a motion command which consists out of the new target position (TARPOS), and the velocity, acceleration and deceleration for the calculation of the path from the actual axis position to the new target position. With the Program submode the motion command is provided by the program interpreter out of a motion program. One or several motion programs are stored

by motion records in a device specific manner in the program storage. Controlling of the program interpreter is done by the dedicated bits of STW1 and the signal SATZANW out of the DO IO Data.

The start of a motion program or the change to a new program while a program is still running, is done by selecting the first motion record of the new program via SATZANW (while SATZANW bit 15 = 0) and a positive edge of STW1 bit 6. The motion program is then executed by the program interpreter motion record for motion record as long as there is no stop or terminate condition in a motion record and the program is not terminated by STW1 Bit 4 = 0 (reject traversing task). Also the motion of the axis may be stopped intermediately by STW1 bit 5 = 0 (intermediate stop).

Related Objects

Index (hex)	Sub	Pn No.	Name	Access	PDO Mapping	Default value	Units	Type
6040h	0	B11	Controlword 1(STW1)	RW	RPZD	0	-	UINT
6041h	0	B12	Statusword 1 (ZSW1)	RO	TPZD	-	-	UINT
2503h	0	BB0	Controlword 2 (STW2)	RW	RPZD	0	-	UINT
2504h	0	BB1	Statusword 2 (ZSW2)	RO	TPZD	-	-	UINT
2532h	0	BD0	Traversing Block Selection (SATZANW)	RW	RPZD	0	-	UINT
2610h	-		Traversing Block Task Mode	-	-	-	-	-
	0 to 63	-	Task Mode Value	RW	No	0	-	UDINT
2611h	-		Traversing Block Target Position	-	-	-	-	-
	0 to 63	-	Target Position Value	RW	No	0	Pos. units	UDINT
2612h	-		Traversing Block Profile Velocity	-	-	-	-	-
	0 to 63	-	Profile Velocity Value	RW	No	0	Vel. units	UDINT
2613h	-		Traversing Block Profile Acceleration	-	-	-	-	-
	0 to 63	-	Profile Acceleration Value	RW	No	0	Acc. units	UDINT
2614h	-		Traversing Block Profile Deceleration	-	-	-	-	-
	0 to 63	-	Profile Deceleration Value	RW	No	0	Acc. units	UDINT
607Dh	-		Software Position Limit	-	-	-	-	-
	0	B48	Min. Position Limit	RW	No	80000000h	Pos. units	DINT
	1	B4A	Max. Position Limit	RW	No	7FFFFFFFh	Pos. units	DINT
607Fh	0	B4C	Max. Profile Velocity	RW	No	Max. motor speed	Vel. units	UDINT
6077h	0	B3E	Torque Actual Value	RO	TPZD	0	0.1 %	INT
606Ch	0	B30	Velocity Actual Value	RO	TPZD	0	Vel. units	DINT

Index (hex)	Sub	Pn No.	Name	Access	PDO Mapping	Default value	Units	Type
6063h	0	B22	Position Actual Internal Value	RO	TPZD	-	Inc	DINT
6064h	0	B24	Position Actual Value	RO	TPZD	-	Pos. units	DINT
6062h	0	B20	Position Demand Value	RO	TPZD	0	Pos. units	DINT
6085h	0	B54	Quick Stop Deceleration	RW	RPZD	Max. motor acceleration	Acc. units	UDINT
60C5h	0	B7C	Max. Acceleration	RW	No	Max. motor acceleration	Acc. units	UDINT
60C6h	0	B7E	Max. Deceleration	RW	No	Max. motor acceleration	Acc. units	UDINT
605Ah	0	B13	Quick Stop Option Code	RW	No	2 (Slow down on quick stop ramp)	-	INT
605Dh	0	B16	Halt Option Code	RW	No	3 (Slow down on Max. Deceleration (60C6h))	-	INT
606Bh	0	B2E	Velocity Demand Value	RO	TPZD	0	Vel. units	DINT
6067h	0	B2A	Position Window	RW	No	0	Pos. units	UINT
6068h	0	B2C	Position Window Time	RW	No	0	ms	UINT
6065h	0	B26	Following Error Window	RW	No	0	Pos. units	UINT
6066h	0	B28	Following Window Timeout	RW	No	0	ms	
60F4h	0	B84	Following Error Actual Value	RO	TPZD	0	Pos. units	DINT
60FCh	0	B86	Position Demand Internal Value	RO	TPZD	0	Inc	DINT
2400h*	0	BA0	Position Range Limit Designation	RW	No	0	-	UINT
2401h	0	BA2	Target Position in Range	RO	TPZD	0	Pos. units	DINT
2402h	0	BA4	Actual Position in Range	RO	TPZD	0	Pos. units	DINT
607Bh*	-		Position Range Limit	-	-	-	-	-
	0	B42	Min. Position Range Limit	RW	No	80000000h	Pos. units	DINT
	1	B44	Max. Position Range Limit	RW	No	7FFFFFFFh	Pos. units	DINT

14.3.4 Modulo Positioning

In motion control, there are two types of positioning that can be used for linear or rotary axes:

- relative positioning

Each position is based on a previous position (regardless of the actual position of the axis).

- absolute positioning

Each position is referenced to a reference or zero point.

Absolute positioning with multiturn encoders is generally used for axes with very long strokes or for axes with "endless" positioning, such as rotary tables or conveyor belts. However, if the application exceeds the maximum number of encoder revolutions, there is also a risk of a significant positioning error for the axis with multiturn encoders.

This is where modulo positioning comes into its own. The term "modulo" is borrowed from mathematics:

The modulo finds the rest after dividing two numbers. A simple example: (9 mod 4) is equal to 1, because if 9 is divided by 4, the remainder is 1.

Modulo positioning is an endless positioning in a circle and is used in applications where the motor position must be counted cyclically. The motor position is calculated with a complete mechanical rotation of the load. Depending on the application, the following modulo motion types are possible, which are defined in object Position Range Limit Designation (2400h) → [Chap. 15.7 'PROFIdrive Position Mode' ...page 523](#):

- optimized (shortest way)
- Rotation only in negative direction
- Rotation only in positive direction

Limit values (607Bh) → [Chap. 15.7 'PROFIdrive Position Mode' ...page 523](#) can be used to define the positions at which the position overflow occurs. If the maximum number of encoder rotations is exceeded, an overflow occurs and the encoder starts counting again from zero (depending on whether "0...360" or "-1800...1800" has been defined). Modulo positioning stores this overflow and ensures that no position information is lost.

Modulo positioning is possible regardless of the axis type, i.e. it can be used for both linear and rotary axes. A modulo axis has a consecutive absolute position in the range of $\pm\infty$. The modulo position of the axis is merely additional information about the absolute axis position. Modulo positioning represents the desired target position in a different way than absolute positioning (where the user clearly defines the target).

Example

Within a system, a rotary axis performs an operation. The starting position for each operation is 90° and with each cycle the axis must be positioned 360° in the positive direction.

The position of the axis is reset to the initial value once the modulo length has been exceeded. For a rotary axis with a modulo length of 0° to 360°, the axis position starts at zero again when 359° is exceeded, i.e. position 0°=360°.

Rotary Applications (e.g. Rotary Table)

Rotary Applications may e.g. be performed by Modulo Positioning functions:

- Shortest route (2400h|00 = 1)
- Always positive direction (2400h|00 = 2)
- Always negative direction (2400h|00 = 3)

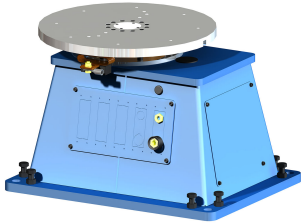


Fig. 365: R-250 1-station positioner with a vertical rotary axis

Configuration example

- Position Range: 1 Revolution
- User Unit Configuration: 0.1 deg
- 1. Disable Software Position Limits
 - 607Dh|00 Software Position Limit – Min: 8000 0000h
 - 607Dh|01 Software Position Limit – Max: 7FFF FFFFh
- 2. Enable Position Range Limits
 - 607Bh|00 Position Range Limit – Min: 0
 - 607Bh|01 Position Range Limit – Max: 3600
- 3. Enable Absolute Target Command In Positioning In Range Mode Execution
 - 2538h|00 MDI_MOD - 1 (Absolute Target Command)

Value range of corresponding target / actual values

- Target Position (607Ah): 8000 0000h to 0 to 7FFF FFFFh
- Position Actual Value (6064h): 8000 0000h to 0 to 7FFF FFFFh
- Target Position in Range (2401h): 0 to 3599
- Actual Position in Range (2402h): 0 to 3599

Linear Applications (e.g. Conveyor Belts)

Linear Applications where movement is typically in one direction only may e.g. be performed by Modulo Positioning functions:

- Always positive direction (2400h|00 = 2)
- Always negative direction (2400h|00 = 3)

Configuration example

- Conveyor belt: 1 mm per motor revolution
- Position Range: endless (e.g. step 100 mm)
- User Unit Configuration: 0.1 mm
- 1. Disable Software Position Limits
 - 607Dh|00 Software Position Limit – Min 8000 0000h
 - 607Dh|01 Software Position Limit – Max 7FFF FFFFh
- 2. Enable Position Range Limits
 - 607Bh|00 Position Range Limit – Min 0
 - 607Bh|01 Position Range Limit – Max 1000
- 3. Enable Offset Target Command In Positioning In Range Mode Execution
 - 2538h|00 MDI_MOD - 0 (Offset Target Command)

Value range of corresponding target / actual values

- Target Position (607Ah): 8000 0000h to 0 to 7FFF FFFFh
- Position Actual Value (6064h): 8000 0000h to 0 to 7FFF FFFFh
- Target Position in Range (2401h): 0 to 999
- Actual Position in Range (2402h): 0 to 999

14.4 Homing Function

The following figure shows the defined input objects as well as the output objects. The user may specify the speeds, acceleration and the method of homing. There is a further object home offset, which allows the user to displace zero in the user's coordinate system from the home position.

Homing Function

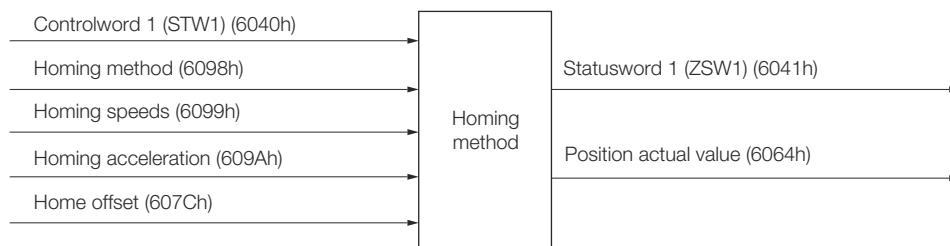


Fig. 366: Relationship between the input objects and the output objects in the Homing Mode

Related Objects

Index (hex)	Sub	Pn No.	Name	Access	PDO Mapping	Default value	Units	Type
6040h	0	B11	Controlword 1(STW1)	RW	RPZD	0	-	UINT
6041h	0	B12	Statusword 1 (ZSW1)	RO	TPZD	0	-	UINT
607Ch	0	B46	Home Offset	RW	No	0	Pos. units	DINT
6098h	0	B58	Homing Method	RW	RPZD	0	-	SINT
6099h	-		Homing Speeds	-	-	-	-	-
	0	B5A	Speed during search for switch	RW	No	0	Vel. units	UDINT
	1	B5C	Speed during search for zero	RW	No	0	Vel. units	UDINT
609Ah	0	B5E	Homing Acceleration	RW	No	0	Acc. units	UDINT
6064h	0	B24	Position Actual Value	RO	TPZD	-	Pos. units	DINT

Homing Method (6098h)

In the object dictionary you will find the data description of the homing method:

→ [Chap. 15.8 'Homing Function' ...page 531](#)

14.5 PROFIdrive Velocity Mode

In the PROFIdrive velocity mode, the speed is output in accordance with the profile acceleration and profile deceleration, until it reaches the target velocity.

The following figure shows the block diagram of the PROFIdrive velocity mode.

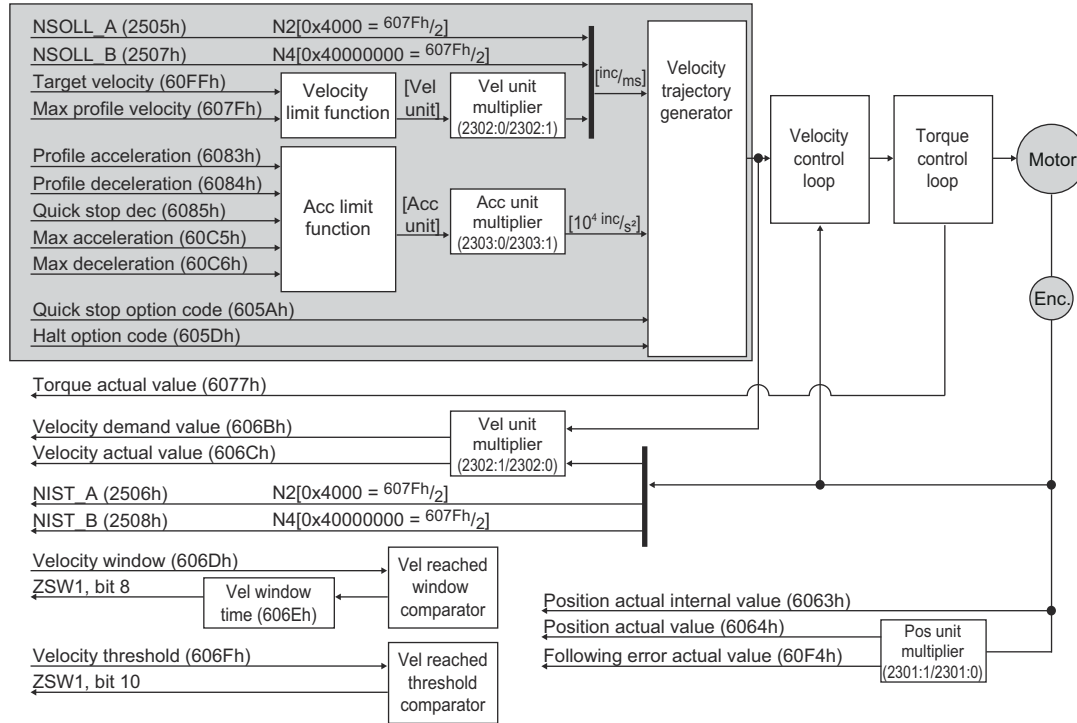


Fig. 367: PROFIdrive Velocity Mode

Related Objects

Index (hex)	Sub	Pn No.	Name	Access	PDO Mapping	Default value	Units	Type
6040h	0	B11	Controlword 1(STW1)	RW	RPZD	0	-	UINT
6041h	0	B12	Statusword 1 (ZSW1)	RO	TPZD	0	-	UINT
2503h	0	BB0	Controlword 2 (STW2)	RW	RPZD	0	-	UINT
2504h	0	BB1	Statusword 2 (ZSW2)	RO	TPZD	-	-	UINT
2505h	0	BB2	Speed Setpoint A	RW	RPZD	0	N2	INT
2507h	0	BB4	Speed Actual Value A	RO	TPZD	0	N2	INT
60FFh	0	B8E	Target Velocity	RW	RPZD	0	Vel. units	DINT
2506h	0	BB3	Speed Setpoint B	RW	RPZD	0	N4	DINT
2508h	0	BB6	Speed Actual Value B	RO	TPZD	0	N4	DINT
606Ch	0	B30	Velocity Actual Value	RO	TPZD	0	Vel. units	DINT
6077h	0	B3E	Torque Actual Value	RO	TPZD	0	0.1 %	INT
6063h	0	B22	Position Actual Internal Value	RO	TPZD	-	Inc	DINT
6064h	0	B24	Position Actual Value	RO	TPZD	-	Pos. units	DINT
607Fh	0	B4C	Max. Profile Velocity	RW	No	Max. motor speed	Vel. units	UDINT

PROFIdrive Velocity Mode

Index (hex)	Sub	Pn No.	Name	Access	PDO Mapping	Default value	Units	Type
6083h	0	B50	Profile Acceleration	RW	RPZD	0	Acc. units	UDINT
6084h	0	B52	Profile Deceleration	RW	RPZD	0	Acc. units	UDINT
6085h	0	B54	Quick Stop Deceleration	RW	RPZD	Max. motor acceleration	Acc. units	UDINT
60C5h	0	B7C	Max. Acceleration	RW	No	Max. motor acceleration	Acc. units	UDINT
60C6h	0	B7E	Max. Deceleration	RW	No	Max. motor acceleration	Acc. units	UDINT
605Ah	0	B13	Quick Stop Option Code	RW	No	2 (Slow down on quick stop ramp)	-	INT
605Dh	0	B16	Halt Option Code	RW	No	3 (Slow down on Max. Deceleration (60C6h))	-	INT
606Bh	0	B2E	Velocity Demand Value	RO	TPZD	0	Vel. units	DINT
606Dh	0	B32	Velocity Window	RW	No	0	Vel. units	UINT
606Eh	0	B34	Velocity Window Time	RW	No	0	ms	UINT
606Fh	0	B35	Velocity Threshold	RW	No	0	Vel. units	UINT
60F4h	0	B84	Following Error Actual Value	RO	TPZD	0	Pos. units	DINT

14.6 Profile Torque Mode

In the Profile Torque Mode, the torque is output up to the *Target Torque* according to the *Torque Slope* setting.

The following figure shows the block diagram of the Profile Torque Mode.

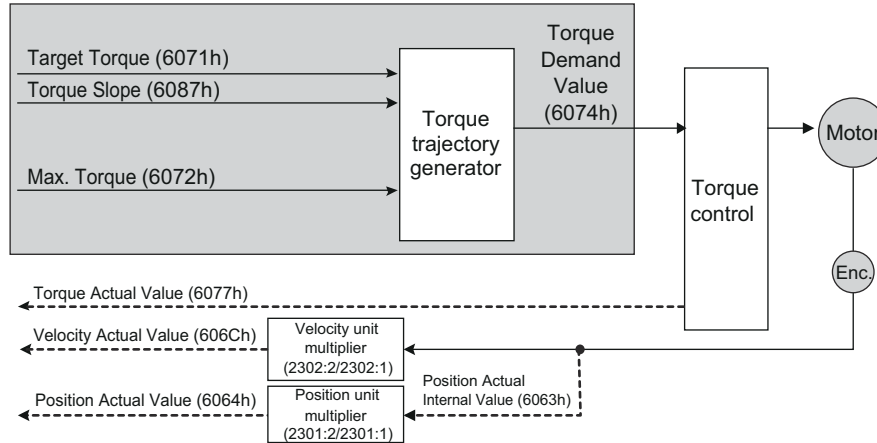


Fig. 368: Profile Torque Mode

Related Objects

Index (hex)	Sub	Pn No.	Name	Access	PDO Mapping	Default value	Units	Type
6063h	0	B22	Position Actual Internal Value	RO	TPZD	-	Inc	DINT
6064h	0	B24	Position Actual Value	RO	TPZD	-	Pos. units	DINT
606Ch	0	B30	Velocity Actual Value	RO	TPZD	-	Inc	DINT
6071h	0	B36	Target Torque	RW	RPZD	0	0.1%*	INT
6072h	0	B38	Max. Torque	RW	No	Max. motor torque	0.1%*	UINT
6074h	0	B3A	Torque Demand Value	RO	TPZD	0	0.1%*	INT
6077h	0	B3E	Torque Actual Value	RO	TPZD	0	0.1%*	INT
6087h	0	B56	Torque Slope	RW	RPZD	0	0.1%/s*	UDINT

* The rated motor torque is 100%.

14.7 Torque Limits

The following figure shows the block diagram for the torque limits. The torque is limited by the lowest limit value.

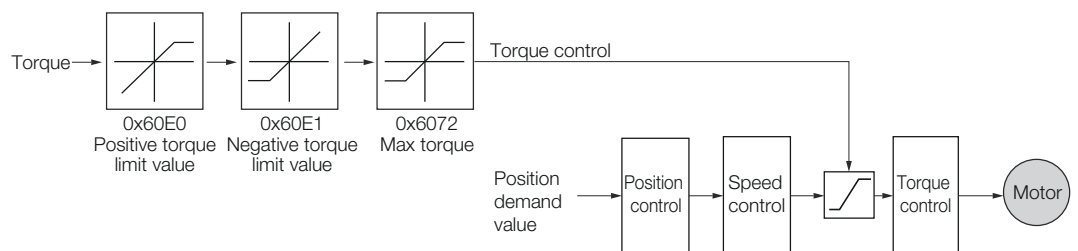


Fig. 369: Torque Limits

Digital Inputs and Outputs

Related Objects

Index (hex)	Sub	Pn No.	Name	Access	PDO Mapping	Default value	Units	Type
6072h	0	B38	Max. Torque	RW	No	Max. motor torque	0.1%*	UINT
60E0h	0	B80	Positive Torque Limit Value	RW	RPZD	Max. motor torque	0.1%*	UINT
60E1h	0	B82	Negative Torque Limit Value	RW	RPZD	Max. motor torque	0.1%*	UINT

* The rated motor torque is 100%.

14.8 Digital Inputs and Outputs

The *Digital Inputs* and *Digital Outputs* are used to control the I/O signals of the CN1 connector on the SERVOPACK.

Related Objects

Index (hex)	Sub	Pn No.	Name	Access	PDO Mapping	Default value	Units	Type
2521h	0	BC0	Digital Inputs	RO	TPZD	-	-	UINT
2522h	0	BC1	Digital Outputs	RW	RPZD	0	-	UINT

14.9 Touch Probe Function

The SERVOPACK provides two fast touch probe inputs. The Touch Probe function allows the user to record the actual position of the connected motor at the time of a digital trigger event (e.g. signal edge at the touch probe input) and makes this value *immediately* available to the controller. The actual position is then further processed by the controller, depending on the control system.

Sample application: Feed-to-length

A feed-to-length application is one where a specific amount of material is to be fed a known distance and stopped, then followed by another process. There are no stipulations on the size and type of material, and no limitations on the following process once the material has been fed.

Materials range from fine gauge wire, to slabs of steel, to sheets of plastic. Post-feed processes include cutting, welding, scoring, and stamping, to name a few. Common methods of feeding material in a feed-to-length application include the use of conveyors or pinch rolls. The walking beam approach is also used, while another approach uses a gripper to pull the product to the desired length.

Applications which can benefit from the Touch Probe function are cut-to-length, vertical form fill and seal machines that do not require camming, paper cutting, wire cutting, stamping, and any other high speed application where moves are based on high speed registration.

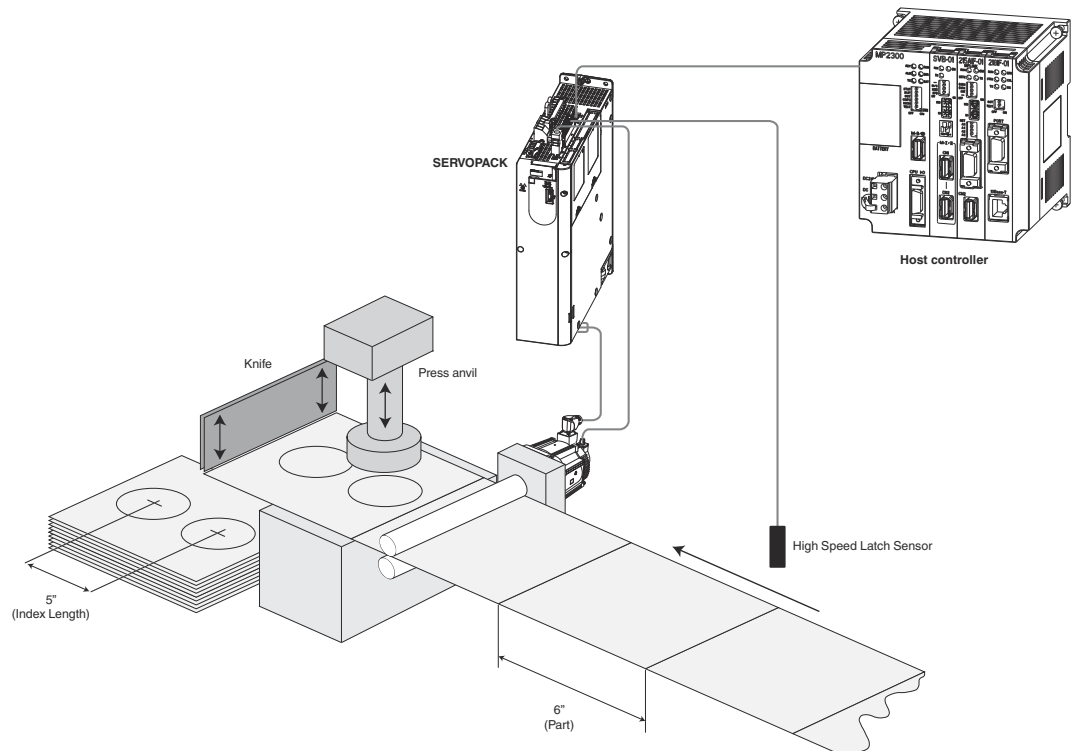


Fig. 370: Feed-to-length sample application - Stamping

You can latch the feedback position with the following trigger events.

- Trigger with touch probe 1 input (Probe 1 Latch Input (/EXT1) signal)
- Trigger with touch probe 2 input (Probe 2 Latch Input (/EXT2) signal)
- Trigger with encoder zero signal (phase C)

The following two touch probe latches can be used at the same time.

- Touch Probe 1 Latch
 - Latch control object: 60B8h (bits 0 to 7)
 - Latch status object: 60B9h (bits 0 to 7)
 - The latched position is always stored in *Touch Probe 1 Position Value* (60BAh).
 - Trigger signal: Encoder zero signal or /EXT1 signal

Touch Probe Function

- Touch Probe 2 Latch
 - Latch control object: 60B8h (bits 8 to 15)
 - Latch status object: 60B9h (bits 8 to 15)
 - The latched position is always stored in *Touch Probe 2 Position Value* (60BCh).
 - Trigger signal: /EXT2 signal

You can change the connector pin assignments and the /EXT1 and /EXT2 signal logic in the Probe 1 Latch Input Signal parameter (Pn511 = □□X□) and the Probe 2 Latch Input Signal parameter (Pn511 = □X□□).



Touch probe 1 cannot be used during homing. If touch probe 1 was already active, it will be switched OFF.

Related Objects

Index (hex)	Sub	Pn No.	Name	Access	PDO Mapping	Default value	Units	Type
60B8h	0	B64	Touch Probe Function	RW	RPZD	0	-	UINT
60B9h	0	B66	Touch Probe Status	RO	TPZD	0	-	UINT
60BAh	0	B68	Touch Probe 1 Position Value	RO	TPZD	-	Pos. unit	DINT
60BCh	0	B6A	Touch Probe 2 Position Value	RO	TPZD	-	Pos. unit	DINT

Example of Execution Procedure for a Touch Probe



60B8h bit 2/10 cannot be changed after 60B8h bit 4/12 was set to 1.

Single Trigger Mode (60B8h bit 1 = 0 or bit 9 = 0)

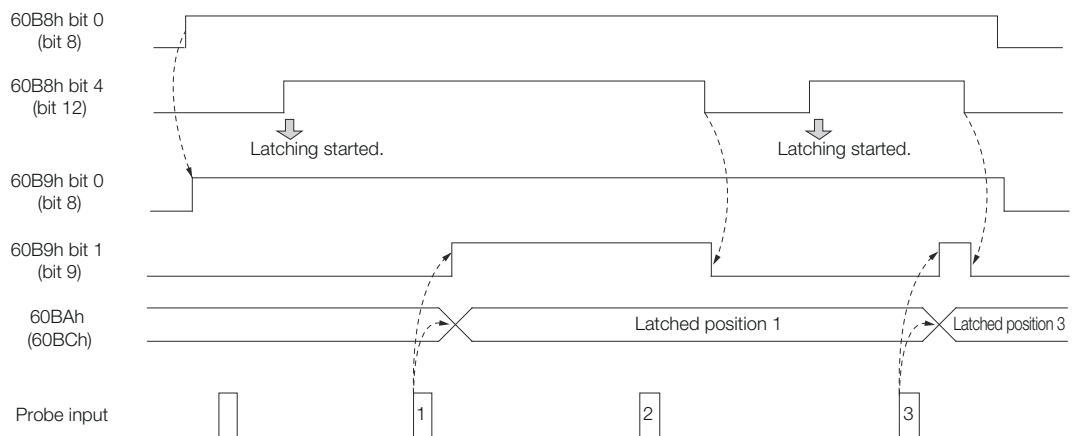


Fig. 371: Execution Procedure for a Touch Probe - Single Trigger Mode

Continuous Trigger Mode (60B8h bit 1 = 1 or bit 9 = 1)

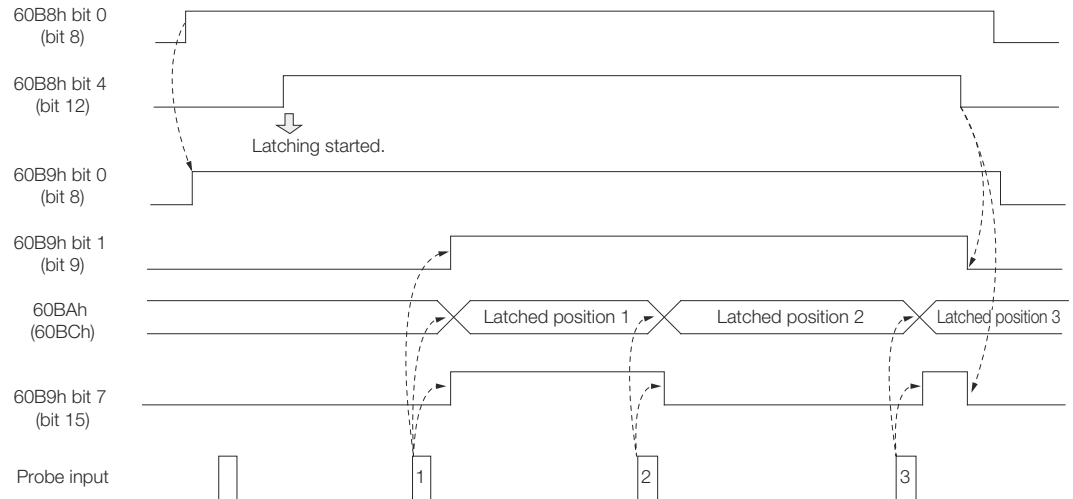


Fig. 372: Execution Procedure for a Touch Probe - Continuous Trigger Mode

14.10 Fully-closed Loop Control

The following figure shows the block diagram for the fully-closed loop control.

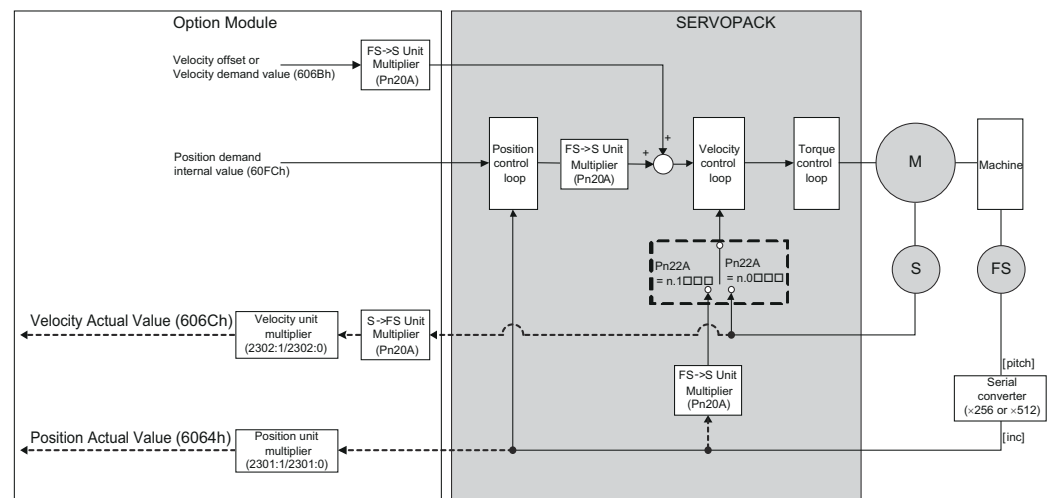


Fig. 373: Fully-closed Loop Control

Setting Parameters

The basic setting procedure for the related parameters is given in the following table.

Step	Description	Parameter Setting
1	Set the speed feedback method to use during fully-closed loop control.	Fully-closed Control Selections (Pn22A)
2	Set the motor rotation direction.	Rotation Direction Selection (Pn000 = n.□□□X) External Encoder Usage (Pn002 = n.X□□□)
3	Set the number of pitches (cycles) of the sine wave for the external encoder.	Number of External Scale Pitches (Pn20A)
4	Set the position reference unit (electronic gear).	Position User Unit (2301h)

Get/Set SERVOPACK Parameter Functionality

Step	Description	Parameter Setting
5	Set the alarm detection level for the external encoder.	Motor-Load Position Deviation Overflow Detection Level (Pn51B) Multiplier per Fully-closed Rotation (Pn52A)

14.11 Get/Set SERVOPACK Parameter Functionality

Internal SERVOPACK parameters (Pn□□□□) → [Chap. 17.2.2 'List of Parameters' ...page 623](#) can be read or written with PROFINET Communications.

Get SERVOPACK Parameter

Reading internal Servo parameter. In order to read SERVOPACK parameter do the following:

- Write parameter number to object "Get Parameter - Parameter Identify" (2100h)
- Read the value from object "Get Parameter - Parameter Value" (2101h)

Related Objects

Index (hex)	Sub	Pn No.	Name	Access	PDO Mapping	Default value	Units	Type
2100h	0		Get Parameter - Parameter Identify	RW	No	FFFFh	-	UINT
2101h	0		Get Parameter - Parameter Value	RO	No	0	-	DINT

Set SERVOPACK Parameter

Setting / Writing internal Servo parameter. In order to set Servo parameter do the following:

- Write parameter number to object "Set Parameter - Parameter Identify" (2102h)
- Write the value into object "Set Parameter - Parameter Value" (2103h)

Related Objects

Index (hex)	Sub	Pn No.	Name	Access	PDO Mapping	Default value	Units	Type
2102h	0		Set Parameter - Parameter Identify	RW	No	FFFFh	-	UINT
2103h	0		Set Parameter - Parameter Value	RW	No	0	-	DINT

15 Object Dictionary

15.1 Overview

This chapter provides tables of the objects that are supported by a PROFINET SERVOPACK. Each object is described.

15.2 Object Dictionary List

The following table lists the dictionary objects.

Functional Classification	Object Name	Index (hex)	Index (dec)	PNU (dec)	Refer to
General Objects	Drive Unit Identification			964	↔ 'Drive Unit Identification' ...page 498
	Profile Identification Number			965	↔ 'Profile Identification Number' ...page 498
	Drive Reset			972	↔ 'Drive Reset' ...page 499
	Base Mode Parameter Access Service Identification			974	↔ 'Base Mode Parameter Access Service Identification' ...page 499
	DO Identification			975	↔ 'DO Identification' ...page 500
	Load Device Parameter Set			976	↔ 'Load Device Parameter Set' ...page 500
	Transfer in Non-volatile Memory (global)			977	↔ 'Transfer in Non-volatile Memory (global)' ...page 501
	Name of Station		61000		↔ 'Name of Station' ...page 501
	IP of Station		61001		↔ 'Ip of Station' ...page 501
	MAC of Station		61002		↔ 'Mac of Station' ...page 501
	Standard Gateway of Station		61003		↔ 'Standard Gateway of Station' ...page 502
	Subnet Mask of Station		61004		↔ 'Subnet Mask of Station' ...page 502
Communication Objects	DO IO Data Configuring (Setpoint Telegram)			915	↔ 'DO IO Data Configuring (Setpoint Telegram)' ...page 503
	DO IO Data Configuring (Actual Value Telegram)			916	↔ 'DO IO Data Configuring (Actual Value Telegram)' ...page 503
	Telegram Selection			922	↔ 'Telegram Selection' ...page 503
	List of all Parameters for Signals			923	↔ 'List of All Parameters for Signals' ...page 504
	Sign-Of-Life Failures			925	↔ 'Sign-Of-Life Failures' ...page 504
	PROFIdrive Operating Mode			930	↔ 'PROFIdrive Operating Mode' ...page 505
	Fault Message Counter			944	↔ 'Fault Message Counter' ...page 505
	Fault Number			947	↔ 'Fault Number' ...page 505
	Fault Situation Counter			952	↔ 'Fault Situation Counter' ...page 505

Object Dictionary List

Functional Classification	Object Name	Index (hex)	Index (dec)	PNU (dec)	Refer to
	Number List of Defined Parameter			980 to 989	↔ <i>'Number List of Defined Parameter' ...page 506</i>
Manufacturer Specific Objects	Get Parameter - Parameter Identify	2100h			↔ <i>'Get Parameter - Parameter Identify' ...page 507</i>
	Get Parameter - Parameter Value	2101h			↔ <i>'Get Parameter - Parameter Value' ...page 507</i>
	Set Parameter - Parameter Identify	2102h			↔ <i>'Set Parameter - Parameter Identify' ...page 508</i>
	Set Parameter - Parameter Value	2103h			↔ <i>'Set Parameter - Parameter Value' ...page 508</i>
	User Parameter Configuration	2300h			↔ <i>'User Parameter Configuration' ...page 509</i>
	Position User Unit	2301h			↔ <i>'Position User Unit' ...page 509</i>
	Velocity User Unit	2302h			↔ <i>'Velocity User Unit' ...page 510</i>
	Acceleration User Unit	2303h			↔ <i>'Acceleration User Unit' ...page 510</i>
	Max. Motor Speed	2312h			↔ <i>'Max. Motor Speed' ...page 510</i>
	Max. Motor Acceleration	2313h			↔ <i>'Max. Motor Acceleration' ...page 511</i>
	Max. Motor Torque	2314h			↔ <i>'Max. Motor Torque' ...page 511</i>
Device Control	Error Code	603Fh			↔ <i>'Error Code' ...page 512</i>
	Controlword (STW1)	6040h			↔ <i>'Controlword (STW1)' ...page 512</i>
	Statusword (ZSW1)	6041h			↔ <i>'Statusword (ZSW1)' ...page 514</i>
	Quick Stop Option Code	605Ah			↔ <i>'Quick Stop Option Code' ...page 518</i>
	Halt Option Code	605Dh			↔ <i>'Halt Option Code' ...page 519</i>
	Fault Reaction Option Code	605Eh			↔ <i>'Fault Reaction Option Code' ...page 519</i>
	Modes of Operation	6060h			↔ <i>'Modes of Operation' ...page 520</i>
	Modes of Operation Display	6061h			↔ <i>'Modes of Operation Display' ...page 520</i>
	Controlword 2 (STW2)	2503h			↔ <i>'Controlword 2 (STW2)' ...page 521</i>
	Statusword 2 (ZSW2)	2504h			↔ <i>'Statusword 2 (ZSW2)' ...page 522</i>
PROFIdrive Position Mode	Position Range Limit Designation	2400h			↔ <i>'Position Range Limit Designation' ...page 523</i>
	Target Position in Range	2401h			↔ <i>'Target Position in Range' ...page 523</i>
	Actual Position in Range	2402h			↔ <i>'Actual Position in Range' ...page 523</i>
	Traversing Block Selection (SAT-ZANW)	2532h			↔ <i>'Traversing Block Selection (SAT-ZANW)' ...page 524</i>

Functional Classification	Object Name	Index (hex)	Index (dec)	PNU (dec)	Refer to
	Actual Traversing Block (AKT-SATZ)	2533h			↔ 'Actual Traversing Block (AKT-SATZ)' ...page 524
	MDI Acceleration (MDI_ACC)	2536h			↔ 'MDI Acceleration (MDI_ACC)' ...page 525
	MDI Deceleration (MDI_DEC)	2537h			↔ 'MDI Deceleration (MDI_DEC)' ...page 525
	MDI Mode (MDI_MOD)	2538h			↔ 'MDI Mode (MDI_MOD)' ...page 525
	Traversing Block Task Mode	2610h			↔ 'Traversing Block Task Mode' ...page 526
	Traversing Block Target Position	2611h			↔ 'Traversing Block Target Position' ...page 526
	Traversing Block Profile Velocity	2612h			↔ 'Traversing Block Profile Velocity' ...page 526
	Traversing Block Profile Acceleration	2613h			↔ 'Traversing Block Profile Acceleration' ...page 526
	Traversing Block Profile Deceleration	2614h			↔ 'Traversing Block Profile Deceleration' ...page 527
	Target Position (MDI_TARPOS)	607Ah			↔ 'Target Position' ...page 527
	Position Range Limit	607Bh			↔ 'Position Range Limit' ...page 527
	Software Position Limit	607Dh			↔ 'Software Position Limit' ...page 528
	Max. Profile Velocity	607Fh			↔ 'Max. Profile Velocity' ...page 528
	Profile Velocity (MDI_VELOCITY)	6081h			↔ 'Profile Velocity' ...page 528
	Profile Acceleration	6083h			↔ 'Profile Acceleration' ...page 529
	Profile Deceleration	6084h			↔ 'Profile Deceleration' ...page 529
	Quick Stop Deceleration	6085h			↔ 'Quick Stop Deceleration' ...page 529
	Max. Acceleration	60C5h			↔ 'Max. Acceleration' ...page 530
	Max. Deceleration	60C6h			↔ 'Max. Deceleration' ...page 530
Homing Function	Home Offset	607Ch			↔ 'Home Offset' ...page 531
	Homing Method	6098h			↔ 'Homing Method' ...page 531
	Homing Speeds	6099h			↔ 'Homing Speeds' ...page 533
	Homing Acceleration	609Ah			↔ 'Homing Acceleration' ...page 533
Position Control Function	Position Demand Value	6062h			↔ 'Position Demand Value' ...page 534
	Position Actual Internal Value	6063h			↔ 'Position Actual Internal Value' ...page 534
	Position Actual Value	6064h			↔ 'Position Actual Value' ...page 534
	Following Error Window	6065h			↔ 'Following Error Window' ...page 534

Object Dictionary List

Functional Classification	Object Name	Index (hex)	Index (dec)	PNU (dec)	Refer to
	Following Error Time Out	6066h			↔ 'Following Error Time Out' ...page 534
	Position Window	6067h			↔ 'Position Window' ...page 534
	Position Window Time	6068h			↔ 'Position Window Time' ...page 535
	Following Error Actual Value	60F4h			↔ 'Following Error Actual Value' ...page 535
	Position Demand Internal Value	60FCh			↔ 'Position Demand Internal Value' ...page 535
PROFIdrive Velocity Mode	Speed Setpoint A (NSOLL_A)	2505h			↔ 'Speed Setpoint A (NSOLL_A)' ...page 536
	Speed Actual Value A (NIST_A)	2506h			↔ 'Speed Actual Value A (NIST_A)' ...page 536
	Speed Setpoint B (NSOLL_B)	2507h			↔ 'Speed Setpoint B (NSOLL_B)' ...page 536
	Speed Actual Value B (NIST_B)	2508h			↔ 'Speed Actual Value B (NIST_B)' ...page 536
	Velocity Demand Value	606Bh			↔ 'Velocity Demand Value' ...page 537
	Velocity Actual Value	606Ch			↔ 'Velocity Actual Value' ...page 537
	Velocity Window	606Dh			↔ 'Velocity Window' ...page 537
	Velocity Window Time	606Eh			↔ 'Velocity Window Time' ...page 537
	Velocity Threshold	606Fh			↔ 'Velocity Threshold' ...page 537
	Target Velocity	60FFh			↔ 'Target Velocity' ...page 538
Profile Torque Mode	Target Torque	6071h			↔ 'Target Torque' ...page 539
	Max. Torque	6072h			↔ 'Max. Torque' ...page 539
	Torque Demand Value	6074h			↔ 'Torque Demand Value' ...page 539
	Torque Actual Value	6077h			↔ 'Torque Actual Value' ...page 539
	Torque Slope	6087h			↔ 'Torque Slope' ...page 540
	Positive Torque Limit Value	60E0h			↔ 'Positive Torque Limit Value' ...page 540
	Negative Torque Limit Value	60E1h			↔ 'Negative Torque Limit Value' ...page 540
Touch Probe Function	Touch Probe Function	60B8h			↔ Chap. 15.12 'Touch Probe Function' ...page 541
	Touch Probe Status	60B9h			↔ 'Touch Probe Status' ...page 542
	Touch Probe 1 Position Value	60BAh			↔ 'Touch Probe 1 Position Value' ...page 542
	Touch Probe 2 Position Value	60BCh			↔ 'Touch Probe 2 Position Value' ...page 543

Functional Classification	Object Name	Index (hex)	Index (dec)	PNU (dec)	Refer to
Digital Inputs/ Outputs	Digital Inputs	2521h			→ <i>'Digital Inputs' ...page 544</i>
	Digital Outputs	2522h			→ <i>'Digital Outputs' ...page 545</i>

15.3 General Objects

Drive Unit Identification

All data for Drive Unit identification is included under this parameter, and is made available to the identify service.

PNU (dec)	Name	Data Type	Access	PDO Mapping	Value	Saving to EEPROM
964	Drive Unit Identification	Array UINT[5]	RO	No	-	No

Data Description

Sub-index	Contents	Value	Comments
0	Manufacturer	0111h	YASKAWA Vendor ID
1	Drive Unit type	0251h [Sigma-7 200 V] 0252h [Sigma-7 400 V]	In this area, the type (ID) of the SERVOPACK is stored.
2	Version (Software)		xxyy (decimal) 0201 ⇒ Version 2.1
3	Firmware date (year)		yyyy (decimal) 2019 ⇒ year 2019
4	Firmware date (day/month)		ddmm (decimal) 1501 ⇒ 15th of January
5	Number of Drive Objects (DO)	0001h	-

Profile Identification Number

Displays the PROFIdrive profile number and profile version.

PNU (dec)	Name	Data Type	Access	PDO Mapping	Value	Saving to EEPROM
965	Profile Identification Number	OS[2]	RO	No	0329h	No

Data Description

Byte	Contents	Value	Comments
1	Profile number	03h	PROFIdrive profile
2	Profile version	29h	Version 4.1



When the parameter is read via PROFIdrive, the Octet String 2 data type applies.

Drive Reset

Reset of whole drive unit.

PNU (dec)	Name	Data Type	Access	PDO Mapping	Value	Saving to EEPROM
972	Drive Reset	UINT	RW	No	0 to 1 (default: 0)	No

Data Description

Parameter value	Meaning
0	Initial status (or status after a reset)
1	Power-on reset (initiation)

The reset is possible using the optional parameter PNU 972 in the following manner: The reset is initiated by write accessing PNU 972 = 1.



The write access to PNU 972 (with value 1) results in a drive reset and therefore from the perspective of the Controller in a Drive Unit failure. It cannot be guaranteed that the positive acknowledgement is still sent in time from the Drive Unit or received from the Controller.

Base Mode Parameter Access Service Identification

Description of the features of the Base Mode Parameter Access service.

PNU (dec)	Name	Data Type	Access	PDO Mapping	Value	Saving to EEPROM
974	Base Mode Parameter Access Service Identification	Array UINT	RO	No	-	No

Data Description

Sub-index	Contents	Value	Comments
0	Max. block length	240	Maximum block length in byte, for the parameter request and response block, which is supported by the parameter manager
1	Max. number of parameter requests per multi-parameter request	39	
2	Max. latency per request (n x 10 ms)	0	<p>Maximum latency time for the processing of a parameter request (time between request and response without time consumed on the communication line for a worst case scenario).</p> <p>The latency time is calculated by multiplication of the value in this subindex with 10 ms.</p> <p>A value = 0 indicates that there is no specification available. Note that the maximum latency time per request also includes additional time consumed for a multi-parameter request (of max. number of parameters).</p>

General Objects

DO Identification

All data for DO identification is included under this parameter, and is made available to the identify service.

PNU (dec)	Name	Data Type	Access	PDO Mapping	Value	Saving to EEPROM
975	DO Identification	Array UINT	RO	No	-	No

Data Description

Sub-index	Contents	Value	Comments
0	Manufacturer	0111h	YASKAWA Vendor ID
1	DO type	0000h	
2	Version (Software)		xxyy (decimal) 0201 --> Version 2.1
3	Firmware date (year)		yyyy (decimal) 2019 --> Year 2019
4	Firmware date (day/month)		ddmm (decimal) 1501 --> 15th of January
5	PROFIdrive DO type class (structure)	0001h	Axis
6	PROFIdrive DO sub class 1	0005h	Application Classes 1 and 3 supported
7	Drive object ID (DO-ID)	0001h	

Load Device Parameter Set

Set the whole DU parameter set to default values.

PNU (dec)	Name	Data Type	Access	PDO Mapping	Value	Saving to EEPROM
976	Load Device Parameter Set	UINT	RW	No	0 to 1 (default: 0)	No

Data Description

Parameter value	Meaning
0	Inactive
1	Resetting the communication parameters (2□□□h and application parameters (6□□□h) to factory settings. After saving a data set parameter 976 is reset to 0.

PNU 976 is used to reset the communication parameters (2□□□h) and application parameters (6□□□h) to the factory setting.



The default values are set as valid after the SGM7S SERVOPACK has been reset or power cycled.

Transfer in Non-volatile Memory (global)

Store the whole DU parameter set to a non volatile memory.

PNU (dec)	Name	Data Type	Access	PDO Mapping	Value	Saving to EEPROM
977	Transfer in Non-volatile Memory (global)	UINT	RW	No	0 to 1 (default: 0)	No

Data Description

Value	Comments
0	Inactive
1	Actual communication parameters (2□□□h and application parameters (6□□□h) of the device are saved in non-volatile memory. After saving a data set, parameter 977 is reset to 0.

All communication parameters (2□□□h and application parameters (6□□□h), i.e. parameters of all axes and the global parameters are saved with this parameter.

Name of Station

This read only parameter contains the Name of Station for the PROFINET IO Network Interface, which is related to this Drive Unit. This is an additional service parallel to the standard PROFINET IO mechanism, which makes the Name of Station also accessible via PROFIdrive Parameter Access.

PNU (dec)	Name	Data Type	Access	PDO Mapping	Value	Saving to EEPROM
61000	Name of Station	OS[240]	RO	No	-	Yes

Ip of Station

This read only parameter contains the IP Address of the Station for the PROFINET IO Network Interface, which is related to this Drive Unit. This is an additional service parallel to the standard PROFINET IO mechanism, which makes the IP Address of Station also accessible via PROFIdrive Parameter Access.

PNU (dec)	Name	Data Type	Access	PDO Mapping	Value	Saving to EEPROM
61001	Ip of Station	OS[4]	RO	No	-	Yes

Mac of Station

This read only parameter contains the MAC Address of the Station for the PROFINET IO Network Interface, which is related to this Drive Unit. This is an additional service parallel to the standard PROFINET IO mechanism, which makes the MAC Address of Station also accessible via PROFIdrive Parameter Access.

PNU (dec)	Name	Data Type	Access	PDO Mapping	Value	Saving to EEPROM
61002	Mac of Station	OS[6]	RO	No	-	Yes

General Objects

Standard Gateway of Station

This read only parameter contains the Next Default Gateway for the Station for the PROFINET IO Network Interface, which is related to this Drive Unit. This is an additional service parallel to the standard PROFINET IO mechanism, which makes the Next Default Gateway of the Station also accessible via PROFIdrive Parameter Access.

PNU (dec)	Name	Data Type	Access	PDO Mapping	Value	Saving to EEPROM
61003	Standard Gateway of Station	OS[4]	RO	No	-	Yes

Subnet Mask of Station

This read only parameter contains the Subnet Mask of the Station for the PROFINET IO Network Interface, which is related to this Drive Unit. This is an additional service parallel to the standard PROFINET IO mechanism, which makes the Subnet Mask of the PROFINET interface also accessible via PROFIdrive Parameter Access.

PNU (dec)	Name	Data Type	Access	PDO Mapping	Value	Saving to EEPROM
61004	Subnet Mask of Station	OS[4]	RO	No	-	Yes

15.4 Communication Objects

DO IO Data Configuring (Setpoint Telegram)

The number n of array elements corresponds to the number of DO IO Data in the set point telegram.

PNU (dec)	Name	Data Type	Access	PDO Mapping	Value	Saving to EEPROM
915	DO IO Data Configuring (Setpoint Telegram)	Array UINT[16]	RW	No	UINT (default: 0)	Yes

DO IO Data Configuring (Actual Value Telegram)

The number n of the array elements corresponds to the number of DO IO Data in the actual value telegram.

PNU (dec)	Name	Data Type	Access	PDO Mapping	Value	Saving to EEPROM
916	DO IO Data Configuring (Actual Value Telegram)	Array UINT[16]	RW	No	UINT (default: 0)	Yes

Telegram Selection

Sets the send and receive telegram.

PNU (dec)	Name	Data Type	Access	PDO Mapping	Value	Saving to EEPROM
922	Telegram Selection	UINT	RW	No	0 to 999 (default: 1)	Yes

The IO Data telegram can be determined by selecting pre-defined standard or manufacturer specific telegram number from the following table.

Data Description

Value	Comments
0	Telegram may be freely configured (P915[x], P916[x])
1	Standard telegram 1: Speed mode
2	Standard telegram 2: Speed mode
7	Standard telegram 7: positioning interface (program submode)
9	Standard telegram 9: positioning interface (program plus MDI submode)
100	YASKAWA telegram 100
999	Free configurable telegram 999

If PNU 922 is changed to 0, the previous setting of P915[x], P916[x] is kept and the signals configuration is allowed by setting P915[x], P916[x] with the desired signals. Note that the previous setting of P915[x], P916[x] is "0" by default. Activating the telegram and validity check is done by setting PNU 922 = 999.

Communication Objects

List of All Parameters for Signals

Using parameter 923 [Signal number], an assignment is made between the signal numbers and the associated manufacturer-specific parameter numbers. The array index is the number of the signal. Array indices 1 to 99 consist of the standard signals defined in the profile array indices 100 to 65535 containing the device-specific signals if they are defined.

PNU (dec)	Name	Data Type	Access	PDO Mapping	Value	Saving to EEPROM
923	List of All Parameters for Signals	Array UINT[n]	RO	No	↪ <i>Chap. 13.7 'IO Data Signals' ...page 470</i>	No

Data Description

Value	Comments
923[y]	<p>List of all the parameters for signals (y = signal number)</p> <p>The following is valid for parameter 923[y]:</p> <ul style="list-style-type: none"> ■ There is an entry for all standard signals which the device supports and for the device-specific signals. ■ Standard signals which are not supported are identified with the entry 0. ■ Gaps between device-specific signal numbers are filled with zeros.

Sign-Of-Life Failures

Sets the number of tolerated consecutive sign-of-life errors of the clock-cycle synchronous master.

PNU (dec)	Name	Data Type	Access	PDO Mapping	Value	Saving to EEPROM
925	Sign-Of-Life Failures	UINT	RW	No	UINT (default: 1)	Yes



Optionally with value FFFFh the life sign monitoring may be switched off (for test purpose).

PROFIdrive Operating Mode This is used to designate the operating mode. Depending on the type of device this parameter is preset by the manufacturer. All numerical values with bit 15 (MSB) = 1 designate manufacturer-specific modes.

PNU (dec)	Name	Data Type	Access	PDO Mapping	Value	Saving to EEPROM
930	PROFIdrive Operating Mode	UINT	RO	No	UINT (default: 8000h)	No

PROFIdrive Mode presentation of actual mode (index 6061h)

Data Description

Value	Data description	Explanation
0001h	PROFIdrive Profile Velocity mode	
0002h	PROFIdrive Profile Position mode	
80FFh	Pole detection mode	
8000h	No mode change/no mode assigned	No movement. Usually after power on.
8004h	Profile Torque Mode	

Fault Message Counter The fault message counter is incremented each time that the fault buffer changes. This means, that it may be guaranteed that the fault buffer may be consistently read-out. Without this parameter, it is not guaranteed that the fault buffer had not changed while reading-out.

PNU (dec)	Name	Data Type	Access	PDO Mapping	Value	Saving to EEPROM
944	Fault Message Counter	UINT	RO	No	UINT (default: 0)	No

Fault Number The fault number is identical to the fault code.

PNU (dec)	Name	Data Type	Access	PDO Mapping	Value	Saving to EEPROM
947	Fault Number	UINT	RO	No	-	No

Data Description

Refer to fault code.

Fault Situation Counter Sum of all of the fault situations since the last reset. If this parameter is set to 0 (write), the complete fault buffer is deleted.

PNU (dec)	Name	Data Type	Access	PDO Mapping	Value	Saving to EEPROM
952	Fault Situation Counter	UINT	RO	No	UINT (default: 0)	No

Communication Objects

Number List of Defined Parameter Displays the parameters that exist for this drive.

PNU (dec)	Name	Data Type	Access	PDO Mapping	Value	Saving to EEPROM
980 to 989	Number List of Defined Parameter	UINT[n]	RO	No	-	No

Data Description

The number n of array elements is manufacturer-specific. All parameter numbers defined in a device are saved in parameters under the subindices (manufacturer-specific and profile parameters).

The arrays shall be assigned in increasing sequence and consecutively. If a subindex contains zero, the end of the list of defined parameters has been reached. If a subindex contains the parameter number of the next list parameter, then the list is continued there.

Therefore the PNU 980 to 989 are omitted from the Number list of defined parameter. The number list of defined parameter shall be implemented for every DO. Parameters of the number list which are empty may not be implemented.

15.5 Manufacturer Specific Objects

Get Parameter - Parameter Identify The parameter number for Get Parameter Procedure.

PNU (hex)	Name	Data Type	Access	PDO Mapping	Value	Saving to EEPROM
2100h	Get Parameter - Parameter Identify	UINT	RW	No	UINT (default: FFFFh)	No



Reading Servo parameter. In order to read Servo parameter do the following:

- Write parameter number to PNU 2100h
- Read the value from PNU 2101h

Example

- Write 2100h: 0002h (= Pn002)
- Read 2101h: 0000_0001h

The lower 16 bits contain information of Pn002. Interpretation from LSB to MSB:

- Pn002.0 = 1
- Pn002.1 = 0
- Pn002.2 = 0
- Pn002.3 = 0

In case of 32 bit parameters (e.g. Pn520) all 32 bits are relevant.

Get Parameter - Parameter Value The parameter value for Get Parameter Procedure.

PNU (hex)	Name	Data Type	Access	PDO Mapping	Value	Saving to EEPROM
2101h	Get Parameter - Parameter Value	DINT	RO	No	(default: 0)	No



Reading Servo parameter, refer to PNU 2100h.

Manufacturer Specific Objects

Set Parameter - Parameter Identify The parameter number for Set Parameter Procedure.

PNU (hex)	Name	Data Type	Access	PDO Mapping	Value	Saving to EEPROM
2102h	Set Parameter - Parameter Identify	UINT	RW	No	UINT (default: FFFFh)	No



Setting Servo parameter. In order to set Servo parameter do the following:

- Write parameter number to PNU 2102h
- Write the value to PNU 2103h

Example

- Write 2102h: 0002h (= Pn002)
- Write the value to PNU 2103h: 0000_0001h

The lower 16 bits contain information of Pn002. Interpretation from LSB to MSB:

- Pn002.0 = 1
- Pn002.1 = 0
- Pn002.2 = 0
- Pn002.3 = 0

In case of 32 bit parameters (e.g. Pn520) all 32 bits are relevant.

Set Parameter - Parameter Value The parameter value for Set Parameter Procedure.

PNU (hex)	Name	Data Type	Access	PDO Mapping	Value	Saving to EEPROM
2103h	Set Parameter - Parameter Value	DINT	RW	No	(default: 0)	No



Writing Servo parameter, refer to PNU 2102h.

User Parameter Configuration

PNU (hex)	Name	Data Type	Access	PDO Mapping	Value	Saving to EEPROM
2300h	User Parameter Configuration	UDINT	RW	No	0 to 1 (default: 1)	Yes

Data Description

Bit	Description	Value	Description
0	User Unit Setting The procedure is as follows: <ul style="list-style-type: none"> ■ General state diagram must be PROFIdrive "S1: Switching On Inhibited" or "S2: Ready For Switching On". ■ Set the bit to 0. ■ Set the relevant User Units objects. ■ Setting the bit to 1 to activate the "new" user units. ■ Save user units to non-volatile memory. ■ Perform power cycle to update. After that procedure, the relevant object values will be automatically updated to the "new" units. It is important to notice that the set value in the all writable Position User Unit objects will not be changed, but these values are now in the context of new position user unit.	0	User Unit setting enable
		1	Activate User Unit
1 to 31	Reserved		

Position User Unit

Number of encoder counts for One user position unit.

Position User Unit = (Numerator / Denominator) [inc].

(Default setting for Position User Unit: 1 [inc])

PNU (hex)	Name	Data Type	Access	PDO Mapping	Value	Saving to EEPROM
2301h	Position User Unit	Array UDINT[2]	RW	No	-	Yes

Data Description

Sub-index	Description	Value Range	Default Value
0	Numerator	$1 \leq \text{Value range} \leq 2^{31}-1$	1
1	Denominator	$1 \leq \text{Value range} \leq 2^{31}-1$	1



Position user unit ratio must be in the range of 1/4096 to 65536 for successful user unit group enable.

Refer to [Chap. 6.15.2 'Setting the Position Reference Unit' ...page 172](#)

Manufacturer Specific Objects

Velocity User Unit

Number of encoder counts per msec for One user velocity unit.

Velocity User Unit = (Numerator / Denominator) [inc/ms].

(Default setting for Velocity User Unit: 1 [inc/ms])

PNU (hex)	Name	Data Type	Access	PDO Mapping	Value	Saving to EEPROM
2302h	Velocity User Unit	Array UDINT[2]	RW	No	-	Yes

Data Description

Sub-index	Description	Value Range	Default Value
0	Numerator	$1 \leq \text{Value range} \leq 2^{31}-1$	1
1	Denominator	$1 \leq \text{Value range} \leq 2^{31}-1$	1



Velocity user unit ratio is only accepted, if max. motor speed will be in the range of 0 to 2^{31} with new velocity user units.

Refer to [Chap. 6.15.3 'Setting the Speed Reference Unit' ...page 177](#)

Acceleration User Unit

Number of encoder counts increments per s² for One user acceleration unit

Acceleration User Unit = (Numerator / Denominator) × 10,000 [inc/s²].

(Default setting for Acceleration User Unit: 10,000 [inc/s²]).

PNU (hex)	Name	Data Type	Access	PDO Mapping	Value	Saving to EEPROM
2303h	Acceleration User Unit	Array UDINT[2]	RW	No	-	Yes

Data Description

Sub-index	Description	Value Range	Default Value
0	Numerator	$1 \leq \text{Value range} \leq 2^{31}-1$	1
1	Denominator	$1 \leq \text{Value range} \leq 2^{31}-1$	1



Acceleration user unit ratio is only accepted, if parameter Max. Motor Acceleration (60C5h) will be in the range of 0 to 2^{31} with new acceleration user units.

Refer to [Chap. 6.15.4 'Setting the Acceleration Reference Unit' ...page 178](#)

Max. Motor Speed

This object specifies the maximum speed of the motor based on the value read from the driver during initialization.

PNU (hex)	Name	Data Type	Access	PDO Mapping	Value	Saving to EEPROM	Units
2312h	Max. Motor Speed	UDINT	RO	No	-	-	Vel. units

Max. Motor Acceleration This object specifies the maximum acceleration of the motor based on the value read from the driver during initialization.

PNU (hex)	Name	Data Type	Access	PDO Mapping	Value	Saving to EEPROM	Units
2313h	Max. Motor Acceleration	UDINT	RO	No	-	-	Acc. units

Max. Motor Torque This object specifies the maximum torque of the motor based on the value read from the driver during initialization.

PNU (hex)	Name	Data Type	Access	PDO Mapping	Value	Saving to EEPROM	Units
2314h	Max. Motor Torque	UINT	RO	No	-	-	0.1%*

* The rated motor torque is 100%.

Device Control

15.6 Device Control

Error Code

This object provides the alarm/warning code of the last error which occurred in device.

PNU (hex)	Name	Data Type	Access	PDO Mapping	Value	Saving to EEPROM
603Fh	Error Code	UINT	RO	Yes	–	No

Controlword (STW1)

The controlword consists of bits for:

- the controlling of the state,
- the controlling of operating modes and
- manufacturer specific options.

PNU (hex)	Name	Data Type	Access	PDO Mapping	Value	Saving to EEPROM
6040h	Controlword (STW1)	UINT	RW	RPZD	UINT (default: 0)	No

Data Description

Bit No	PROFIdrive Profile Data Description	Explanation	
		Status	Description
0	OFF	1 - ON	To be set to transition S2 ⇒ S3
		0 - OFF	The drive is ramped down along configured profile deceleration (6084h). When the motor is stopped, the drive unit returns to state "S2: Ready For Switching on". This command is interruptible.
1	Coast Stop (OFF2)	1 - No Coast Stop (no OFF 2)	To be set for transition S1 ⇒ S2. Note: Bit 0 must be reset (=0) for the transition S1 ⇒ S2.
		0 - Coast Stop (OFF 2)	The ramp down phase is determined on setting of Sigma-7 parameter Pn001.0. When the motor is stopped, the drive unit returns to state "S1: Switching On Inhibited". This command is not interruptible.
2	Quick Stop (OFF3)	1 - No Quick Stop (no OFF 3)	To be set for transition S1 ⇒ S2.
		0 - Quick Stop (OFF 3)	The ramp down phase is determined on setting of parameter 605Ah (Quick Stop Option Code). When the motor is stopped, the drive unit returns to state "S1: Switching On Inhibited". This command is not interruptible.
3	Enable Operation	1 - Enable Operation	To be set for transition S3 ⇒ S4. Change to servo drive state "SERVO_ON".

Bit No	PROFIdrive Profile Data Description	Explanation	
		Status	Description
		0 - Disable Operation	The ramp down phase is determined on setting of Sigma-7 parameter Pn001.0. When the motor is stopped, the drive unit returns to state "S3: Switched On". This command is not interruptible.
4 to 6	Operation mode specific		
7	Fault Ack (Reset)	0 ⇒ 1: Alarm/Warning reset	
8 to 9	Operation mode specific		
10	Control by PLC	1: Accepts the controller's control words. 0: Doesn't accept the controller's control words. Falling edge during Operation Enable state will cause 'Abnormal control state' alarm.	
11	Operation mode specific		
12	Negative torque limit	Torque limit enable bit 0: Disable	
13	Positive torque limit	1: Enable To use these torque limits, you have to set the following Servo Drive Parameters, using objects 2102h/2103h → Chap. 14.11 'Get/Set SERVOPACK Parameter Functionality' ...page 492 before you set Enable. Pn404 Forward External Torque Limit Pn405 Reverse External Torque Limit → Chap. 7.8.3 'External Torque Limits' ...page 214	
14 to 15	Not used	No effect	

Bit 0 to 3 and 7, 10

PROFIdrive Profile

Command	Bit of the PROFIdrive Profile Controlword (6040h)					
	Bit 10	Bit 7	Bit 3	Bit 2	Bit 1	Bit 0
Shutdown	1	–	–	1	1	0
Switch On	1	–	0	1	1	1
Switch On + Enable Operation	1	–	1	1	1	1
Coast Stop	1	–	–	–	0	–
Quick Stop	1	–	–	0	1	–
Ramp Stop	1	–	–	1	1	0
Disable Operation	1	–	0	1	1	1
Enable Operation	1	–	1	1	1	1
Fault Acknowledgement (Reset)	1	0 ⇒ 1	–	–	–	–

Bit 4, 5, 6, 8, 9 and 11

PROFIdrive Profile position mode

Bit No	Value	Definition
4	1	Do not reject traversing task
	0	Reject traversing task. The axis stops according to Halt Option Code (605Dh). For PROFIdrive standard compliance the setting should be 3 (Slow down with Max. Deceleration 60C6h).
5	1	No intermediate stop
	0	Intermediate Stop. The axis stops according to the current profile deceleration.
6	0 ⇔ 1	Activate traversing task
8	0	Not supported (Always 0)
9	0	Not supported (Always 0)
11	0 ⇔ 1	Start homing procedure
	1 ⇔ 0	Stop homing Procedure. The axis stops according to Homing Acceleration (609Ah).

PROFIdrive Profile velocity mode

Bit No	Value	Definition
4	1	Enable ramp generator
	0	Reset ramp generator. The axis stops according to Halt Option Code (605Dh). For PROFIdrive standard compliance the setting should be 3 (Slow down with Max. Deceleration 60C6h).
5	1	Unfreeze ramp generator
	0	Freeze ramp generator
6	1	Enable set point
	0	Disable set point. The axis stops according to Profile Deceleration (6084h)
8	0	Not supported (Always 0)
9	0	Not supported (Always 0)
11	0	Not supported (Always 0)

Profile Torque Mode

Bit No	Value	Definition
4	0	Reserved (Always 0)
5	0	Reserved (Always 0)
6	0	Reserved (Always 0)
8	0	The motion shall be executed or continued
	1	Axis shall be stopped according to the Halt Option Code (605Dh)
9	0	Not supported (Always 0)
11	0	Not supported (Always 0)

Statusword (ZSW1)

The statusword indicates the current state of the drive. No bits are latched. The statusword consists of bits for:

- the current state of the drive,
- the operating state of the mode and
- manufacturer specific options.

PNU (hex)	Name	Data Type	Access	PDO Mapping	Value	Saving to EEPROM
6041h	Statusword (ZSW1)	UINT	RO	TPZD	-	No

Data Description

Bit No	PROFIdrive Profile Data Description	Explanation
0	Ready to switch on	Refer to Notes below
1	Ready to operate	
2	Operation enabled	
3	Fault	
4	Coast Stop (OFF2)	1 - Coast Stop not activated. 0 - Coast Stop activated by Controlword (STW1).
5	Quick Stop (OFF3)	1 - Quick Stop not activated. 0 - Quick Stop activated by Controlword (STW1) or internally as a result of Safety requested event.
6	Switching on inhibited	Refer to Notes below
7	Warning	
8	Operation mode specific	Refer to Notes below
9	Control Requested	Drive is ready and Controlword (6040h) is processed
10	Target reached	Refer to Notes below Even if a fault occurs or main power is turned off or HWBB becomes active, it complies with the description below.
11 to 13	Operation mode specific	Refer to Notes below
14	Safety Active	It becomes 1 (active) when a motor is stopped by the hardwired base block function (HWBB) or Safety function is active by Safety Option Card. Safety State (without Safety Option Card): Bit 14 = HWBB Safety State (with Safety Option Card): Bit 14 = (PNU 2410h bit 8) or (PNU 2410h bit 9) or (PNU 2410h bit 10)
15	Operation mode specific	Refer to Notes below

Bit 0 to 3 and 6, 7

PROFIdrive Profile

Transitions	Bit of the PROFINET Statusword ZSW1 (6041h)					
	Bit 7	Bit 6	Bit 3	Bit 2	Bit 1	Bit 0
Not Ready to Switch On	–	0	0	0	0	0
S1: Switching On Inhibited	–	1	–	0	0	0

Transitions	Bit of the PROFINET Statusword ZSW1 (6041h)					
	Bit 7	Bit 6	Bit 3	Bit 2	Bit 1	Bit 0
S2: Ready for Switching On	–	0	0	0	0	1
S3: Switched On	–	0	0	0	1	1
S4: Operation	–	0	0	1	1	1
S51: Switching off (ramp stop)	–	0	0	0	1	1
S52: Switching off (quick stop)	–	0	0	0	1	1
Fault reaction Active	–	0	1	1	1	1
Fault	–	1	1	0	0	0
Warning has occurred	1	–	–	–	–	–

Note:

Internal limit active

If internal limit active of the Statusword 1 (ZSW1) is 1, this shall indicate that an internal limit is active. The internal limits are manufacturer-specific. The internal limit are active in the following cases:

- Software Position Limit (607Dh|00, 607Dh|01)
- N-OT, P-OT limit switch
- Torque Limit (PNU 60E0h, 60E1h, Rotatory: Pn402, Pn403, Pn404, Pn405; Linear: Pn483, Pn484, Pn404, Pn405).

The smallest value among the sets of data listed in the following table becomes the torque limit value:

Positive torque limit value		Negative torque limit value	
STW1 bit 13 = 0	STW1 bit 13 = 1	STW1 bit 12 = 0	STW1 bit 12 = 1
Pn402 (Pn482)	Pn402 (Pn482)	Pn403 (Pn483)	Pn403 (Pn483)
Positive Torque Limit (60E0h)	Pn404 Positive Torque Limit (60E0h)	Negative Torque Limit (60E1h)	Pn405 Negative Torque Limit (60E1h)

- Safety Active mode function execution is in progress (PNU 2410h bit 16).

➔ [Chap. 12.2.1 'Safety Functions' ...page 440](#)

In PROFIdrive Profile position mode the *Internal limit active* of Statusword 1 (ZSW1) is bit 15, in all other cases it is bit 11.

Bit 8, 10, 11, 12, 13, 15

PROFIdrive Profile position mode

Bit No	Value	Definition
8	0	Following error out of tolerance range Details: The "Position Actual Value" (6064h) is outside the allowed range of the "Following Error Window" (6065h) around a "Position Demand Value" for longer than the "Following Error Time Out" (6066h).
	1	Following error within tolerance range
10	0	Target position not reached
	1	Target position reached (The position actual value is located at the end of a traversing task in the positioning window)

Bit No	Value	Definition
11	0	Home position not yet set - no valid home position available.
	1	Home position set - homing procedure was executed and home position is valid.
12	0 ⇒ 1	Traversing task acknowledgment - it is acknowledged that a new traversing task or MDI setpoint was accepted.
	1 ⇒ 0	- Details: <ul style="list-style-type: none"> ■ Only acknowledgment of Controlword bit 6 negative edge. ■ If the DO General State Machine is not in state "S4: Operation", ZSW1 bit 12 is set to "0". After change back to state "S4: Operation", rising edge of STW1 bit 6 needed to set ZSW1 bit 12 again.
13	0	Drive moving - traversing task is executed. Speed is not equal 0.
	1	Drive stopped - signals that a traversing task has been completed or standstill for intermediate stop and stop.
15	–	Internal limit active (see above definition)

PROFIdrive Profile velocity mode

Bit No	Value	Definition
8	0	Speed error out of tolerance range
	1	Speed error within tolerance range Details: The difference between the "Target Velocity" (60FFh) and the "Velocity Actual Value" (606Ch) is within the "Velocity Window" (606Dh) longer than the "Velocity Window Time" (606Eh).
10	0	f or n not reached Details: Velocity Actual value < 606Fh Velocity Threshold
	1	Velocity Actual value ≥ 606Fh Velocity Threshold
11	–	Internal limit active (see above definition)
12 - 13	–	Reserved
15	–	Reserved

Profile Torque Mode

Bit No	Value	Safety SSx-PD condition	Definition
10	0	-	Halt (Bit 8 in Controlword) = 0: Target torque not reached Halt (Bit 8 in Controlword) = 1: The axis is decelerating.
		Safety SSx-PD Requested	Safety axis decelerating (Halt Bit 8 in Controlword has no effect)
	1	-	Halt (Bit 8 in Controlword) = 0: Target torque reached
		Safety SSx-PD Requested	Halt (Bit 8 in Controlword) = 1: The axis is stopped.

Bit No	Value	Safety SSx-PD condition	Definition
11	–		Internal limit active (see above definition)
12 to 13	–		Reserved
15	–		Reserved

Pole detection mode

Bit 13	Bit 12	Bit 10	
0	0	–	None
0	1	–	Pole Detection Completed
1	0	–	Pole Detection In Process
1	1	–	Reserved

Quick Stop Option Code

The parameter quick stop option code determines what action should be taken if the Quick Stop Function is executed by controlword 1 (STW1). It determines also the quick stop function in case of SS1 or SS2 Safety requested event, but this is not available in case of SERVOPACK Active Mode Function is enabled.

PNU (hex)	Name	Data Type	Access	PDO Mapping	Value	Saving to EEPROM
605Ah	Quick Stop Option Code	INT	RW	No	-3 to 3 (default: 2)	Yes

Data Description

Value	Data description	Explanation
-3 ^(*)	Slow down on Max. Deceleration (60C6h) by CW. QuickStop command and SMMO in case of Safety Requested.	Not PROFIdrive and PROFIsafe -SS1/SS2 standard compliance (No internal Quick Stop Slow down).
-2 ^(*)	Slow down on quick stop ramp by CW. Quick-Stop command and SMMO in case of Safety Requested.	Not PROFIdrive and PROFIsafe -SS1/SS2 standard compliance (No internal Quick Stop Slow down).
-1 ^(*)	Slow down on slow down ramp by CW. QuickStop command and SMMO in case of Safety Requested.	Not PROFIdrive and PROFIsafe -SS1/SS2 standard compliance (No internal Quick Stop Slow down).
0	Disable drive function	The stopping methods are determined by Sigma-7 Pn001.0.
1	Slow down on slow down ramp	
2	Slow down on quick stop ramp	PROFIdrive Profile standard compliance option.
3	Slow down on max. deceleration (60C6h)	PROFIdrive Profile standard compliance option.

Notes:

In Profile Torque Mode, the torque demand value is down to zero in max. torque slope.

(*1) Safety Monitoring Mode Only:

In this option the driver will stay in the state S4: Operation without internally slowing down the motor in case of SS1 or SS2 Safety Requested event. It is not applicable in case Active Mode function is Enabled.

Halt Option Code

In PROFIdrive velocity mode the halt option code determines the action during reset ramp generator bit 4 in Controlword. In PROFIdrive position mode the halt option code determines the action during reject traversing task bit 4 in Controlword.

PNU (hex)	Name	Data Type	Access	PDO Mapping	Value	Saving to EEPROM
605Dh	Halt Option Code	INT	RW	No	1 to 3 (default: 3)	Yes

Data Description

Value	Data description	Explanation
1	Slow down on slow down ramp (*)	Supported
2	Slow down on quick stop ramp (*)	Supported
3	Slow down on Max. Deceleration (60C6h) (*)	Supported

Notes

(*) In Profile Torque Mode, the torque demand value is down to zero in max. torque slope

Fault Reaction Option Code

This object defines the operation that is performed when an alarm is detected.

PNU (hex)	Name	Data Type	Access	PDO Mapping	Value	Saving to EEPROM
605Eh	Fault Reaction Option Code	INT	RW	No	0 to 3 (default: 2)	Yes

Data Description

Value	Data description
0	Disables the Servo Drive. (Turns OFF the servo.)
1	Slow down on slow down ramp and turn the servo off(*)
2	Slow down on quick stop ramp and turn the servo off (*)
3	Slow down on Max. Deceleration (60C6h) and turn the servo off (*)

Notes

The stopping methods when servo is turned OFF are determined by Pn001.0

(*) In Profile Torque Mode, the torque demand value is down to zero in max. torque slope.

For more details refer to [↪ Chap. 14.1 'Device Control' ...page 472.](#)

Modes of Operation

The parameter modes of operation switches the actually chosen operation mode.

PNU (hex)	Name	Data Type	Access	PDO Mapping	Value	Saving to EEPROM
6060h	Modes of Operation	INT	RW	Yes	-3 to 4 (default: 0)	Yes

Data Description

Value	Data description	Explanation
-3	PROFIdrive Profile Velocity mode	Supported
-2	PROFIdrive Profile Position mode	Supported
-1	Pole detection mode	Supported
0	No mode	
4	Profile Torque Mode	Supported



Reading the modes of operation only shows the value of modes of operation. The actual mode of the drive is reflected in the object modes of operation display. It may be changed by writing to modes of operation.

Appendix

Setting pole detection mode of operation enables the pole detection in which a magnetic pole of linear motor connected to Sigma-7 can be detected. When an incremental linear scale is used, the detected phase information will not be saved and thus, the mode of operation is required at every power-on.

When an absolute linear scale is used, detected information will be saved into both Sigma-7 and the scale connected to Sigma-7. In the following PROFIdrive General State Machine transition, the pole detection starts:

- From S3: Switched On to S4: Operation.

Transition command to S1: Switching On Inhibited during the pole detection will not stop the pole detection immediately only after the pole detection completion. Then the driver will be servo off and in S1: Switching On Inhibited state.

Reset application should not be done during pole detection process.

Modes of Operation Display

The Modes of Operation Display shows the current mode of operation. The meaning of the returned value corresponds to that of the Modes of Operation option code (6060h).

PNU (hex)	Name	Data Type	Access	PDO Mapping	Value	Saving to EEPROM
6061h	Modes of Operation Display	INT	RO	TPZD	-	No

Data Description

Refer to data description of [↔ Chap. 15.6 'Device Control' ...page 512.](#)



The actual mode is reflected in the Modes of Operation Display (6061h).

Controlword 2 (STW2)

The Controlword 2 consists of bits for:

- the controlling of the state,
- the controlling of operating modes and
- manufacturer specific options.

PNU (hex)	Name	Data Type	Access	PDO Mapping	Value	Saving to EEPROM
2503h	Controlword 2 (STW2)	UINT	RO	RPZD	-	No

Data Description

Bit No	Data description	Explanation
0	Absolute /Relative positioning mode	0 - Relative positioning (from Actual Position). 1 - Absolute positioning.
1 to 9	Reserved	
10	STW2 Control override	0 - STW2 control override is disabled (e.g. standard behavior Absolute /Relative motion is determined by MDI Mode (2538h) bit 0 and not by STW2 (2503h) bit 0) 1 - STW2 control override is enabled (e.g. Absolute /Relative motion is determined by STW2 (2503h) Bit 0 and MDI Mode (2538h) bit 0 is discarded)
11	Reserved	
12 to 15	Controller Sign-Of-Life	



Sign-Of-Life supported only If a clock-cycle synchronous application exists.

Device Control

Statusword 2 (ZSW2)

The Statusword 2 indicates the current state of the drive. No bits are latched. The Statusword 2 consists of bits for:

- the current state of the drive,
- the operating state of the mode and
- manufacturer specific options.

PNU (hex)	Name	Data Type	Access	PDO Mapping	Value	Saving to EEPROM
2504h	Statusword 2 (ZSW2)	UINT	RO	TPZD	-	No

Data Description

Bit No	Data description	Explanation
0	Negative limit switch	N-OT: 0 - Input N-OT Not Active 1 - Input N-OT Active
1	Positive limit switch	P-OT: 0 - Input P-OT Not Active 1 - Input P-OT Active
2	Homing switch	/DEC: 0 - Input /DEC Not Active 1 - Input /DEC Active
3	Positive Software Position Limit	0 - Positive Software Position Limit (607Dh 01) Not Active 1 - Positive Software Position Limit (607Dh 01) Active
4	Negative Software Position Limit	0 - Negative Software Position Limit (607D 00) Not Active 1 - Negative Software Position Limit (607D 00) Active
5	Torque Limit	0: Torque limit is disabled. 1: Torque limit is enabled.
6 to 11	reserved	
12 to 15	DO Sign-Of-Life	



Sign-Of-Life supported only if a clock-cycle synchronous application exists

15.7 PROFIdrive Position Mode

Position Range Limit Designation

PNU (hex)	Name	Data Type	Access	PDO Mapping	Value	Saving to EEPROM
2400h	Position Range Limit Designation	UINT	RW	No	0 to 3 (default: 0)	Yes

Data Description

Value	Position Range limit designation for:
0	Off
1	Shortest route
2	Fixed rotational direction, "positive"
3	Fixed rotational direction, "negative"



When the mode "Shortest route" is selected, the drive always moves the physical shortest distance to the target and adjusts the sign of the running speed accordingly. For the modes "Fixed rotational direction..." the drive moves always in that direction, specified by the appropriate mode.

Target Position in Range The warped target command value when Position range limit executed.

PNU (hex)	Name	Data Type	Access	PDO Mapping	Value	Saving to EEPROM	Units
2401h	Target Position in Range	DINT	RO	TPZD	-	No	Pos. units

Actual Position in Range The warped actual position value when Position range limit executed.

PNU (hex)	Name	Data Type	Access	PDO Mapping	Value	Saving to EEPROM	Units
2402h	Actual Position in Range	DINT	RO	TPZD	-	No	Pos. units

PROFIdrive Position Mode

Traversing Block Selection (SATZANW) Traversing block selection.

PNU (hex)	Name	Data Type	Access	PDO Mapping	Value	Saving to EEPROM
2532h	Traversing Block Selection (SATZANW)	UINT	RW	RPZD	-	No

Data Description

Bits	Description
0 to 9	Number of the motion record in the program storage intended to start (value range: 0 to 1023). A minimum number of 64 records (bits 0 to 5) shall be supported by the drive. Bits 0 to 9 are only relevant in Program submode.
10 to 14	Reserved for future use by PROFIdrive profile
15	Mode switch for selection of submodes: <ul style="list-style-type: none"> ■ 1 - Activation of the MDI submode. If there is a program still running (extended state machine not in the Basic State), the positioning interface will change to MDI Submode only after the program ends or is terminated (STW1 bit 4). ■ 0 - Deactivation of the MDI submode. If there is a MDI motion command still executed the path interpolation shall stop and the MDI motion command shall be rejected.

Actual Traversing Block (AKTSATZ) Traversing block selected.

PNU (hex)	Name	Data Type	Access	PDO Mapping	Value	Saving to EEPROM
2533h	Actual Traversing Block (AKTSATZ)	UINT	RO	TPZD	-	No

Data Description

Bits	Description
0 to 9	Number of the motion record actually active (executed by the path interpolation). 64 records (bits 0 to 5) are supported by the drive. Bits 0 to 5 are only relevant in Program submode (in MDI submode and while no program is being executed the number should be 0).
10 to 14	Reserved for future use by PROFIdrive profile
15	Status of Mode switch: <ul style="list-style-type: none"> ■ 1 - MDI submode active. The input values for the motion record will be taken out of the signals MDI_MOD, MDI_TARPOS, MDI_VELOCITY, MDI_ACC and MDI_DEC. ■ 0 - Program submode active. The initial motion record for the start of the motion task will be taken out of bits 0 to 5 of this signal.

MDI Acceleration (MDI_ACC)

The MDI acceleration is the normalized value to parameter 6083h (Profile Acceleration). The interpretation of this value is: FFFFh => 100% of 60C5h (Max. Acceleration).

PNU (hex)	Name	Data Type	Access	PDO Mapping	Value	Saving to EEPROM	Units
2536h	MDI Acceleration (MDI_ACC)	UINT	RW	RPZD	UINT (default: 0)	No	N2*

* FFFFh => 100% of 60C5h (max. acceleration)

MDI Deceleration (MDI_DEC)

The MDI Deceleration is the normalized value to parameter 6084h (Profile Deceleration). The interpretation of this value is: FFFFh => 100% of 60C6h (Max. Deceleration).

PNU (hex)	Name	Data Type	Access	PDO Mapping	Value	Saving to EEPROM	Units
2537h	MDI Deceleration (MDI_DEC)	UINT	RW	RPZD	UINT (default: 0)	No	N2*

* FFFFh => 100% of 60C5h (Max. Acceleration)

MDI Mode (MDI_MOD)

Sets the mode of MDI traversing block.

PNU (hex)	Name	Data Type	Access	PDO Mapping	Value	Saving to EEPROM
2538h	MDI Mode (MDI_MOD)	UINT	RW	RPZD	UINT (default: 0)	No

Data Description

Bits	Description
0	<p>Absolute / Relative positioning mode (PNU 2400h=0):</p> <ul style="list-style-type: none"> ■ 1 - Absolute positioning. The target position in the signal MDI_TARPOS defines the absolute target position for the motion. ■ 0 - Relative positioning. The target position in the signal MDI_TARPOS defines the relative target position for the motion related to the actual axis position. <p>Absolute / Offset target command in Positioning in range mode execution (PNU 2400h!=0):</p> <ul style="list-style-type: none"> ■ 1 - Absolute Target command. The target position in the signal MDI_TARPOS is defined as absolute positioning in range target. ■ 0 - Offset Target command. The target position in the signal MDI_TARPOS is defined as offset from previous target positioning in range.
1 to 15	Reserved for future use by PROFIdrive profile

PROFIdrive Position Mode

Traversing Block Task Mode Sets the influence of the task for the traversing block.

PNU (hex)	Name	Data Type	Access	PDO Mapping	Value	Saving to EEPROM
2610h	Traversing Block Task Mode	Array UDINT[64]	RW	No	0 to 1(default: 0)	Yes

Data Description

Bits	Description
0	<p>Absolute / Relative positioning mode:</p> <ul style="list-style-type: none"> 1 - Absolute positioning. The Traversing Block Target Position is defined as absolute target position for the motion. 0 - Relative positioning. The Traversing Block Target Position is defined as relative target position for the motion related to the actual axis position. <p>Absolute / Offset target command in Positioning in range mode execution (PNU 2400h!=0):</p> <ul style="list-style-type: none"> 1 - Absolute Target command. The Traversing Block Target Position is defined as absolute positioning in range target. 0 - Offset Target command. The Traversing Block Target Position is defined as offset from previous target positioning in range.
1 to 15	Reserved for future use by PROFIdrive profile
16 to 31	Reserved

Traversing Block Target Position

The target position is the position that the drive should move to in PROFIdrive position profile mode using the settings of motion Traversing Block parameters such as velocity, acceleration, deceleration.

PNU (hex)	Name	Data Type	Access	PDO Mapping	Value	Saving to EEPROM	Units
2611h	Traversing Block Target Position	Array DINT[64]	RW	No	DINT (default: 0)	Yes	Pos. units

Traversing Block Profile Velocity

The profile velocity is the velocity normally attained at the end of the acceleration ramp during a profiled move and is valid for both directions of motion. The profile velocity is given in user defined speed units.

PNU (hex)	Name	Data Type	Access	PDO Mapping	Value	Saving to EEPROM	Units
2612h	Traversing Block Profile Velocity	Array UDINT[64]	RW	No	0 to $2^{31}-1$ (default: 0)	Yes	Vel. units

Traversing Block Profile Acceleration

The profile acceleration for the traversing block is given in user defined acceleration units.

PNU (hex)	Name	Data Type	Access	PDO Mapping	Value	Saving to EEPROM	Units
2613h	Traversing Block Profile Acceleration	Array UDINT[64]	RW	No	0 to $2^{31}-1$ (default: 0)	Yes	Acc. units

Traversing Block Profile Deceleration

The profile deceleration for the traversing block is given in user defined acceleration units.

PNU (hex)	Name	Data Type	Access	PDO Mapping	Value	Saving to EEPROM	Units
2614h	Traversing Block Profile Deceleration	Array UDINT[64]	RW	No	0 to $2^{31}-1$ (default: 0)	Yes	Acc. units

Target Position

The target position is the position that the drive should move to in position profile mode using the current settings of motion control parameters such as velocity, acceleration, deceleration, motion profile type etc.

PNU (hex)	Name	Data Type	Access	PDO Mapping	Value	Saving to EEPROM	Units
607Ah	Target Position	DINT	RW	RPZD	DINT (default: 0)	-	Pos. units

Position Range Limit

This object shall indicate the configured maximal and minimal position range limits. It shall limit the numerical range of the input value. On reaching or exceeding these limits, the input value shall wrap automatically to the other end of the range. Wrap-around of the input value may be prevented by setting software position limits as defined in Software Position Limit object (607Dh). The values shall be given in user-defined position units.

PNU (hex)	Name	Data Type	Access	PDO Mapping	Value	Saving to EEPROM	Units
607Bh	Position Range Limit	Array DINT[2]	RW	No	-	Yes	Pos. units

Subindex	Name	Value Range	Default Value
0	Min. Position Range Limit	$-2^{31} \leq \text{Value range} \leq 0$	-2^{31}
1	Max. Position Range Limit	$0 \leq \text{Value range} \leq 2^{31}-1$	$2^{31}-1$



Please refer to parameter 2400h → Chap. 15.7 'PROFIdrive Position Mode' ...page 523.

PROFIdrive Position Mode

Software Position Limit

Software Position Limit contains the sub-parameters 'Min. Position Limit' and 'Max. Position Limit'. These parameters define the absolute position limits for the position demand value and the position actual value. Every new target position must be checked against these limits. The limit positions are specified in position units (same as target position) and are always relative to the machine home position.

Software limit change is not allowed in Operation enable and Quick stop state.

Movement operation from out of limits condition is allowed only to the negative direction of the software limit. The setting of Min. Position Limit > Max. Position is not allowed.

Software limit disable in case of setting Max/Min DINT value correspondingly.

PNU (hex)	Name	Data Type	Access	PDO Mapping	Value	Saving to EEPROM	Units
607Dh	Software Position Limit	Array DINT[2]	RW	No	-	Yes	Pos. units

Data Description

Subindex	Name	Value Range	Default Value
0	Min. Position Limit	DINT	-2 ³¹
1	Max. Position Limit	DINT	2 ³¹ -1

- For Incremental Encoder
Software position limit values are activated once the homing is completed after power-up.
- For Absolute Encoder
When an absolute encoder is connected to the SERVOPACK, no homing has to be done, that the software position limits are activated.

Max. Profile Velocity

Max. Profile Velocity is the maximum allowed speed in either direction during a profiled move. It is given in the same units as Profile Velocity (6081h).

PNU (hex)	Name	Data Type	Access	PDO Mapping	Value	Saving to EEPROM	Units
607Fh	Max. Profile Velocity	UDINT	RW	No	0 to Max. Motor Speed (default: Max. Motor Speed*)	Yes	Vel. units

* Max. motor speed taken from the driver during initialization.

Profile Velocity

The profile velocity is the velocity normally attained at the end of the acceleration ramp during a profiled move and is valid for both directions of motion. The profile velocity is given in user defined speed units. It is converted to position increments per second using the velocity encoder factor.

PNU (hex)	Name	Data Type	Access	PDO Mapping	Value	Saving to EEPROM	Units
6081h	Profile Velocity	UDINT	RW	RPZD	0 to Max. Profile Velocity (default: 0)	Yes	Vel. units

Profile Acceleration The profile acceleration is given in user defined acceleration units.

PNU (hex)	Name	Data Type	Access	PDO Mapping	Value	Saving to EEPROM	Units
6083h	Profile Acceleration	UDINT	RW	RPZD	0 to Max. Acceleration (60C5h) (default: 0)	Yes	Acc. units

Profile Deceleration The profile deceleration is given in the same units as profile acceleration. If this parameter is not supported, then the profile acceleration value is also used for deceleration.

PNU (hex)	Name	Data Type	Access	PDO Mapping	Value	Saving to EEPROM	Units
6084h	Profile Deceleration	UDINT	RW	RPZD	0 to Max. Deceleration (60C6h) (default: 0)	Yes	Acc. units

Quick Stop Deceleration The quick stop deceleration is the deceleration used to stop the motor if the 'Quick Stop' command is given and the Quick Stop Option Code (605Ah) → '[Quick Stop Option Code](#)' ...[page 518](#) is set to 2.

PNU (hex)	Name	Data Type	Access	PDO Mapping	Value	Saving to EEPROM	Units
6085h	Quick Stop Deceleration	UDINT	RW	RPZD	0 to Max. Deceleration (60C6h) (default: Max. Motor Deceleration)	Yes	Acc. units

* The deceleration calculated on the basis of taken value from the driver during initialization.

PROFIdrive Position Mode

Max. Acceleration

This object indicates the configured maximal acceleration. It is used to limit the acceleration to an acceptable value in order to prevent the motor and the moved mechanics from being destroyed.

PNU (hex)	Name	Data Type	Access	PDO Mapping	Value	Saving to EEPROM	Units
60C5h	Max. Acceleration	UDINT	RW	No	0 to Max. Motor Acceleration* (default: Max. Motor Acceleration)	Yes	Acc. units

* Max. Motor Acceleration calculated on the basis of taken value from the driver during initialization.

Valid setting value condition is as follows: Max. Acceleration (60C5h) \geq Profile Acceleration (6083h)



Max. Motor Deceleration is equal to Max. Motor Acceleration.

Max. Deceleration

This object indicates the configured maximal deceleration. It is used to limit the deceleration to an acceptable value in order to prevent the motor and the moved mechanics from being destroyed.

PNU (hex)	Name	Data Type	Access	PDO Mapping	Value	Saving to EEPROM	Units
60C6h	Max. Deceleration	UDINT	RW	No	0 to Max. Motor Deceleration* (default: Max. Motor Deceleration)	Yes	Acc. units

* Max. Motor Deceleration calculated on the basis of taken value from the driver during initialization.

Valid setting value condition is as follows: Max. Deceleration (60C6h) \geq Profile Deceleration (6084h) and Max. Deceleration (60C6h) \geq Quick Stop Deceleration (6085h)



Max. Motor Deceleration is equal to Max. Motor Acceleration.

15.8 Homing Function

Home Offset

The home offset object is the difference between the zero position for the application and the machine home position (found during homing), it is measured in position units.

PNU (hex)	Name	Data Type	Access	PDO Mapping	Value	Saving to EEPROM	Units
607Ch	Home Offset	DINT	RW	No	DINT (default: 0)	Yes	Pos. units

- For Incremental and Absolute Encoder
During homing the machine home position is found and once the homing is completed the zero position is offset from the home position by adding the home offset to the home position.

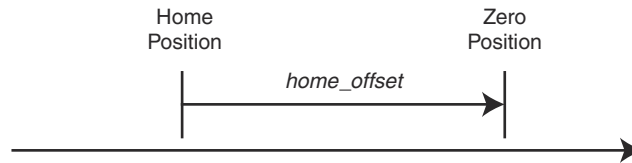


Fig. 374: Home Offset 607Ch

Homing Method

The homing method object determines the method that will be used during homing.

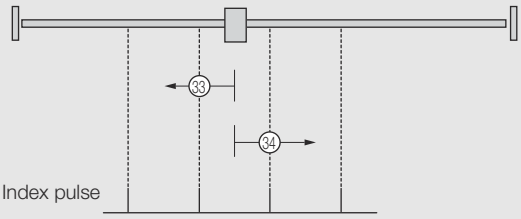
PNU (hex)	Name	Data Type	Access	PDO Mapping	Value	Saving to EEPROM
6098h	Homing Method	INT	RW	No	0 to 35 (default: 0)	Yes

Data Description of Homing Method (6098h)

Value	Definition	Description
0	No homing operation required	No homing (Default value)
1	Homing on the negative limit switch and index pulse	
2	Homing on the positive limit switch and index pulse	

Homing Function

Value	Definition	Description
3 to 4	Homing on the positive home switch and index pulse	
5 to 6	Homing on the negative home switch and index pulse	
7 to 16	Other method (Skipped description)	Not supported
17	Homing on the negative limit switch Same homing as method 1 (without an index pulse)	Refer to method 1
18	Homing on the positive limit switch Same homing as method 2 (without an index pulse)	Refer to method 2
19 to 20	Homing on the positive home switch Same homing as method 3 and 4 (without an index pulse)	
21 to 22	Homing on the negative home switch Same homing as method 5 and 6 (without an index pulse)	Refer to method 5 and 6
23 to 32	Other method (Skipped description)	Not supported

Value	Definition	Description
33 to 34	Homing on index pulse	
35	Homing on the current position	Supported
36 to 127	Reserved	No effect

Note: The index pulse is recognized as the encoder zero signal (phase-C).

Homing Speeds

This entry in the object dictionary defines the speeds used during homing and is given in user velocity units.

PNU (hex)	Name	Data Type	Access	PDO Mapping	Value	Saving to EEPROM	Units
6099h	Homing Speeds	UDINT[2]	RW	No	-	Yes	Vel. units

Data Description

Subindex	Name	Value Range	Default Value
0	Speed during search for switch	0 to Max. Motor Speed	0
1	Speed during search for zero	0 to Max. Motor Speed	0

Homing Acceleration

The homing acceleration establishes the acceleration to be used for all accelerations and decelerations with the standard homing modes and is given in acceleration units.

PNU (hex)	Name	Data Type	Access	PDO Mapping	Value	Saving to EEPROM	Units
609Ah	Homing Acceleration	UDINT	RW	RPZD	0 to Max. Motor Acceleration	Yes	Acc. units

15.9 Position Control Function

Position Demand Value This object provides the demanded position value in user position units.

PNU (hex)	Name	Data Type	Access	PDO Mapping	Value	Saving to EEPROM	Units
6062h	Position Demand Value	DINT	RO	TPZD	-	-	Pos. units

Position Actual Internal Value The actual value of the position measurement device is one of the two input values of the closed loop position control. The data unit is defined as increments.

PNU (hex)	Name	Data Type	Access	PDO Mapping	Value	Saving to EEPROM	Units
6063h	Position Actual Internal Value	DINT	RO	TPZD	-	-	Increments

Position Actual Value This object represents the actual value of the position measurement device in defined units.

PNU (hex)	Name	Data Type	Access	PDO Mapping	Value	Saving to EEPROM	Units
6064h	Position Actual Value	DINT	RO	TPZD	-	-	Pos. units

Following Error Window This parameter indicates the configured range of tolerated position values symmetrically to the position demand value. If the position actual value is out of the following error window, a following error occurs. A following error may occur when a drive is blocked, unreachable profile velocity occurs, or at wrong closed-loop coefficients.

PNU (hex)	Name	Data Type	Access	PDO Mapping	Value	Saving to EEPROM	Units
6065h	Following Error Window	UDINT	RO	No	0 to $(2^{31}-1)$ (default: 32)	Yes	Pos. units

Following Error Time Out A position actual value outside the allowed range of the following error window around a position demand value for longer than the following error time out will toggle the following error bit in the Statusword.

PNU (hex)	Name	Data Type	Access	PDO Mapping	Value	Saving to EEPROM	Units
6066h	Following Error Time Out	UINT	RW	No	UINT (default: 0)	Yes	ms

Position Window The position window defines a symmetrical range of accepted positions relatively to the target position. If the actual value of the position encoder is within the position window, this target position is regarded as reached.

PNU (hex)	Name	Data Type	Access	PDO Mapping	Value	Saving to EEPROM	Units
6067h	Position Window	UDINT	RW	No	0 to $(2^{31}-1)$ (default: 32)	Yes	Pos. units

Position Window Time

When the actual position is within the position window during the defined position window time which is given in multiples of milliseconds, the corresponding bit 10 target reached in the Statusword will be set to one.

PNU (hex)	Name	Data Type	Access	PDO Mapping	Value	Saving to EEPROM	Units
6068h	Position Window Time	UINT	RW	No	UINT (default: 0)	Yes	ms

Following Error Actual Value

This object provides the actual value of the following error.

PNU (hex)	Name	Data Type	Access	PDO Mapping	Value	Saving to EEPROM	Units
60F4h	Following Error Actual Value	DINT	RO	TPZD	-	-	Pos. units

Position Demand Internal Value

This output of the trajectory generator in profile position mode is an internal value using increments as unit what is expressed with a position demand value in increments. To save calculation time for some applications, this object is additionally introduced to the Position Demand Value (6062h).

PNU (hex)	Name	Data Type	Access	PDO Mapping	Value	Saving to EEPROM	Units
60FCh	Position Demand Internal Value	DINT	RO	TPZD	-	-	Increments

15.10 PROFIdrive Velocity Mode

Speed Setpoint A (NSOLL_A) The speed setpoint A is the normalized value to parameter 60FFh (Target Velocity).

PNU (hex)	Name	Data Type	Access	PDO Mapping	Value	Saving to EEPROM	Units
2505h	Speed Setpoint A (NSOLL_A)	INT	RW	RPZD	INT (default: 0)	Yes	N2 *

* 4000h => 100% of Max. Profile Velocity (607Fh) / 2

For example, if Max. Profile Velocity (607Fh) contains 6000 rpm, then 4000h = 3000rpm.

Speed Actual Value A (NIST_A) The speed actual value A is the normalized value to parameter 606Ch (Velocity Actual Value).

PNU (hex)	Name	Data Type	Access	PDO Mapping	Value	Saving to EEPROM	Units
2506h	Speed Actual Value A (NIST_A)	INT	RO	TPZD	INT (default: 0)	Yes	N2 *

* 4000h => 100% of Max. Profile Velocity (607Fh) / 2

For example, if Max. Profile Velocity (607Fh) contains 6000 rpm, then 4000h = 3000rpm.

Speed Setpoint B (NSOLL_B) The speed setpoint B is the normalized value to parameter 60FFh (Target Velocity).

PNU (hex)	Name	Data Type	Access	PDO Mapping	Value	Saving to EEPROM	Units
2507h	Speed Setpoint B (NSOLL_B)	DINT	RW	RPZD	DINT (default: 0)	Yes	N4 *

* 40000000h => 100% of Max. Profile Velocity (607Fh) / 2

For example, if Max. Profile Velocity (607Fh) contains 6000 rpm, then 40000000h = 3000rpm.

Speed Actual Value B (NIST_B) The speed actual value B is the normalized value to parameter 606Ch (Velocity Actual Value).

PNU (hex)	Name	Data Type	Access	PDO Mapping	Value	Saving to EEPROM	Units
2508h	Speed Actual Value B (NIST_B)	DINT	RO	TPZD	DINT (default: 0)	Yes	N4 *

* 40000000h => 100% of Max. Profile Velocity (607Fh) / 2

For example, if Max. Profile Velocity (607Fh) contains 6000 rpm, then 40000000h = 3000rpm.

Velocity Demand Value

The output value of the trajectory generator may be corrected by the output value of the position control function. It is then provided as a demand value for the velocity controller and given in the velocity units.

PNU (hex)	Name	Data Type	Access	PDO Mapping	Value	Saving to EEPROM	Units
606Bh	Velocity Demand Value	DINT	RO	TPZD	-	-	Vel. units

Velocity Actual Value

The velocity actual value is also represented in velocity units and is coupled to the velocity used as input to the velocity controller.

PNU (hex)	Name	Data Type	Access	PDO Mapping	Value	Saving to EEPROM	Units
606Ch	Velocity Actual Value	DINT	RO	TPZD	-	-	Vel. units

Velocity Window

The velocity window monitors whether the required process velocity has been achieved after an eventual acceleration or deceleration (braking) phase.

PNU (hex)	Name	Data Type	Access	PDO Mapping	Value	Saving to EEPROM	Units
606Dh	Velocity Window	UINT	RW	No	UINT (default: 0)	Yes	Vel. units

Velocity Window Time

The corresponding bit 10 target reached is set in the Statusword when the difference between target velocity and the velocity actual value is within the velocity window longer than the velocity window time.

The value of the velocity window time is given in multiples of milliseconds.

PNU (hex)	Name	Data Type	Access	PDO Mapping	Value	Saving to EEPROM	Units
606Eh	Velocity Window Time	UINT	RW	No	UINT (default: 0)	Yes	ms

Velocity Threshold

This object shall indicate the configured velocity threshold that determines if velocity actual value is exceeded or reached to threshold value.

PNU (hex)	Name	Data Type	Access	PDO Mapping	Value	Saving to EEPROM	Units
606Fh	Velocity Threshold	UINT	RW	No	UINT (default: 0)	Yes	Vel. units

PROFIdrive Velocity Mode

Target Velocity

The target velocity is the input for the trajectory generator and the value is given in velocity units.

PNU (hex)	Name	Data Type	Access	PDO Mapping	Value	Saving to EEPROM	Units
60FFh	Target Velocity	DINT	RW	RPZD	-(Max. Profile Velocity (607Fh)) to Max. Profile Velocity (607Fh) (default: 0)	-	Vel. units

15.11 Profile Torque Mode

Target Torque

This parameter is the input value for the torque controller in Profile Torque Mode.

PNU (hex)	Name	Data Type	Access	PDO Mapping	Value	Saving to EEPROM	Units
6071h	Target Torque	INT	RW	RPZD	-(Max. Torque (6072h)) to Max. Torque (6072h) (default: 0)	–	0.1%*

* The rated motor torque is 100%.

Max. Torque

This value represents the maximum permissible torque in the motor.

PNU (hex)	Name	Data Type	Access	PDO Mapping	Value	Saving to EEPROM	Units
6072h	Max. Torque	UINT	RW	No	Max. Torque \leq Max. Motor Torque (default: Max. Motor Torque**)	Yes	0.1%*

* The rated motor torque is 100%.

** Max. Motor Torque taken from the driver during initialization.

Valid setting value condition is as follows: Max. Torque \geq ABS(Target Torque (6071h)) and Max. Torque \geq Pos. Torque Limit (60E0h) and Max. Torque \geq Neg. Torque Limit (60E1h)

Torque Demand Value

This parameter is the output value of the torque limit function (if the torque control and power-stage function are available).

PNU (hex)	Name	Data Type	Access	PDO Mapping	Value	Saving to EEPROM	Units
6074h	Torque Demand Value	INT	RO	TPZD	–	–	0.1%*

* The rated motor torque is 100%.

Torque Actual Value

The torque actual value corresponds to the instantaneous torque in the drive motor.

PNU (hex)	Name	Data Type	Access	PDO Mapping	Value	Saving to EEPROM	Units
6077h	Torque Actual Value	INT	RO	TPZD	–	–	0.1%*

* The rated motor torque is 100%.

Profile Torque Mode

Torque Slope

This parameter describes the rate of change of torque.

PNU (hex)	Name	Data Type	Access	PDO Mapping	Value	Saving to EEPROM	Units
6087h	Torque Slope	UDINT	RW	RPZD	0 to $(2^{31}-1)$ (default: 0)	Yes	0.1%/s*

* The rated motor torque is 100%.

Positive Torque Limit Value

This object sets the positive torque limit value. Set the value in units of 0.1% of the motor rated torque.

PNU (hex)	Name	Data Type	Access	PDO Mapping	Value	Saving to EEPROM	Units
60E0h	Positive Torque Limit Value	UINT	RW	Yes	0 to Max. Torque (6072h) (default: default: Max. Motor Torque**)	Yes	0.1%*

* The rated motor torque is 100%.

** Max. Motor Torque taken from the driver during initialization.

Negative Torque Limit Value

This object sets the negative torque limit value. Set the value in units of 0.1% of the motor rated torque.

PNU (hex)	Name	Data Type	Access	PDO Mapping	Value	Saving to EEPROM	Units
60E1h	Negative Torque Limit Value	UINT	RW	Yes	0 to Max. Torque (6072h) (default: Max. Motor Torque**)	Yes	0.1%*

* The rated motor torque is 100%.

** Max. Motor Torque taken from the driver during initialization.

15.12 Touch Probe Function

Touch Probe Function This object indicates the configured function of the touch probe.

PNU (hex)	Name	Data Type	Access	PDO Mapping	Value	Saving to EEPROM
60B8h	Touch Probe Function	UINT	RW	RPZD	UINT (default: 0)	-



*Bit 0 to 7 for touch probe 1, bit 8 to 15 for touch probe 2.
60B8h Bit2/10 cannot be changed after 60B8h Bit4/12 has been set to 1.*

Data Description

Bit No	Value	Definition
0	0	Switch off touch probe 1
	1	Enable touch probe 1
1	0	Trigger first event
	1	Continuous
2	0	Trigger with touch probe 1 input
	1	Trigger with zero signal of position encoder
3	-	Reserved
4	0	Switch off sampling at touch probe 1
	1	Enable sampling at touch probe 1
5	-	Not supported
6, 7	0	User-defined (not used)
8	0	Switch off touch probe 2
	1	Enable touch probe 2
9	0	Trigger first event
	1	Continuous
10	0	Trigger with touch probe 2 input
	1	Trigger with zero signal of position encoder
11	0	Reserved
12	0	Switch off sampling at touch probe 2
	1	Enable sampling at touch probe 2
13	0	Not supported
14, 15	0	User-defined (not used)

Touch Probe Function

Touch Probe Status

This object provides the status of the touch probe.

PNU (hex)	Name	Data Type	Access	PDO Mapping	Value	Saving to EEPROM
60B9h	Touch Probe Status	UINT	RW	TPZD	UINT (default: 0)	-



Bit 0 to 7 for touch probe 1, bit 8 to 15 for touch probe 2.

Data Description

Bit No	Value	Definition
0	0	Touch probe 1 is switched off
	1	Touch probe 1 is enabled
1	0	Touch probe 1 no value stored
	1	Touch probe 1 value stored
2	0	Not supported
3 to 6	0	Reserved
7	0, 1	Shall toggle with every update of Touch probe 1 value stored *1
8	0	Touch probe 2 is switched off
	1	Touch probe 2 is enabled
9	0	Touch probe 2 no value stored
	1	Touch probe 2 value stored
10	0	Not supported
11 to 14	0	Reserved
15	0, 1	Shall toggle with every update of Touch probe 2 value stored *1

*1 If the continuous latch is enabled (60B8h bit 1 = 1 or bit 9 = 1), bit 7 or bit 15 of 60B9h is toggled with every update of touch probe value stored.

Touch Probe 1 Position Value

This object provides the position value of the touch probe 1. The value is given in user-defined position units.

PNU (hex)	Name	Data Type	Access	PDO Mapping	Value	Saving to EEPROM	Units
60BAh	Touch Probe 1 Position Value	DINT	RO	TPZD	-	-	Pos. units



This value is in perspective of application position coordinate. It means that the value is only valid after Homing and Touch probe capturing execution.

Touch Probe 2 Position Value

This object provides the position value of the touch probe 2. The value is given in user-defined position units.

PNU (hex)	Name	Data Type	Access	PDO Mapping	Value	Saving to EEPROM	Units
60BCh	Touch Probe 2 Position Value	DINT	RO	TPZD	-	-	Pos. units



This value is in perspective of application position coordinate. It means that the value is only valid after Homing and Touch probe capturing execution.

15.13 Digital Inputs/Outputs

Digital Inputs

This index defines simple digital inputs for drives.

PNU (hex)	Name	Data Type	Access	PDO Mapping	Value	Saving to EEPROM
2521h	Digital Inputs	UINT	RO	TPZD	-	-

Bits of Digital Inputs (2521h)

Bits	Data Description	Explanation
0	SI0	SI0 port input
1	SI1	SI1 port input
2	SI2	SI2 port input
3	SI3	SI3 port input
4	SI4	SI4 port input
5	SI5	SI5 port input
6	SI6	SI6 port input
7	Reserved	
8	HWBB1	Hardwired base block signal input 1 - Not applicable if a safety card is connected
9	HWBB2	Hardwired base block signal input 2 - Not applicable if a safety card is connected
10	SRI_A1	Input Signal - Only applicable if a safety card is connected
11	SRI_A2	Input Signal - Only applicable if a safety card is connected
12	SRI_B1	Input Signal - Only applicable if a safety card is connected
13	SRI_B2	Input Signal - Only applicable if a safety card is connected
14	EDM_A	Output Signal - Only applicable if a safety card is connected
15	EDM_B	Output Signal - Only applicable if a safety card is connected



Input signals SI0 – SI6, HWBBx, SRI_Ax , SRI_Bx:

0 – Signal state is Low (Close)

1 – Signal state is High (Open)

Output EDM_A and EDM_B:

0 – Signal state is High (Open)

1 – Signal state is Low (Close)

SI0 – SI6 are user-defined by setting servo parameter.

Digital Outputs

This index defines simple digital outputs for drives.

PNU (hex)	Name	Data Type	Access	PDO Mapping	Value	Saving to EEPROM
2522h	Digital Outputs	UINT	RW	RPZD	UINT (default: 0)	-

Bits of Digital Outputs (2522h)

Bits	Data Description	Explanation
0	SO1	SO1 port output
1	SO2	SO2 port output
2	SO3	SO3 port output
3 - 7	Reserved	Should not be used
8 - 15	Manufacturer specific	No signal reference (No effect)



SOx are defined by the user by setting servo parameter.

0 – Switch off Command

1 – Switch on Command

To output these signals, set servo parameter Pn50E, Pn50F and Pn510 to 0.

16 Maintenance

16.1 Overview

This chapter provides information on the meaning of, causes of, and corrections for alarms and warnings.

16.2 Inspections and Part Replacement

16.2.1 Overview

This section describes inspections and part replacement for SERVOPACKs.

16.2.2 Inspections

Perform the inspections given in the following table at least once every year for the SERVOPACK. Daily inspections are not required.

Item	Frequency	Inspection	Correction
Exterior	At least once a year	Check for dust, dirt, and oil on the surfaces.	Clean with compressed air or a cloth.
Loose Screws		Check for loose terminal block and connector screws and for other loose parts.	Tighten any loose screws or other loose parts.

16.2.3 Guidelines for Part Replacement

The following electric or electronic parts are subject to mechanical wear or deterioration over time. Use one of the following methods to check the standard replacement period.

- Use the service life prediction function of the SERVOPACK.
Refer to the following section for information on service life predictions.
→ [Chap. 10.5.1 'Monitoring Product Life' ...page 424](#)
- Use the following table.

Part	Standard Replacement Period	Remarks
Cooling Fan	4 to 5 years	The standard replacement periods given on the left are for the following operating conditions. <ul style="list-style-type: none"> ■ Surrounding air temperature: Annual average of 30°C ■ Load factor: 80% max. ■ Operation rate: 20 hours/day max.
Electrolytic Capacitor	10 years	
Relays	100,000 power ON operations	Power ON frequency: Once an hour
Battery	3 years without power supplied	Surrounding temperature without power supplied: 20°C

When any standard replacement period is close to expiring, contact your YASKAWA representative. After an examination of the part in question, we will determine whether the part should be replaced.



The parameters of any SERVOPACKs that are sent to YASKAWA for part replacement are reset to the factory settings before they are returned to you. Always keep a record of the parameter settings. And, always confirm that the parameters are properly set before starting operation.

16.2.4 Replacing the Battery

If the battery voltage drops to approximately 2.7 V or less, an A.830 alarm (Encoder Battery Alarm) or an A.930 warning (Encoder Battery Warning) will be displayed.

If this alarm or warning is displayed, the battery must be replaced.

Refer to the following section for the battery replacement procedure.

→ [Chap. 16.2.4 'Replacing the Battery' ...page 547](#)

Battery Alarm/Warning Selection

Whether to display an alarm or a warning is determined by the setting of Pn008 = n.□□□X (Low Battery Voltage Alarm/Warning Selection).

Parameter	Meaning	When Enabled	Classification
Pn008	n.□□□0 (default setting)	After restart	Setup
	n.□□□1		

- Pn008 = n.□□□0
 - The ALM (Servo Alarm) signal is output for up to five seconds when the control power supply is turned ON, and then the battery voltage is monitored for four seconds. No alarm will be displayed even if the battery voltage drops below the specified value after these four seconds.
- Pn008 = n.□□□1
 - The ALM (Servo Alarm) signal is output for up to five seconds when the control power supply is turned ON, and then the battery voltage is monitored continuously.

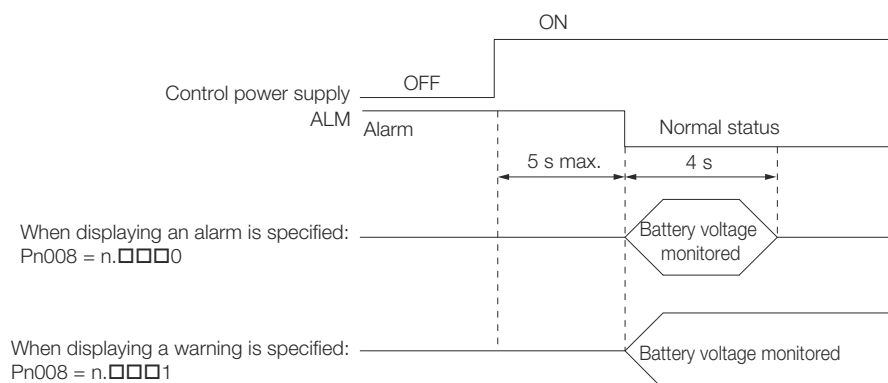


Fig. 375: Battery Alarm_Warning Selection

Battery Replacement Procedure

- When Installing a Battery on the Host Controller
 1. Turn ON only the control power supply to the SERVOPACK.
 2. Remove the old battery and mount a new battery.

3. Turn OFF the control power supply to the SERVOPACK to clear the A.830 alarm (Absolute Encoder Battery Error).
4. Turn ON the control power supply to the SERVOPACK again.
5. Make sure that the alarm has been cleared and that the SERVOPACK operates normally.

■ When Using an Encoder Cable with a Battery Case

1. Turn ON only the control power supply to the SERVOPACK.



If you remove the battery or disconnect the Encoder Cable while the control power supply to the SERVOPACK is OFF, the absolute encoder data will be lost.

2. Open the cover of the Battery Case.

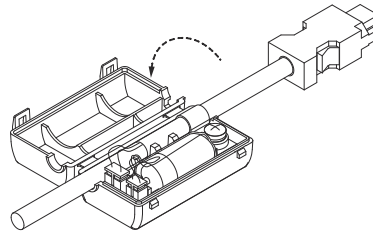


Fig. 376: Encoder Cable with a Battery Case - Open the Cover

3. Remove the old battery and mount a new battery.

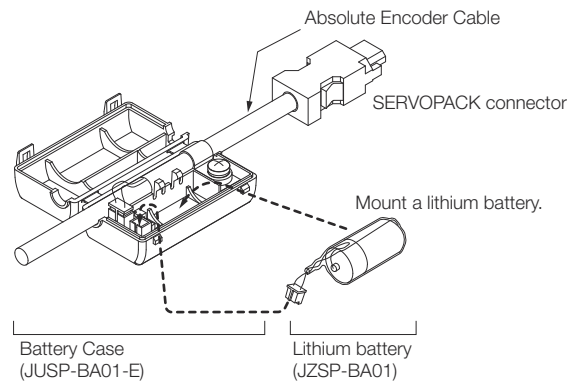


Fig. 377: Encoder Cable with a Battery Case - Mount a New Battery

4. Close the cover of the Battery Case.

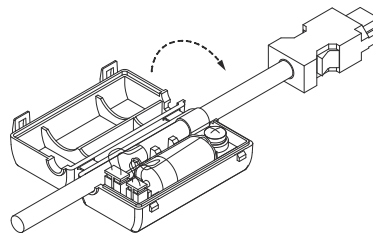


Fig. 378: Encoder Cable with a Battery Case - Close the Cover

5. Turn OFF the power supply to the SERVOPACK to clear the A.830 alarm (Absolute Encoder Battery Error).
6. Turn ON the power supply to the SERVOPACK.

7. → Make sure that the alarm has been cleared and that the SERVOPACK operates normally.

16.3 PROFINET Alarm Mechanism

16.3.1 General

PROFINET devices accomplish 99.9% of their communication via the cyclic, real-time communications channel. Data is produced according to a pre-defined format, and it's sent on a schedule that doesn't care if the data changes.

Alarms are really useful for the 0.1% of communication needs that can't be handled in that pre-defined cyclic format. They're event-driven, so a PROFINET device will only send them if an event happens that the PROFINET controller needs to know about.

16.3.2 PROFINET Alarm Structure

PROFINET Alarm Structure Alarms can encode data in two different ways, as either a *Diagnostic Alarm* or a *Process Alarm*. We're going to focus on **Diagnostic Alarms** in this section.

PROFINET defines diagnosis types of different detail to cover different use cases. The type of a diagnosis is associated with a 16 bit unsigned integer called **User Structure Identifier**. Here we consider diagnosis types with the USI 8000h (representing a **Channel Diagnosis**).

A Channel Diagnosis is made of a single 16 Bit Error Code called **Channel Error Type**. The Channel Error Type is characterizing the problem.

A PROFINET **Alarm Notification Protocol Data Unit (PDU)** is made of a generic diagnosis header followed by a variable number of diagnosis blocks. The header specifies the submodule associated with the diagnosis and the type of the diagnosis blocks.

When a fault or alarm situation occurs in the drive, the PROFINET communication interface will send an alarm notification (structure see table below), which the master station has to acknowledge.

Alarm Notification Structure

Attribute	Description
BlockHeader	-
AlarmType	Diagnosis <ul style="list-style-type: none"> ■ appears ■ disappears ■ disappears but other remain
API	3A00h (PROFIdrive profile)
SlotNumber	Slot number of the Drive Object (DO)
SubslotNumber	Sub-slot number of the sub-slot to which the diagnosis object is related
ModuleIdentNumber	Module Ident number of the DO
SubmoduleIdentNumber	FFFFh
AlarmSpecifier	Diagnosis type
UserStructureIdentifier	8000h (Channel Diagnosis Data)
ChannelNumber	8000h (Diagnosis refers to the Submodule itself)
ChannelProperties.Type	0
ChannelProperties.Reserved	0

Attribute	Description
ChannelProperties.Maintenance	Fault (PROFIdrive fault buffer) = Diagnosis <ul style="list-style-type: none"> MaintenanceDemanded = false MaintenanceRequired = false Warning (PROFIdrive warning mechanism) = Maintenance Demanded <ul style="list-style-type: none"> MaintenanceDemanded = true MaintenanceRequired = false
ChannelProperties.Specifier	01h = appears 02h = disappears 03h = disappears but other remain
ChannelProperties.Direction	0
ChannelProperties.Type	0
ChannelErrorType	Error code of drive fault or drive warning, ↪ Chap. 16.4.2.1 'List of Alarms' ...page 552 ↪ Chap. 16.5.2.1 'List of Warnings' ...page 601

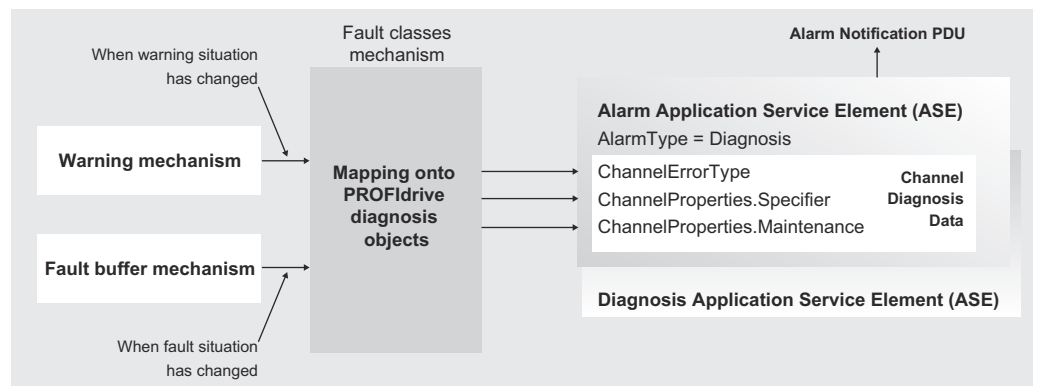


Fig. 379: Channel Diagnosis Data

Fault buffer mechanism	Warning mechanism	ChannelProperties.Specifier	ChannelProperties.Maintenance
Fault	Warning		
coming	-	appears (0x01)	Diagnosis
going	-	disappears (0x02)	Diagnosis
0	coming	appears (0x01)	MaintenanceDemanded
0	going	disappears (0x02)	MaintenanceDemanded

16.3.3 Fault Buffer Mechanism

The PROFIdrive profile provides a fault buffer that can store eight fault situations to PROFIdrive parameters. A fault situation, which may be associated with one or several fault messages, generates a device-specific fault reaction.

The fault buffer contains the fault messages which have been generated during the fault situation; the fault number list contains explanations and assignments to the various fault messages defined in the device.

The fault messages are entered into the fault buffer in the sequence in which they are detected. This means that each line in the fault buffer represents a fault message; the fault number of a fault message may be addressed in the particular parameter using the same subindex.

The error must be acknowledged after eliminating the cause. After resetting an error, this error is moved from the actual situation memory (PNU 947 sub indices 0-7) to the "fault situation n-1". This allows subsequent tracking of the faults. The PNU 944 (fault message counter) increments each time the fault buffer changes.



The PROFINET Fault Buffer (PNU 947) is volatile.

PNU 947			
	Fault number		Sub-index
Actual fault situation n	1C90		0
	1D00		1
	xxxx		2
			3
			4
			5
			6
			7
Fault situation n - 1	1A20		8
	1410		9
	yyyy		10
			11
			12
			13
			14
			15
Fault situation n - 7			56
			57
			58
			59
			60
			61
			62
			63

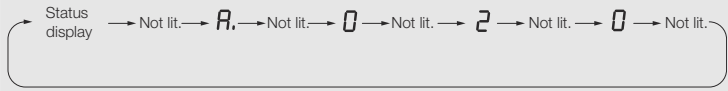
max. 8 x 8 entries,
last unacknowledged fault situation = n

Fig. 380: Fault buffer mechanism

16.4 Alarm Displays

16.4.1 Overview

To check an alarm that occurs in the SERVOPACK, use one of the following methods.

Panel display on SERVOPACK	<p>If there is an alarm, the code will be displayed one character at a time, as shown below.</p> <p>Example: Alarm A.020</p> 
SigmaWin+ Servo Information Display	<p>The alarm code will be displayed.</p> <p>Example: Alarm A.020</p>
Digital Operator	<p>The alarm code will be displayed.</p> <p>Example: Alarm A.020</p>
Statusword (6041h)	<p>Bit 3 (fault) in the statusword will change to 1. (Bit 3 is 0 during normal operation.)</p>
Error Code (603Fh)	<p>A current alarm code is stored in object error code (603Fh).</p> <p>Example: 1A20h</p>
Emergency message	<p>The IO-Controller is notified of any alarm that occurs. (Notification may not be possible if PROFINET communications are unstable.)</p> <p>Example: 1A20h</p>



However, if □□-□□ appears on the panel display, the display will indicate a SERVOPACK communications error. Replace the SERVOPACK.

The next section provides a list of the alarms that may occur and the causes of and corrections for those alarms.

16.4.2 List of Alarms

16.4.2.1 Overview



- The object Error Code (603Fh) provides the error code of the last alarm/warning which occurred in the drive device. The value of object Error Code (603Fh) is not reset until the alarm/warning has been acknowledged and no alarm or warning is present.
- PROFINET Fault Buffer (PNU 947) is volatile.

16.4.2.2 List of the PROFINET Module Alarms

The following alarm table gives the alarm name, alarm meaning, alarm stopping method, and alarm reset possibility in order of the alarm codes.

Servomotor Stopping Method for PROFINET Alarms

When a PROFINET alarm occurs, the Servomotor will stop according to the setting of object Fault Reaction Option Code (605Eh). The default setting is to 2, i.e. to slow down on quick stop ramp and turn the servo off. Refer to the following section for details.

➔ 'Fault Reaction Option Code' ...page 519

Alarm Reset Possibility

Yes: You can use an alarm reset to clear the alarm. However, this assumes that the cause of the alarm has been removed.

No: You cannot clear the alarm.

Alarm Code	Alarm Name	Alarm Meaning	Servomotor Stopping Method	Alarm Reset Possible?
A.A12 (1A12h)	Abnormal Communication Transition	Abnormal communication transition to Link Down or Controller in Stop mode during Operation Enable state.	Fault Reaction Option Code (6085h)	Yes
A.A20 (1A20h)	Parameter Setting Error	The parameter setting is out of range. In power up when non volatile parameter values exceed the current Motor Max values.	Fault Reaction Option Code (6085h)	Yes
A.A40 (1A40h)	System Initialization Error	The system initialization at power on sequence has failed.	Fault Reaction Option Code (6085h)	No
A.A41 (1A41h)	Communications Device Initialization Error	The communications initialization at power on sequence has failed.	Fault Reaction Option Code (6085h)	No
A.A42 (1A42h)	System Runtime Error	Flash load/Store execution failed	Fault Reaction Option Code (6085h)	No
A.A47 (1A47h)	Parameter Loading Error	The loading of SERVOPACK information has failed	Fault Reaction Option Code (6085h)	No
A.A48 (1A48h)	Read / Write EEPROM Error		Fault Reaction Option Code (6085h)	No
A.A4F (1A4Fh)	PROFINET Fatal Error	Option card resource or configuration problem	Fault Reaction Option Code (6085h)	No
A.AA9 (1AA9h)	Abnormal Control State	Main power is turned off during one of the following states: <ul style="list-style-type: none"> ■ S4: Operation ■ S3: Switched On ■ S51: Switching Off: ramp stop ■ S52: Switching Off: quick stop 	Dynamic Brake	Yes
		STW1.10 (controlled by PLC) = FALSE during Enable Operation state	Fault Reaction Option Code (6085h)	
A.AAB (1AABh)	Impermissible Traversing Block Data	Impermissible traversing block data	Fault Reaction Option Code (6085h)	Yes
A.AEF (1AEFh)	Driver Reset Interruption	This alarm occurs on every commanded Drive Reset.	Disables the drive	Yes
A.EA0 (1EA0h)	Command-Option IF Servo Unit Initial Error	Communications could not be initialized between the SERVOPACK and PROFINET Network Module within 10 seconds.	Gr.1	No
A.EA1 (1EA1h)	Command-Option IF Memory Check Error	An error occurred in communications memory between the SERVOPACK and PROFINET Network Module.	Gr.1	No
A.EA2 (1EA2h)	Command-Option IF Servo Synchronization Error	An error occurred in communications memory between the SERVOPACK and PROFINET Network Module.	Gr.1	Yes

Alarm Code	Alarm Name	Alarm Meaning	Servomotor Stopping Method	Alarm Reset Possible?
A.EA3 (1EA3h)	Command-Option IF Servo Data Error	An error occurred in communications memory between the SERVOPACK and PROFINET Network Module.	Gr.1	Yes

16.4.2.3 List of the SERVOPACK Alarms

The following alarm table gives the alarm name, alarm meaning, alarm stopping method, and alarm reset possibility in order of the alarm codes.

Servomotor Stopping Method for Alarms

Refer to the following section for information on the stopping method for alarms.

→ [Chap. 6.13.3 'Servomotor Stopping Method for Alarms' ...page 168](#)

Alarm Reset Possibility

Yes: You can use an alarm reset to clear the alarm. However, this assumes that the cause of the alarm has been removed.

No: You cannot clear the alarm.

List of Alarms

Alarm Code	Alarm Name	Alarm Meaning	Servomotor Stopping Method	Alarm Reset Possible?
A.020 (1020h)	Parameter Checksum Error	There is an error in the parameter data in the SERVOPACK.	Gr.1	No
A.021 (1021h)	Parameter Format Error	There is an error in the parameter data format in the SERVOPACK.	Gr.1	No
A.022 (1022h)	System Checksum Error	There is an error in the parameter data in the SERVOPACK.	Gr.1	No
A.024 (1024h)	System Alarm	An internal program error occurred in the SERVOPACK.	Gr.1	No
A.025 (1025h)	System Alarm	An internal program error occurred in the SERVOPACK.	Gr.1	No
A.030 (1030h)	Main Circuit Detector Error	There is an error in the detection data for the main circuit.	Gr.1	Yes
A.040 (1040h)	Parameter Setting Error	A parameter setting is outside of the setting range.	Gr.1	No
A.041 (1041h)	Encoder Output Pulse Setting Error	The setting of Pn212 (Encoder Output Pulses) or Pn281 (Encoder Output Resolution) is outside of the setting range or does not satisfy the setting conditions.	Gr.1	No
A.042 (1042h)	Parameter Combination Error	The combination of some parameters exceeds the setting range.	Gr.1	No
A.044 (1044h)	Semi-Closed/Fully-Closed Loop Control Parameter Setting Error	The settings of the Option Module and Pn002 = n.X□□□ (External Encoder Usage) do not match.	Gr.1	No
A.050 (1050h)	Combination Error	The capacities of the SERVOPACK and Servomotor do not match.	Gr.1	Yes
A.051 (1051h)	Unsupported Device Alarm	An unsupported device was connected.	Gr.1	No

Alarm Code	Alarm Name	Alarm Meaning	Servomotor Stopping Method	Alarm Reset Possible?
A.070 (1070h)	Motor Type Change Detected	The connected motor is a different type of motor from the previously connected motor.	Gr.1	No
A.080 (1080h)	Linear Encoder Pitch Setting Error	The setting of Pn282 (Linear Encoder Pitch) has not been changed from the default setting.	Gr.1	No
A.0b0 (10b0h)	Invalid Servo ON Command Alarm	The Servo ON command (Enable Operation command) was sent from the host controller after a utility function that turns ON the Servomotor was executed.	Gr.1	Yes
A.100 (1100h)	Overcurrent Detected	An overcurrent flowed through the power transistor or the heat sink overheated.	Gr.1	No
A.101 (1101h)	Motor Overcurrent Detected	The current to the motor exceeded the allowable current.	Gr.1	No
A.300 (1300h)	Regeneration Error	There is an error related to regeneration.	Gr.1	Yes
A.320 (1320h)	Regenerative Overload	A regenerative overload occurred.	Gr.2	Yes
A.330 (1330h)	Main Circuit Power Supply Wiring Error	<ul style="list-style-type: none"> ■ The AC power supply input setting or DC power supply input setting is not correct. ■ The power supply wiring is not correct. 	Gr.1	Yes
A.400 (1400h)	Overvoltage	The main circuit DC voltage is too high.	Gr.1	Yes
A.410 (1410h)	Undervoltage	The main circuit DC voltage is too low.	Gr.2	Yes
A.510 (1510h)	Overspeed	The motor exceeded the maximum speed.	Gr.1	Yes
A.511 (1511h)	Encoder Output Pulse Overspeed	<ul style="list-style-type: none"> ■ Rotary Servomotor: The pulse output speed for the setting of Pn212 (Encoder Output Pulses) was exceeded. ■ Linear Servomotor: The motor speed upper limit for the setting of Pn281 (Encoder Output Resolution) was exceeded. 	Gr.1	Yes
A.520 (1520h)	Vibration Alarm	Abnormal oscillation was detected in the motor speed.	Gr.1	Yes
A.521 (1521h)	Autotuning Alarm	Vibration was detected during autotuning for the tuning-less function.	Gr.1	Yes
A.550 (1550h)	Maximum Speed Setting Error	The setting of Pn385 (Maximum Motor Speed) is greater than the maximum motor speed.	Gr.1	Yes
A.710 (1710h)	Instantaneous Overload	The Servomotor was operating for several seconds to several tens of seconds under a torque that largely exceeded the rating.	Gr.2	Yes

Alarm Code	Alarm Name	Alarm Meaning	Servomotor Stopping Method	Alarm Reset Possible?
A.720 (1720h)	Continuous Overload	The Servomotor was operating continuously under a torque that exceeded the rating.	Gr.1	Yes
A.730 (1730h)	Dynamic Brake Overload	When the dynamic brake was applied, the rotational or linear kinetic energy exceeded the capacity of the Dynamic Brake Resistor.	Gr.1	Yes
A.731 (1731h)				
A.740 (1740h)	Inrush Current Limiting Resistor Overload	The main circuit power supply was frequently turned ON and OFF.	Gr.2	Yes
A.7A1 (17A1h)	Internal Temperature Error 1 (Control Board Temperature Error)	The surrounding temperature of the control PCB is abnormal.	Gr.2	Yes
A.7A2 (17A2h)	Internal Temperature Error 2 (Power Board Temperature Error)	The surrounding temperature of the power PCB is abnormal.	Gr.2	Yes
A.7A3 (17A3h)	Internal Temperature Sensor Error	An error occurred in the temperature sensor circuit.	Gr.2	No
A.7Ab (17Abh)	SERVOPACK Built-in Fan Stopped	The fan inside the SERVOPACK stopped.	Gr.1	Yes
A.810 (1810h)	Encoder Backup Alarm	The power supplies to the encoder all failed and the position data was lost.	Gr.1	No
A.820 (1820h)	Encoder Checksum Alarm	There is an error in the checksum results for encoder memory.	Gr.1	No
A.830 (1830h)	Encoder Battery Alarm	The battery voltage was lower than the specified level after the control power supply was turned ON.	Gr.1	Yes
A.840 (1840h)	Encoder Data Alarm	There is an internal data error in the encoder.	Gr.1	No
A.850 (1850h)	Encoder Overspeed	The encoder was operating at high speed when the power was turned ON.	Gr.1	No
A.860 (1860h)	Encoder Overheated	The internal temperature of encoder is too high.	Gr.1	No
A.861 (1861h)	Motor Overheated	The internal temperature of motor is too high.	Gr.1	No
A.862 (1862h)	Overheat Alarm	The input voltage (temperature) for the overheat protection input (TH) signal exceeded the setting of Pn61B (Overheat Alarm Level).	Gr.1	Yes
A.890 (1890h)	Encoder Scale Error	A failure occurred in the linear encoder.	Gr.1	No
A.891 (1891h)	Encoder Module Error	An error occurred in the linear encoder.	Gr.1	No
A.8A0 (18A0h)	External Encoder Error	An error occurred in the external encoder.	Gr.1	Yes
A.8A1 (18A1h)	External Encoder Module Error	An error occurred in the Serial Converter Unit.	Gr.1	Yes

Alarm Code	Alarm Name	Alarm Meaning	Servomotor Stopping Method	Alarm Reset Possible?
A.8A2 (18A2h)	External Incremental Encoder Sensor Error	An error occurred in the external encoder.	Gr.1	Yes
A.8A3 (18A3h)	External Absolute Encoder Position Error	An error occurred in the position data of the external encoder.	Gr.1	Yes
A.8A5 (18A5h)	External Encoder Over-speed	An overspeed error occurred in the external encoder.	Gr.1	Yes
A.8A6 (18A6h)	External Encoder Over-heated	An overheating error occurred in the external encoder.	Gr.1	Yes
A.b33 (1b33h)	Current Detection Error 3	An error occurred in the current detection circuit.	Gr.1	No
A.bF0 (1bF0h)	System Alarm 0	Internal program error 0 occurred in the SERVOPACK.	Gr.1	No
A.bF1 (1bF1h)	System Alarm 1	Internal program error 1 occurred in the SERVOPACK.	Gr.1	No
A.bF2 (1bF2h)	System Alarm 2	Internal program error 2 occurred in the SERVOPACK.	Gr.1	No
A.bF3 (1bF3h)	System Alarm 3	Internal program error 3 occurred in the SERVOPACK.	Gr.1	No
A.bF4 (1bF4h)	System Alarm 4	Internal program error 4 occurred in the SERVOPACK.	Gr.1	No
A.bF5 (1bF5h)	System Alarm 5	Internal program error 5 occurred in the SERVOPACK.	Gr.1	No
A.bF6 (1bF6h)	System Alarm 6	Internal program error 6 occurred in the SERVOPACK.	Gr.1	No
A.bF7 (1bF7h)	System Alarm 7	Internal program error 7 occurred in the SERVOPACK.	Gr.1	No
A.bF8 (1bF8h)	System Alarm 8	Internal program error 8 occurred in the SERVOPACK.	Gr.1	No
A.C10 (1C10h)	Servomotor Out of Control	The Servomotor ran out of control.	Gr.1	Yes
A.C20 (1C20h)	Phase Detection Error	The detection of the phase is not correct.	Gr.1	No
A.C21 (1C21h)	Polarity Sensor Error	An error occurred in the polarity sensor.	Gr.1	No
A.C22 (1C22h)	Phase Information Disagreement	The phase information does not match.	Gr.1	No
A.C50 (1C50h)	Polarity Detection Failure	The polarity detection failed.	Gr.1	No
A.C51 (1C51h)	Overtravel Detected during Polarity Detection	The overtravel signal was detected during polarity detection.	Gr.1	Yes
A.C52 (1C52h)	Polarity Detection Not Completed	The servo was turned ON before the polarity was detected.	Gr.1	Yes
A.C53 (1C53h)	Out of Range of Motion for Polarity Detection	The travel distance exceeded the setting of Pn48E (Polarity Detection Range).	Gr.1	No
A.C54 (1C54h)	Polarity Detection Failure 2	The polarity detection failed.	Gr.1	No

Alarm Code	Alarm Name	Alarm Meaning	Servomotor Stopping Method	Alarm Reset Possible?
A.C80 (1C80h)	Encoder Clear Error or Multiturn Limit Setting Error	The multiturn data for the absolute encoder was not correctly cleared or set.	Gr.1	No
A.C90 (1C90h)	Encoder Communications Error	Communications between the encoder and SERVOPACK is not possible.	Gr.1	No
A.C91 (1C91h)	Encoder Communications Position Data Acceleration Rate Error	An error occurred in calculating the position data of the encoder.	Gr.1	No
A.C92 (1C92h)	Encoder Communications Timer Error	An error occurred in the communications timer between the encoder and SERVOPACK.	Gr.1	No
A.CA0 (1CA0h)	Encoder Parameter Error	The parameters in the encoder are corrupted.	Gr.1	No
A.Cb0 (1Cb0h)	Encoder Echoback Error	The contents of communications with the encoder are incorrect.	Gr.1	No
A.CC0 (1CC0h)	Multiturn Limit Disagreement	Different multiturn limits have been set in the encoder and the SERVOPACK.	Gr.1	No
A.CF1 (1CF1h)	Reception Failed Error in Feedback Option Module Communications	Receiving data from the Feedback Option Module failed.	Gr.1	No
A.CF2 (1CF2h)	Timer Stopped Error in Feedback Option Module Communications	An error occurred in the timer for communications with the Feedback Option Module.	Gr.1	No
A.d00 (1d00h)	Position Deviation Overflow	The setting of Pn520 (Excessive Position Deviation Alarm Level) was exceeded by the position deviation while the servo was ON.	Gr.1	Yes
A.d01 (1d01h)	Position Deviation Overflow Alarm at Servo ON	The servo was turned ON after the position deviation exceeded the setting of Pn526 (Excessive Position Deviation Alarm Level at Servo ON) while the servo was OFF.	Gr.1	Yes
A.d02 (1d02h)	Position Deviation Overflow Alarm for Speed Limit at Servo ON	If position deviation remains in the deviation counter, the setting of Pn529 or Pn584 (Speed Limit Level at Servo ON) limits the speed when the servo is turned ON. This alarm occurs if a position reference is input and the setting of Pn520 (Excessive Position Deviation Alarm Level) is exceeded before the limit is cleared.	Gr.2	Yes
A.d10 (1d10h)	Motor-Load Position Deviation Overflow	There was too much position deviation between the motor and load during fully-closed loop control.	Gr.2	Yes
A.d30 (1d30h)	Position Data Overflow	The position feedback data exceeded $\pm 1,879,048,192$.	Gr.1	No
A.E00 (1E00h)	PROFINET Module Interface Initialization Timeout Error	Communications initialization failed between the SERVOPACK and the PROFINET Module.	Gr.2	Yes

Alarm Code	Alarm Name	Alarm Meaning	Servomotor Stopping Method	Alarm Reset Possible?
A.E02 (1E02h)	PROFINET Internal Synchronization Error 1	A synchronization error occurred during PROFINET communications with the SERVOPACK.	Gr.1	Yes
A.E03 (1E03h)	PROFINET Module Interface Communications Data Error	There is an error in the communications data between the SERVOPACK and the PROFINET Module.	Gr.1	Yes
A.E71 (1E71h)	Safety Option Module Detection Failure	Detection of the Safety Option Module failed.	Gr.1	No
A.E72 (1E72h)	Feedback Option Module Detection Failure	Detection of the Feedback Option Module failed.	Gr.1	No
A.E74 (1E74h)	Unsupported Safety Option Module Alarm	An unsupported Safety Option Module was connected.	Gr.1	No
A.E75 (1E75h)*1	Unsupported Feedback Option Module Alarm	An unsupported Feedback Option Module was connected.	Gr.1	No
A.Eb1 (1Eb1h)	Safety Function Signal Input Timing Error	An error occurred in the input timing of the safety function signal.	Gr.1	No
A.Ed1 (1Ed1h)	Command Execution Timeout	A timeout error occurred for a PROFINET command.	Gr.2	Yes
A.F10 (1F10h)	Power Supply Line Open Phase	The voltage was low for more than one second for phase R, S, or T when the main power supply was ON.	Gr.2	Yes
FL-1*2	System Alarm	An internal program error occurred in the SERVOPACK.	-	No
FL-2*2				
FL-3*2				
FL-4*2				
FL-5*2				
FL-6*2				
CPF00	Digital Operator Communications Error 1	Communications were not possible between the Digital Operator (model: JUSP-OP05A-1-E) and the SERVOPACK (e.g., a CPU error occurred).	-	No
CPF01	Digital Operator Communications Error 2			

*1. This alarm can occur when a Fully-closed Option Module is mounted.

*2. These alarms are not stored in the alarm history. They are only displayed on the panel display.



The Eb0h, Eb2h to Eb9h, and EC0h to EC2h alarms can occur when a Safety Module is connected. Refer to the following manual for details.

AC Servo Drive Σ -V-Series/ Σ -V-Series for Large-Capacity Models/ Σ -7-Series User's Manual Safety Module (Manual No.: SIEP C720829 06)

16.4.3 Troubleshooting Alarms

16.4.3.1 Overview

The causes of and corrections for the alarms are given in the following tables. Contact your YASKAWA representative if you cannot solve a problem with the correction given in the tables.

16.4.3.2 Troubleshooting of the PROFINET Module Alarms

Alarm Code	Alarm Name	Possible Cause	Confirmation	Correction
A.A12 (1A12h)	Abnormal Communication Transition	IO-Controller in STOP mode during PROFIdrive state "S4: Operation".	Check the cause why the IO-Controller changed to STOP mode.	Change IO-Controller to RUN mode and send command fault acknowledge.
		PROFINET communication link down during PROFIdrive state "S4: Operation" as a results of cable or wiring disconnection.	Check the PROFINET cable and connector wiring.	Correct the wiring and send command fault acknowledge.
		Application Relation (AR) with the IO-Controller is aborted during PROFIdrive state "S4: Operation" (e.g. IO-Controller closed the connection, etc.).	Check possible reasons for Application Relation (AR) abort.	Re-establish connection with IO-Controller and send command fault acknowledge.
A.A20 (1A20h)	Parameter Setting Error	The parameter settings are out of range during power-on.	Check the parameter settings. Verify that the non-volatile parameter values do not exceed the current Motor Max. values.	"Initialize the parameter settings (load device parameter set (PNU 976)) and cycle power." Correct the parameter settings and store them non-volatile (transfer in non-volatile memory (PNU 977)).
			Check the wiring of the encoder.	Turn power supply OFF, correct the encoder connection and turn power supply ON.
A.A40 (1A40h)	System Initialization Error	The system initialization at power-on sequence failed.	-	Replace the PROFINET SERVOPACK module.
A.A41 (1A41h)	Communications Device Initialization Error	A failure occurred in the PROFINET SERVOPACK module.	-	Replace the PROFINET SERVOPACK module.
A.A42 (1A42h)	System Runtime Error	The flash load/store execution failed.	-	Cycle power.
			-	If after several power cycles the problem still exists, replace the PROFINET SERVOPACK module.
A.A47 (1A47h)	Parameter Loading Error	The loading of SERVOPACK information failed.	Check the parameter settings.	Correct the parameter settings and cycle power.

Alarm Code	Alarm Name	Possible Cause	Confirmation	Correction
		The power supply was turned ON while the encoder was not connected.	Check the wiring of the encoder.	Turn power supply OFF, correct the encoder connection and turn power supply ON.
		A failure occurred in the PROFINET SERVOPACK module.	-	Replace the PROFINET SERVOPACK module.
A.A48 (1A48h)	Read / Write EEPROM Error	The power supply was turned OFF while writing the parameter settings.	Check the timing of shutting OFF the power supply.	Initialize the parameter settings (load device parameter set (PNU 976)) and then set the parameters again.
		The number of times that parameters were written exceeded the limit.	-	Replace the PROFINET SERVOPACK module. Reconsider the method for writing the parameters.
		The power supply voltage suddenly dropped.	Measure the power supply voltage.	"Set the power supply voltage within the specified range, and initialize the parameter settings (load device parameter set (PNU 976))."
		A failure occurred in the PROFINET SERVOPACK module.	-	Replace the PROFINET SERVOPACK module.
A.A4F (1A4Fh)	PROFINET Fatal Error	Option card resource or configuration problem.	Check IO-Controller configuration.	Cycle power.
			-	If after several power cycles the problem still exists, replace the PROFINET SERVOPACK module.
A.AA9 (1AA9h)	Abnormal Control State	Main power turned off during PRO-Fl drive states "S3: Switched On", "S4: Operation", or "S5: Switching Off".	Check if main power was turned off while drive was not in PRO-Fl drive states "S1: Switching On Inhibited" or "S2: Ready For Switching On".	Supply main power and send command fault acknowledge.
		Bit "Control By PLC" (STW1 bit 10) not set during state "S4: Operation".	Check bit "Control By PLC" (STW1 bit 10) was reset by application / PLC during state "S4: Operation".	Set bit "Control By PLC" (STW1 bit 10) and send command fault acknowledge.
A.AAB (1AABh)	Impermissible Traversing Block Data	Values of the Traversing Block profile to activate are outside valid range.	Check if the Traversing Block (TB) profile (Traversing Block Task Mode, TB Profile Velocity, TB Profile Acc., TB Profile Dec.) is in valid range.	Correct the values of Traversing Block profile, send command fault acknowledge and activate Traversing Block profile again.

Alarm Code	Alarm Name	Possible Cause	Confirmation	Correction
A.AEF (1AEFh)	Driver Reset Interruption	Drive Reset (PNU 972) command was sent.	-	-
A.EA0 (1EA0h)	Command-Option IF Servo Unit Initial Error	A failure occurred in the PROFINET SERVOPACK module.	Check the SERVO-PACK and its connections.	Cycle power.
			-	Replace the PROFINET SERVO-PACK module.
A.EA1 (1EA1h)	Command-Option IF Memory Check Error	A failure occurred in the PROFINET SERVOPACK module.	Check the SERVO-PACK and its connections.	Cycle power.
			-	Replace the PROFINET SERVO-PACK module.
A.EA2 (1EA2h)	Command-Option IF Servo Synchronization Error	A failure occurred in the PROFINET SERVOPACK module.	Check the SERVO-PACK and its connections.	Cycle power.
			-	Replace the PROFINET SERVO-PACK module.
A.EA3 (1EA3h)	Command-Option IF Servo Data Error	Noise caused an error in communications in the SERVOPACK.	-	Implement countermeasures against noise.
			Check the SERVO-PACK and its connections.	Cycle power.
		A failure occurred in the PROFINET SERVOPACK module.	-	Replace the PROFINET SERVO-PACK module.

16.4.3.3 Troubleshooting of the SERVOPACK Alarms

The causes of and corrections for the alarms are given in the following table. Contact your YASKAWA representative if you cannot solve a problem with the correction given in the table.

Alarm Code	Alarm Name	Possible Cause	Confirmation	Correction	Reference
A.020 (1020h)	Parameter Checksum Error (There is an error in the parameter data in the SERVO-PACK.)	The power supply voltage suddenly dropped.	Measure the power supply voltage.	Set the power supply voltage within the specified range, and initialize the parameter settings.	→ Chap. 6.2.6 'Initializing SERVOPACK Parameter Settings' ...page 136
		The power supply was shut OFF while writing parameter settings.	Check the timing of shutting OFF the power supply.	Initialize the parameter settings and then set the parameters again.	
		The number of times that parameters were written exceeded the limit.	Check to see if the parameters were frequently changed from the host controller.	The SERVOPACK may be faulty. Replace the SERVO-PACK. Reconsider the method for writing the parameters.	-

Alarm Code	Alarm Name	Possible Cause	Confirmation	Correction	Reference
		A malfunction was caused by noise from the AC power supply, ground, static electricity, or other source.	Turn the power supply to the SERVOPACK OFF and ON again. If the alarm still occurs, noise may be the cause.	Implement countermeasures against noise.	→ Chap. 5.2.2 'Countermeasures against Noise' ...page 86
		Gas, water drops, or cutting oil entered the SERVOPACK and caused failure of the internal components.	Check the installation conditions.	The SERVOPACK may be faulty. Replace the SERVOPACK.	–
		A failure occurred in the SERVOPACK.	Turn the power supply to the SERVOPACK OFF and ON again. If the alarm still occurs, the SERVOPACK may have failed.	The SERVOPACK may be faulty. Replace the SERVOPACK.	–
A.021 (1021h)	Parameter Format Error (There is an error in the parameter data format in the SERVOPACK.)	The software version of the SERVOPACK that caused the alarm is older than the software version of the parameters specified to write.	Read the product information to see if the software versions are the same. If they are different, it could be the cause of the alarm.	Write the parameters from another SERVOPACK with the same model and the same software version, and then turn the power OFF and ON again.	→ Chap. 10.2.1 'Monitoring Product Information' ...page 410
		A failure occurred in the SERVOPACK.	–	The SERVOPACK may be faulty. Replace the SERVOPACK.	–
A.022 (1022h)	System Checksum Error (There is an error in the parameter data in the SERVOPACK.)	The power supply voltage suddenly dropped.	Measure the power supply voltage.	The SERVOPACK may be faulty. Replace the SERVOPACK.	–
		The power supply was shut OFF while setting a utility function.	Check the timing of shutting OFF the power supply.	The SERVOPACK may be faulty. Replace the SERVOPACK.	–
		A failure occurred in the SERVOPACK.	Turn the power supply to the SERVOPACK OFF and ON again. If the alarm still occurs, the SERVOPACK may have failed.	The SERVOPACK may be faulty. Replace the SERVOPACK.	–
A.024 (1024h)	System Alarm (An internal program error occurred in the SERVOPACK.)	A failure occurred in the SERVOPACK.	–	The SERVOPACK may be faulty. Replace the SERVOPACK.	–
A.025 (1025h)	System Alarm (An internal program error occurred in the SERVOPACK.)	A failure occurred in the SERVOPACK.	–	The SERVOPACK may be faulty. Replace the SERVOPACK.	–

Alarm Code	Alarm Name	Possible Cause	Confirmation	Correction	Reference
A.030 (1030h)	Main Circuit Detector Error	A failure occurred in the SERVOPACK.	–	The SERVOPACK may be faulty. Replace the SERVOPACK.	–
A.040 (1040h)	Parameter Setting Error (A parameter setting is outside of the setting range.)	The SERVOPACK and Servomotor capacities do not match each other.	Check the combination of the SERVOPACK and Servomotor capacities.	Select a proper combination of SERVOPACK and Servomotor capacities.	→ Chap. 2.7.1 'Combinations of SERVOPACKs and Servomotors' ...page 49
		The motor parameter file was not written to the linear encoder. (This applies only when not using a Serial Converter Unit.)	Check to see if the motor parameter file was written to the linear encoder.	Write the motor parameter file to the linear encoder.	→ Chap. 6.7 'Writing Linear Servomotor Parameters' ...page 143
		A failure occurred in the SERVOPACK.	–	The SERVOPACK may be faulty. Replace the SERVOPACK.	–
		A parameter setting is outside of the setting range.	Check the setting ranges of the parameters that have been changed.	Set the parameters to values within the setting ranges.	–
A.041 (1041h)	Encoder Output Pulse Setting Error	The setting of Pn212 (Encoder Output Pulses) or Pn281 (Encoder Output Resolution) is outside of the setting range or does not satisfy the setting conditions.	Check the setting of Pn212 or Pn281.	Set Pn212 or Pn281 to an appropriate value.	→ Chap. 7.6.3 'Setting for the Encoder Divided Pulse Output' ...page 210
A.042 (1042h)	Parameter Combination Error	The speed of program jogging went below the setting range when Pn533 or Pn585 (Program Jogging Speed) was changed.	Check to see if the detection conditions*1 are satisfied.	Increase the setting of Pn533 or Pn585.	→ Chap. 8.7.1 'Convenient Function to Use during Trial Operation' ...page 264
A.044 (1044h)	Semi-Closed/ Fully-Closed Loop Control Parameter Setting Error	The setting of the Fully-closed Module does not match the setting of Pn002 = n.X□□□ (External Encoder Usage).	Check the setting of Pn002 = n.X□□□.	Make sure that the setting of the Fully-closed Module agrees with the setting of Pn002 = n.X□□□.	→ Chap. 11.4.3 'Setting the Motor Direction and the Machine Movement Direction' ...page 433
A.050 (1050h)	Combination Error (The capacities of the SERVOPACK and Servomotor do not match.)	The SERVOPACK and Servomotor capacities do not match each other.	Confirm that the following condition is met: $1/4 \leq (\text{Servomotor capacity}/\text{SERVOPACK capacity}) \leq 4$	Select a proper combination of the SERVOPACK and Servomotor capacities.	→ Chap. 2.7.1 'Combinations of SERVOPACKs and Servomotors' ...page 49
		A failure occurred in the encoder.	Replace the encoder and check to see if the alarm still occurs.	Replace the Servomotor or encoder.	–

Alarm Code	Alarm Name	Possible Cause	Confirmation	Correction	Reference
		A failure occurred in the SERVOPACK.	–	The SERVOPACK may be faulty. Replace the SERVOPACK.	–
A.051 (1051h)	Unsupported Device Alarm	The motor parameter file was not written to the linear encoder. (This applies only when not using a Serial Converter Unit.)	Check to see if the motor parameter file was written to the linear encoder.	Write the motor parameter file to the linear encoder.	➔ Chap. 6.7 'Writing Linear Servomotor Parameters' ...page 143
		An unsupported Serial Converter Unit or encoder (e.g., an external encoder) is connected to the SERVOPACK.	Check the product combination specifications.	Change to a correct combination of models.	–
A.070 (1070h)	Motor Type Change Detected (The connected motor is a different type of motor from the previously connected motor.)	A Rotary Servomotor was removed and a Linear Servomotor was connected.	–	Set the parameters for a Linear Servomotor and reset the motor type alarm. Then, turn the power supply to the SERVOPACK OFF and ON again.	➔ Chap. 16.4.8 'Resetting Motor Type Alarms' ...page 599
		A Linear Servomotor was removed and a Rotary Servomotor was connected.	–	Set the parameters for a Rotary Servomotor and reset the motor type alarm. Then, turn the power supply to the SERVOPACK OFF and ON again.	➔ Chap. 16.4.8 'Resetting Motor Type Alarms' ...page 599
A.080 (1080h)	Linear Encoder Pitch Setting Error	The setting of Pn282 (Linear Encoder Pitch) has not been changed from the default setting.	Check the setting of Pn282.	Correct the setting of Pn282.	➔ Chap. 6.6 'Setting the Linear Encoder Pitch' ...page 142
A.0b0 (10b0h)	Invalid Servo ON Command Alarm	The Servo ON command (Enable Operation command) was sent from the host controller after a utility function that turns ON the Servomotor was executed.	–	Turn the power supply to the SERVOPACK OFF and ON again. Or, execute a software reset.	➔ Chap. 7.11.1 'Software Reset' ...page 233
A.100 (1100h)	Overcurrent Detected (An overcurrent flowed through the power transformer or the heat sink overheated.)	The Main Circuit Cable is not wired correctly or there is faulty contact.	Check the wiring.	Correct the wiring.	➔ Chap. 5.5.1 'Wiring Servomotors' ...page 105
		There is a short-circuit or ground fault in a Main Circuit Cable.	Check for short-circuits across Servomotor phases U, V, and W, or between the ground and Servomotor phases U, V, and W.	The cable may be shortcircuited. Replace the cable.	

Alarm Code	Alarm Name	Possible Cause	Confirmation	Correction	Reference
		There is a short-circuit or ground fault inside the Servomotor.	Check for short-circuits across Servomotor phases U, V, and W, or between the ground and Servomotor phases U, V, or W.	The Servomotor may be faulty. Replace the Servomotor.	
		There is a short-circuit or ground fault inside the SERVOPACK.	Check for short-circuits across the Servomotor connection terminals U, V, and W on the SERVOPACK, or between the ground and terminals U, V, or W.	The SERVOPACK may be faulty. Replace the SERVOPACK.	
		The Regenerative Resistor is not wired correctly or there is faulty contact.	Check the wiring.	Correct the wiring.	→ Chap. 5.4.6 'Wiring Regenerative Resistors' ...page 102
		The dynamic brake (DB, emergency stop executed from the SERVOPACK) was frequently activated, or a DB overload alarm occurred.	Check the power consumed by the DB resistor to see how frequently the DB is being used. Or, check the alarm display to see if a DB overload alarm (A.730 or A.731) has occurred.	Change the SERVOPACK model, operating methods, or the mechanisms so that the dynamic brake does not need to be used so frequently.	—
		The regenerative processing capacity was exceeded.	Check the regenerative load ratio in the SigmaWin+ Motion Monitor Tab Page to see how frequently the Regenerative Resistor is being used.	Recheck the operating conditions and load.	*2
		The SERVOPACK regenerative resistance is too small.	Check the regenerative load ratio in the SigmaWin+ Motion Monitor Tab Page to see how frequently the Regenerative Resistor is being used.	Change the regenerative resistance to a value larger than the SERVOPACK minimum allowable resistance.	—
		A heavy load was applied while the Servomotor was stopped or running at a low speed.	Check to see if the operating conditions exceed Servo Drive specifications.	Reduce the load applied to the Servomotor. Or, increase the operating speed.	—

Alarm Code	Alarm Name	Possible Cause	Confirmation	Correction	Reference	
		A malfunction was caused by noise.	Improve the noise environment, e.g. by improving the wiring or installation conditions, and check to see if the alarm still occurs.	Implement countermeasures against noise, such as correct wiring of the FG. Use an FG wire size equivalent to the SERVOPACK's main circuit wire size.	–	
		A failure occurred in the SERVOPACK.	–	Turn the power supply to the SERVOPACK OFF and ON again. If an alarm still occurs, the SERVOPACK may be faulty. Replace the SERVOPACK.	–	
A.101 (1101h)	Motor Overcurrent Detected (The current to the motor exceeded the allowable current.)	The Main Circuit Cable is not wired correctly or there is faulty contact.	Check the wiring.	Correct the wiring.	→ Chap. 5.5.1 'Wiring Servomotors' ...page 105	
		There is a short-circuit or ground fault in a Main Circuit Cable.	Check for short-circuits across cable phases U, V, and W, or between the ground and cable phases U, V, and W.	The cable may be shortcircuited. Replace the cable.		
		There is a short-circuit or ground fault inside the Servomotor.	Check for short-circuits across Servomotor phases U, V, and W, or between the ground and Servomotor phases U, V, or W.	The Servomotor may be faulty. Replace the Servomotor.		
		There is a short-circuit or ground fault inside the SERVOPACK.	Check for short-circuits across the Servomotor connection terminals U, V, and W on the SERVOPACK, or between the ground and terminals U, V, or W.	The SERVOPACK may be faulty. Replace the SERVOPACK.		
		A heavy load was applied while the Servomotor was stopped or running at a low speed.	Check to see if the operating conditions exceed Servo Drive specifications.	Reduce the load applied to the Servomotor. Or, increase the operating speed.		–
		A malfunction was caused by noise.	Improve the noise environment, e.g. by improving the wiring or installation conditions, and check to see if the alarm still occurs.	Implement countermeasures against noise, such as correct wiring of the FG. Use an FG wire size equivalent to the SERVOPACK's main circuit wire size.		–

Alarm Code	Alarm Name	Possible Cause	Confirmation	Correction	Reference
		A failure occurred in the SERVOPACK.	–	Turn the power supply to the SERVOPACK OFF and ON again. If an alarm still occurs, the SERVOPACK may be faulty. Replace the SERVOPACK.	–
A.300 (1300h)	Regeneration Error	When using the builtin regenerative resistor, the jumper between the regenerative resistor terminals (B2 and B3) was removed from one of the following SERVOPACKs: SGD7S-3R8A, -5R5A, -7R6A, -120A, -180A, -200A, or -330A.	Check to see if the jumper is connected between power supply terminals B2 and B3.*3	Correctly connect a jumper.	→ Chap. 5.4.6 'Wiring Regenerative Resistors' ...page 102
		The External Regenerative Resistor or Regenerative Resistor Unit is not wired correctly, or was removed or disconnected.	Check the wiring of the External Regenerative Resistor or Regenerative Resistor Unit.*3	Correct the wiring of the External Regenerative Resistor or Regenerative Resistor Unit.	
		Pn600 (Regenerative Resistor Capacity) is set to a value other than 0 (setting unit: 10 W) even though a Regenerative Resistor is not connected to one of the following SERVOPACKs: SGD7S-R70A, -R90A, -1R6A, -2R8A, -R70F, -R90F, -2R1F, or -2R8F.	Check to see if an External Regenerative Resistor is connected and check the setting of Pn600.	Connect an External Regenerative Resistor, or if a Regenerative Resistor is not required, set Pn600 to 0.	→ Chap. 6.18 'Setting the Regenerative Resistor Capacity' ...page 187
		A Regenerative Resistor is not connected to one of the following SERVOPACKs: SGD7S-470A, -550A, -590A, or -780A.	Check to see if an External Regenerative Resistor or a Regenerative Resistor Unit is connected and check the setting of Pn600 (Regenerative Resistor Capacity).	Connect an External Regenerative Resistor and set Pn600 to an appropriate value, or connect a Regenerative Resistor Unit and set Pn600 to 0 (setting unit: 10 W).	
		A failure occurred in the SERVOPACK.	–	While the main circuit power supply is OFF, turn the control power supply to the SERVOPACK OFF and ON again. If an alarm still occurs, the SERVOPACK may be faulty. Replace the SERVOPACK.	

Alarm Code	Alarm Name	Possible Cause	Confirmation	Correction	Reference
A.320 (1320h)	Regenerative Overload	The power supply voltage exceeded the specified range.	Measure the power supply voltage.	Set the power supply voltage within the specified range.	—
		The external regenerative resistance value or regenerative resistor capacity is too small, or there has been a continuous regeneration state.	Check the operating conditions or the capacity using the SigmaJunmaSize+ Capacity Selection Software or other means.	Change the regenerative resistance value or capacity. Reconsider the operating conditions using the SigmaJunmaSize+ Capacity Selection Software or other means.	*2
		There was a continuous regeneration state because a negative load was continuously applied.	Check the load applied to the Servomotor during operation.	Reconsider the system including the servo, machine, and operating conditions.	—
		The setting of Pn600 (Regenerative Resistor Capacity) is smaller than the capacity of the External Regenerative Resistor.	Check to see if a Regenerative Resistor is connected and check the setting of Pn600.	Correct the setting of Pn600.	↪ Chap. 6.18 'Setting the Regenerative Resistor Capacity' ...page 187
		The setting of Pn603 (Regenerative Resistance) is smaller than the capacity of the External Regenerative Resistor.	Check to see if a Regenerative Resistor is connected and check the setting of Pn603.	Correct the setting of Pn603.	↪ Chap. 6.18 'Setting the Regenerative Resistor Capacity' ...page 187
		The external regenerative resistance is too high.	Check the regenerative resistance.	Change the regenerative resistance to a correct value or use an External Regenerative Resistor of an appropriate capacity.	*2
		A failure occurred in the SERVOPACK.	—	The SERVOPACK may be faulty. Replace the SERVOPACK.	—
A.330 (1330h)	Main Circuit Power Supply Wiring Error (Detected when the main circuit power supply is turned ON.)	The Regenerative Resistor was disconnected when the SERVOPACK power supply voltage was high.	Measure the resistance of the Regenerative Resistor using a measuring instrument.	If you are using the Regenerative Resistor built into the SERVOPACK, replace the SERVOPACK. If you are using an External Regenerative Resistor, replace the External Regenerative Resistor.	—
		DC power was supplied when an AC power supply input was specified in the settings.	Check the power supply to see if it is a DC power supply.	Correct the power supply setting to match the actual power supply.	↪ Chap. 6.3.1 'Power Supply Type Settings for the Main Cir-

Alarm Code	Alarm Name	Possible Cause	Confirmation	Correction	Reference
		AC power was supplied when a DC power supply input was specified in the settings.	Check the power supply to see if it is an AC power supply.	Correct the power supply setting to match the actual power supply.	cuit and Control Circuit' ...page 138
		Pn600 (2600h) (Regenerative Resistor Capacity) (setting unit: 10 W) is not set to 0 and an External Regenerative Resistor is not connected to one of the following SERVOPACKs: SGD7S-R70A, -R90A, -1R6A, -2R8A, -R70F, -R90F, -2R1F, or -2R8F.	Check to see if an External Regenerative Resistor is connected and check the setting of Pn600 (2600h).	Connect an External Regenerative Resistor, or if an External Regenerative Resistor is not required, set Pn600 (2600h) to 0.	↪ Chap. 5.4.6 'Wiring Regenerative Resistors' ...page 102, ↪ Chap. 6.18 'Setting the Regenerative Resistor Capacity' ...page 187
		A failure occurred in the SERVOPACK.	–	The SERVOPACK may be faulty. Replace the SERVOPACK.	–
A.400 (1400h)	Overvoltage (Detected in the main circuit power supply section of the SERVOPACK.)	The power supply voltage exceeded the specified range.	Measure the power supply voltage.	Set the AC/DC power supply voltage within the specified range.	–
		The power supply is not stable or was influenced by a lightning surge.	Measure the power supply voltage.	Improve the power supply conditions, install a Surge Absorber, and then turn the power supply OFF and ON again. If an alarm still occurs, the SERVOPACK may be faulty. Replace the SERVOPACK.	–
		The voltage for AC power supply was too high during acceleration or deceleration.	Check the power supply voltage and the speed and torque during operation.	Set the AC power supply voltage within the specified range	–
		The external regenerative resistance is too high for the operating conditions.	Check the operating conditions and the regenerative resistance.	Select a regenerative resistance value that is appropriate for the operating conditions and load.	*2
		The moment of inertia ratio or mass ratio exceeded the allowable value.	Check to see if the moment of inertia ratio or mass ratio is within the allowable range.	Increase the deceleration time, or reduce the load.	–

Alarm Code	Alarm Name	Possible Cause	Confirmation	Correction	Reference
		A failure occurred in the SERVOPACK.	–	While the main circuit power supply is OFF, turn the control power supply to the SERVOPACK OFF and ON again. If an alarm still occurs, the SERVOPACK may be faulty. Replace the SERVOPACK.	–
A.410 (1410h)	Undervoltage (Detected in the main circuit power supply section of the SERVOPACK.)	The power supply voltage went below the specified range.	Measure the power supply voltage.	Set the power supply voltage within the specified range.	–
		The power supply voltage dropped during operation.	Measure the power supply voltage.	Increase the power supply capacity.	–
		A momentary power interruption occurred.	Measure the power supply voltage.	If you have changed the setting of Pn509 (Momentary Power Interruption Hold Time), decrease the setting.	→ Chap. 7.3 'Operation for Momentary Power Interruptions' ...page 200
		The SERVOPACK fuse is blown out.	–	Replace the SERVOPACK and connect a reactor to the DC Reactor terminals (⊖1 and ⊖2) on the SERVOPACK.	–
		A failure occurred in the SERVOPACK.	–	The SERVOPACK may be faulty. Replace the SERVOPACK.	–
A.510 (1510h)	Overspeed (The motor exceeded the maximum speed.)	The order of phases U, V, and W in the motor wiring is not correct.	Check the wiring of the Servomotor.	Make sure that the Servomotor is correctly wired.	–
		A reference value that exceeded the over-speed detection level was input.	Check the input reference.	Reduce the reference value. Or, adjust the gain.	–
		The motor exceeded the maximum speed.	Check the waveform of the motor speed.	Reduce the speed reference input gain and adjust the servo gain. Or, reconsider the operating conditions.	–
		A failure occurred in the SERVOPACK.	–	The SERVOPACK may be faulty. Replace the SERVOPACK.	–
A.511 (1511h)	Encoder Output Pulse Over-speed	The encoder output pulse frequency exceeded the limit.	Check the encoder output pulse setting.	Decrease the setting of Pn212 (Encoder Output Pulses) or Pn281 (Encoder Output Resolution).	→ Chap. 7.6.3 'Setting for the Encoder Divided Pulse Output' ...page 210

Alarm Code	Alarm Name	Possible Cause	Confirmation	Correction	Reference
		The encoder output pulse frequency exceeded the limit because the motor speed was too high.	Check the encoder output pulse setting and the motor speed.	Reduce the motor speed.	–
A.520 (1520h)	Vibration Alarm	Abnormal oscillation was detected in the motor speed.	Check for abnormal motor noise, and check the speed and torque waveforms during operation.	Reduce the motor speed. Or, reduce the setting of Pn100 (Speed Loop Gain).	↪ Chap. 9.14.1 'Manual Tuning' ...page 384
		The setting of Pn103 (Moment of Inertia Ratio) is greater than the actual moment of inertia or was greatly changed.	Check the moment of inertia ratio or mass ratio.	Correct the setting of Pn103.	↪ Chap. 9.6.1 'Estimating the Moment of Inertia' ...page 295
		The vibration detection level (Pn312 or Pn384) is not suitable.	Check that the vibration detection level (Pn312 or Pn384) is suitable.	Set a suitable vibration detection level (Pn312 or Pn384).	↪ Chap. 7.12.1 'Initializing the Vibration Detection Level' ...page 236
A.521 (1521h)	Autotuning Alarm (Vibration was detected while executing the custom tuning, Easy FFT, or the tuning-less function.)	The Servomotor vibrated considerably while performing the tuning-less function.	Check the waveform of the motor speed.	Reduce the load so that the moment of inertia ratio is within the allowable value. Or increase the load level or reduce the rigidity level in the tuning-less level settings.	↪ Chap. 9.5.1 'Tuning-less Function' ...page 290
		The Servomotor vibrated considerably while performing custom tuning or Easy FFT.	Check the waveform of the motor speed.	Check the operating procedure of corresponding function and implement corrections.	↪ Chap. 9.9.1 'Custom Tuning' ...page 332 , ↪ Chap. 9.15.2 'Easy FFT' ...page 403
A.550 (1550h)	Maximum Speed Setting Error	The setting of Pn385 (Maximum Motor Speed) is greater than the maximum speed.	Check the setting of Pn385, and the upper limits of the maximum motor speed setting and the encoder output resolution setting.	Set Pn385 to a value that does not exceed the maximum motor speed.	↪ Chap. 7.5 'Setting the Motor Maximum Speed' ...page 203
A.710 (1710h)	Instantaneous Overload	The wiring is not correct or there is a faulty contact in the motor or encoder wiring.	Check the wiring.	Make sure that the Servomotor and encoder are correctly wired.	↪ Chap. 5.5.1 'Wiring Servomotors' ...page 105
A.720 (1720h)	Continuous Overload	Operation was performed that exceeded the overload protection characteristics.	Check the motor overload characteristics and Run command.	Reconsider the load and operating conditions. Or, increase the motor capacity.	–

Alarm Code	Alarm Name	Possible Cause	Confirmation	Correction	Reference
		An excessive load was applied during operation because the Servomotor was not driven due to mechanical problems.	Check the operation reference and motor speed.	Correct the mechanical problem.	–
		There is an error in the setting of Pn282 (Linear Encoder Pitch).	Check the setting of Pn282.	Correct the setting of Pn282.	→ Chap. 6.6 'Setting the Linear Encoder Pitch' ...page 142
		There is an error in the setting of Pn080 = n.□□X□ (Motor Phase Selection).	Check the setting of Pn080 = n.□□X□.	Set Pn080 = n.□□X□ to an appropriate value.	→ Chap. 6.8 'Selecting the Phase Sequence for a Linear Servomotor' ...page 150
		A failure occurred in the SERVOPACK.	–	The SERVOPACK may be faulty. Replace the SERVOPACK.	–
A.730 (1730h) and A.731 (1731h)	Dynamic Brake Overload (An excessive power consumption by the dynamic brake was detected.)	The Servomotor was rotated by an external force.	Check the operation status.	Implement measures to ensure that the motor will not be rotated by an external force.	–
		When the Servomotor was stopped with the dynamic brake, the rotational or linear kinetic energy exceeded the capacity of the Dynamic Brake Resistor.	Check the power consumed by the DB resistor to see how frequently the DB is being used.	Reconsider the following: <ul style="list-style-type: none"> ■ Reduce the Servomotor command speed. ■ Decrease the moment of inertia ratio or mass ratio. ■ Reduce the frequency of stopping with the dynamic brake. 	–
		A failure occurred in the SERVOPACK.	–	The SERVOPACK may be faulty. Replace the SERVOPACK.	–
A.740 (1740h)	Inrush Current Limiting Resistor Overload (The main circuit power supply was frequently turned ON and OFF.)	The allowable frequency of the inrush current limiting resistor was exceeded when the main circuit power supply was turned ON and OFF.	–	Reduce the frequency of turning the main circuit power supply ON and OFF.	–
		A failure occurred in the SERVOPACK.	–	The SERVOPACK may be faulty. Replace the SERVOPACK.	–

Alarm Code	Alarm Name	Possible Cause	Confirmation	Correction	Reference
A.7A1 (17A1h)	Internal Temperature Error 1 (Control Board Temperature Error)	The surrounding temperature is too high.	Check the surrounding temperature using a thermometer. Or, check the operating status with the SERVOPACK installation environment monitor.	Decrease the surrounding temperature by improving the SERVOPACK installation conditions.	→ Chap. 4.6 'Monitoring the Installation Environment' ...page 79
		An overload alarm was reset by turning OFF the power supply too many times.	Check the alarm display to see if there is an overload alarm.	Change the method for resetting the alarm.	–
		There was an excessive load or operation was performed that exceeded the regenerative processing capacity.	Use the accumulated load ratio to check the load during operation, and use the regenerative load ratio to check the regenerative processing capacity.	Reconsider the load and operating conditions.	–
		The SERVOPACK installation orientation is not correct or there is insufficient space around the SERVOPACK.	Check the SERVOPACK installation conditions.	Install the SERVOPACK according to specifications.	→ Chap. 4.3 'Mounting Types and Orientation' ...page 74, → Chap. 4.5.1 'Mounting Interval' ...page 78
		A failure occurred in the SERVOPACK.	–	The SERVOPACK may be faulty. Replace the SERVOPACK.	–
A.7A2 (17A2h)	Internal Temperature Error 2 (Power Board Temperature Error)	The surrounding temperature is too high.	Check the surrounding temperature using a thermometer. Or, check the operating status with the SERVOPACK installation environment monitor.	Decrease the surrounding temperature by improving the SERVOPACK installation conditions.	→ Chap. 4.6 'Monitoring the Installation Environment' ...page 79
		An overload alarm was reset by turning OFF the power supply too many times.	Check the alarm display to see if there is an overload alarm.	Change the method for resetting the alarm.	–
		There was an excessive load or operation was performed that exceeded the regenerative processing capacity.	Use the accumulated load ratio to check the load during operation, and use the regenerative load ratio to check the regenerative processing capacity.	Reconsider the load and operating conditions.	–

Alarm Code	Alarm Name	Possible Cause	Confirmation	Correction	Reference
		The SERVOPACK installation orientation is not correct or there is insufficient space around the SERVOPACK.	Check the SERVOPACK installation conditions.	Install the SERVOPACK according to specifications.	→ Chap. 4.3 'Mounting Types and Orientation' ...page 74 , → Chap. 4.5.1 'Mounting Interval' ...page 78
		A failure occurred in the SERVOPACK.	–	The SERVOPACK may be faulty. Replace the SERVOPACK.	–
A.7A3 (17A3h)	Internal Temperature Sensor Error (An error occurred in the temperature sensor circuit.)	A failure occurred in the SERVOPACK.	–	The SERVOPACK may be faulty. Replace the SERVOPACK.	–
A.7Ab (17Abh)	SERVOPACK Built-in Fan Stopped	The fan inside the SERVOPACK stopped.	Check for foreign matter inside the SERVOPACK.	Remove foreign matter from the SERVOPACK. If an alarm still occurs, the SERVOPACK may be faulty. Replace the SERVOPACK.	–
A.810 (1810h)	Encoder Backup Alarm (Detected at the encoder, but only when an absolute encoder is used.)	The power to the absolute encoder was turned ON for the first time.	Check to see if the power supply was turned ON for the first time.	Set up the encoder.	→ Chap. 6.16.1 'Resetting the Absolute Encoder' ...page 179
		The Encoder Cable was disconnected and then connected again.	Check to see if the power supply was turned ON for the first time.	Check the encoder connection and set up the encoder.	
		Power is not being supplied both from the control power supply (+5 V) from the SERVOPACK and from the battery power supply.	Check the encoder connector battery and the connector status.	Replace the battery or implement similar measures to supply power to the encoder, and set up the encoder.	
		A failure occurred in the absolute encoder.	–	If the alarm still occurs after setting up the encoder again, replace the Servomotor.	–
		A failure occurred in the SERVOPACK.	–	The SERVOPACK may be faulty. Replace the SERVOPACK.	–

Alarm Code	Alarm Name	Possible Cause	Confirmation	Correction	Reference
A.820 (1820h)	Encoder Checksum Alarm (Detected at the encoder.)	A failure occurred in the encoder.	–	<ul style="list-style-type: none"> ■ When Using an Absolute Encoder <ul style="list-style-type: none"> – Set up the encoder again. If the alarm still occurs, the Servomotor may be faulty. Replace the Servomotor. ■ When Using a Singleturn Absolute Encoder or Incremental Encoder <ul style="list-style-type: none"> – The Servomotor may be faulty. Replace the Servomotor. – The linear encoder may be faulty. Replace the linear encoder. 	→ Chap. 6.16.1 'Resetting the Absolute Encoder' ...page 179
		A failure occurred in the SERVOPACK.	–	The SERVOPACK may be faulty. Replace the SERVOPACK.	–
A.830 (1830h)	Encoder Battery Alarm (The absolute encoder battery voltage was lower than the specified level.)	The battery connection is faulty or a battery is not connected.	Check the battery connection.	Correct the battery connection.	→ Chap. 5.5.3.1 'Wiring the SERVOPACK to the Encoder' ...page 106
		The battery voltage is lower than the specified value (2.7 V).	Measure the battery voltage.	Replace the battery.	→ Chap. 16.2.4 'Replacing the Battery' ...page 547
		A failure occurred in the SERVOPACK.	–	The SERVOPACK may be faulty. Replace the SERVOPACK.	–
A.840 (1840h)	Encoder Data Alarm (Detected at the encoder.)	The encoder malfunctioned.	–	Turn the power supply to the SERVOPACK OFF and ON again. If the alarm still occurs, the Servomotor or linear encoder may be faulty. Replace the Servomotor or linear encoder.	–

Alarm Code	Alarm Name	Possible Cause	Confirmation	Correction	Reference
		An error occurred in reading data from the linear encoder.	–	The linear encoder is not mounted within an appropriate tolerance. Correct the mounting of the linear encoder.	–
		Excessive speed occurred in the linear encoder.	–	Control the motor speed within the range specified by the linear encoder manufacturer and then turn ON the control power supply.	–
		The encoder malfunctioned due to noise.	–	Correct the wiring around the encoder by separating the Encoder Cable from the Servomotor Main Circuit Cable or by grounding the encoder.	–
		The polarity sensor is not wired correctly.	Check the wiring of the polarity sensor.	Correct the wiring of the polarity sensor.	–
		The polarity sensor failed.	–	Replace the polarity sensor.	–
A.850 (1850h)	Encoder Over-speed (Detected at the encoder when the control power supply is turned ON.)	Rotary Servomotor: The Servomotor speed was 200 min ⁻¹ or higher when the control power supply was turned ON.	Check the motor speed when the power supply is turned ON.	Reduce the Servomotor speed to a value less than 200 min ⁻¹ , and turn ON the control power supply.	–
		Linear Servomotor: The Servomotor exceeded the specified speed when the control power supply was turned ON.		Control the motor speed within the range specified by the linear encoder manufacturer and then turn ON the control power supply.	–
		A failure occurred in the encoder.	–	Turn the power supply to the SERVOPACK OFF and ON again. If an alarm still occurs, the Servomotor or linear encoder may be faulty. Replace the Servomotor or linear encoder.	–
		A failure occurred in the SERVOPACK.	–	Turn the power supply to the SERVOPACK OFF and ON again. If an alarm still occurs, the SERVOPACK may be faulty. Replace the SERVOPACK.	–

Alarm Code	Alarm Name	Possible Cause	Confirmation	Correction	Reference
A.860 (1860h)	Encoder Overheated (Detected at the encoder, but only when an absolute encoder is used.)	The surrounding air temperature around the Servomotor is too high.	Measure the surrounding air temperature around the Servomotor.	Reduce the surrounding air temperature of the Servomotor to 40°C or less.	—
		The Servomotor load is greater than the rated load.	Use the accumulated load ratio to check the load.	Operate the Servo Drive so that the motor load remains within the specified range.	↔ Chap. 10.3.1 'Monitoring SERVOPACK Status' ...page 411
		A failure occurred in the encoder.	—	Turn the power supply to the SERVOPACK OFF and ON again. If the alarm still occurs, the Servomotor or absolute linear encoder may be faulty. Replace the Servomotor or absolute linear encoder.	—
		A failure occurred in the SERVOPACK.	—	Turn the power supply to the SERVOPACK OFF and ON again. If the alarm still occurs, the SERVOPACK may be faulty. Replace the SERVOPACK.	—
A.861 (1861h)	Motor Overheated	The surrounding temperature around the Servomotor is too high.	Measure the surrounding temperature around the Servomotor.	Reduce the surrounding air temperature of the Servomotor to 40°C or less.	—
		The motor load is greater than the rated load.	Check the load with the accumulated load ratio on the Motion Monitor Tab Page on the SigmaWin+.	Operate the Servo Drive so that the motor load remains within the specified range.	↔ Chap. 10.3.1 'Monitoring SERVOPACK Status' ...page 411
		A failure occurred in the Serial Converter Unit.	—	Turn the power supply to the SERVOPACK OFF and ON again. If the alarm still occurs, the Serial Converter Unit may be faulty. Replace the Serial Converter Unit.	—
		A failure occurred in the SERVOPACK.	—	Turn the power supply to the SERVOPACK OFF and ON again. If the alarm still occurs, the SERVOPACK may be faulty. Replace the SERVOPACK.	—

Alarm Code	Alarm Name	Possible Cause	Confirmation	Correction	Reference
A.862 (1862h)	Overheat Alarm	The surrounding temperature is too high.	Check the surrounding temperature using a thermometer.	Lower the surrounding temperature by improving the installation conditions of the Linear Servomotor or the machine.	—
		The overheat protection input signal line is disconnected or short-circuited.	Check the input voltage with the overheat protection input information on the Motion Monitor Tab Page on the SigmaWin+.	Repair the line for the overheat protection input signal.	—
		An overload alarm was reset by turning OFF the power supply too many times.	Check the alarm display to see if there is an overload alarm.	Change the method for resetting the alarm.	—
		Operation was performed under an excessive load.	Use the accumulated load ratio to check the load during operation.	Reconsider the load and operating conditions.	—
		A failure occurred in the SERVOPACK.	—	The SERVOPACK may be faulty. Replace the SERVOPACK.	—
		The temperature detection circuit in the Linear Servomotor is faulty or the sensor attached to the machine is faulty.	—	The temperature detection circuit in the Linear Servomotor may be faulty or the sensor attached to the machine may be faulty. Replace the Linear Servomotor or repair the sensor attached to the machine.	—
A.890 (1890h)	Encoder Scale Error	A failure occurred in the linear encoder.	—	The linear encoder may be faulty. Replace the linear encoder.	—
A.891 (1891h)	Encoder Module Error	A failure occurred in the linear encoder.	—	Turn the power supply to the SERVOPACK OFF and ON again. If the alarm still occurs, the linear encoder may be faulty. Replace the linear encoder.	—
A.8A0 (18A0h)	External Encoder Error	Setting the origin of the absolute linear encoder failed because the motor moved.	Before you set the origin, use the fully-closed feedback pulse counter to confirm that the motor is not moving.	The motor must be stopped while setting the origin position.	↪ Chap. 6.17.1 'Setting the Origin of the Absolute Encoder' ...page 183

Alarm Code	Alarm Name	Possible Cause	Confirmation	Correction	Reference
		A failure occurred in the external encoder.	–	Replace the external encoder.	–
A.8A1 (18A1h)	External Encoder Module Error	A failure occurred in the external encoder.	–	Replace the external encoder.	–
		A failure occurred in the Serial Converter Unit.	–	Replace the Serial Converter Unit.	–
A.8A2 (18A2h)	External Incremental Encoder Sensor Error	A failure occurred in the external encoder.	–	Replace the external encoder.	–
A.8A3 (18A3h)	External Absolute Encoder Position Error	A failure occurred in the external absolute encoder.	–	The external absolute encoder may be faulty. Refer to the encoder manufacturer's instruction manual for corrections.	–
A.8A5 (18A5h)	External Encoder Overspeed	An overspeed error was detected in the external encoder.	Check the maximum speed of the external encoder.	Keep the external encoder below its maximum speed.	–
A.8A6 (18A6h)	External Encoder Overheated	An overheating error was detected in the external encoder.	–	Replace the external encoder.	–
A.b33 (1b33h)	Current Detection Error 3	A failure occurred in the current detection circuit.	–	Turn the power supply to the SERVOPACK OFF and ON again. If the alarm still occurs, the SERVOPACK may be faulty. Replace the SERVOPACK.	–
A.bF0 (1bF0h)	System Alarm 0	A failure occurred in the SERVOPACK.	–	Turn the power supply to the SERVOPACK OFF and ON again. If the alarm still occurs, the SERVOPACK may be faulty. Replace the SERVOPACK.	–
A.bF1 (1bF1h)	System Alarm 1	A failure occurred in the SERVOPACK.	–	Turn the power supply to the SERVOPACK OFF and ON again. If the alarm still occurs, the SERVOPACK may be faulty. Replace the SERVOPACK.	–
A.bF2 (1bF2h)	System Alarm 2	A failure occurred in the SERVOPACK.	–	Turn the power supply to the SERVOPACK OFF and ON again. If the alarm still occurs, the SERVOPACK may be faulty. Replace the SERVOPACK.	–

Alarm Code	Alarm Name	Possible Cause	Confirmation	Correction	Reference
A.bF3 (1bF3h)	System Alarm 3	A failure occurred in the SERVOPACK.	–	Turn the power supply to the SERVOPACK OFF and ON again. If the alarm still occurs, the SERVOPACK may be faulty. Replace the SERVOPACK.	–
A.bF4 (1bF4h)	System Alarm 4	A failure occurred in the SERVOPACK.	–	Turn the power supply to the SERVOPACK OFF and ON again. If the alarm still occurs, the SERVOPACK may be faulty. Replace the SERVOPACK.	–
A.bF5 (1bF5h)	System Alarm 5	A failure occurred in the SERVOPACK.	–	Turn the power supply to the SERVOPACK OFF and ON again. If the alarm still occurs, the SERVOPACK may be faulty. Replace the SERVOPACK.	–
A.bF6 (1bF6h)	System Alarm 6	A failure occurred in the SERVOPACK.	–	Turn the power supply to the SERVOPACK OFF and ON again. If the alarm still occurs, the SERVOPACK may be faulty. Replace the SERVOPACK.	–
A.bF7 (1bF7h)	System Alarm 7	A failure occurred in the SERVOPACK.	–	Turn the power supply to the SERVOPACK OFF and ON again. If the alarm still occurs, the SERVOPACK may be faulty. Replace the SERVOPACK.	–
A.bF8 (1bF8h)	System Alarm 8	A failure occurred in the SERVOPACK.	–	Turn the power supply to the SERVOPACK OFF and ON again. If the alarm still occurs, the SERVOPACK may be faulty. Replace the SERVOPACK.	–
A.C10 (1C10h)	Servomotor Out of Control (Detected when the servo is turned ON.)	The order of phases U, V, and W in the motor wiring is not correct.	Check the Servomotor wiring.	Make sure that the Servomotor is correctly wired.	–

Alarm Code	Alarm Name	Possible Cause	Confirmation	Correction	Reference
		There is an error in the setting of Pn080 = n.□□X□ (Motor Phase Selection).	Check the setting of Pn080 = n.□□X□.	Set Pn080 = n.□□X□ to an appropriate value.	→ Chap. 6.8 'Selecting the Phase Sequence for a Linear Servomotor' ...page 150
		A failure occurred in the encoder.	–	If the motor wiring is correct and an alarm still occurs after turning the power supply OFF and ON again, the Servomotor or linear encoder may be faulty. Replace the Servomotor or linear encoder.	–
		A failure occurred in the SERVOPACK.	–	Turn the power supply to the SERVOPACK OFF and ON again. If the alarm still occurs, the SERVOPACK may be faulty. Replace the SERVOPACK.	–
A.C20 (1C20h)	Phase Detection Error	The linear encoder signal level is too low.	Check the voltage of the linear encoder signal.	Fine-tune the mounting of the scale head. Or, replace the linear encoder.	–
		The count-up direction of the linear encoder does not match the forward direction of the Moving Coil in the motor.	Check the setting of Pn080 = n.□□X□ (Motor Phase Sequence Selection). Check the installation orientation for the linear encoder and Moving Coil.	Change the setting of Pn080 = n.□□X□. Correctly reinstall the linear encoder or Moving Coil.	→ Chap. 6.8 'Selecting the Phase Sequence for a Linear Servomotor' ...page 150
		The polarity sensor signal is being affected by noise.	–	Correct the FG wiring. Implement countermeasures against noise for the polarity sensor wiring.	–
		The setting of Pn282 (Linear Encoder Scale Pitch) is not correct.	Check the setting of Pn282 (Linear Encoder Scale Pitch).	Check the specifications of the linear encoder and set a correct value.	→ Chap. 6.6 'Setting the Linear Encoder Pitch' ...page 142
A.C21 (1C21h)	Polarity Sensor Error	The polarity sensor is protruding from the Magnetic Way of the motor.	Check the polarity sensor.	Correctly reinstall the Moving Coil or Magnetic Way of the motor.	–
		The polarity sensor is not wired correctly.	Check the wiring of the polarity sensor.	Correct the wiring of the polarity sensor.	–

Alarm Code	Alarm Name	Possible Cause	Confirmation	Correction	Reference
		The polarity sensor failed.	–	Replace the polarity sensor.	–
A.C22 (1C22h)	Phase Information Disagreement	The SERVOPACK phase information is different from the linear encoder phase information.	–	Perform polarity detection.	➔ Chap. 6.10.4 'Using a Tool Function to Perform Polarity Detection' ...page 154
A.C50 (1C50h)	Polarity Detection Failure	The parameter settings are not correct.	Check the linear encoder specifications and feedback signal status.	The settings of Pn282 (Linear Encoder Pitch) and Pn080 = n.□□X□ (Motor Phase Selection) may not match the installation. Set the parameters to correct values.	➔ Chap. 6.6 'Setting the Linear Encoder Pitch' ...page 142, ➔ Chap. 6.8 'Selecting the Phase Sequence for a Linear Servomotor' ...page 150
		There is noise on the scale signal.	Check to make sure that the frame grounds of the Serial Converter Unit and Servomotor are connected to the FG terminal on the SERVOPACK and that the FG terminal on the SERVOPACK is connected to the frame ground on the power supply. And, confirm that the shield is properly processed on the Linear Encoder Cable. Check to see if the detection reference is repeatedly output in one direction.	Implement appropriate countermeasures against noise for the Linear Encoder Cable.	–

Alarm Code	Alarm Name	Possible Cause	Confirmation	Correction	Reference
		An external force was applied to the Moving Coil of the motor.	–	The polarity cannot be properly detected if the detection reference is 0 and the speed feedback is not 0 because of an external force, such as cable tension, applied to the Moving Coil. Implement measures to reduce the external force so that the speed feedback goes to 0. If the external force cannot be reduced, increase the setting of Pn481 (Polarity Detection Speed Loop Gain).	–
		The linear encoder resolution is too low.	Check the linear encoder scale pitch to see if it is within 100 µm.	If the linear encoder scale pitch is 100 µm or higher, the SERVOPACK cannot detect the correct speed feedback. Use a linear encoder scale pitch with higher resolution. (We recommend a pitch of 40 µm or less.) Or, increase the setting of Pn485 (Polarity Detection Reference Speed). However, increasing the setting of Pn485 will increase the Servomotor movement range that is required for polarity detection.	–
A.C51 (1C51h)	Overtravel Detected during Polarity Detection	The overtravel signal was detected during polarity detection.	Check the overtravel position.	Wire the overtravel signals. Execute polarity detection at a position where an overtravel signal would not be detected.	↪ Chap. 5.6.3 'I/O Signal Wiring Examples' ...page 117
A.C52 (1C52h)	Polarity Detection Not Completed	The servo was turned ON when using an absolute linear encoder, Pn587 was set to n.□□□0 (Do not detect polarity), and the polarity had not been detected.	–	When using an absolute linear encoder, set Pn587 to n.□□□1 (Detect polarity)	–

Alarm Code	Alarm Name	Possible Cause	Confirmation	Correction	Reference
A.C53 (1C53h)	Out of Range of Motion for Polarity Detection	The travel distance exceeded the setting of Pn48E (Polarity Detection Range) in the middle of detection.	–	Increase the setting of Pn48E (Polarity Detection Range). Or, increase the setting of Pn481 (Polarity Detection Speed Loop Gain).	–
A.C54 (1C54h)	Polarity Detection Failure 2	An external force was applied to the Servomotor.	–	Increase the setting of Pn495 (Polarity Detection Confirmation Force Reference). Increase the setting of Pn498 (Polarity Detection Allowable Error Range). Increasing the allowable error will also increase the motor temperature.	–
A.C80 (1C80h)	Encoder Clear Error or Multi-turn Limit Setting Error	A failure occurred in the encoder.	–	Turn the power supply to the SERVOPACK OFF and ON again. If an alarm still occurs, the Servomotor or linear encoder may be faulty. Replace the Servomotor or linear encoder.	–
		A failure occurred in the SERVOPACK.	–	Turn the power supply to the SERVOPACK OFF and ON again. If the alarm still occurs, the SERVOPACK may be faulty. Replace the SERVOPACK.	–
A.C90 (1C90h)	Encoder Communications Error	There is a faulty contact in the connector or the connector is not wired correctly for the encoder.	Check the condition of the encoder connector.	Reconnect the encoder connector and check the encoder wiring.	↪ Chap. 5.5.1 'Wiring Servomotors' ...page 105
		There is a cable disconnection or shortcircuit in the encoder. Or, the cable impedance is outside the specified values.	Check the condition of the Encoder Cable.	Use the Encoder Cable within the specified specifications.	–
		One of the following has occurred: corrosion caused by improper temperature, humidity, or gas, a short-circuit caused by entry of water drops or cutting oil, or faulty contact in connector caused by vibration.	Check the operating environment.	Improve the operating environmental, and replace the cable. If the alarm still occurs, replace the SERVOPACK.	↪ Chap. 4.3 'Mounting Types and Orientation' ...page 74

Alarm Code	Alarm Name	Possible Cause	Confirmation	Correction	Reference
		A malfunction was caused by noise.	–	Correct the wiring around the encoder by separating the Encoder Cable from the Servomotor Main Circuit Cable or by grounding the encoder.	↪ Chap. 5.2.2 'Countermeasures against Noise' ...page 86
		A failure occurred in the SERVOPACK.	–	Connect the Servomotor to another SERVOPACK, and turn ON the control power supply. If no alarm occurs, the SERVOPACK may be faulty. Replace the SERVOPACK.	–
A.C91 (1C91h)	Encoder Communications Position Data Acceleration Rate Error	Noise entered on the signal lines because the Encoder Cable is bent or the sheath is damaged.	Check the condition of the Encoder Cable and connectors.	Check the Encoder Cable to see if it is installed correctly.	↪ Chap. 5.2.3 'Grounding' ...page 89
		The Encoder Cable is bundled with a high-current line or installed near a high-current line.	Check the installation condition of the Encoder Cable.	Confirm that there is no surge voltage on the Encoder Cable.	–
		There is variation in the FG potential because of the influence of machines on the Servomotor side, such as a welder.	Check the installation condition of the Encoder Cable.	Properly ground the machine to separate it from the FG of the encoder.	–
A.C92 (1C92h)	Encoder Communications Timer Error	Noise entered on the signal line from the encoder.	–	Implement countermeasures against noise for the encoder wiring.	↪ Chap. 5.2.2 'Countermeasures against Noise' ...page 86
		Excessive vibration or shock was applied to the encoder.	Check the operating conditions.	Reduce machine vibration. Correctly install the Servomotor or linear encoder.	–
		A failure occurred in the encoder.	–	Turn the power supply to the SERVOPACK OFF and ON again. If the alarm still occurs, the Servomotor or linear encoder may be faulty. Replace the Servomotor or linear encoder.	–

Alarm Code	Alarm Name	Possible Cause	Confirmation	Correction	Reference
		A failure occurred in the SERVOPACK.	–	Turn the power supply to the SERVOPACK OFF and ON again. If the alarm still occurs, the SERVOPACK may be faulty. Replace the SERVOPACK.	–
A.CA0 (1CA0h)	Encoder Parameter Error	A failure occurred in the encoder.	–	Turn the power supply to the SERVOPACK OFF and ON again. If the alarm still occurs, the Servomotor or linear encoder may be faulty. Replace the Servomotor or linear encoder.	–
		A failure occurred in the SERVOPACK.	–	Turn the power supply to the SERVOPACK OFF and ON again. If the alarm still occurs, the SERVOPACK may be faulty. Replace the SERVOPACK.	–
A.Cb0 (1Cb0h)	Encoder Echo-back Error	The encoder is wired incorrectly or there is faulty contact.	Check the wiring of the encoder.	Make sure that the encoder is correctly wired.	↔ Chap. 5.5.1 'Wiring Servomotors' ...page 105
		The specifications of the Encoder Cable are not correct and noise entered on it.	–	Use a shielded twisted-pair wire cable or a screened twisted-pair cable with conductors of at least 0.12 mm ² .	–
		The Encoder Cable is too long and noise entered on it.	–	<ul style="list-style-type: none"> ■ Rotary Servomotors: The Encoder Cable wiring distance must be 50 m max. ■ Linear Servomotors: The Encoder Cable wiring distance must be 20 m max. 	–
		There is variation in the FG potential because of the influence of machines on the Servomotor side, such as a welder.	Check the condition of the Encoder Cable and connectors.	Properly ground the machine to separate it from the FG of the encoder.	–
		Excessive vibration or shock was applied to the encoder.	Check the operating conditions.	Reduce machine vibration. Correctly install the Servomotor or linear encoder.	–

Alarm Code	Alarm Name	Possible Cause	Confirmation	Correction	Reference
		A failure occurred in the encoder.	–	Turn the power supply to the SERVOPACK OFF and ON again. If the alarm still occurs, the Servomotor or linear encoder may be faulty. Replace the Servomotor or linear encoder.	–
		A failure occurred in the SERVOPACK.	–	Turn the power supply to the SERVOPACK OFF and ON again. If the alarm still occurs, the SERVOPACK may be faulty. Replace the SERVOPACK.	–
A.CC0 (1CC0h)	Multiturn Limit Disagreement	When using a Direct Drive Servomotor, the setting of Pn205 (Multiturn Limit) does not agree with the encoder.	Check the setting of Pn205.	Correct the setting of Pn205 (0 to 65,535).	↪ Chap. 7.9.9 'Multiturn Limit Disagreement Alarm (A.CC0)' ...page 225
		The multiturn limit of the encoder is different from that of the SERVOPACK. Or, the multiturn limit of the SERVOPACK has been changed.	Check the setting of Pn205 (Multiturn Limit).	Change the setting if the alarm occurs.	↪ Chap. 7.9.9 'Multiturn Limit Disagreement Alarm (A.CC0)' ...page 225
		A failure occurred in the SERVOPACK.	–	Turn the power supply to the SERVOPACK OFF and ON again. If the alarm still occurs, the SERVOPACK may be faulty. Replace the SERVOPACK.	–
A.CF1 (1CF1h)	Reception Failed Error in Feedback Option Module Communications	The cable between the Serial Converter Unit and SERVOPACK is not wired correctly or there is a faulty contact.	Check the wiring of the external encoder.	Correctly wire the cable between the Serial Converter Unit and SERVOPACK.	↪ Chap. 5.5.3.1 'Wiring the SERVOPACK to the Encoder' ...page 106
		A specified cable is not being used between Serial Converter Unit and SERVOPACK.	Check the wiring specifications of the external encoder.	Use a specified cable.	–
		The cable between the Serial Converter Unit and SERVOPACK is too long.	Measure the length of the cable that connects the Serial Converter Unit.	The length of the cable between the Serial Converter Unit and SERVOPACK must be 20 m or less.	–

Alarm Code	Alarm Name	Possible Cause	Confirmation	Correction	Reference
		The sheath on cable between the Serial Converter Unit and SERVOPACK is broken.	Check the cable that connects the Serial Converter Unit.	Replace the cable between the Serial Converter Unit and SERVOPACK.	–
A.CF2 (1CF2h)	Timer Stopped Error in Feedback Option Module Communications	Noise entered the cable between the Serial Converter Unit and SERVOPACK.	–	Correct the wiring around the Serial Converter Unit, e.g., separate I/O signal lines from the Main Circuit Cables or ground.	–
		A failure occurred in the Serial Converter Unit.	–	Replace the Serial Converter Unit.	–
		A failure occurred in the SERVOPACK.	–	Replace the SERVOPACK.	–
A.d00 (1d00h)	Position Deviation Overflow (The setting of Pn520 (Excessive Position Error Alarm Level) was exceeded by the position deviation while the servo was ON.)	The Servomotor U, V, and W wiring is not correct.	Check the wiring of the Servomotor's Main Circuit Cables.	Make sure that there are no faulty contacts in the wiring for the Servomotor and encoder.	–
		The position command speed is too fast.	Reduce the position command speed and try operating the SERVOPACK.	Reduce the position reference speed or the reference acceleration rate, or reconsider the electronic gear ratio.	↔ Chap. 6.15.2 'Setting the Position Reference Unit' ...page 172
		The acceleration of the position reference is too high.	Reduce the reference acceleration and try operating the SERVOPACK.	Reduce the acceleration of the position reference using a PROFINET command.	–
		The setting of Pn520 (Excessive Position Deviation Alarm Level) is too low for the operating conditions.	Check the setting of Pn520 to see if it is appropriate.	Optimize the setting of Pn520.	↔ Chap. 9.4.1 'Precautions to Ensure Safe Tuning' ...page 286
		A failure occurred in the SERVOPACK.	–	Turn the power supply to the SERVOPACK OFF and ON again. If an alarm still occurs, the SERVOPACK may be faulty. Replace the SERVOPACK.	–
A.d01 (1d01h)	Position Deviation Overflow Alarm at Servo ON	The servo was turned ON after the position deviation exceeded the setting of Pn526 (Excessive Position Deviation Alarm Level at Servo ON) while the servo was OFF.	Check the position deviation while the servo is OFF.	Optimize the setting of Pn526.	↔ Chap. 9.4.1 'Precautions to Ensure Safe Tuning' ...page 286

Alarm Code	Alarm Name	Possible Cause	Confirmation	Correction	Reference
A.d02 (1d02h)	Position Deviation Overflow Alarm for Speed Limit at Servo ON	If position deviation remains in the deviation counter, the setting of Pn529 or Pn584 (Speed Limit Level at Servo ON) limits the speed when the servo is turned ON. This alarm occurs if a position reference is input and the setting of Pn520 (Excessive Position Deviation Alarm Level) is exceeded.	–	Optimize the setting of Pn520. Or, set Pn529 or Pn584 to an appropriate value.	
A.d10 (1d10h)	Motor-Load Position Deviation Overflow	The motor direction and external encoder installation orientation are backward.	Check the motor direction and the external encoder installation orientation.	Install the external encoder in the opposite direction, or change the setting of Pn002 = n.X□□□ (External Encoder Usage) to reverse the direction.	↪ Chap. 11.4.3 'Setting the Motor Direction and the Machine Movement Direction' ...page 433
		There is an error in the connection between the load (e.g., stage) and external encoder coupling.	Check the coupling of the external encoder.	Check the mechanical coupling.	–
A.d30 (1d30h)	Position Data Overflow	The position data exceeded $\pm 1,879,048,192$.	Check the input reference pulse counter.	Reconsider the operating specifications.	–
A.E00 (1E00h)	PROFINET Module Interface Initialization Timeout Error	A failure occurred in the SERVOPACK.	–	Replace the SERVOPACK.	–
A.E02 (1E02h)	PROFINET Internal Synchronization Error 1	The PROFINET transmission cycle fluctuated.	–	Remove the cause of transmission cycle fluctuation at the host controller.	–
		A failure occurred in the SERVOPACK.	–	Turn the power supply to the SERVOPACK OFF and ON again. If an alarm still occurs, the SERVOPACK may be faulty. Replace the SERVOPACK.	–
A.E03 (1E03h)	PROFINET Module Interface Communications Data Error	Noise caused an error in communications between the SERVOPACK and PROFINET Network Module.	–	Implement countermeasures against noise.	–
		A failure occurred in the SERVOPACK.	–	Replace the SERVOPACK.	–

Alarm Code	Alarm Name	Possible Cause	Confirmation	Correction	Reference
A.E71 (1E71h)	Safety Option Module Detection Failure	There is a faulty connection between the SERVOPACK and the Safety Option Module.	Check the connection between the SERVOPACK and the Safety Option Module.	Correctly connect the Safety Option Module.	–
		The Safety Option Module was disconnected.	–	Execute Fn014 (Reset Option Module Configuration Error) from the Digital Operator or SigmaWin+ and then turn the power supply OFF and ON again.	↪ Chap. 16.4.7 'Resetting Alarms Detected in Option Modules' ...page 597
		A failure occurred in the Safety Option Module.	–	Replace the Safety Option Module.	–
		A failure occurred in the SERVOPACK.	–	Replace the SERVOPACK.	–
A.E72 (1E72h)	Feedback Option Module Detection Failure	There is a faulty connection between the SERVOPACK and the Feedback Option Module.	Check the connection between the SERVOPACK and the Feedback Option Module.	Correctly connect the Feedback Option Module.	–
		The Feedback Option Module was disconnected.	–	Reset the Option Module configuration error and turn the power supply to the SERVOPACK OFF and ON again.	↪ Chap. 16.4.7 'Resetting Alarms Detected in Option Modules' ...page 597
		A failure occurred in the Feedback Option Module.	–	Replace the Feedback Option Module.	–
		A failure occurred in the SERVOPACK.	–	Replace the SERVOPACK.	–
A.E74 (1E74h)	Unsupported Safety Option Module Alarm	A failure occurred in the Safety Option Module.	–	Replace the Safety Option Module.	–
		An unsupported Safety Option Module was connected.	Refer to the manual for the connected Safety Option Module.	Connect a supported Safety Option Module.	–
A.E75 (1E75h)	Unsupported Feedback Option Module Alarm	A failure occurred in the Feedback Option Module.	–	Replace the Safety Option Module.	–
		An unsupported Feedback Option Module was connected.	Refer to the catalog for the connected Feedback Option Module or the SERVOPACK manual.	Connect a supported Feedback Option Module.	–

Alarm Code	Alarm Name	Possible Cause	Confirmation	Correction	Reference
A.Eb1 (1Eb1h)	Safety Function Signal Input Timing Error	The delay between activation of the / HWBB1 and /HWBB2 input signals for the HWBB was ten second or longer.	Measure the time delay between the /HWBB1 and / HWBB2 signals.	The output signal circuits or devices for /HWBB1 and / HWBB2 or the SER- VOPACK input signal circuits may be faulty. Alternatively, the input signal cables may be dis- connected. Check to see if any of these items are faulty or have been discon- nected.	–
		A failure occurred in the SERVOPACK.	–	Replace the SERVO- PACK.	–
A.EC8 (1EC8h)	Gate Drive Error 1 (An error occurred in the gate drive cir- cuit.)	A failure occurred in the SERVOPACK.	–	Turn the power supply to the SER- VOPACK OFF and ON again. If an alarm still occurs, the SERVOPACK may be faulty. Replace the SERVOPACK.	–
A.EC9 (1EC9h)	Gate Drive Error 2 (An error occurred in the gate drive cir- cuit.)				
A.Ed1 (1Ed1h)	Command Exe- cution Timeout	A timeout error occurred for a PROFINET command.	Check the motor status when the command is exe- cuted.	Execute the Servo ON command (Enable Operation command) only when the motor is not operating.	–
A.F10 (1F10h)	Power Supply Line Open Phase (The voltage was low for more than one second for phase R, S, or T when the main power supply was ON.)	The three-phase power supply wiring is not correct.	Check the power supply wiring.	Make sure that the power supply is cor- rectly wired.	↔ Chap. 5.4.1 'Wiring the Power Supply to the SERVO- PACK' ...page 91
		The three-phase power supply is unbal- anced.	Measure the voltage for each phase of the three-phase power supply.	Balance the power supply by changing phases.	–
		A single-phase power supply was input without specifying a single- phase AC power supply input (Pn00B = n.□1□□).	Check the power supply and the parameter setting.	Match the parameter setting to the power supply.	↔ Chap. 5.4.1 'Wiring the Power Supply to the SERVO- PACK' ...page 91
		A failure occurred in the SERVOPACK.	–	Turn the power supply to the SER- VOPACK OFF and ON again. If the alarm still occurs, the SERVOPACK may be faulty. Replace the SERVOPACK.	–

Alarm Code	Alarm Name	Possible Cause	Confirmation	Correction	Reference
FL-1*4	System Alarm	A failure occurred in the SERVOPACK.	–	Turn the power supply to the SERVOPACK OFF and ON again. If an alarm still occurs, the SERVOPACK may be faulty. Replace the SERVOPACK.	–
FL-2*4	System Alarm				
FL-3*4	System Alarm				
FL-4*4	System Alarm				
FL-5*4	System Alarm				
FL-6*4	System Alarm				
CPF00	Digital Operator Communications Error 1	There is a faulty contact between the Digital Operator and the SERVOPACK.	Check the connector contact.	Disconnect the connector and insert it again. Or, replace the cable.	–
		A malfunction was caused by noise.	–	Keep the Digital Operator or the cable away from sources of noise.	–
CPF01	Digital Operator Communications Error 2	A failure occurred in the Digital Operator.	–	Disconnect the Digital Operator and then connect it again. If an alarm still occurs, the Digital Operator may be faulty. Replace the Digital Operator.	–
		A failure occurred in the SERVOPACK.	–	Turn the power supply to the SERVOPACK OFF and ON again. If an alarm still occurs, the SERVOPACK may be faulty. Replace the SERVOPACK.	–

*1. Detection Conditions

■ Rotary Servomotor

If either of the following conditions is detected, an alarm will occur.

- $Pn533 \text{ [min}^{-1}] \times \frac{\text{Encoder resolution}}{6 \times 10^5} \leq 1$
- $\text{Maximum motor speed [min}^{-1}] \times \frac{\text{Encoder resolution}}{\text{Approx. } 3.66 \times 10^{12}} \geq 1$

Fig. 381: Formulae Detection conditions - Rotary Servomotor

■ Linear Servomotor

If either of the following conditions is detected, an alarm will occur.

- $\frac{Pn585 \text{ [mm/s]}}{\text{Linear encoder pitch [\mu m]}} \times \frac{\text{Resolution of Serial Converter Unit}}{10} \leq 1$
- $\frac{Pn385 \text{ [100 mm/s]}}{\text{Linear encoder pitch [\mu m]}} \times \frac{\text{Resolution of Serial Converter Unit}}{\text{Approx. } 6.10 \times 10^5} \geq 1$

Fig. 382: Formulae Detection conditions - Linear Servomotor

*2. Refer to the following manual for details.

📖 Σ -7-Series AC Servo Drive Peripheral Device Selection Manual (Manual No.: SIEP S800001 32)

*3. The SERVOPACK will fail if the External Regenerative Resistor or Regenerative Resistor Unit is connected while the jumper is connected between the B2 and B3 terminals.

*4. These alarms are not stored in the alarm history. They are only displayed on the panel display.

16.4.4 Resetting Alarms

If there is an ALM (Servo Alarm) signal, use one of the following methods to reset the alarm after eliminating the cause of the alarm.



Be sure to eliminate the cause of an alarm before you reset the alarm. If you reset the alarm and continue operation without eliminating the cause of the alarm, it may result in damage to the equipment or fire.

Clearing Alarms and Warnings with the Fault Reset Command

Execute the Fault Reset command to clear alarms or warnings.

Refer to the following section for details on the Fault Reset command.

➔ [Chap. 15.6 'Device Control' ...page 512](#)

Resetting Alarms Using the Digital Operator

Press the **ALARM RESET** Key on the Digital Operator. Refer to the following manual for details on resetting alarms.

📖 [Σ-7-Series Digital Operator Operating Manual \(Manual No.: SIEP S800001 33\)](#)

16.4.5 Displaying the Alarm History

The alarm history displays up to the last ten alarms that have occurred in the SERVOPACK.



The following alarms are not displayed in the alarm history: FL-1 to FL-6.

Preparations

No preparations are required.


Applicable Tools

The following table lists the tools that you can use to display the alarm history and the applicable tool functions.

Tool	Function	Reference
Digital Operator	Fn000	📖 Σ-7-Series Digital Operator Operating Manual (Manual No.: SIEP S800001 33)
SigmaWin+	<i>Alarm – Display Alarm</i>	➔ 'Operating Procedure' ...page 594

Operating Procedure

Use the following procedure to display the alarm history.

1. Click the  Servo Drive Button in the workspace of the Main Window of the SigmaWin+.
2. Select Display Alarm in the Menu Dialog Box.
The Alarm Display Dialog Box will be displayed.
3. Click the Alarm History Tab.
The following display will appear and you can check the alarms that occurred in the past.

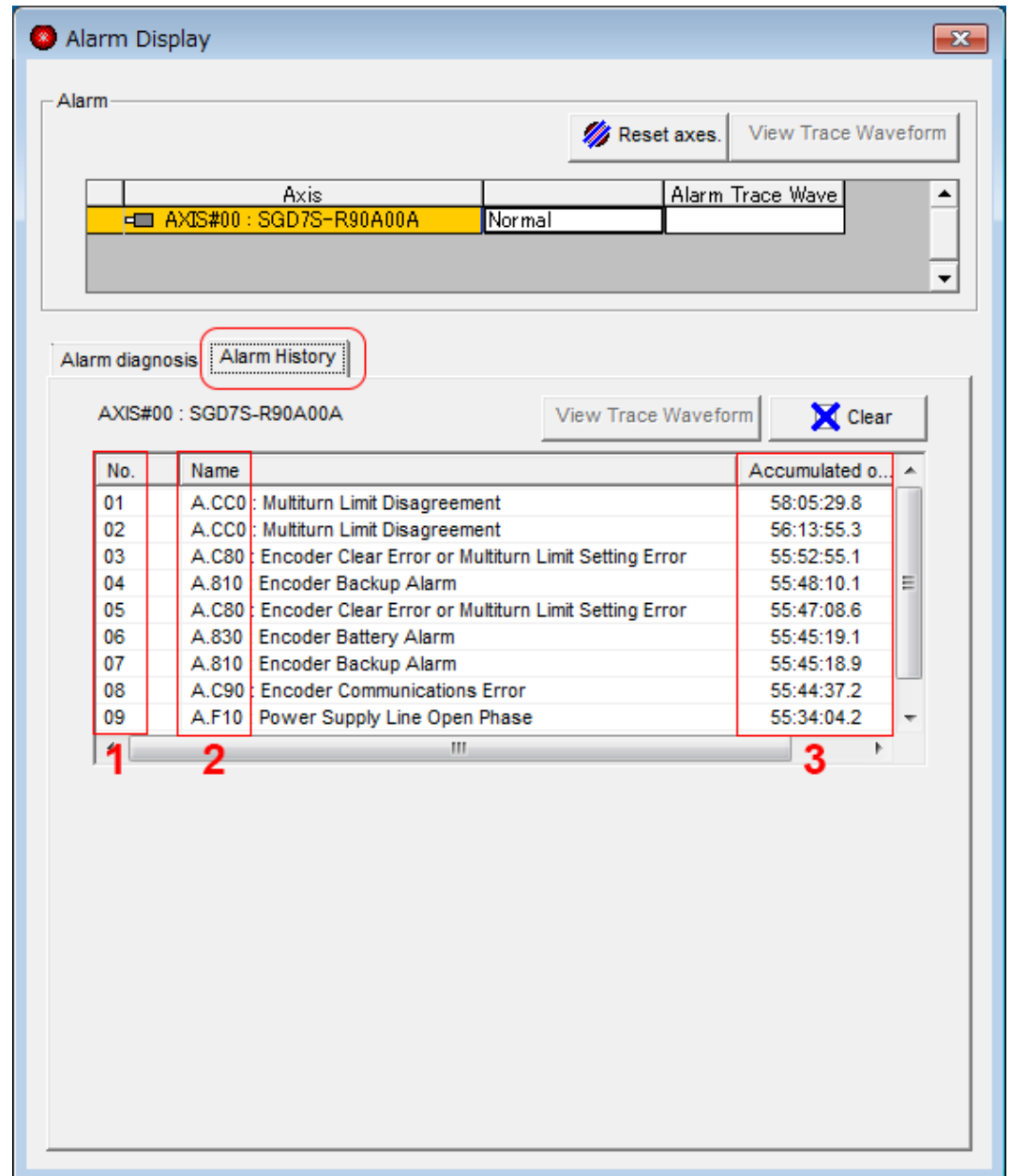


Fig. 383: Alarm Display - Alarm History Tab

- 1 Alarms in order of occurrence (older alarms have higher numbers.)
- 2 Alarm number: Alarm name
- 3 Accumulated operation time
Total operation time to the point at which the alarm occurred is displayed in increments of 100 ms from when the control power supply and main circuit power supply turned ON.
For 24-hour, 365-day operation, measurements are possible for approximately 13 years.

This concludes the procedure to display the alarm history.

16.4.6 Clearing the Alarm History

You can clear the alarm history that is recorded in the SERVOPACK.

The alarm history is not cleared when alarms are reset or when the SERVOPACK main circuit power is turned OFF. You must perform the following procedure.


Preparations

Always check the following before you clear the alarm history.

- The parameters must not be write prohibited.





Applicable Tools

The following table lists the tools that you can use to clear the alarm history and the applicable tool functions.

Tool	Function	Reference
Digital Operator	Fn006	 Σ -7-Series Digital Operator Operating Manual (Manual No.: SIEP S800001 33)
SigmaWin+	<i>Alarm – Display Alarm</i>	↪ ‘Operating Procedure’ ...page 596

Operating Procedure

Use the following procedure to reset the alarm history.

1.  Click the  Servo Drive Button in the workspace of the Main Window of the SigmaWin+.
2.  Select Display Alarm in the Menu Dialog Box.
The Alarm Display Dialog Box will be displayed.
3.  Click the Alarm History Tab.

4. Click the Clear Button.

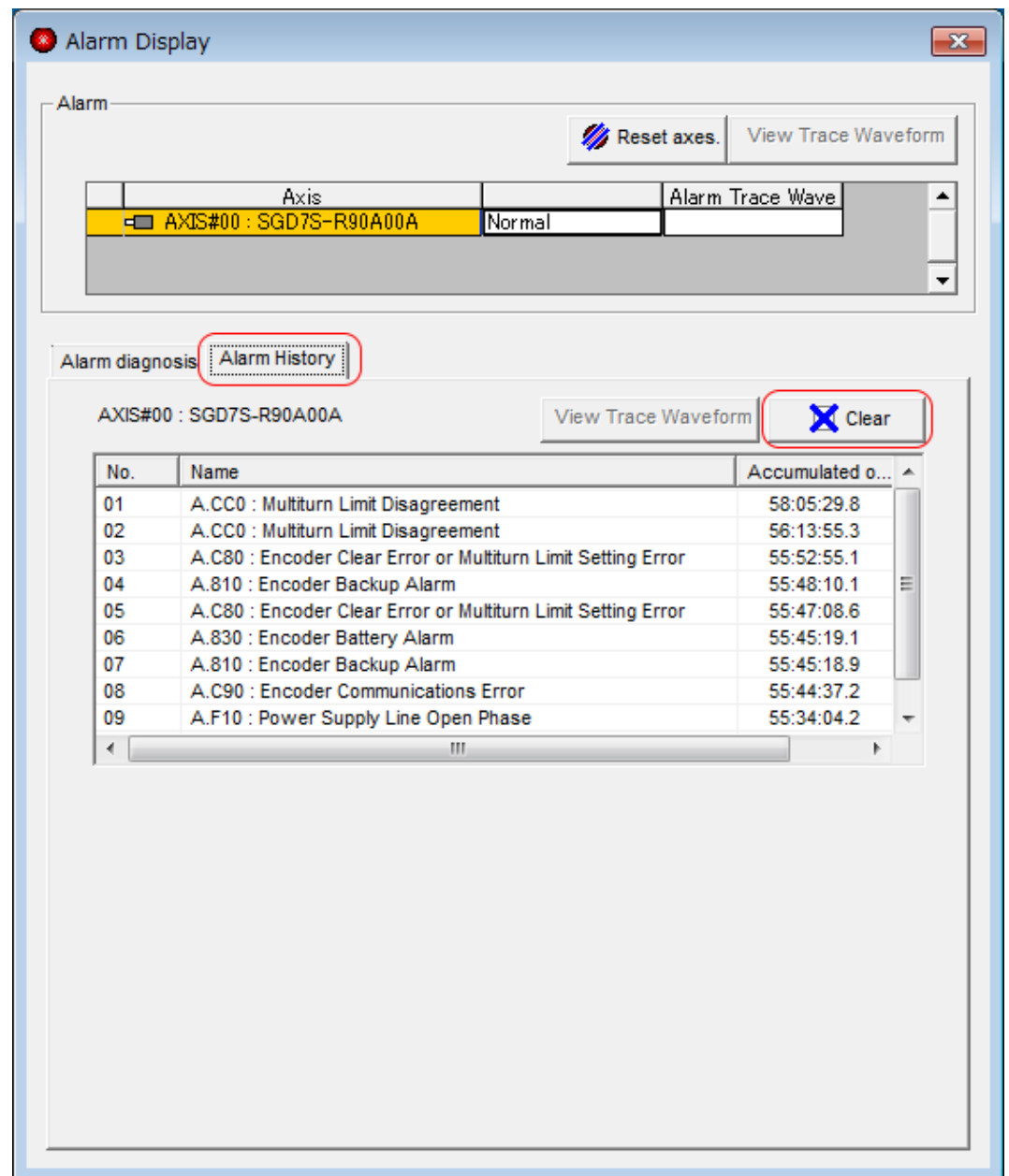


Fig. 384: Alarm Display - Clear Alarm History

➔ The alarm history will be cleared.

This concludes the procedure to reset the alarm history.

16.4.7 Resetting Alarms Detected in Option Modules

If any Option Modules are attached to the SERVOPACK, the SERVOPACK detects the presence and models of the connected Option Modules. If it finds any errors, it outputs alarms.

You can delete those alarms with this operation.



- This operation is the only way to reset alarms for Option Modules. The alarms are not reset when you reset other alarms or when you turn OFF the power supply to the SERVOPACK.
- Always remove the cause of an alarm before you reset the alarm.

Preparations

Always check the following before you clear an alarm detected in an Option Module.

- The parameters must not be write prohibited.


Applicable Tools

The following table lists the tools that you can use to reset Option Module configuration errors and the applicable tool functions.

Tool	Function	Reference
Digital Operator	Fn014	Σ-7-Series Digital Operator Operating Manual (Manual No.: SIEP S800001 33)
SigmaWin+	Setup – Reset Configuration Error of Option Module	→ ‘Operating Procedure’ ...page 598

Operating Procedure

Use the following procedure to reset alarms detected in Option Modules.

1. Click the  Servo Drive Button in the workspace of the Main Window of the SigmaWin+.
2. Select Reset Option Module Configuration Error in the Menu Dialog Box. The Reset Option Module Configuration Error Dialog Box will be displayed.
3. Select the Clear Check Box for the Option Modules from which to clear alarms and then click the Execute Button.

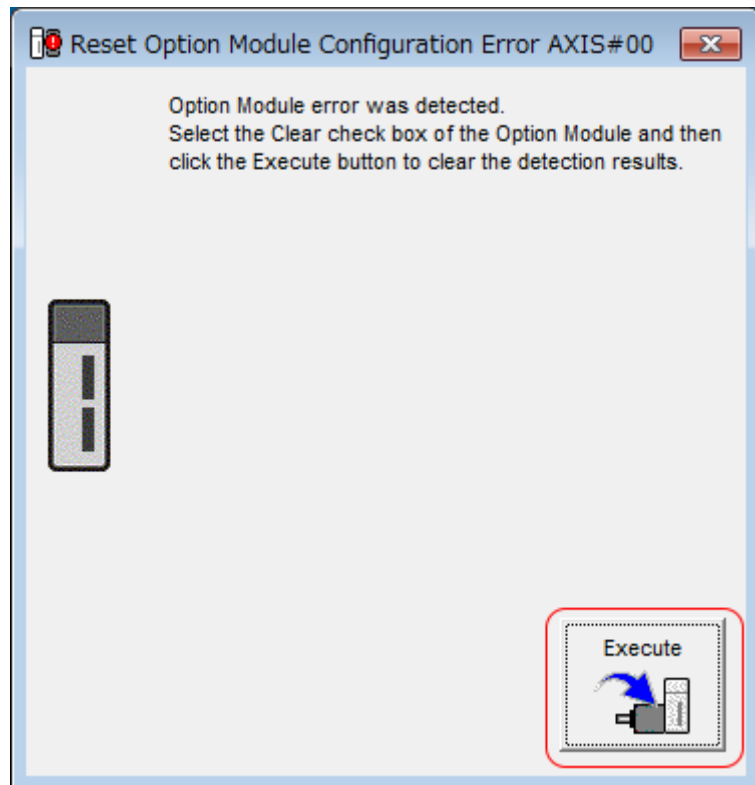


Fig. 385: Reset Option Module Configuration Error AXIS#00

4. Click the OK Button.

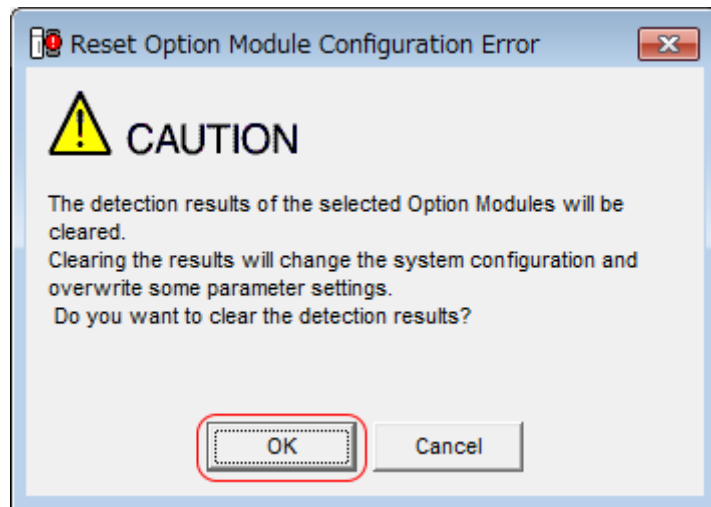


Fig. 386: Reset Option Module Configuration Error - Caution - Clearing Detection Results - OK Button

5. Click the OK Button.

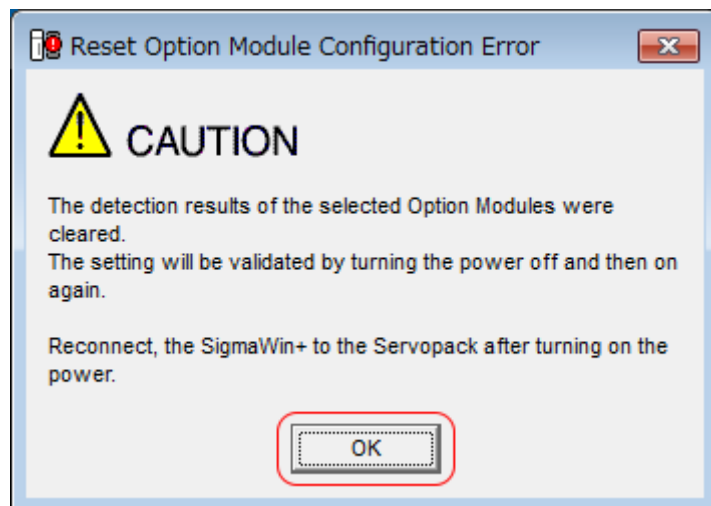


Fig. 387: Reset Option Module Configuration Error - Caution - Clearing Detection Results - OK Button Step 2

6. Turn the power supply to the SERVOPACK OFF and ON again.

This concludes the procedure to reset alarms detected in Option Modules.

16.4.8 Resetting Motor Type Alarms

The SERVOPACK automatically determines the type of Servomotor that is connected to it. If the type of Servomotor that is connected is changed, an A.070 alarm (Motor Type Change Detected) will occur the next time the SERVOPACK is started. If an A.070 alarm occurs, you must set the parameters to match the new type of Servomotor.

An A.070 alarm is reset by executing the Reset Motor Type Alarm utility function.



- This utility function is the only way to reset an A.070 alarm (Motor Type Change Detected). The errors are not reset when you reset alarms or turn OFF the power supply to the SERVOPACK.
- If an A.070 alarm occurs, first set the parameters according to the newly connected Servomotor type and then execute the Reset Motor Type Alarm utility function.

Preparations

Always check the following before you clear a motor type alarm.

- The parameters must not be write prohibited.

Applicable Tools

The following table lists the tools that you can use to clear the motor type alarm and the applicable tool functions.

Tool	Function	Reference
Digital Operator	Fn021	Σ-7-Series Digital Operator Operating Manual (Manual No.: SIEP S800001 33)
SigmaWin+	Alarm – Reset Motor Type Alarm	→ ‘Operating Procedure’ ...page 600

Operating Procedure

Use the following procedure to reset Motor Type alarm.

1. Click the Servo Drive Button in the workspace of the Main Window of the SigmaWin+.
2. Select Reset Motor Type Alarm in the Menu Dialog Box.
 - ➔ The Reset Motor Type Alarm Dialog Box will be displayed.
3. Click the Clear Button.
 - ➔ The alarm will be cleared.

This concludes the procedure to reset Motor Type alarms.

16.5 Warning Displays

16.5.1 General

To check a warning that occurs in the SERVOPACK, use one of the following methods. Warnings are displayed to warn you before an alarm occurs.

Panel display on SERVOPACK	<p>If there is a warning, the code will be displayed one character at a time, as shown below.</p> <p>Example: A.910</p>
SigmaWin+ Servo Information Display	<p>The warning code will be displayed.</p> <p>Example: A.910</p>
Digital Operator	<p>The warning code is displayed.</p> <p>Example: A.910</p>

Statusword (6041h)	Bit 7 (warning) in the statusword will change to 1. (Bit 7 is 0 during normal operation.)
Error Code (603Fh)	A current warning code is stored in error code (603Fh). Example: 1910h
Emergency message	The IO-Controller is notified of any warning that occurs. (Notification may not be possible if PROFINET communications are unstable.) Example: 1910h

The next section provides a list of warnings and the causes of and corrections for warnings.

16.5.2 List of Warnings

16.5.2.1 Overview



The object Error Code (603Fh) provides the error code of the last alarm/warning which occurred in the drive device. The value of object Error Code (603Fh) is not reset until the alarm/warning has been acknowledged and no alarm or warning is present.

16.5.2.2 List of the PROFINET Module Warnings

The following warning table gives the warning name and warning meaning in order of the warning codes.

Warning Code	Warning Name	Meaning
A.A91 (1A91h)	Invalid Cyclic Data	Wrong Value Received from IO-Controller Via PZDO.

16.5.2.3 List of the SERVOPACK Warnings

The following warning table gives the warning name and warning meaning in order of the warning codes.

Warning Code	Warning Name	Meaning
A.900 (1900h)	Position Deviation Overflow	The position deviation exceeded the percentage set with the following formula: $(Pn520 \times Pn51E/100)$
A.901 (1901h)	Position Deviation Overflow Alarm at Servo ON	The position deviation when the servo was turned ON exceeded the percentage set with the following formula: $(Pn526 \times Pn528/100)$
A.910 (1910h)	Overload	This warning occurs before an overload alarm (A.710 or A.720) occurs. If the warning is ignored and operation is continued, an alarm may occur.
A.911 (1911h)	Vibration	Abnormal vibration was detected during motor operation. The detection level is the same as A.520. Set whether to output an alarm or a warning by setting Pn310 (Vibration Detection Selections).
A.912 (1912h)	Internal Temperature Warning 1 (Control Board Temperature Error)	The surrounding temperature of the control PCB is abnormal.

Warning Code	Warning Name	Meaning
A.913 (1913h)	Internal Temperature Warning 2 (Power Board Temperature Error)	The surrounding temperature of the power PCB is abnormal.
A.920 (1920h)	Regenerative Overload	This warning occurs before an A.320 alarm (Regenerative Overload) occurs. If the warning is ignored and operation is continued, an alarm may occur.
A.921 (1921h)	Dynamic Brake Overload	This warning occurs before an A.731 alarm (Dynamic Brake Overload) occurs. If the warning is ignored and operation is continued, an alarm may occur.
A.923 (1923h)	SERVOPACK Built-in Fan Stopped	The fan inside the SERVOPACK stopped.
A.930 (1930h)	Absolute Encoder Battery Error	This warning occurs when the voltage of absolute encoder's battery is low.
A.93B (193Bh)	Overheat Warning	The input voltage (temperature) for the overheat protection input (TH) signal exceeded the setting of Pn61C (Overheat Warning Level).
A.942 (1942h)	Speed Ripple Compensation Information Disagreement	The speed ripple compensation information stored in the encoder does not agree with the speed ripple compensation information stored in the SERVOPACK.
A.971 (1971h)	Undervoltage	This warning occurs before an A.410 alarm (Undervoltage) occurs. If the warning is ignored and operation is continued, an alarm may occur.
A.9A0 (19A0h)	Overtravel	Overtravel was detected while the servo was ON.
A.9b0 (19b0h)	Preventative Maintenance Warning	One of the consumable parts has reached the end of its service life.



Use Pn008 = n.□X□□ (Warning Detection Selection) to control warning detection.

However, the following warnings are not affected by the setting of Pn008 = n.□X□□.

Warning Code	Parameters That Must Be Set to Select Warning Detection	Reference
A.971 (1971h)	Pn008 = n.□□X□ (Function Selection for Undervoltage)	↪ Chap. 7.4 'SEMI F47 Function' ...page 201
A.9A0 (19A0h)	Pn00D = n.X□□□ (Overtravel Warning Detection Selection)	↪ Chap. 6.11.5 'Overtravel Warnings' ...page 158

In addition to Pn008 = n.□X□□, the following parameters must also be set.

Warning Code	Parameters That Must Be Set to Select Warning Detection	Reference
A.911 (1911h)	Pn310 = n.□□□X (Vibration Detection Selections)	↪ Chap. 7.12.1 'Initializing the Vibration Detection Level' ...page 236
A.930 (1930h)	Pn008 = n.□□□X (Low Battery Voltage Alarm/Warning Selection)	↪ Chap. 16.2.4 'Replacing the Battery' ...page 547
A.942 (1942h)	Pn423 = n.□□X□ (Speed Ripple Compensation Information Disagreement Warning Detection Selection)	↪ Chap. 9.12.1 'Speed Ripple Compensation' ...page 361
A.9b0 (19b0h)	Pn00F = n.□□□X (Preventative Maintenance Warning Selection)	↪ Chap. 10.5.3 'Preventative Maintenance' ...page 426

16.5.3 Troubleshooting Warnings

16.5.3.1 Overview

The causes of and corrections for the warnings are given in the following table. Contact your YASKAWA representative if you cannot solve a problem with the correction given in the table.

16.5.3.2 Troubleshooting of the PROFINET Module Warnings

Warning Code	Warning Name	Possible Cause	Confirmation	Correction	Reference
A.A91 (1A91h)	Invalid Cyclic Data	The process data sent from IO-Controller contains invalid data.	Check the process data sent by the IO-Controller.	Correct cyclic set-point data and send command fault acknowledge to release the warning.	–

16.5.3.3 Troubleshooting of the SERVOPACK Warnings

Warning Code	Warning Name	Possible Cause	Confirmation	Correction	Reference
A.900 (1900h)	Position Deviation Overflow	The Servomotor U, V, and W wiring is not correct.	Check the wiring of the Servomotor's Main Circuit Cables.	Make sure that there are no faulty connections in the wiring for the Servomotor and encoder.	–
		A SERVOPACK gain is too low.	Check the SERVOPACK gains.	Increase the servo gain, e.g., by using autotuning without a host reference.	↪ Chap. 9.7.1 'Autotuning without Host Reference' ...page 306
		The acceleration of the position reference is too high.	Reduce the reference acceleration and try operating the SERVOPACK.	Reduce the acceleration of the position reference using a PROFINET command.	–
		The excessive position deviation alarm level (Pn520 × Pn51E/100) is too low for the operating conditions.	Check excessive position deviation alarm level (Pn520 × Pn51E/100) to see if it is set to an appropriate value.	Optimize the settings of Pn520 and Pn51E.	↪ Chap. 9.4.1 'Precautions to Ensure Safe Tuning' ...page 286
		A failure occurred in the SERVOPACK.	–	Turn the power supply to the SERVOPACK OFF and ON again. If an alarm still occurs, the SERVOPACK may be faulty. Replace the SERVOPACK.	–

Warning Code	Warning Name	Possible Cause	Confirmation	Correction	Reference
A.901 (1901h)	Position Deviation Overflow Alarm at Servo ON	The position deviation when the servo was turned ON exceeded the percentage set with the following formula: $(Pn526 \times Pn528/100)$	–	Optimize the setting of Pn528 (Position Deviation Overflow Warning Level at Servo ON).	–
A.910 (1910h)	Overload (warning before an A.710 or A.720 alarm occurs)	The wiring is not correct or there is a faulty connection in the motor or encoder wiring.	Check the wiring.	Make sure that the Servomotor and encoder are correctly wired.	–
		Operation was performed that exceeded the overload protection characteristics.	Check the motor overload characteristics and Run command.	Reconsider the load and operating conditions. Or, increase the motor capacity.	–
		An excessive load was applied during operation because the Servomotor was not driven because of mechanical problems.	Check the operation reference and motor speed.	Remove the mechanical problem.	–
		The overload warning level (Pn52B) is not suitable.	Check that the overload warning level (Pn52B) is suitable.	Set a suitable overload warning level (Pn52B).	↪ Chap. 6.14.1 'Motor Overload Detection Level' ...page 170
		A failure occurred in the SERVOPACK.	–	The SERVOPACK may be faulty. Replace the SERVOPACK.	–
A.911 (1911h)	Vibration	Abnormal vibration was detected during motor operation.	Check for abnormal motor noise, and check the speed and torque waveforms during operation.	Reduce the motor speed. Or, reduce the servo gain with custom tuning.	↪ Chap. 9.9.1 'Custom Tuning' ...page 332
		The setting of Pn103 (Moment of Inertia Ratio) is greater than the actual moment of inertia or was greatly changed.	Check the moment of inertia ratio or mass ratio.	Correct the setting of Pn103.	↪ Chap. 9.6.1 'Estimating the Moment of Inertia' ...page 295
		The vibration detection level (Pn312 or Pn384) is not suitable.	Check that the vibration detection level (Pn312 or Pn384) is suitable.	Set a suitable vibration detection level (Pn312 or Pn384).	↪ Chap. 7.12.1 'Initializing the Vibration Detection Level' ...page 236

Warning Code	Warning Name	Possible Cause	Confirmation	Correction	Reference
A.912 (1912h)	Internal Temperature Warning 1 (Control Board Temperature Error)	The surrounding temperature is too high.	Check the surrounding temperature using a thermometer. Or, check the operating status with the SERVOPACK installation environment monitor.	Decrease the surrounding temperature by improving the SERVOPACK installation conditions.	→ Chap. 4.6 'Monitoring the Installation Environment' ...page 79
		An overload alarm was reset by turning OFF the power supply too many times.	Check the alarm display to see if there is an overload alarm.	Change the method for resetting the alarm.	–
		There was an excessive load or operation was performed that exceeded the regenerative processing capacity.	Use the accumulated load ratio to check the load during operation, and use the regenerative load ratio to check the regenerative processing capacity.	Reconsider the load and operating conditions.	–
		The SERVOPACK installation orientation is not correct or there is insufficient space around the SERVOPACK.	Check the SERVOPACK installation conditions.	Install the SERVOPACK according to specifications.	→ Chap. 4.3 'Mounting Types and Orientation' ...page 74 , → Chap. 4.5.1 'Mounting Interval' ...page 78
		A failure occurred in the SERVOPACK.	–	The SERVOPACK may be faulty. Replace the SERVOPACK.	–
A.913 (1913h)	Internal Temperature Warning 2 (Power Board Temperature Error)	The surrounding temperature is too high.	Check the surrounding temperature using a thermometer. Or, check the operating status with the SERVOPACK installation environment monitor.	Decrease the surrounding temperature by improving the SERVOPACK installation conditions.	→ Chap. 4.6 'Monitoring the Installation Environment' ...page 79
		An overload alarm was reset by turning OFF the power supply too many times.	Check the alarm display to see if there is an overload alarm.	Change the method for resetting the alarm.	–
		There was an excessive load or operation was performed that exceeded the regenerative processing capacity.	Use the accumulated load ratio to check the load during operation, and use the regenerative load ratio to check the regenerative processing capacity.	Reconsider the load and operating conditions.	–

Warning Code	Warning Name	Possible Cause	Confirmation	Correction	Reference
		The SERVOPACK installation orientation is not correct or there is insufficient space around the SERVOPACK.	Check the SERVOPACK installation conditions.	Install the SERVOPACK according to specifications.	→ Chap. 4.3 'Mounting Types and Orientation' ...page 74, → Chap. 4.5.1 'Mounting Interval' ...page 78
		A failure occurred in the SERVOPACK.	–	The SERVOPACK may be faulty. Replace the SERVOPACK.	–
A.920 (1920h)	Regenerative Overload (warning before an A.320 alarm occurs)	The power supply voltage exceeded the specified range.	Measure the power supply voltage.	Set the power supply voltage within the specified range.	–
		There is insufficient external regenerative resistance, regenerative resistor capacity, or SERVOPACK capacity, or there has been a continuous regeneration state.	Check the operating conditions or the capacity using the SigmaJunmaSize+ Capacity Selection Software or another means.	Change the regenerative resistance value, regenerative resistance capacity, or SERVOPACK capacity. Reconsider the operating conditions using the Sigma- JunmaSize+ Capacity Selection Software or other means.	–
		There was a continuous regeneration state because a negative load was continuously applied.	Check the load applied to the Servomotor during operation.	Reconsider the system including the servo, machine, and operating conditions.	–
A.921 (1921h)	Dynamic Brake Overload (warning before an A.731 alarm occurs)	The Servomotor was rotated by an external force.	Check the operation status.	Implement measures to ensure that the motor will not be rotated by an external force.	–
		When the Servomotor was stopped with the dynamic brake, the rotational or linear kinetic energy exceeded the capacity of the dynamic brake resistor.	Check the power consumed by the DB resistor to see how frequently the DB is being used.	Reconsider the following: <ul style="list-style-type: none"> ■ Reduce the Servomotor command speed. ■ Decrease the moment of inertia or mass. ■ Reduce the frequency of stopping with the dynamic brake. 	–
		A failure occurred in the SERVOPACK.	–	The SERVOPACK may be faulty. Replace the SERVOPACK.	–

Warning Code	Warning Name	Possible Cause	Confirmation	Correction	Reference
A.923 (1923h)	SERVOPACK Built-in Fan Stopped	The fan inside the SERVOPACK stopped.	Check for foreign matter inside the SERVOPACK.	Remove foreign matter from the SERVOPACK. If the alarm still occurs, the SERVOPACK may be faulty. Replace the SERVOPACK.	–
A.930 (1930h)	Absolute Encoder Battery Error (The absolute encoder battery voltage was lower than the specified level.) (Detected only when an absolute encoder is connected.)	The battery connection is faulty or a battery is not connected.	Check the battery connection.	Correct the battery connection.	↪ Chap. 5.5.3.1 'Wiring the SERVOPACK to the Encoder' ...page 106
		The battery voltage is lower than the specified value (2.7 V).	Measure the battery voltage.	Replace the battery.	↪ Chap. 16.2.4 'Replacing the Battery' ...page 547
		A failure occurred in the SERVOPACK.	–	The SERVOPACK may be faulty. Replace the SERVOPACK.	–
A.93B (193Bh)	Overheat Warning	The surrounding temperature is too high.	Check the surrounding temperature using a thermometer.	Lower the surrounding temperature by improving the installation conditions of the Linear Servomotor or the machine.	–
		Operation was performed under an excessive load.	Use the accumulated load ratio to check the load during operation.	Reconsider the load and operating conditions.	–
		A failure occurred in the SERVOPACK.	–	The SERVOPACK may be faulty. Replace the SERVOPACK.	–
		The temperature detection circuit in the Linear Servomotor is faulty or the sensor attached to the machine is faulty.	–	The temperature detection circuit in the Linear Servomotor may be faulty or the sensor attached to the machine may be faulty. Replace the Linear Servomotor or repair the sensor attached to the machine.	–
A.942 (1942h)	Speed Ripple Compensation Information Disagreement	The speed ripple compensation information stored in the encoder does not agree with the speed ripple compensation information stored in the SERVOPACK.	–	Reset the speed ripple compensation value on the SigmaWin+.	↪ Chap. 9.12.1 'Speed Ripple Compensation' ...page 361

Warning Code	Warning Name	Possible Cause	Confirmation	Correction	Reference
			–	Set Pn423 to n.□□1□ (Do not detect A.942 alarms). However, changing the setting may increase the speed ripple.	↪ Chap. 9.12.1 'Speed Ripple Compensation' ...page 361
			–	Set Pn423 to n.□□□0 (Disable speed ripple compensation). However, changing the setting may increase the speed ripple.	↪ Chap. 9.12.1 'Speed Ripple Compensation' ...page 361
A.971 (1971h)	Undervoltage	For a 200-V SERVOPACK, the AC power supply voltage dropped below 140 V.	Measure the power supply voltage.	Set the power supply voltage within the specified range.	–
		For a 100-V SERVOPACK, the AC power supply voltage dropped below 60 V.	Measure the power supply voltage.	Set the power supply voltage within the specified range.	–
		The power supply voltage dropped during operation.	Measure the power supply voltage.	Increase the power supply capacity.	–
		A momentary power interruption occurred.	Measure the power supply voltage.	If you have changed the setting of Pn509 (Momentary Power Interruption Hold Time), decrease the setting.	↪ Chap. 7.3 'Operation for Momentary Power Interruptions' ...page 200
		The SERVOPACK fuse is blown out.	–	Replace the SERVOPACK and connect a reactor.	↪ Chap. 5.4.7 'Wiring Reactors for Harmonic Suppression' ...page 104
		A failure occurred in the SERVOPACK.	–	The SERVOPACK may be faulty. Replace the SERVOPACK.	–

Troubleshooting Based on the Operation and Conditions of the Servomotor

Warning Code	Warning Name	Possible Cause	Confirmation	Correction	Reference
A.9A0 (19A0h)	Overtravel (Overtravel status was detected.)	Overtravel was detected while the servo was ON.	Check the status of the overtravel signals on the input signal monitor.	<p>Even if an overtravel signal is not shown by the input signal monitor, momentary overtravel may have been detected. Take the following precautions.</p> <ul style="list-style-type: none"> ■ Do not specify movements that would cause overtravel from the host controller. ■ Check the wiring of the overtravel signals. ■ Implement countermeasures against noise. 	<p>↪ Chap. 6.11.5 'Overtravel Warnings' ...page 158</p>
A.9b0 (19b0h)	Preventative Maintenance Warning	One of the consumable parts has reached the end of its service life.	–	Replace the part. Contact your YASKAWA representative for replacement.	<p>↪ Chap. 10.5.2 'Operating Procedure' ...page 425</p>

16.6 Troubleshooting Based on the Operation and Conditions of the Servomotor

This section provides troubleshooting based on the operation and conditions of the Servomotor, including causes and corrections.

Problem	Possible Cause	Confirmation	Correction	Reference
Servomotor Does Not Start	The control power supply is not turned ON.	Measure the voltage between control power supply terminals.	Turn OFF the power supply to the servo system. Correct the wiring so that the control power supply is turned ON.	–
	The main circuit power supply is not turned ON.	Measure the voltage across the main circuit power input terminals.	Turn OFF the power supply to the servo system. Correct the wiring so that the main circuit power supply is turned ON.	–
	The I/O signal connector (CN1) pins are not wired correctly or are disconnected.	Turn OFF the power supply to the servo system. Check the wiring condition of the I/O signal connector (CN1) pins.	Correct the wiring of the I/O signal connector (CN1) pins.	<p>↪ Chap. 5.6.1 'Connecting I/O Signals' ...page 114, ↪ Chap. 10.3.3 'I/O Signal Monitor' ...page 414</p>
	The wiring for the Servomotor Main Circuit Cables or Encoder Cable is disconnected.	Check the wiring conditions.	Turn OFF the power supply to the servo system. Wire the cable correctly.	–

Troubleshooting Based on the Operation and Conditions of the Servomotor

Problem	Possible Cause	Confirmation	Correction	Reference
	There is an overload on the Servomotor.	Operate the Servomotor with no load and check the load status.	Turn OFF the power supply to the servo system. Reduce the load or replace the Servomotor with a Servomotor with a larger capacity.	–
	The type of encoder that is being used does not agree with the setting of Pn002 = n.X□□ (Encoder Usage).	Check the type of the encoder that is being used and the setting of Pn002 = n.X□□.	Set Pn002 = n.X□□ according to the type of the encoder that is being used.	→ Chap. 7.9.1 'Absolute Encoders' ...page 218
	There is a mistake in the input signal allocations (Pn50A, Pn50B, Pn511, and Pn516).	Check the input signal allocations (Pn50A, Pn50B, Pn511, Pn516).	Correctly allocate the input signals (Pn50A, Pn50B, Pn511, Pn516).	→ Chap. 7.2.1 'I/O Signal Allocations' ...page 189, → Chap. 10.3.3 'I/O Signal Monitor' ...page 414
	The Servo ON command (Enable Operation command) was not sent.	Make sure the Servo ON command (Enable Operation command) is set to Operation Enabled.	Set the correct value for the Servo ON command (Enable Operation command).	–
	The torque limit reference is too small.	Check the torque limit reference.	Increase the torque limit reference.	–
	The operation mode is not set.	Check to see if <i>Modes of Operation</i> (6060h) is set.	Set <i>Modes of Operation</i> (6060h) correctly.	–
	A software limit is active.	Check to see if the target position exceeds a software limit.	Specify a target position that is within the software limits.	–
	PROFINET communications are not established.	Check to see if the PROFINET indicator shows that the IO-Controller is in RUN mode.	Place the IO-Controller in RUN mode.	–
	The P-OT (Forward Drive Prohibit) or N-OT (Reverse Drive Prohibit) signal is still OFF.	Check the P-OT and N-OT signals.	Turn ON the P-OT and N-OT signals.	→ Chap. 10.3.3 'I/O Signal Monitor' ...page 414
	The safety input signals (/HWBB1 or /HWBB2) were not turned ON.	Check the /HWBB1 and /HWBB2 input signals.	Turn ON the /HWBB1 and /HWBB2 input signals. If you are not using the safety function, connect the Safety Jumper Connector (provided as an accessory) to CN8.	→ Chap. 10.3.3 'I/O Signal Monitor' ...page 414

Troubleshooting Based on the Operation and Conditions of the Servomotor

Problem	Possible Cause	Confirmation	Correction	Reference
	The FSTP (Forced Stop Input) signal is still OFF.	Check the FSTP signal.	<ul style="list-style-type: none"> Turn ON the FSTP signal. If you will not use the function to force the motor to stop, set Pn516 = n.□□□X (FSTP (Forced Stop Input) Signal Allocation) to disable the signal. 	→ Chap. 10.3.3 'I/O Signal Monitor' ...page 414
	A failure occurred in the SERVOPACK.	–	Turn OFF the power supply to the servo system. Replace the SERVOPACK.	–
	The polarity detection was not executed.	Check the setting of Pn080 = n.□□□X (Polarity Sensor Selection).	Correct the parameter setting.	→ Chap. 6.9 'Polarity Sensor Setting' ...page 152
		Check the inputs to the Servo ON command (Enable Operation command).	<ul style="list-style-type: none"> If you are using an incremental linear encoder, send the Servo ON command (Enable Operation command) from the host controller. If you are using an absolute linear encoder, execute polarity detection. 	→ Chap. 6.10.1 'Polarity Detection' ...page 152
Servomotor Moves Instantaneously, and Then Stops	There is a mistake in the Servomotor wiring.	Turn OFF the power supply to the servo system. Check the wiring.	Wire the Servomotor correctly.	–
	There is a mistake in the wiring of the encoder or Serial Converter Unit.	Turn OFF the power supply to the servo system. Check the wiring.	Wire the Serial Converter Unit correctly.	–
	There is a mistake in the linear encoder wiring.	Turn OFF the power supply to the servo system. Check the wiring.	Wire the cable correctly.	–
	The setting of Pn282 (Linear Encoder Pitch) is not correct.	Check the setting of Pn282.	Correct the setting of Pn282.	→ Chap. 6.6 'Setting the Linear Encoder Pitch' ...page 142
	The count-up direction of the linear encoder does not match the forward direction of the Moving Coil in the motor.	Check the directions.	Change the setting of Pn080 = n.□□X□ (Motor Phase Selection). Match the linear encoder direction and motor direction.	→ Chap. 6.8 'Selecting the Phase Sequence for a Linear Servomotor' ...page 150

Troubleshooting Based on the Operation and Conditions of the Servomotor

Problem	Possible Cause	Confirmation	Correction	Reference
	Polarity detection was not performed correctly.	Check to see if electrical angle 2 (electrical angle from polarity origin) at any position is between $\pm 10^\circ$.	Correct the settings for the polarity detection-related parameters.	–
Servomotor Speed Is Unstable	There is a faulty connection in the Servomotor wiring.	The connector connections for the power line (U, V, and W phases) and the encoder or Serial Converter Unit may be unstable. Turn OFF the power supply to the servo system. Check the wiring.	Tighten any loose terminals or connectors and correct the wiring.	–
Servomotor Moves without a Reference Input	A failure occurred in the SERVOPACK.	–	Turn OFF the power supply to the servo system. Replace the SERVOPACK.	–
	The count-up direction of the linear encoder does not match the forward direction of the Moving Coil in the motor.	Check the directions.	Change the setting of Pn080 = n.□□X□ (Motor Phase Selection). Match the linear encoder direction and Servomotor direction.	↪ Chap. 6.8 'Selecting the Phase Sequence for a Linear Servomotor' ...page 150
	Polarity detection was not performed correctly.	Check to see if electrical angle 2 (electrical angle from polarity origin) at any position is between $\pm 10^\circ$.	Correct the settings for the polarity detection-related parameters.	–
Dynamic Brake Does Not Operate	The setting of Pn001 = n.□□□X (Motor Stopping Method for Servo OFF and Group 1 Alarms, Overtravel Stopping Method) is not suitable.	Check the setting of Pn001 = n.□□□X.	Set Pn001 = n.□□□X correctly.	–
	The dynamic brake resistor is disconnected.	Check the moment of inertia, motor speed, and dynamic brake frequency of use. If the moment of inertia, motor speed, or dynamic brake frequency of use is excessive, the dynamic brake resistance may be disconnected.	Turn OFF the power supply to the servo system. Replace the SERVOPACK. To prevent disconnection, reduce the load.	–

Troubleshooting Based on the Operation and Conditions of the Servomotor

Problem	Possible Cause	Confirmation	Correction	Reference
	There was a failure in the dynamic brake drive circuit.	–	There is a defective component in the dynamic brake circuit. Turn OFF the power supply to the servo system. Replace the SERVOPACK.	–
Abnormal Noise from Servomotor	The Servomotor vibrated considerably while performing the tuning-less function with the default settings.	Check the waveform of the motor speed.	Reduce the load so that the moment of inertia ratio or mass ratio is within the allowable value, or increase the load level or reduce the rigidity level in the tuning-less level settings. If the situation is not improved, disable the tuning-less function (i.e., set Pn170 to n.□□□0) and execute autotuning either with or without a host reference.	↪ Chap. 9.5.1 'Tuning-less Function' ...page 290
	The machine mounting is not secure.	Turn OFF the power supply to the servo system. Check to see if there are any loose mounting screws.	Tighten the mounting screws.	–
	The machine mounting is not secure.	Turn OFF the power supply to the servo system. Check to see if there is misalignment in the coupling.	Align the coupling.	–
		Turn OFF the power supply to the servo system. Check to see if the coupling is balanced.	Balance the coupling.	–
	The bearings are defective.	Turn OFF the power supply to the servo system. Check for noise and vibration around the bearings.	Replace the Servomotor.	–
There is a vibration source at the driven machine.	Turn OFF the power supply to the servo system. Check for any foreign matter, damage, or deformation in the machine's moving parts.	Consult with the machine manufacturer.	–	

Troubleshooting Based on the Operation and Conditions of the Servomotor

Problem	Possible Cause	Confirmation	Correction	Reference
	Noise interference occurred because of incorrect I/O Signal Cable specifications.	Turn OFF the power supply to the servo system. Check the I/O signal cables to see if they satisfy specifications. Use shielded twisted-pair wire cables or screened twisted-pair cables with conductors of at least 0.12 mm ² .	Use cables that satisfy the specifications.	–
	Noise interference occurred because an I/O Signal Cable is too long.	Turn OFF the power supply to the servo system. Check the lengths of the I/O signal cables.	The I/O signal cables must be no longer than 3 m.	–
	Noise interference occurred because of incorrect Encoder Cable specifications.	Turn OFF the power supply to the servo system. Make sure that the rotary or Linear Encoder Cable satisfies the specifications. Use a shielded twisted-pair wire cable or a screened twisted-pair cable with a conductors of at least 0.12 mm ² .	Use cables that satisfy the specifications.	–
	Noise interference occurred because the Encoder Cable is too long.	Turn OFF the power supply to the servo system. Check the length of the Encoder Cable.	<ul style="list-style-type: none"> ■ Rotary Servomotors: The Encoder Cable length must be 50 m max. ■ Linear Servomotors: Make sure that the Serial Converter Unit cable is no longer than 20 m and that the Linear Encoder Cable and the Sensor Cable are no longer than 15 m each. 	–
	Noise interference occurred because the Encoder Cable is damaged.	Turn OFF the power supply to the servo system. Check the Encoder Cable to see if it is pinched or the sheath is damaged.	Replace the Encoder Cable and correct the cable installation environment.	–
	The Encoder Cable was subjected to excessive noise interference.	Turn OFF the power supply to the servo system. Check to see if the Encoder Cable is bundled with a high-current line or installed near a high-current line.	Correct the cable layout so that no surge is applied by high-current lines.	–

Troubleshooting Based on the Operation and Conditions of the Servomotor

Problem	Possible Cause	Confirmation	Correction	Reference
	There is variation in the FG potential because of the influence of machines on the Servomotor side, such as a welder.	Turn OFF the power supply to the servo system. Check to see if the machines are correctly grounded.	Properly ground the machines to separate them from the FG of the encoder.	–
	There is a SERVO-PACK pulse counting error due to noise.	Check to see if there is noise interference on the signal line from the encoder.	Turn OFF the power supply to the servo system. Implement countermeasures against noise for the encoder wiring.	–
	The encoder was subjected to excessive vibration or shock.	Turn OFF the power supply to the servo system. Check to see if vibration from the machine occurred. Check the Servomotor installation (mounting surface precision, securing state, and alignment). Check the linear encoder installation (mounting surface precision and securing method).	Reduce machine vibration. Improve the mounting state of the Servomotor or linear encoder.	–
	A failure occurred in the encoder.	–	Turn OFF the power supply to the servo system. Replace the Servomotor.	–
	A failure occurred in the Serial Converter Unit.	–	Turn OFF the power supply to the servo system. Replace the Serial Converter Unit.	–
	A failure occurred in the linear encoder.	–	Turn OFF the power supply to the servo system. Replace the linear encoder.	–
Servomotor Vibrates at Frequency of Approx. 200 to 400 Hz.	The servo gains are not balanced.	Check to see if the servo gains have been correctly tuned.	Perform autotuning without a host reference.	→ Chap. 9.7.1 'Autotuning without Host Reference' ...page 306
	The setting of Pn100 (Speed Loop Gain) is too high.	Check the setting of Pn100. The default setting is Kv = 40.0 Hz.	Set Pn100 to an appropriate value.	–
	The setting of Pn102 (Position Loop Gain) is too high.	Check the setting of Pn102. The default setting is Kp = 40.0/s.	Set Pn102 to an appropriate value.	–
	The setting of Pn101 (Speed Loop Integral Time Constant) is not appropriate.	Check the setting of Pn101. The default setting is Ti = 20.0 ms.	Set Pn101 to an appropriate value.	–

Troubleshooting Based on the Operation and Conditions of the Servomotor

Problem	Possible Cause	Confirmation	Correction	Reference
	The setting of Pn103 (Moment of Inertia Ratio or Mass Ratio) is not appropriate.	Check the setting of Pn103.	Set Pn103 to an appropriate value.	–
Large Motor Speed Overshoot on Starting and Stopping	The servo gains are not balanced.	Check to see if the servo gains have been correctly tuned.	Perform autotuning without a host reference.	→ Chap. 9.7.1 'Autotuning without Host Reference' ...page 306
	The setting of Pn100 (Speed Loop Gain) is too high.	Check the setting of Pn100. The default setting is Kv = 40.0 Hz.	Set Pn100 to an appropriate value.	–
	The setting of Pn102 (Position Loop Gain) is too high.	Check the setting of Pn102. The default setting is Kp = 40.0/s.	Set Pn102 to an appropriate value.	–
	The setting of Pn101 (Speed Loop Integral Time Constant) is not appropriate.	Check the setting of Pn101. The default setting is Ti = 20.0 ms.	Set Pn101 to an appropriate value.	–
	The setting of Pn103 (Moment of Inertia Ratio or Mass Ratio) is not appropriate.	Check the setting of Pn103.	Set Pn103 to an appropriate value.	–
	The torque reference is saturated.	Check the waveform of the torque reference.	Use the mode switch.	–
	The force limits (Pn483 and Pn484) are set to the default values.	The default values of the force limits are Pn483 = 30% and Pn484 = 30%.	Set Pn483 and Pn484 to appropriate values.	→ Chap. 7.8.2 'Internal Torque Limits' ...page 213
Absolute Encoder Position Deviation Error (The position that was saved in the host controller when the power was turned OFF is different from the position when the power was next turned ON.)	Noise interference occurred because of incorrect Encoder Cable specifications.	Turn OFF the power supply to the servo system. Check the Encoder Cable to see if it satisfies specifications. Use a shielded twisted-pair cables or a screened twisted-pair cable with conductors of at least 0.12 mm ² .	Use cables that satisfy the specifications.	–
	Noise interference occurred because the Encoder Cable is too long.	Turn OFF the power supply to the servo system. Check the length of the Encoder Cable.	<ul style="list-style-type: none"> ■ Rotary Servomotors: The Encoder Cable length must be 50 m max. ■ Linear Servomotors: Make sure that the Serial Converter Unit Cable is no longer than 20 m and that the Linear Encoder Cable and the Sensor Cable are no longer than 15 m each. 	–

Troubleshooting Based on the Operation and Conditions of the Servomotor

Problem	Possible Cause	Confirmation	Correction	Reference
	Noise interference occurred because the Encoder Cable is damaged.	Turn OFF the power supply to the servo system. Check the Encoder Cable to see if it is pinched or the sheath is damaged.	Replace the Encoder Cable and correct the cable installation environment.	–
	The Encoder Cable was subjected to excessive noise interference.	Turn OFF the power supply to the servo system. Check to see if the Encoder Cable is bundled with a high-current line or installed near a high-current line.	Correct the cable layout so that no surge is applied by high-current lines.	–
	There is variation in the FG potential because of the influence of machines on the Servomotor side, such as a welder.	Turn OFF the power supply to the servo system. Check to see if the machines are correctly grounded.	Properly ground the machines to separate them from the FG of the encoder.	–
	There is a SERVO-PACK pulse counting error due to noise.	Turn OFF the power supply to the servo system. Check to see if there is noise interference on the I/O signal line from the encoder or Serial Converter Unit.	Implement countermeasures against noise for the encoder or Serial Converter Unit wiring.	–
	The encoder was subjected to excessive vibration or shock.	Turn OFF the power supply to the servo system. Check to see if vibration from the machine occurred. Check the Servomotor installation (mounting surface precision, securing state, and alignment). Check the linear encoder installation (mounting surface precision and securing method).	Reduce machine vibration. Improve the mounting state of the Servomotor or linear encoder.	–
	A failure occurred in the encoder.	–	Turn OFF the power supply to the servo system. Replace the Servomotor or linear encoder.	–
	A failure occurred in the SERVOPACK.	–	Turn OFF the power supply to the servo system. Replace the SERVOPACK.	–
	Host Controller Multi-turn Data or Absolute Encoder Position Data Reading Error	Check the error detection section of the host controller.	Correct the error detection section of the host controller.	–

Troubleshooting Based on the Operation and Conditions of the Servomotor

Problem	Possible Cause	Confirmation	Correction	Reference
		Check to see if the host controller is executing data parity checks.	Perform parity checks for the multiturn data or absolute encoder position data.	–
		Check for noise interference in the cable between the SERVO-PACK and the host controller.	Implement countermeasures against noise and then perform parity checks again for the multiturn data or absolute encoder position data.	–
Overtravel Occurred	The P-OT/N-OT (Forward Drive Prohibit or Reverse Drive Prohibit) signal was input.	Check the external power supply (+24 V) voltage for the input signals.	Correct the external power supply (+24 V) voltage for the input signals.	–
		Check the operating condition of the overtravel limit switches.	Make sure that the overtravel limit switches operate correctly.	–
		Check the wiring of the overtravel limit switches.	Correct the wiring of the overtravel limit switches.	→ Chap. 6.11.1 'Overtravel and Related Settings' ...page 155
		Check the settings of the overtravel input signal allocations (Pn50A/ Pn50B).	Set the parameters to correct values.	→ Chap. 6.11.1 'Overtravel and Related Settings' ...page 155
	The P-OT/N-OT (Forward Drive Prohibit or Reverse Drive Prohibit) signal malfunctioned.	Check for fluctuation in the external power supply (+24 V) voltage for the input signals.	Eliminate fluctuation from the external power supply (+24 V) voltage for the input signals.	–
		Check to see if the operation of the overtravel limit switches is unstable.	Stabilize the operating condition of the overtravel limit switches.	–
		Check the wiring of the overtravel limit switches (e.g., check for cable damage and loose screws).	Correct the wiring of the overtravel limit switches.	–
	There is a mistake in the allocation of the P-OT or N-OT (Forward Drive Prohibit or Reverse Drive Prohibit) signal in Pn50A = n.X□□□ or Pn50B = n.□□□X.	Check to see if the P-OT signal is allocated in Pn50A = n.X□□□.	If another signal is allocated in Pn50A = n.X□□□, allocate the P-OT signal instead.	→ Chap. 6.11.1 'Overtravel and Related Settings' ...page 155
		Check to see if the N-OT signal is allocated in Pn50B = n.□□□X.	If another signal is allocated in Pn50B = n.□□□X, allocate the N-OT signal instead.	
	The selection of the Servomotor stopping method is not correct.	Check the servo OFF stopping method set in Pn001 = n.□□□X or Pn001 = n.□□X□.	Select a Servomotor stopping method other than coasting to a stop.	→ Chap. 6.11.4 'Motor Stopping Method for Overtravel' ...page 157

Troubleshooting Based on the Operation and Conditions of the Servomotor

Problem	Possible Cause	Confirmation	Correction	Reference
		Check the torque control stopping method set in Pn001 = n.□□□X or Pn001 = n.□□X□.	Select a Servomotor stopping method other than coasting to a stop.	
Improper Stop Position for Overtravel (OT) Signal	The limit switch position and dog length are not appropriate.	–	Install the limit switch at the appropriate position.	–
	The overtravel limit switch position is too close for the coasting distance.	–	Install the overtravel limit switch at the appropriate position.	–
Position Deviation (without Alarm)	Noise interference occurred because of incorrect Encoder Cable specifications.	Turn OFF the power supply to the servo system. Check the Encoder Cable to see if it satisfies specifications. Use a shielded twisted-pair wire cable or a screened twisted-pair cable with conductors of at least 0.12 mm ² .	Use cables that satisfy the specifications.	–
	Noise interference occurred because the Encoder Cable is too long.	Turn OFF the power supply to the servo system. Check the length of the Encoder Cable.	<ul style="list-style-type: none"> ■ Rotary Servomotors: The Encoder Cable length must be 50 m max. ■ Linear Servomotors: Make sure that the Serial Converter Unit Cable is no longer than 20 m and that the Linear Encoder Cable and the Sensor Cable are no longer than 15 m each. 	–
	Noise interference occurred because the Encoder Cable is damaged.	Turn OFF the power supply to the servo system. Check the Encoder Cable to see if it is pinched or the sheath is damaged.	Replace the Encoder Cable and correct the cable installation environment.	–
	The Encoder Cable was subjected to excessive noise interference.	Turn OFF the power supply to the servo system. Check to see if the Encoder Cable is bundled with a high-current line or installed near a high-current line.	Correct the cable layout so that no surge is applied by high-current lines.	–

Troubleshooting Based on the Operation and Conditions of the Servomotor

Problem	Possible Cause	Confirmation	Correction	Reference
	There is variation in the FG potential because of the influence of machines on the Servomotor side, such as a welder.	Turn OFF the power supply to the servo system. Check to see if the machines are correctly grounded.	Properly ground the machines to separate them from the FG of the encoder.	–
	There is a SERVO-PACK pulse counting error due to noise.	Turn OFF the power supply to the servo system. Check to see if there is noise interference on the I/O signal line from the encoder or Serial Converter Unit.	Implement countermeasures against noise for the encoder wiring or Serial Converter Unit wiring.	–
	The encoder was subjected to excessive vibration or shock.	Turn OFF the power supply to the servo system. Check to see if vibration from the machine occurred. Check the Servomotor installation (mounting surface precision, securing state, and alignment). Check the linear encoder installation (mounting surface precision and securing method).	Reduce machine vibration. Improve the mounting state of the Servomotor or linear encoder.	–
	The coupling between the machine and Servomotor is not suitable.	Turn OFF the power supply to the servo system. Check to see if position offset occurs at the coupling between machine and Servomotor.	Correctly secure the coupling between the machine and Servomotor.	–
	Noise interference occurred because of incorrect I/O signal cable specifications.	Turn OFF the power supply to the servo system. Check the I/O Signal Cables to see if they satisfy specifications. Use a shielded twisted-pair cables or a screened twisted-pair cable with conductors of at least 0.12 mm ² .	Use cables that satisfy the specifications.	–
	Noise interference occurred because an I/O Signal Cable is too long.	Turn OFF the power supply to the servo system. Check the lengths of the I/O Signal Cables.	The I/O Signal Cables must be no longer than 3 m.	–
	An encoder fault occurred. (The pulse count does not change.)	–	Turn OFF the power supply to the servo system. Replace the Servomotor or linear encoder.	–

Troubleshooting Based on the Operation and Conditions of the Servomotor

Problem	Possible Cause	Confirmation	Correction	Reference
	A failure occurred in the SERVOPACK.	–	Turn OFF the power supply to the servo system. Replace the SERVOPACK.	–
Servomotor Overheated	The surrounding air temperature is too high.	Measure the surrounding air temperature around the Servomotor.	Reduce the surrounding air temperature to 40°C or less.	–
	The surface of the Servomotor is dirty.	Turn OFF the power supply to the servo system. Visually check the surface for dirt.	Clean dirt, dust, and oil from the surface.	–
	There is an overload on the Servomotor.	Check the load status with a monitor.	If the Servomotor is overloaded, reduce the load or replace the Servo Drive with a SERVOPACK and Servomotor with larger capacities.	–
	Polarity detection was not performed correctly.	Check to see if electrical angle 2 (electrical angle from polarity origin) at any position is between $\pm 10^\circ$.	Correct the settings for the polarity detection-related parameters.	–

17 Parameter and Object Lists

17.1 Overview

This chapter provides information on parameters and objects.

17.2 List of Parameters

17.2.1 Interpreting the Parameter Lists

Parameter No.	Size	Name	Setting Range	Setting Unit	Default Setting	Applicable Motors *1	When Enabled *2	Classification *3	Reference
Pn000	2	Basic Function Selections 0	0000h to 10B1h	–	0000h	All	After restart	Setup	–



***1 (Applicable Motors)**

The types of Servomotors to which the parameter applies.

- All: The parameter is used for both Rotary Servomotors and Linear Servomotors.
- Rotary: The parameter is used for only Rotary Servomotors.
- Linear: The parameter is used for only Linear Servomotors.

Rotary Servomotor terms are used for parameters that are applicable to all Servomotors. If you are using a Linear Servomotor, you need to interpret the terms accordingly. Refer to the following section for details.

↪ [Chap. 1.4 'Using This Manual' ...page 23](#)

***2 (When Enabled)**

Indicates when a change to the parameter will be effective.

***3 (Classification)**

There are the following two classifications.

- Setup
- Tuning

Refer to the following section for details.

↪ [Chap. 6.2.2 'Classifications of SERVOPACK Parameters' ...page 127](#)

n.□□□X	Rotation Direction Selection		Reference
	Movement Direction Selection		
0		Use CCW as the forward direction.	↪ Chap. 6.5 'Motor Direction Setting' ...page 141
		Use the direction in which the linear encoder counts up as the forward direction.	
1		Use CW as the forward direction. (Reverse Rotation Mode)	
		Use the direction in which the linear encoder counts down as the forward direction. (Reverse Movement Mode)	



If there are differences in the parameters for Rotary Servomotor and Linear Servomotor, information is provided for both.

- Top row: For Rotary Servomotors
- Bottom row: For Linear Servomotors

n.X□□□	Rotary/Linear Servomotor Startup Selection When Encoder Is Not Connected		Reference
0	When an encoder is not connected, start as SERVOPACK for Rotary Servomotor.	↪ Chap. 6.4 'Automatic Detection of Connected Motor' ...page 140	
1	When an encoder is not connected, start as SERVOPACK for Linear Servomotor.		

17.2.2 List of Parameters

The following table lists the parameters.



Do not change the following parameters from their default settings.

- Reserved parameters
- Parameters not given in this manual
- Parameters that are not valid for the Servomotor that you are using, as given in the parameter table

Parameter No.	Size	Name	Setting Range	Setting Unit	Default Setting	Applicable Motors	When Enabled	Classification	Reference
Pn000	2	Basic Function Selections 0	0000h to 10B1h	–	0000h	All	After restart	Setup	–

n.□□□X	Rotation Direction Selection		Reference
	Movement Direction Selection		
0	Use CCW as the forward direction.	↪ Chap. 6.5 'Motor Direction Setting' ...page 141	
	Use the direction in which the linear encoder counts up as the forward direction.		
1	Use CW as the forward direction. (Reverse Rotation Mode)		
	Use the direction in which the linear encoder counts down as the forward direction. (Reverse Movement Mode)		

n.X□□□	Rotary/Linear Servomotor Startup Selection When Encoder Is Not Connected		Reference
0	When an encoder is not connected, start as SERVOPACK for Rotary Servomotor.	↪ Chap. 6.4 'Automatic Detection of Connected Motor' ...page 140	
1	When an encoder is not connected, start as SERVOPACK for Linear Servomotor.		

List of Parameters > List of Parameters

Parameter No.	Size	Name	Setting Range	Setting Unit	Default Setting	Applicable Motors	When Enabled	Classification	Reference
Pn001	2	Application Function Selections 1	0010h to 0112h	–	0010h	All	After restart	Setup	–

n.□□□X	Motor Stopping Method for Servo OFF and Group 1 Alarms	Reference
0	Stop the motor by applying the dynamic brake.	↪ Chap. 6.13.1 'Motor Stopping Methods for Servo OFF and Alarms' ...page 166
1	Stop the motor by applying the dynamic brake and then release the dynamic brake.	
2	Coast the motor to a stop without the dynamic brake.	

n.□□X□	Overtravel Stopping Method*4	Reference
1	Decelerate the motor to a stop using the torque set in Pn406 as the maximum torque and then servo-lock the motor. (Automatically set by the PROFINET Module.)	↪ Chap. 6.11.4 'Motor Stopping Method for Overtravel' ...page 157

n.□X□□	Main Circuit Power Supply AC/DC Input Selection	Reference
0	Input AC power as the main circuit power supply using the L1, L2, and L3 terminals (do not use shared converter).	↪ Chap. 6.3.1 'Power Supply Type Settings for the Main Circuit and Control Circuit' ...page 138
1	Input DC power as the main circuit power supply using the B1(⊕) and ⊖2 terminals or the B1 and ⊖2 terminals (use an external converter or the shared converter).	

Parameter No.	Size	Name	Setting Range	Setting Unit	Default Setting	Applicable Motors	When Enabled	Classification	Reference
Pn002	2	Application Function Selections 2	0001h to 4201h	–	0001h	–	After restart	Setup	–

n.□□□X	PROFINET Module Torque Limit Command Usage Selection*4	Applicable Motors	Reference
1	Enable torque limit commands from PROFINET. (Automatically set by the PROFINET Module.)		

n.□□X□	PROFINET Module Speed Limit Command Usage Selection*4	Applicable Motors	Reference
0	Disable speed limit commands from PROFINET during torque control. (Automatically set by the PROFINET Module.)	All	-

n.□X□□	Encoder Usage		Applicable Motors	Reference
	0	Use the encoder according to encoder specifications.	All	↪ Chap. 7.9.1 'Absolute Encoders' ...page 218
	1	Use the encoder as an incremental encoder.		
	2	Use the encoder as a single-turn absolute encoder.	Rotary	
n.X□□□	External Encoder Usage		Applicable Motors	Reference
	0	Do not use an external encoder.	Rotary	↪ Chap. 11.4.3 'Setting the Motor Direction and the Machine Movement Direction' ...page 433
	1	The external encoder moves in the forward direction for CCW motor rotation.		
	2	Reserved setting (Do not use.)		
	3	The external encoder moves in the reverse direction for CCW motor rotation.		
	4	Reserved setting (Do not use.)		

Parameter No.	Size	Name	Setting Range	Setting Unit	Default Setting	Applicable Motors	When Enabled	Classification	Reference
Pn006	2	Application Function Selections 6	0000h to 105Fh	–	0002h	All	Immediately	Setup	↪ Chap. 10.4.4 'Using the Analog Monitors' ...page 418

n.□□XX	Analog Monitor 1 Signal Selection	
	00	Motor speed (1 V/1,000 min ⁻¹)
		Motor speed (1 V/1,000 mm/s)
	01	Speed reference (1 V/1,000 min ⁻¹)
		Speed reference (1 V/1,000 mm/s)
	02	Torque reference (1 V/100% rated torque)
		Force reference (1 V/100% rated force)
	03	Position deviation (0.05 V/reference unit)
	04	Position amplifier deviation (after electronic gear) (0.05 V/encoder pulse unit)
		Position amplifier deviation (after electronic gear) (0.05 V/linear encoder pulse unit)
	05	Position reference speed (1 V/1,000 min ⁻¹)
		Position reference speed (1 V/1,000 mm/s)
	06	Reserved setting (Do not use.)

n.□□XX	Analog Monitor 1 Signal Selection	
07	Load-motor position deviation (0.01 V/reference unit)	
08	Positioning completion (positioning completed: 5 V, positioning not completed: 0 V)	
09	Speed feedforward (1 V/1,000 min ⁻¹)	
	Speed feedforward (1 V/1,000 mm/s)	
0A	Torque feedforward (1 V/100% rated torque)	
	Force feedforward (1 V/100% rated force)	
0B	Active gain (1st gain: 1 V, 2nd gain: 2 V)	
0C	Completion of position reference distribution (completed: 5 V, not completed: 0 V)	
0D	External encoder speed (1 V/1,000 min ⁻¹ : value at the motor shaft)	
0E	Reserved setting (Do not use.)	
0F	Reserved setting (Do not use.)	
10	Main circuit DC voltage	
11 to 15F	Reserved settings (Do not use.)	

Parameter No.	Size	Name	Setting Range	Setting Unit	Default Setting	Applicable Motors	When Enabled	Classification	Reference
Pn007	2	Application Function Selections 7	0000h to 105Fh	–	0000h	All	Immediately	Setup	→ Chap. 10.4.4 'Using the Analog Monitors' ...page 418

n.□□XX	Analog Monitor 2 Signal Selection	
00	Motor speed (1 V/1,000 min ⁻¹)	
	Motor speed (1 V/1,000 mm/s)	
01	Speed reference (1 V/1,000 min ⁻¹)	
	Speed reference (1 V/1,000 mm/s)	
02	Torque reference (1 V/100% rated torque)	
	Force reference (1 V/100% rated force)	
03	Position deviation (0.05 V/reference unit)	
04	Position amplifier deviation (after electronic gear) (0.05 V/encoder pulse unit)	
	Position amplifier deviation (after electronic gear) (0.05 V/linear encoder pulse unit)	
05	Position reference speed (1 V/1,000 min ⁻¹)	
	Position reference speed (1 V/1,000 mm/s)	
06	Reserved setting (Do not use.)	

n.□□XX	Analog Monitor 2 Signal Selection	
07	Load-motor position deviation (0.01 V/reference unit)	
08	Positioning completion (positioning completed: 5 V, positioning not completed: 0 V)	
09	Speed feedforward (1 V/1,000 min ⁻¹)	
	Speed feedforward (1 V/1,000 mm/s)	
0A	Torque feedforward (1 V/100% rated torque)	
	Force feedforward (1 V/100% rated force)	
0B	Active gain (1st gain: 1 V, 2nd gain: 2 V)	
0C	Completion of position reference distribution (completed: 5 V, not completed: 0 V)	
0D	External encoder speed (1 V/1,000 min ⁻¹ : value at the motor shaft)	
0E	Reserved setting (Do not use.)	
0F	Reserved setting (Do not use.)	
10	Main circuit DC voltage	
11 to 15F	Reserved settings (Do not use.)	

Parameter No.	Size	Name	Setting Range	Setting Unit	Default Setting	Applicable Motors	When Enabled	Classification	Reference
Pn008	2	Application Function Selections 8	0000h to 7121h	–	4000h	Rotary	After restart	Setup	-

n.□□□X	Low Battery Voltage Alarm/Warning Selection		Reference
0	Output alarm (A.830) for low battery voltage.		↪ Chap. 16.2.4 'Replacing the Battery' ...page 547
1	Output warning (A.930) for low battery voltage.		

n.□□□□	Function Selection for Undervoltage		Reference
0	Do not detect undervoltage.		↪ Chap. 7.4 'SEMI F47 Function' ...page 201
1	Detect undervoltage warning and limit torque at host controller.		
2	Detect undervoltage warning and limit torque with Pn424 and Pn425 (i.e., only in the SERVOPACK).		

n.□X□□	Warning Detection Selection		Reference
0	Detect warnings.		↪ Chap. 16.5.1 'Warning Displays' ...page 600
1	Do not detect warnings except for A.971.		

List of Parameters > List of Parameters

Parameter No.	Size	Name	Setting Range	Setting Unit	Default Setting	Applicable Motors	When Enabled	Classification	Reference
Pn009	2	Application Function Selections 9	0000h to 0121h	–	0010h	All	After restart	Tuning	-

n.□□□□	Current Control Mode Selection		Reference
	0	Use current control mode 1.	↪ Chap. 9.13.5 'Current Control Mode Selection' ...page 377
	1	<ul style="list-style-type: none"> ■ SERVOPACK Models SGD7S-R70A, -R90A, -1R6A, -2R8A, -3R8A, -5R5A, and -7R6A: Use current control mode 1. ■ SERVOPACK Models SGD7S-120A, -180A, -200A, -330A, -470A, -550A, -590A, and -780A: Use current control mode 2. 	
	2	Use current control mode 2.	

n.□X□□	Speed Detection Method Selection		Reference
	0	Use speed detection 1.	↪ Chap. 9.13.7 'Speed Detection Method Selection' ...page 378
	1	Use speed detection 2.	

Parameter No.	Size	Name	Setting Range	Setting Unit	Default Setting	Applicable Motors	When Enabled	Classification	Reference
Pn00A	2	Application Function Selections A	0000h to 1044h	–	0001h	All	After restart	Setup	-

n.□□□X	Motor Stopping Method for Group 2 Alarms		Reference
	0	Apply the dynamic brake or coast the motor to a stop (use the stopping method set in Pn001 = n.□□□X).	↪ Chap. 6.13.2 'Stopping Method for Servo OFF' ...page 168
	1	Decelerate the motor to a stop using the torque set in Pn406 as the maximum torque. Use the setting of Pn001 = n.□□□X for the status after stopping.	
	2	Decelerate the motor to a stop using the torque set in Pn406 as the maximum torque and then let the motor coast.	
	3	Decelerate the motor to a stop using the deceleration time set in Pn30A. Use the setting of Pn001 = n.□□□X for the status after stopping.	
	4	Decelerate the motor to a stop using the deceleration time set in Pn30A and then let the motor coast.	

n.□□□□	Stopping Method for Forced Stops		Reference
	0	Apply the dynamic brake or coast the motor to a stop (use the stopping method set in Pn001 = n.□□□X).	↪ Chap. 7.14.3 'Stopping Method Selection'

n.□□X□	Stopping Method for Forced Stops		Reference
	1	Decelerate the motor to a stop using the torque set in Pn406 as the maximum torque. Use the setting of Pn001 = n.□□□X for the status after stopping.	<i>tion for Forced Stops' ...page 246</i>
	2	Decelerate the motor to a stop using the torque set in Pn406 as the maximum torque and then let the motor coast.	
	3	Decelerate the motor to a stop using the deceleration time set in Pn30A. Use the setting of Pn001 = n.□□□X for the status after stopping.	
	4	Decelerate the motor to a stop using the deceleration time set in Pn30A and then let the motor coast.	

Parameter No.	Size	Name	Setting Range	Setting Unit	Default Setting	Applicable Motors	When Enabled	Classification	Reference
Pn00B	2	Application Function Selections B	0000h to 1121h	–	0000h	All	After restart	Setup	-

n.□□□X	Operator Parameter Display Selection		Reference
	0	Display only setup parameters.	<i>↪ Chap. 6.2.2 'Classifications of SERVO-PACK Parameters' ...page 127</i>
	1	Display all parameters.	

n.□□X□	Motor Stopping Method for Group 2 Alarms		Reference
	0	Stop the motor by setting the speed reference to 0.	<i>↪ Chap. 6.13.2 'Stopping Method for Servo OFF' ...page 168</i>
	1	Apply the dynamic brake or coast the motor to a stop (use the stopping method set in Pn001 = n.□□□X).	
	2	Set the stopping method with Pn00A = n.□□□X.	

n.□X□□	Power Input Selection for Three-phase SERVOPACK		Reference
	0	Use a three-phase power supply input.	<i>↪ Chap. 6.3.3 'Single-phase AC Power Supply Input/ Three-phase AC Power Supply Input Setting' ...page 139</i>
	1	Use a three-phase power supply input and as a single-phase power supply input.	

List of Parameters > List of Parameters

Parameter No.	Size	Name	Setting Range	Setting Unit	Default Setting	Applicable Motors	When Enabled	Classification	Reference
Pn00C	2	Application Function Selections C	0000h to 0131h	–	0000h	–	After restart	Setup	→ Chap. 8.7.4 'Test without a Motor' ...page 275

n.□□□X	Function Selection for Test without a Motor		Applicable Motors
0	Disable tests without a motor.		All
1	Enable tests without a motor.		

n.□□□□	Encoder Resolution for Tests without a Motor		Applicable Motors
0	Use 13 bits.		Rotary
1	Use 20 bits.		
2	Use 22 bits.		
3	Use 24 bits.		

n.□X□□	Encoder Type Selection for Tests without a Motor		Applicable Motors
0	Use an incremental encoder.		All
1	Use an absolute encoder.		

Parameter No.	Size	Name	Setting Range	Setting Unit	Default Setting	Applicable Motors	When Enabled	Classification	Reference
Pn00D	2	Application Function Selections D	0000h to 1001h	–	0000h	All	After restart	Setup	→ Chap. 6.11.5 'Overtravel Warnings' ...page 158

n.X□□□	Overtravel Warning Detection Selection	
0	Do not detect overtravel warnings.	
1	Detect overtravel warnings.	

Parameter No.	Size	Name	Setting Range	Setting Unit	Default Setting	Applicable Motors	When Enabled	Classification	Reference
Pn00F	2	Application Function Selections F	0000h to 2011h	–	0000h	All	After restart	Setup	–

n.□□□X	Preventative Maintenance Warning Selection		Reference
	0	Do not detect preventative maintenance warnings.	↪ Chap. 10.5.3 'Preventative Maintenance' ...page 426
	1	Detect preventative maintenance warnings.	

Parameter No.	Size	Name	Setting Range	Setting Unit	Default Setting	Applicable Motors	When Enabled	Classification	Reference
Pn021	2	Reserved parameter (Do not change.)	–	–	0000h	All	–	–	–

Parameter No.	Size	Name	Setting Range	Setting Unit	Default Setting	Applicable Motors	When Enabled	Classification	Reference
Pn022	2	Application Function Selections 22	0000h to 0011h	–	0000h	All	After restart	Setup	–

n.□□□X	Overtravel Release Method Selection		Reference
	0	Overtravel exists while the P-OT or N-OT signal is being input.	↪ Chap. 6.11.6 'Overtravel Release Method Selection' ...page 160
	1	Overtravel exists while the P-OT or N-OT signal is input and the current position of the workpiece is separated from the P-OT signal or N-OT signal.	

Parameter No.	Size	Name	Setting Range	Setting Unit	Default Setting	Applicable Motors	When Enabled	Classification	Reference
Pn040	2	Reserved parameter (Do not change.)	0000h to 2111h	–	0000h	–	–	–	–

Parameter No.	Size	Name	Setting Range	Setting Unit	Default Setting	Applicable Motors	When Enabled	Classification	Reference
Pn080	2	Application Function Selections 80	0000h to 1111h	–	0000h	Linear	After restart	Setup	–

n.□□□X	Polarity Sensor Selection		Reference
	0	Use polarity sensor.	↪ Chap. 6.9 'Polarity Sensor Setting' ...page 152
	1	Do not use polarity sensor.	

List of Parameters > List of Parameters

n.□□X□	Motor Phase Sequence Selection		Reference
0	Set a phase-A lead as a phase sequence of U, V, and W.		↪ Chap. 6.8 'Selecting the Phase Sequence for a Linear Servomotor' ...page 150
1	Set a phase-B lead as a phase sequence of U, V, and W.		

n.X□□□	Calculation Method for Maximum Speed or Encoder Output Pulses		Reference
0	Calculate the encoder output pulse setting for a fixed maximum speed.		↪ Chap. 18.3.3 'Corresponding SERVOPACK Monitor Display Function Names' ...page 710
1	Calculate the maximum speed for a fixed encoder output pulse setting.		

Parameter No.	Size	Name	Setting Range	Setting Unit	Default Setting	Applicable Motors	When Enabled	Classification	Reference
Pn081	2	Application Function Selections 81	0000h to 1111h	–	0000h	All	After restart	Setup	↪ Chap. 7.6.1 'Encoder Divided Pulse Output' ...page 204

n.□□□X	Phase-C Pulse Output Selection	
0	Output phase-C pulses only in the forward direction.	
1	Output phase-C pulses in both the forward and reverse directions.	

Parameter No.	Size	Name	Setting Range	Setting Unit	Default Setting	Applicable Motors	When Enabled	Classification	Reference
Pn100	2	Speed Loop Gain	10 to 20,000	0.1 Hz	400	All	Immediately	Tuning	↪ Chap. 9.14.1 'Manual Tuning' ...page 384

Parameter No.	Size	Name	Setting Range	Setting Unit	Default Setting	Applicable Motors	When Enabled	Classification	Reference
Pn101	2	Speed Loop Integral Time Constant	15 to 51,200	0.01 ms	2000	All	Immediately	Tuning	↪ Chap. 9.14.1 'Manual Tuning' ...page 384

Parameter No.	Size	Name	Setting Range	Setting Unit	Default Setting	Applicable Motors	When Enabled	Classification	Reference
Pn102	2	Position Loop Gain	10 to 20,000	0.1/s	400	All	Immediately	Tuning	↪ Chap. 9.14.1 'Manual Tuning' ...page 384

Parameter No.	Size	Name	Setting Range	Setting Unit	Default Setting	Applicable Motors	When Enabled	Classification	Reference
Pn103	2	Moment of Inertia Ratio	0 to 20,000	1%	100	All	Immediately	Tuning	↪ Chap. 9.14.1 'Manual Tuning' ...page 384

Parameter No.	Size	Name	Setting Range	Setting Unit	Default Setting	Applicable Motors	When Enabled	Classification	Reference
Pn104	2	Second Speed Loop Gain	10 to 20,000	0.1 Hz	400	All	Immediately	Tuning	↪ Chap. 9.13.2 'Gain Switching' ...page 370

Parameter No.	Size	Name	Setting Range	Setting Unit	Default Setting	Applicable Motors	When Enabled	Classification	Reference
Pn105	2	Second Speed Loop Integral Time Constant	15 to 51,200	0.01 ms	2000	All	Immediately	Tuning	↪ Chap. 9.13.2 'Gain Switching' ...page 370

Parameter No.	Size	Name	Setting Range	Setting Unit	Default Setting	Applicable Motors	When Enabled	Classification	Reference
Pn106	2	Second Position Loop Gain	10 to 20,000	0.1/s	400	All	Immediately	Tuning	↪ Chap. 9.13.2 'Gain Switching' ...page 370

List of Parameters > List of Parameters

Parameter No.	Size	Name	Setting Range	Setting Unit	Default Setting	Applicable Motors	When Enabled	Classification	Reference
Pn109	2	Feedforward	0 to 100	1%	0	All	Immediately	Tuning	↪ Chap. 9.14.3 'Compatible Adjustment Functions' ...page 397

Parameter No.	Size	Name	Setting Range	Setting Unit	Default Setting	Applicable Motors	When Enabled	Classification	Reference
Pn10A	2	Feedforward Filter Time Constant	0 to 6,400	0.01 ms	0	All	Immediately	Tuning	↪ Chap. 9.14.3 'Compatible Adjustment Functions' ...page 397

Parameter No.	Size	Name	Setting Range	Setting Unit	Default Setting	Applicable Motors	When Enabled	Classification	Reference
Pn10B	2	Gain Application Selections	0000h to 5334h	–	0000h	All	–	Tuning	–

n.□□□X	Mode Switching Selection		When Enabled	Reference
	0	Use the internal torque reference as the condition (level setting: Pn10C).	Immediately	↪ Chap. 9.14.3 'Compatible Adjustment Functions' ...page 397
	1	Use the speed reference as the condition (level setting: Pn10D).		
		Use the speed reference as the condition (level setting: Pn181).		
	2	Use the acceleration reference as the condition (level setting: Pn10E).		
		Use the acceleration reference as the condition (level setting: Pn182).		
	3	Use the position deviation as the condition (level setting: Pn10F).		
4	Do not use mode switching.			
n.□□X□	Speed Loop Control Method		When Enabled	Reference
	0	PI control	After Restart	↪ Chap. 9.14.1 'Manual Tuning' ...page 384
	1	I-P control		

n.□□X□	Speed Loop Control Method	When Enabled	Reference
2 and 3	Reserved settings (Do not use.)		

Parameter No.	Size	Name	Setting Range	Setting Unit	Default Setting	Applicable Motors	When Enabled	Classification	Reference
Pn10C	2	Mode Switching Level for Torque Reference	0 to 800	1%	200	All	Immediately	Tuning	↪ Chap. 9.14.3 'Compatible Adjustment Functions' ...page 397

Parameter No.	Size	Name	Setting Range	Setting Unit	Default Setting	Applicable Motors	When Enabled	Classification	Reference
Pn10D	2	Mode Switching Level for Speed Reference	0 to 10,000	1 min ⁻¹	0	Rotary	Immediately	Tuning	↪ Chap. 9.14.3 'Compatible Adjustment Functions' ...page 397

Parameter No.	Size	Name	Setting Range	Setting Unit	Default Setting	Applicable Motors	When Enabled	Classification	Reference
Pn10E	2	Mode Switching Level for Acceleration	0 to 30,000	1 min ⁻¹ /s	0	Rotary	Immediately	Tuning	↪ Chap. 9.14.3 'Compatible Adjustment Functions' ...page 397

List of Parameters > List of Parameters

Parameter No.	Size	Name	Setting Range	Setting Unit	Default Setting	Applicable Motors	When Enabled	Classification	Reference
Pn10F	2	Mode Switching Level for Position Deviation	0 to 10,000	1 reference unit	0	All	Immediately	Tuning	↪ Chap. 9.14.3 'Compatible Adjustment Functions' ...page 397

Parameter No.	Size	Name	Setting Range	Setting Unit	Default Setting	Applicable Motors	When Enabled	Classification	Reference
Pn11F	2	Position Integral Time Constant	0 to 50,000	0.1 ms	0	All	Immediately	Tuning	↪ Chap. 9.14.3 'Compatible Adjustment Functions' ...page 397

Parameter No.	Size	Name	Setting Range	Setting Unit	Default Setting	Applicable Motors	When Enabled	Classification	Reference
Pn121	2	Friction Compensation Gain	10 to 1,000	1%	100	All	Immediately	Tuning	↪ Chap. 9.13.2 'Gain Switching' ...page 370, ↪ Chap. 9.13.3 'Friction Compensation' ...page 374

Parameter No.	Size	Name	Setting Range	Setting Unit	Default Setting	Applicable Motors	When Enabled	Classification	Reference
Pn122	2	Second Friction Compensation Gain	10 to 1,000	1%	100	All	Immediately	Tuning	↪ Chap. 9.13.2 'Gain Switching' ...page 370, ↪ Chap. 9.13.3 'Friction Compensation' ...page 374

Parameter No.	Size	Name	Setting Range	Setting Unit	Default Setting	Applicable Motors	When Enabled	Classification	Reference
Pn123	2	Friction Compensation Coefficient	0 to 100	1%	0	All	Immediately	Tuning	↪ Chap. 9.13.3 'Friction Compensation' ...page 374

Parameter No.	Size	Name	Setting Range	Setting Unit	Default Setting	Applicable Motors	When Enabled	Classification	Reference
Pn124	2	Friction Compensation Frequency Correction	-10,000 to 10,000	0.1 Hz	0	All	Immediately	Tuning	↪ Chap. 9.13.3 'Friction Compensation' ...page 374

Parameter No.	Size	Name	Setting Range	Setting Unit	Default Setting	Applicable Motors	When Enabled	Classification	Reference
Pn125	2	Friction Compensation Gain Correction	1 to 1,000	1%	100	All	Immediately	Tuning	↪ Chap. 9.13.3 'Friction Compensation' ...page 374

Parameter No.	Size	Name	Setting Range	Setting Unit	Default Setting	Applicable Motors	When Enabled	Classification	Reference
Pn131	2	Gain Switching Time 1	0 to 65,535	1 ms	0	All	Immediately	Tuning	↪ Chap. 9.13.2 'Gain Switching' ...page 370

Parameter No.	Size	Name	Setting Range	Setting Unit	Default Setting	Applicable Motors	When Enabled	Classification	Reference
Pn132	2	Gain Switching Time 2	0 to 65,535	1 ms	0	All	Immediately	Tuning	↪ Chap. 9.13.2 'Gain Switching' ...page 370

List of Parameters > List of Parameters

Parameter No.	Size	Name	Setting Range	Setting Unit	Default Setting	Applicable Motors	When Enabled	Classification	Reference
Pn135	2	Gain Switching Waiting Time 1	0 to 65,535	1 ms	0	All	Immediately	Tuning	→ Chap. 9.13.2 'Gain Switching' ...page 370

Parameter No.	Size	Name	Setting Range	Setting Unit	Default Setting	Applicable Motors	When Enabled	Classification	Reference
Pn136	2	Gain Switching Waiting Time 2	0 to 65,535	1 ms	0	All	Immediately	Tuning	→ Chap. 9.13.2 'Gain Switching' ...page 370

Parameter No.	Size	Name	Setting Range	Setting Unit	Default Setting	Applicable Motors	When Enabled	Classification	Reference
Pn139	2	Automatic Gain Switching Selections 1	0000h to 0052h	–	0000h	All	Immediately	Tuning	→ Chap. 9.13.2 'Gain Switching' ...page 370

n.□□□X	Gain Switching Selection	
	0	Disable automatic gain switching.
	1	Reserved setting (Do not use.)
	2	Use automatic gain switching pattern 1. The gain is switched automatically from the first gain to the second gain when switching condition A is satisfied. The gain is switched automatically from the second gain to the first gain when switching condition A is not satisfied.

n.□□□□	Gain Switching Condition A	
	0	/COIN (Positioning Completion Output) signal turns ON.
	1	/COIN (Positioning Completion Output) signal turns OFF.
	2	/NEAR (Near Output) signal turns ON.
	3	/NEAR (Near Output) signal turns OFF.
	4	Position reference filter output is 0 and position reference input is OFF.
	5	Position reference input is ON.

Parameter No.	Size	Name	Setting Range	Setting Unit	Default Setting	Applicable Motors	When Enabled	Classification	Reference
Pn13D	2	Current Gain Level	100 to 2,000	1%	2000	All	Immediately	Tuning	↪ Chap. 9.13.6 'Current Gain Level Setting' ...page 378

Parameter No.	Size	Name	Setting Range	Setting Unit	Default Setting	Applicable Motors	When Enabled	Classification	Reference
Pn140	2	Model Following Control- Related Selections	0000h to 1121h	–	0100h	All	Immediately	Tuning	–

n.□□□X	Model Following Control Selection		Reference
	0	Do not use model following control.	↪ Chap. 9.14.1 'Manual Tuning' ...page 384
	1	Use model following control.	

n.□□□□	Vibration Suppression Selection		Reference
	0	Do not perform vibration suppression.	↪ Chap. 9.14.1 'Manual Tuning' ...page 384
	1	Perform vibration suppression for a specific frequency.	
	2	Perform vibration suppression for two specific frequencies.	

n.□X□□	Vibration Suppression Adjustment Selection		Reference
	0	Do not adjust vibration suppression automatically during execution of autotuning without a host reference, autotuning with a host reference, and custom tuning.	↪ Chap. 9.7.6 'Troubleshooting Problems in Autotuning without a Host Reference' ...page 316
	1	Adjust vibration suppression automatically during execution of autotuning without a host reference, autotuning with a host reference, and custom tuning.	

n.X□□□	Speed Feedforward (VFF)/Torque Feedforward (TFF) Selection		Reference
	0	Do not use model following control and speed/torque feedforward together.	↪ Chap. 9.7.6 'Troubleshooting Problems in Autotuning without a Host Reference' ...page 316
	1	Use model following control and speed/torque feedforward together.	

List of Parameters > List of Parameters

Parameter No.	Size	Name	Setting Range	Setting Unit	Default Setting	Applicable Motors	When Enabled	Classification	Reference
Pn141	2	Model Following Control Gain	10 to 20,000	0.1/s	500	All	Immediately	Tuning	→ Chap. 9.14.1 'Manual Tuning' ...page 384

Parameter No.	Size	Name	Setting Range	Setting Unit	Default Setting	Applicable Motors	When Enabled	Classification	Reference
Pn142	2	Model Following Control Gain Correction	500 to 2,000	0.1%	1000	All	Immediately	Tuning	→ Chap. 9.13.2 'Gain Switching' ...page 370

Parameter No.	Size	Name	Setting Range	Setting Unit	Default Setting	Applicable Motors	When Enabled	Classification	Reference
Pn143	2	Model Following Control Bias in the Forward Direction	0 to 10,000	0.1%	1000	All	Immediately	Tuning	→ Chap. 9.14.1 'Manual Tuning' ...page 384

Parameter No.	Size	Name	Setting Range	Setting Unit	Default Setting	Applicable Motors	When Enabled	Classification	Reference
Pn144	2	Model Following Control Bias in the Reverse Direction	0 to 10,000	0.1%	1000	All	Immediately	Tuning	→ Chap. 9.14.1 'Manual Tuning' ...page 384

Parameter No.	Size	Name	Setting Range	Setting Unit	Default Setting	Applicable Motors	When Enabled	Classification	Reference
Pn145	2	Vibration Suppression 1 Frequency A	10 to 2,500	0.1 Hz	500	All	Immediately	Tuning	→ Chap. 9.11.1 'Vibration Suppression' ...page 355

Parameter No.	Size	Name	Setting Range	Setting Unit	Default Setting	Applicable Motors	When Enabled	Classification	Reference
Pn146	2	Vibration Suppression 1 Frequency B	10 to 2,500	0.1 Hz	700	All	Immediately	Tuning	→ Chap. 9.11.1 'Vibration Suppression' ...page 355

Parameter No.	Size	Name	Setting Range	Setting Unit	Default Setting	Applicable Motors	When Enabled	Classification	Reference
Pn147	2	Model Following Control Speed Feedforward Compensation	0 to 10,000	0.1%	1000	All	Immediately	Tuning	→ Chap. 9.14.1 'Manual Tuning' ...page 384

Parameter No.	Size	Name	Setting Range	Setting Unit	Default Setting	Applicable Motors	When Enabled	Classification	Reference
Pn148	2	Second Model Following Control Gain	10 to 20,000	0.1/s	500	All	Immediately	Tuning	→ Chap. 9.14.1 'Manual Tuning' ...page 384

Parameter No.	Size	Name	Setting Range	Setting Unit	Default Setting	Applicable Motors	When Enabled	Classification	Reference
Pn149	2	Second Model Following Control Gain Correction	500 to 2,000	0.1%	1000	All	Immediately	Tuning	→ Chap. 9.14.1 'Manual Tuning' ...page 384

Parameter No.	Size	Name	Setting Range	Setting Unit	Default Setting	Applicable Motors	When Enabled	Classification	Reference
Pn14A	2	Vibration Suppression 2 Frequency	10 to 2,000	0.1 Hz	800	All	Immediately	Tuning	→ Chap. 9.11.1 'Vibration Suppression' ...page 355

Parameter No.	Size	Name	Setting Range	Setting Unit	Default Setting	Applicable Motors	When Enabled	Classification	Reference
Pn14B	2	Vibration Suppression 2 Correction	10 to 1,000	1%	100	All	Immediately	Tuning	→ Chap. 9.11.1 'Vibration Suppression' ...page 355

Parameter No.	Size	Name	Setting Range	Setting Unit	Default Setting	Applicable Motors	When Enabled	Classification	Reference
Pn14F	2	Control-Related Selections	0000h to 0021h	–	0021h	All	After restart	Tuning	–

List of Parameters > List of Parameters

n.□□□X	Model Following Control Type Selection		Reference
	0	Use model following control type 1.	↪ Chap. 9.14.2 'Tuning the Servo Gains' ...page 385
	1	Use model following control type 2.	

n.□□X□	Tuning-less Type Selection		Reference
	0	Use tuning-less type 1.	↪ Chap. 9.5.3 'Operating Procedure' ...page 291
	1	Use tuning-less type 2.	
	2	Use tuning-less type 3.	

Parameter No.	Size	Name	Setting Range	Setting Unit	Default Setting	Applicable Motors	When Enabled	Classification	Reference
Pn160	2	Anti-Resonance Control- Related Selections	0000h to 0011h	–	0010h	All	Immediately	Tuning	–

n.□□□X	Anti-Resonance Control Selection		Reference
	0	Do not use anti-resonance control.	↪ Chap. 9.10.1 'Anti-Resonance Control Adjustment' ...page 347
	1	Use anti-resonance control.	

n.□□X□	Anti-Resonance Control Adjustment Selection		Reference
	0	Do not adjust anti-resonance control automatically during execution of autotuning without a host reference, autotuning with a host reference, and custom tuning.	↪ Chap. 9.7.6 'Troubleshooting Problems in Auto-tuning without a Host Reference' ...page 316
	1	Adjust anti-resonance control automatically during execution of autotuning without a host reference, autotuning with a host reference, and custom tuning.	

Parameter No.	Size	Name	Setting Range	Setting Unit	Default Setting	Applicable Motors	When Enabled	Classification	Reference
Pn161	2	Anti-Resonance Frequency	10 to 20,000	0.1 Hz	1000	All	Immediately	Tuning	↪ Chap. 9.10.1 'Anti-Resonance Control Adjustment' ...page 347

Parameter No.	Size	Name	Setting Range	Setting Unit	Default Setting	Applicable Motors	When Enabled	Classification	Reference
Pn162	2	Anti-Resonance Gain Correction	1 to 1,000	1%	100	All	Immediately	Tuning	↔ Chap. 9.10.1 'Anti-Resonance Control Adjustment' ...page 347

Parameter No.	Size	Name	Setting Range	Setting Unit	Default Setting	Applicable Motors	When Enabled	Classification	Reference
Pn163	2	Anti-Resonance Damping Gain	0 to 300	1%	0	All	Immediately	Tuning	↔ Chap. 9.10.1 'Anti-Resonance Control Adjustment' ...page 347

Parameter No.	Size	Name	Setting Range	Setting Unit	Default Setting	Applicable Motors	When Enabled	Classification	Reference
Pn164	2	Anti-Resonance Filter Time Constant 1 Correction	-1,000 to 1,000	0.01 ms	0	All	Immediately	Tuning	↔ Chap. 9.10.1 'Anti-Resonance Control Adjustment' ...page 347

Parameter No.	Size	Name	Setting Range	Setting Unit	Default Setting	Applicable Motors	When Enabled	Classification	Reference
Pn165	2	Anti-Resonance Filter Time Constant 2 Correction	-1,000 to 1,000	0.01 ms	0	All	Immediately	Tuning	↔ Chap. 9.10.1 'Anti-Resonance Control Adjustment' ...page 347

List of Parameters > List of Parameters

Parameter No.	Size	Name	Setting Range	Setting Unit	Default Setting	Applicable Motors	When Enabled	Classification	Reference
Pn166	2	Anti-Resonance Damping Gain 2	0 to 1,000	1%	0	All	Immediately	Tuning	↪ Chap. 9.10.1 'Anti-Resonance Control Adjustment' ...page 347

Parameter No.	Size	Name	Setting Range	Setting Unit	Default Setting	Applicable Motors	When Enabled	Classification	Reference
Pn170	2	Tuning-less Function-Related Selections	0000h to 2711h	–	1401h	All	–	Setup	↪ Chap. 9.5.1 'Tuning-less Function' ...page 290

n.□□□X	Tuning-less Selection		When Enabled
0	Disable tuning-less function.		After Restart
1	Enable tuning-less function.		

n.□□X□	Speed Control Method		When Enabled
0	Use for speed control.		After Restart
1	Use for speed control and use host controller for position control.		

n.□X□□	Rigidity Level		When Enabled
0 to 7	Set the rigidity level.		Immediately

n.X□□□	Tuning-less Load Level		When Enabled
0 to 2	Set the load level for the tuning-less function.		Immediately

Parameter No.	Size	Name	Setting Range	Setting Unit	Default Setting	Applicable Motors	When Enabled	Classification	Reference
Pn181	2	Mode Switching Level for Speed Reference	0 to 10,000	1 mm/s	0	Linear	Immediately	Tuning	↪ Chap. 9.14.3 'Compatible Adjustment Functions' ...page 397

Parameter No.	Size	Name	Setting Range	Setting Unit	Default Setting	Applicable Motors	When Enabled	Classification	Reference
Pn182	2	Mode Switching Level for Acceleration	0 to 30,000	1 mm/ s ²	0	Linear	Immediately	Tuning	↪ Chap. 9.14.3 'Compatible Adjustment Functions' ...page 397

Parameter No.	Size	Name	Setting Range	Setting Unit	Default Setting	Applicable Motors	When Enabled	Classification	Reference
Pn205	2	Multiturn Limit	0 to 65,535	1 rev	65535	Rotary	After restart	Setup	↪ Chap. 7.9.8 'Multiturn Limit Setting' ...page 224

Parameter No.	Size	Name	Setting Range	Setting Unit	Default Setting	Applicable Motors	When Enabled	Classification	Reference
Pn207	2	Position Control Function Selections	0000h to 2210h	–	0010h	All	After restart	Setup	–

n.X□□□	/COIN (Positioning Completion Output) Signal Output Timing	Reference
0	Output when the absolute value of the position deviation is the same or less than the setting of Pn522 (Positioning Completed Width).	↪ Chap. 7.2.9 '/COIN (Positioning Completion) Signal' ...page 196
1	Output when the absolute value of the position error is the same or less than the setting of Pn522 (Positioning Completed Width) and the reference after the position reference filter is 0.	
2	Output when the absolute value of the position error is the same or less than the setting of Pn522 (Positioning Completed Width) and the reference input is 0.	

List of Parameters > List of Parameters

Parameter No.	Size	Name	Setting Range	Setting Unit	Default Setting	Applicable Motors	When Enabled	Classification	Reference
Pn20A	4	Number of External Encoder Scale Pitches	4 to 1,048,576	1 scale pitch/ revolution	32768	Rotary	After restart	Setup	→ Chap. 11.4.4 'Setting the Number of External Encoder Scale Pitches' ...page 434

Parameter No.	Size	Name	Setting Range	Setting Unit	Default Setting	Applicable Motors	When Enabled	Classification	Reference
Pn20E	4	Electronic Gear Ratio (Numerator) ^{*4}	1 to 1,073,741,824	1	1	All	After restart	Setup	→ Chap. 6.15.1 'Setting Unit Systems' ...page 171

Parameter No.	Size	Name	Setting Range	Setting Unit	Default Setting	Applicable Motors	When Enabled	Classification	Reference
Pn210	4	Electronic Gear Ratio (Denominator) ^{*4}	1 to 1,073,741,824	1	1	All	After restart	Setup	→ Chap. 6.15.1 'Setting Unit Systems' ...page 171

Parameter No.	Size	Name	Setting Range	Setting Unit	Default Setting	Applicable Motors	When Enabled	Classification	Reference
Pn212	4	Number of Encoder Output Pulses	16 to 1,073,741,824	1 P/Rev	2048	Rotary	After restart	Setup	→ Chap. 7.6.3 'Setting for the Encoder Divided Pulse Output' ...page 210

Parameter No.	Size	Name	Setting Range	Setting Unit	Default Setting	Applicable Motors	When Enabled	Classification	Reference
Pn22A	2	Fully-closed Control Selections	0000h to 1003h	–	0000h	Rotary	After restart	Setup	↪ Chap. 11.4.10 'Setting to Use an External Encoder for Speed Feedback' ...page 437

n.X□□□	Fully-closed Control Speed Feedback Selection	
0	Use motor encoder speed.	
1	Use external encoder speed.	

Parameter No.	Size	Name	Setting Range	Setting Unit	Default Setting	Applicable Motors	When Enabled	Classification	Reference
Pn230	2	Position Control Expansion Function Selections	0000h to 0001h	–	0000h	All	After restart	Setup	↪ Chap. 9.13.9 'Backlash Compensation' ...page 379

n.□□□X	Backlash Compensation Direction	
0	Compensate forward references.	
1	Compensate reverse references.	

Parameter No.	Size	Name	Setting Range	Setting Unit	Default Setting	Applicable Motors	When Enabled	Classification	Reference
Pn231	4	Backlash Compensation	-500,000 to 500,000	0.1 reference units	0	All	Immediately	Setup	↪ Chap. 9.13.9 'Backlash Compensation' ...page 379

Parameter No.	Size	Name	Setting Range	Setting Unit	Default Setting	Applicable Motors	When Enabled	Classification	Reference
Pn233	2	Backlash Compensation Time Constant	0 to 65,535	0.01 ms	0	All	Immediately	Setup	↪ Chap. 9.13.9 'Backlash Compensation' ...page 379

List of Parameters > List of Parameters

Parameter No.	Size	Name	Setting Range	Setting Unit	Default Setting	Applicable Motors	When Enabled	Classification	Reference
Pn281	2	Encoder Output Resolution	1 to 4,096	1 edge/pitch	20	All	After restart	Setup	↪ Chap. 7.6.3 'Setting for the Encoder Divided Pulse Output' ...page 210

Parameter No.	Size	Name	Setting Range	Setting Unit	Default Setting	Applicable Motors	When Enabled	Classification	Reference
Pn282	2	Linear Encoder Scale Pitch	0 to 6,553,600	0.01 μm	0	Linear	After restart	Setup	↪ Chap. 6.6 'Setting the Linear Encoder Pitch' ...page 142

Parameter No.	Size	Name	Setting Range	Setting Unit	Default Setting	Applicable Motors	When Enabled	Classification	Reference
Pn304	2	Jogging Speed	0 to 10,000	1 min ⁻¹	500	Rotary	Immediately	Setup	↪ Chap. 8.4.2 'Preparations' ...page 255

Parameter No.	Size	Name	Setting Range	Setting Unit	Default Setting	Applicable Motors	When Enabled	Classification	Reference
Pn305	2	Soft Start Acceleration Time	0 to 10,000	1 ms	0	All	Immediately	Setup	*1

Parameter No.	Size	Name	Setting Range	Setting Unit	Default Setting	Applicable Motors	When Enabled	Classification	Reference
Pn306	2	Soft Start Deceleration Time	0 to 10,000	1 ms	0	All	Immediately	Setup	*1

Parameter No.	Size	Name	Setting Range	Setting Unit	Default Setting	Applicable Motors	When Enabled	Classification	Reference
Pn308	2	Speed Feedback Filter Time Constant	0 to 65,535	0.01 ms	0	All	Immediately	Setup	→ Chap. 9.14.2 'Tuning the Servo Gains' ...page 385

Parameter No.	Size	Name	Setting Range	Setting Unit	Default Setting	Applicable Motors	When Enabled	Classification	Reference
Pn30A	2	Deceleration Time for Servo OFF and Forced Stops	0 to 10,000	1 ms	0	All	Immediately	Setup	→ Chap. 6.11.4 'Motor Stopping Method for Over-travel' ...page 157

Parameter No.	Size	Name	Setting Range	Setting Unit	Default Setting	Applicable Motors	When Enabled	Classification	Reference
Pn30C	2	Speed Feed-forward Average Movement Time	0 to 5,100	0.1 ms	0	All	Immediately	Setup	→ Chap. 9.14.3 'Compatible Adjustment Functions' ...page 397

Parameter No.	Size	Name	Setting Range	Setting Unit	Default Setting	Applicable Motors	When Enabled	Classification	Reference
Pn310	2	Vibration Detection Selections	0000h to 0002h	–	0000h	All	Immediately	Setup	→ Chap. 7.12.1 'Initializing the Vibration Detection Level' ...page 236

n.□□□X	Vibration Detection Selection	
0	Do not detect vibration.	
1	Output a warning (A.911) if vibration is detected.	
2	Output an alarm (A.520) if vibration is detected.	

List of Parameters > List of Parameters

Parameter No.	Size	Name	Setting Range	Setting Unit	Default Setting	Applicable Motors	When Enabled	Classification	Reference
Pn311	2	Vibration Detection Sensitivity	50 to 500	1%	100	All	Immediately	Tuning	↪ Chap. 7.12.1 'Initializing the Vibration Detection Level' ...page 236

Parameter No.	Size	Name	Setting Range	Setting Unit	Default Setting	Applicable Motors	When Enabled	Classification	Reference
Pn312	2	Vibration Detection Level	0 to 5,000	1 min ⁻¹	50	Rotary	Immediately	Tuning	↪ Chap. 7.12.1 'Initializing the Vibration Detection Level' ...page 236

Parameter No.	Size	Name	Setting Range	Setting Unit	Default Setting	Applicable Motors	When Enabled	Classification	Reference
Pn316	2	Maximum Motor Speed	0 to 65,535	1 min ⁻¹	10000	Rotary	After restart	Setup	↪ Chap. 7.5 'Setting the Motor Maximum Speed' ...page 203

Parameter No.	Size	Name	Setting Range	Setting Unit	Default Setting	Applicable Motors	When Enabled	Classification	Reference
Pn324	2	Moment of Inertia Calculation Starting Level	0 to 20,000	1%	300	All	Immediately	Setup	↪ Chap. 9.7.6 'Troubleshooting Problems in Auto-tuning without a Host Reference' ...page 316

Parameter No.	Size	Name	Setting Range	Setting Unit	Default Setting	Applicable Motors	When Enabled	Classification	Reference
Pn383	2	Jogging Speed	0 to 10,000	1 mm/s	50	Linear	Immediately	Setup	→ Chap. 8.4.1 'Trial Operation for the Servomotor without a Load' ...page 255

Parameter No.	Size	Name	Setting Range	Setting Unit	Default Setting	Applicable Motors	When Enabled	Classification	Reference
Pn384	2	Vibration Detection Level	0 to 5,000	1 mm/s	10	Linear	Immediately	Tuning	→ Chap. 7.12.1 'Initializing the Vibration Detection Level' ...page 236

Parameter No.	Size	Name	Setting Range	Setting Unit	Default Setting	Applicable Motors	When Enabled	Classification	Reference
Pn385	2	Maximum Motor Speed	1 to 100	100 mm/s	50	Linear	After restart	Setup	→ Chap. 7.5 'Setting the Motor Maximum Speed' ...page 203

Parameter No.	Size	Name	Setting Range	Setting Unit	Default Setting	Applicable Motors	When Enabled	Classification	Reference
Pn401	2	First Stage First Torque Reference Filter Time Constant	0 to 65,535	0.01 ms	100	All	Immediately	Tuning	→ Chap. 9.14.2 'Tuning the Servo Gains' ...page 385

Parameter No.	Size	Name	Setting Range	Setting Unit	Default Setting	Applicable Motors	When Enabled	Classification	Reference
Pn402	2	Forward Torque Limit	0 to 800	1%*1	800	Rotary	Immediately	Setup	→ Chap. 7.8.2 'Internal Torque Limits' ...page 213

List of Parameters > List of Parameters

Parameter No.	Size	Name	Setting Range	Setting Unit	Default Setting	Applicable Motors	When Enabled	Classification	Reference
Pn403	2	Reverse Torque Limit	0 to 800	1%*1	800	Rotary	Immediately	Setup	↔ Chap. 7.8.2 'Internal Torque Limits' ...page 213

Parameter No.	Size	Name	Setting Range	Setting Unit	Default Setting	Applicable Motors	When Enabled	Classification	Reference
Pn404	2	Forward External Torque Limit	0 to 800	1%*1	100	All	Immediately	Setup	↔ Chap. 7.8.3 'External Torque Limits' ...page 214

Parameter No.	Size	Name	Setting Range	Setting Unit	Default Setting	Applicable Motors	When Enabled	Classification	Reference
Pn405	2	Reverse External Torque Limit	0 to 800	1%*1	100	All	Immediately	Setup	↔ Chap. 7.8.3 'External Torque Limits' ...page 214

Parameter No.	Size	Name	Setting Range	Setting Unit	Default Setting	Applicable Motors	When Enabled	Classification	Reference
Pn406	2	Emergency Stop Torque	0 to 800	1%*1	800	All	Immediately	Setup	↔ Chap. 6.11.4 'Motor Stopping Method for Over-travel' ...page 157

Parameter No.	Size	Name	Setting Range	Setting Unit	Default Setting	Applicable Motors	When Enabled	Classification	Reference
Pn407	2	Speed Limit during Torque Control	0 to 10,000	1 min ⁻¹	10000	Rotary	Immediately	Setup	↔ Chap. 7.2.11 'Speed Limit during Torque Control' ...page 199

Parameter No.	Size	Name	Setting Range	Setting Unit	Default Setting	Applicable Motors	When Enabled	Classification	Reference
Pn408	2	Torque-Related Function Selections	0000h to 1111h	–	0000h	All	–	Setup	–

n.□□□X	Notch Filter Selection 1		When Enabled	Reference
0	Disable first stage notch filter.		Immediately	↪ Chap. 9.14.2 'Tuning the Servo Gains' ...page 385
1	Enable first stage notch filter.			

n.□□□□	Speed Limit Selection		When Enabled	Reference
0	Use the smaller of the maximum motor speed and the setting of Pn407 as the speed limit.		After restart	↪ Chap. 7.2.11 'Speed Limit during Torque Control' ...page 199
	Use the smaller of the maximum motor speed and the setting of Pn480 as the speed limit.			
1	Use the smaller of the overspeed alarm detection speed and the setting of Pn407 as the speed limit.			
	Use the smaller of the overspeed alarm detection speed and the setting of Pn480 as the speed limit.			

n.□X□□	Notch Filter Selection 2		When Enabled	Reference
0	Disable second stage notch filter.		Immediately	↪ Chap. 9.14.2 'Tuning the Servo Gains' ...page 385
1	Enable second stage notch filter.			

n.X□□□	Friction Compensation Function Selection		When Enabled	Reference
0	Disable friction compensation.		Immediately	↪ Chap. 9.13.3 'Friction Compensation' ...page 374
1	Enable friction compensation.			

Parameter No.	Size	Name	Setting Range	Setting Unit	Default Setting	Applicable Motors	When Enabled	Classification	Reference
Pn409	2	First Stage Notch Filter Frequency	50 to 5,000	1 Hz	5000	All	Immediately	Tuning	↪ Chap. 9.14.2 'Tuning the Servo Gains' ...page 385

List of Parameters > List of Parameters

Parameter No.	Size	Name	Setting Range	Setting Unit	Default Setting	Applicable Motors	When Enabled	Classification	Reference
Pn40A	2	First Stage Notch Filter Q Value	50 to 1,000	0.01	70	All	Immediately	Tuning	→ Chap. 9.14.2 'Tuning the Servo Gains' ...page 385

Parameter No.	Size	Name	Setting Range	Setting Unit	Default Setting	Applicable Motors	When Enabled	Classification	Reference
Pn40B	2	First Stage Notch Filter Depth	0 to 1,000	0.001	0	All	Immediately	Tuning	→ Chap. 9.14.2 'Tuning the Servo Gains' ...page 385

Parameter No.	Size	Name	Setting Range	Setting Unit	Default Setting	Applicable Motors	When Enabled	Classification	Reference
Pn40C	2	Second Stage Notch Filter Frequency	50 to 5,000	1 Hz	5000	All	Immediately	Tuning	→ Chap. 9.14.2 'Tuning the Servo Gains' ...page 385

Parameter No.	Size	Name	Setting Range	Setting Unit	Default Setting	Applicable Motors	When Enabled	Classification	Reference
Pn40D	2	Second Stage Notch Filter Q Value	50 to 1,000	0.01	70	All	Immediately	Tuning	→ Chap. 9.14.2 'Tuning the Servo Gains' ...page 385

Parameter No.	Size	Name	Setting Range	Setting Unit	Default Setting	Applicable Motors	When Enabled	Classification	Reference
Pn40E	2	Second Stage Notch Filter Depth	0 to 1,000	0.001	0	All	Immediately	Tuning	→ Chap. 9.14.2 'Tuning the Servo Gains' ...page 385

Parameter No.	Size	Name	Setting Range	Setting Unit	Default Setting	Applicable Motors	When Enabled	Classification	Reference
Pn40F	2	Second Stage Second Torque Reference Filter Frequency	100 to 5,000	1 Hz	5000	All	Immediately	Tuning	↪ Chap. 9.14.2 'Tuning the Servo Gains' ...page 385

Parameter No.	Size	Name	Setting Range	Setting Unit	Default Setting	Applicable Motors	When Enabled	Classification	Reference
Pn410	2	Second Stage Second Torque Reference Filter Q Value	50 to 100	0.01	50	All	Immediately	Tuning	↪ Chap. 9.14.2 'Tuning the Servo Gains' ...page 385

Parameter No.	Size	Name	Setting Range	Setting Unit	Default Setting	Applicable Motors	When Enabled	Classification	Reference
Pn412	2	First Stage Second Torque Reference Filter Time Constant	0 to 65,535	0.01 ms	100	All	Immediately	Tuning	↪ Chap. 9.13.2 'Gain Switching' ...page 370

Parameter No.	Size	Name	Setting Range	Setting Unit	Default Setting	Applicable Motors	When Enabled	Classification	Reference
Pn416	2	Torque-Related Function Selections 2	0000h to 1111h	–	0000h	All	Immediately	Tuning	↪ Chap. 9.14.2 'Tuning the Servo Gains' ...page 385

n.□□□X	Notch Filter Selection 3	
0	Disable third stage notch filter.	
1	Enable third stage notch filter.	
n.□□X□	Notch Filter Selection 4	
0	Disable fourth stage notch filter.	
1	Enable fourth stage notch filter.	
n.□X□□	Notch Filter Selection 5	
0	Disable fifth stage notch filter.	
1	Enable fifth stage notch filter.	

List of Parameters > List of Parameters

Parameter No.	Size	Name	Setting Range	Setting Unit	Default Setting	Applicable Motors	When Enabled	Classification	Reference
Pn417	2	Third Stage Notch Filter Frequency	50 to 5,000	1 Hz	5000	All	Immediately	Tuning	→ Chap. 9.14.2 'Tuning the Servo Gains' ...page 385

Parameter No.	Size	Name	Setting Range	Setting Unit	Default Setting	Applicable Motors	When Enabled	Classification	Reference
Pn418	2	Third Stage Notch Filter Q Value	50 to 1,000	0.01	70	All	Immediately	Tuning	→ Chap. 9.14.2 'Tuning the Servo Gains' ...page 385

Parameter No.	Size	Name	Setting Range	Setting Unit	Default Setting	Applicable Motors	When Enabled	Classification	Reference
Pn419	2	Third Stage Notch Filter Depth	0 to 1,000	0.001	0	All	Immediately	Tuning	→ Chap. 9.14.2 'Tuning the Servo Gains' ...page 385

Parameter No.	Size	Name	Setting Range	Setting Unit	Default Setting	Applicable Motors	When Enabled	Classification	Reference
Pn41A	2	Fourth Stage Notch Filter Frequency	50 to 5,000	1 Hz	5000	All	Immediately	Tuning	→ Chap. 9.14.2 'Tuning the Servo Gains' ...page 385

Parameter No.	Size	Name	Setting Range	Setting Unit	Default Setting	Applicable Motors	When Enabled	Classification	Reference
Pn41B	2	Fourth Stage Notch Filter Q Value	50 to 1,000	0.01	70	All	Immediately	Tuning	→ Chap. 9.14.2 'Tuning the Servo Gains' ...page 385

Parameter No.	Size	Name	Setting Range	Setting Unit	Default Setting	Applicable Motors	When Enabled	Classification	Reference
Pn41C	2	Fourth Stage Notch Filter Depth	0 to 1,000	0.001	0	All	Immediately	Tuning	→ Chap. 9.14.2 'Tuning the Servo Gains' ...page 385

Parameter No.	Size	Name	Setting Range	Setting Unit	Default Setting	Applicable Motors	When Enabled	Classification	Reference
Pn41D	2	Fifth Stage Notch Filter Frequency	50 to 5,000	1 Hz	5000	All	Immediately	Tuning	→ Chap. 9.14.2 'Tuning the Servo Gains' ...page 385

Parameter No.	Size	Name	Setting Range	Setting Unit	Default Setting	Applicable Motors	When Enabled	Classification	Reference
Pn41E	2	Fifth Stage Notch Filter Q Value	50 to 1,000	0.01	70	All	Immediately	Tuning	→ Chap. 9.14.2 'Tuning the Servo Gains' ...page 385

Parameter No.	Size	Name	Setting Range	Setting Unit	Default Setting	Applicable Motors	When Enabled	Classification	Reference
Pn41F	2	Fifth Stage Notch Filter Depth	0 to 1,000	0.001	0	All	Immediately	Tuning	→ Chap. 9.14.2 'Tuning the Servo Gains' ...page 385

Parameter No.	Size	Name	Setting Range	Setting Unit	Default Setting	Applicable Motors	When Enabled	Classification	Reference
Pn423	2	Speed Ripple Compensation Selections	0000h to 1111h	–	0000h	Rotary	–	Setup	→ Chap. 9.12.3 'Setting Up Speed Ripple Compensation' ...page 362

n.□□□X	Speed Ripple Compensation Function Selection	When Enabled
0	Disable speed ripple compensation.	Immediately
1	Enable speed ripple compensation.	

List of Parameters > List of Parameters

n.□□X□	Speed Ripple Compensation Information Disagreement Warning Detection Selection	When Enabled
0	Detect A.942 alarms.	After restart
1	Do not detect A.942 alarms.	

n.□X□□	Speed Ripple Compensation Enable Condition Selection	When Enabled
0	Speed reference	After restart
1	Motor speed	

Parameter No.	Size	Name	Setting Range	Setting Unit	Default Setting	Applicable Motors	When Enabled	Classification	Reference
Pn424	2	Torque Limit at Main Circuit Voltage Drop	0 to 100	1%*1	50	All	Immediately	Setup	↪ Chap. 7.4 'SEMI F47 Function' ...page 201

Parameter No.	Size	Name	Setting Range	Setting Unit	Default Setting	Applicable Motors	When Enabled	Classification	Reference
Pn425	2	Release Time for Torque Limit at Main Circuit Voltage Drop	0 to 1,000	1 ms	100	All	Immediately	Setup	↪ Chap. 7.4 'SEMI F47 Function' ...page 201

Parameter No.	Size	Name	Setting Range	Setting Unit	Default Setting	Applicable Motors	When Enabled	Classification	Reference
Pn426	2	Torque Feed-forward Average Movement Time	0 to 5,100	0.1 ms	0	All	Immediately	Setup	↪ Chap. 9.14.3 'Compatible Adjustment Functions' ...page 397

Parameter No.	Size	Name	Setting Range	Setting Unit	Default Setting	Applicable Motors	When Enabled	Classification	Reference
Pn427	2	Speed Ripple Compensation Enable Speed	0 to 10,000	1 min ⁻¹	0	Rotary	Immediately	Tuning	↪ Chap. 9.12.3 'Setting Up Speed Ripple Compensation' ...page 362

Parameter No.	Size	Name	Setting Range	Setting Unit	Default Setting	Applicable Motors	When Enabled	Classification	Reference
Pn456	2	Sweep Torque Reference Amplitude	1 to 800	1%	15	All	Immediately	Tuning	→ Chap. 9.15.2 'Easy FFT' ...page 403

Parameter No.	Size	Name	Setting Range	Setting Unit	Default Setting	Applicable Motors	When Enabled	Classification	Reference
Pn460	2	Notch Filter Adjustment Selections 1	0000h to 0101h	–	0101h	All	Immediately	Tuning	→ Chap. 9.5.1 'Tuning-less Function' ...page 290, → Chap. 9.7.1 'Auto-tuning without Host Reference' ...page 306, → Chap. 9.9.1 'Custom Tuning' ...page 332

n.□□□X	Notch Filter Adjustment Selection 1	
	0	Do not adjust the first stage notch filter automatically during execution of autotuning without a host reference, autotuning with a host reference, and custom tuning.
	1	Adjust the first stage notch filter automatically during execution of autotuning without a host reference, autotuning with a host reference, and custom tuning.

n.□X□□	Notch Filter Adjustment Selection 2	
	0	Do not adjust the second stage notch filter automatically when the tuning-less function is enabled or during execution of autotuning without a host reference, autotuning with a host reference, and custom tuning.
	1	Adjust the second stage notch filter automatically when the tuning-less function is enabled or during execution of autotuning without a host reference, autotuning with a host reference, and custom tuning.

List of Parameters > List of Parameters

Parameter No.	Size	Name	Setting Range	Setting Unit	Default Setting	Applicable Motors	When Enabled	Classification	Reference
Pn475	2	Gravity Compensation-Related Selections	0000h to 0001h	–	0000h	All	After restart	Setup	→ Chap. 9.13.4 'Gravity Compensation' ...page 376

n.□□□X	Gravity Compensation Selection
0	Disable gravity compensation.
1	Enable gravity compensation.

Parameter No.	Size	Name	Setting Range	Setting Unit	Default Setting	Applicable Motors	When Enabled	Classification	Reference
Pn476	2	Gravity Compensation Torque	-1,000 to 1,000	0.1%	0000h	All	Immediately	Tuning	→ Chap. 9.13.4 'Gravity Compensation' ...page 376

Parameter No.	Size	Name	Setting Range	Setting Unit	Default Setting	Applicable Motors	When Enabled	Classification	Reference
Pn480	2	Speed Limit during Force Control	0 to 10,000	1 mm/s	10000	Linear	Immediately	Setup	→ Chap. 7.2.11 'Speed Limit during Torque Control' ...page 199

Parameter No.	Size	Name	Setting Range	Setting Unit	Default Setting	Applicable Motors	When Enabled	Classification	Reference
Pn481	2	Polarity Detection Speed Loop Gain	10 to 20,000	0.1 Hz	400	Linear	Immediately	Tuning	–

Parameter No.	Size	Name	Setting Range	Setting Unit	Default Setting	Applicable Motors	When Enabled	Classification	Reference
Pn482	2	Polarity Detection Speed Loop Integral Time Constant	15 to 51,200	0.01 ms	3000	Linear	Immediately	Tuning	–

Parameter No.	Size	Name	Setting Range	Setting Unit	Default Setting	Applicable Motors	When Enabled	Classification	Reference
Pn483	2	Forward Force Limit	0 to 800	1%*1	30	Linear	Immediately	Setup	→ Chap. 7.8.2 'Internal Torque Limits' ...page 213

Parameter No.	Size	Name	Setting Range	Setting Unit	Default Setting	Applicable Motors	When Enabled	Classification	Reference
Pn484	2	Reverse Force Limit	0 to 800	1%*1	30	Linear	Immediately	Setup	→ Chap. 7.8.2 'Internal Torque Limits' ...page 213

Parameter No.	Size	Name	Setting Range	Setting Unit	Default Setting	Applicable Motors	When Enabled	Classification	Reference
Pn485	2	Polarity Detection Reference Speed	0 to 100	1 mm/s	20	Linear	Immediately	Tuning	–

Parameter No.	Size	Name	Setting Range	Setting Unit	Default Setting	Applicable Motors	When Enabled	Classification	Reference
Pn486	2	Polarity Detection Reference Acceleration/Deceleration Time	0 to 100	1 ms	25	Linear	Immediately	Tuning	–

Parameter No.	Size	Name	Setting Range	Setting Unit	Default Setting	Applicable Motors	When Enabled	Classification	Reference
Pn487	2	Polarity Detection Constant Speed Time	0 to 300	1 ms	0	Linear	Immediately	Tuning	–

Parameter No.	Size	Name	Setting Range	Setting Unit	Default Setting	Applicable Motors	When Enabled	Classification	Reference
Pn488	2	Polarity Detection Reference Waiting Time	50 to 500	1 ms	100	Linear	Immediately	Tuning	–

List of Parameters > List of Parameters

Parameter No.	Size	Name	Setting Range	Setting Unit	Default Setting	Applicable Motors	When Enabled	Classification	Reference
Pn48E	2	Polarity Detection Range	1 to 65,535	1 mm	10	Linear	Immediately	Tuning	–

Parameter No.	Size	Name	Setting Range	Setting Unit	Default Setting	Applicable Motors	When Enabled	Classification	Reference
Pn490	2	Polarity Detection Load Level	0 to 20,000	1%	100	Linear	Immediately	Tuning	–

Parameter No.	Size	Name	Setting Range	Setting Unit	Default Setting	Applicable Motors	When Enabled	Classification	Reference
Pn495	2	Polarity Detection Confirmation Force Reference	0 to 200	1%	100	Linear	Immediately	Tuning	–

Parameter No.	Size	Name	Setting Range	Setting Unit	Default Setting	Applicable Motors	When Enabled	Classification	Reference
Pn498	2	Polarity Detection Allowable Error Range	0 to 30	1 deg	10	Linear	Immediately	Tuning	–

Parameter No.	Size	Name	Setting Range	Setting Unit	Default Setting	Applicable Motors	When Enabled	Classification	Reference
Pn49F	2	Speed Ripple Compensation Enable Speed	0 to 10,000	1 mm/s	0	Linear	Immediately	Tuning	↪ Chap. 9.12.1 'Speed Ripple Compensation' ...page 361

Parameter No.	Size	Name	Setting Range	Setting Unit	Default Setting	Applicable Motors	When Enabled	Classification	Reference
Pn502	2	Rotation Detection Level	1 to 10,000	1 min ⁻¹	20	Rotary	Immediately	Setup	↪ Chap. 7.2.6 'TGON (Rotation Detection) Signal' ...page 193

Parameter No.	Size	Name	Setting Range	Setting Unit	Default Setting	Applicable Motors	When Enabled	Classification	Reference
Pn503	2	Speed Coincidence Detection Signal Output Width	0 to 100	1 min ⁻¹	10	Rotary	Immediately	Setup	↪ Chap. 7.2.8 'V-CMP (Speed Coincidence Detection) Signal' ...page 195

Parameter No.	Size	Name	Setting Range	Setting Unit	Default Setting	Applicable Motors	When Enabled	Classification	Reference
Pn506	2	Brake Reference-Servo OFF Delay Time	0 to 50	10 ms	0*5	All	Immediately	Setup	↪ Chap. 6.12.2 'Brake Operating Sequence' ...page 162

Parameter No.	Size	Name	Setting Range	Setting Unit	Default Setting	Applicable Motors	When Enabled	Classification	Reference
Pn507	2	Brake Reference Output Speed Level	0 to 10,000	1 min ⁻¹	100	Rotary	Immediately	Setup	↪ Chap. 6.12.2 'Brake Operating Sequence' ...page 162

Parameter No.	Size	Name	Setting Range	Setting Unit	Default Setting	Applicable Motors	When Enabled	Classification	Reference
Pn508	2	Servo OFF-Brake Command Waiting Time	10 to 100	10 ms	50	All	Immediately	Setup	↪ Chap. 6.12.2 'Brake Operating Sequence' ...page 162

List of Parameters > List of Parameters

Parameter No.	Size	Name	Setting Range	Setting Unit	Default Setting	Applicable Motors	When Enabled	Classification	Reference
Pn509	2	Momentary Power Interruption Hold Time	20 to 50,000	1 ms	20	All	Immediately	Setup	↪ Chap. 7.3 'Operation for Momentary Power Interruptions' ...page 200

Parameter No.	Size	Name	Setting Range	Setting Unit	Default Setting	Applicable Motors	When Enabled	Classification	Reference
Pn50A	2	Input Signal Selections 1	0000h to FFF2h	–	1881h	All	After restart	Setup	–

n.X□□□	P-OT (Forward Drive Prohibit) Signal Allocation		Reference
0	Enable forward drive when CN1-13 input signal is ON (closed).	↪ Chap. 6.11.2 'Overtravel Signals' ...page 156	
1	Enable forward drive when CN1-7 input signal is ON (closed).		
2	Enable forward drive when CN1-8 input signal is ON (closed).		
3	Enable forward drive when CN1-9 input signal is ON (closed).		
4	Enable forward drive when CN1-10 input signal is ON (closed).		
5	Enable forward drive when CN1-11 input signal is ON (closed).		
6	Enable forward drive when CN1-12 input signal is ON (closed).		
7	Set the signal to always prohibit forward drive.		
8	Set the signal to always enable forward drive.		
9	Enable forward drive when CN1-13 input signal is OFF (open).		
A	Enable forward drive when CN1-7 input signal is OFF (open).		
B	Enable forward drive when CN1-8 input signal is OFF (open).		
C	Enable forward drive when CN1-9 input signal is OFF (open).		
D	Enable forward drive when CN1-10 input signal is OFF (open).		
E	Enable forward drive when CN1-11 input signal is OFF (open).		
F	Enable forward drive when CN1-12 input signal is OFF (open).		

Parameter No.	Size	Name	Setting Range	Setting Unit	Default Setting	Applicable Motors	When Enabled	Classification	Reference
Pn50B	2	Input Signal Selections 2	0000h to FFFFh	–	8882h	All	After restart	Setup	–

n.□□□X	N-OT (Reverse Drive Prohibit) Signal Allocation		Reference
0	Enable reverse drive when CN1-13 input signal is ON (closed).	↪ Chap. 6.11.2 'Overtravel Signals' ...page 156	
1	Enable reverse drive when CN1-7 input signal is ON (closed).		
2	Enable reverse drive when CN1-8 input signal is ON (closed).		
3	Enable reverse drive when CN1-9 input signal is ON (closed).		
4	Enable reverse drive when CN1-10 input signal is ON (closed).		
5	Enable reverse drive when CN1-11 input signal is ON (closed).		
6	Enable reverse drive when CN1-12 input signal is ON (closed).		
7	Set the signal to always prohibit reverse drive.		
8	Set the signal to always enable reverse drive.		
9	Enable reverse drive when CN1-13 input signal is OFF (open).		
A	Enable reverse drive when CN1-7 input signal is OFF (open).		
B	Enable reverse drive when CN1-8 input signal is OFF (open).		
C	Enable reverse drive when CN1-9 input signal is OFF (open).		
D	Enable reverse drive when CN1-10 input signal is OFF (open).		
E	Enable reverse drive when CN1-11 input signal is OFF (open).		
F	Enable reverse drive when CN1-12 input signal is OFF (open).		

n.□X□□	/P-CL (Forward External Torque Limit Input) Signal Allocation		Reference
0	Active when CN1-13 input signal is ON (closed).	↪ Chap. 7.8.3 'External Torque Limits' ...page 214	
1	Active when CN1-7 input signal is ON (closed).		
2	Active when CN1-8 input signal is ON (closed).		
3	Active when CN1-9 input signal is ON (closed).		
4	Active when CN1-10 input signal is ON (closed).		
5	Active when CN1-11 input signal is ON (closed).		
6	Active when CN1-12 input signal is ON (closed).		

n.□X□□	/P-CL (Forward External Torque Limit Input) Signal Allocation		Reference
	7	The signal is always active.	
	8	The signal is always inactive.	
	9	Active when CN1-13 input signal is OFF (open).	
	A	Active when CN1-7 input signal is OFF (open).	
	B	Active when CN1-8 input signal is OFF (open).	
	C	Active when CN1-9 input signal is OFF (open).	
	D	Active when CN1-10 input signal is OFF (open).	
	E	Active when CN1-11 input signal is OFF (open).	
	F	Active when CN1-12 input signal is OFF (open).	
n.X□□□	/N-CL (Reverse External Torque Limit Input) Signal Allocation		Reference
	0 to F	The allocations are the same as the /P-CL (Forward External Torque Limit Input) signal allocations.	↪ Chap. 7.8.3 'External Torque Limits' ...page 214

Parameter No.	Size	Name	Setting Range	Setting Unit	Default Setting	Applicable Motors	When Enabled	Classification	Reference
Pn50E	2	Output Signal Selections 1	0000h to 6666h	–	0000h	All	After restart	Setup	–

n.□□□X	/COIN (Positioning Completion Output) Signal Allocation		Reference
	0	Disabled (the above signal output is not used).	↪ Chap. 7.2.9 '/COIN (Positioning Completion) Signal' ...page 196
	1	Output the signal from the CN1-1 or CN1-2 output terminal.	
	2	Output the signal from the CN1-23 or CN1-24 output terminal.	
	3	Output the signal from the CN1-25 or CN1-26 output terminal.	
	4 to 6	Reserved setting (Do not use.)	
n.□□X□	/V-CMP (Speed Coincidence Detection Output) Signal Allocation		Reference
	0 to 6	The allocations are the same as the /COIN (Positioning Completion) signal allocations.	↪ Chap. 7.2.8 '/V-CMP (Speed Coincidence Detection) Signal' ...page 195

n.□X□□	/TGON (Rotation Detection Output) Signal Allocation		Reference
	0 to 6	The allocations are the same as the /COIN (Positioning Completion) signal allocations.	↪ Chap. 7.2.6 ' /TGON (Rotation Detection) Signal' ...page 193

n.X□□□	/S-RDY (Servo Ready) Signal Allocation		Reference
	0 to 6	The allocations are the same as the /COIN (Positioning Completion) signal allocations.	↪ Chap. 7.2.6 ' /TGON (Rotation Detection) Signal' ...page 193

Parameter No.	Size	Name	Setting Range	Setting Unit	Default Setting	Applicable Motors	When Enabled	Classification	Reference
Pn50F	2	Output Signal Selections 2	0000h to 6666h	–	0100h	All	After restart	Setup	–

n.□□□X	/CLT (Torque Limit Detection Output) Signal Allocation		Reference
	0	Disabled (the above signal output is not used).	↪ Chap. 7.8.4 ' /CLT (Torque Limit Detection) Signal' ...page 218
	1	Output the signal from the CN1-1 or CN1-2 output terminal.	
	2	Output the signal from the CN1-23 or CN1-24 output terminal.	
	3	Output the signal from the CN1-25 or CN1-26 output terminal.	
	4 to 6	Reserved setting (Do not use.)	

n.□□X□	/VLT (Speed Limit Detection) Signal Allocation		Reference
	0 to 6	The allocations are the same as the /CLT (Torque Limit Detection Output) signal allocations.	↪ ' /VLT (Speed Limit Detection) Signal' ...page 199

n.□X□□	/BK (Brake Output) Signal Allocation		Reference
	0 to 6	The allocations are the same as the /CLT (Torque Limit Detection Output) signal allocations.	↪ Chap. 6.12.1 'Holding Brake' ...page 161

n.X□□□	/WARN (Warning Output) Signal Allocation		Reference
	0 to 6	The allocations are the same as the /CLT (Torque Limit Detection Output) signal allocations.	↪ Chap. 7.2.5 ' /WARN (Warning) Signal' ...page 192

List of Parameters > List of Parameters

Parameter No.	Size	Name	Setting Range	Setting Unit	Default Setting	Applicable Motors	When Enabled	Classification	Reference
Pn510	2	Output Signal Selections 3	0000h to 0666h	–	0000h	All	After restart	Setup	–

n.□□□X	/NEAR (Near Output) Signal Allocation		Reference
0	Disabled (the above signal output is not used).		↪ Chap. 7.2.10 'NEAR (Near) Signal' ...page 197
1	Output the signal from the CN1-1 or CN1-2 output terminal.		
2	Output the signal from the CN1-23 or CN1-24 output terminal.		
3	Output the signal from the CN1-25 or CN1-26 output terminal.		
4 to 6	Reserved setting (Do not use.)		

Parameter No.	Size	Name	Setting Range	Setting Unit	Default Setting	Applicable Motors	When Enabled	Classification	Reference
Pn511	2	Input Signal Selections 5	0000h to FFFFh	–	8543h	All	After restart	Setup	↪ Chap. 7.2.2 'Input Signal Allocations' ...page 189

n.□□□X	/DEC (Home Switch Input) Signal Allocation	
0	Active when CN1-13 input signal is ON (closed).	
1	Active when CN1-7 input signal is ON (closed).	
2	Active when CN1-8 input signal is ON (closed).	
3	Active when CN1-9 input signal is ON (closed).	
4	Active when CN1-10 input signal is ON (closed).	
5	Active when CN1-11 input signal is ON (closed).	
6	Active when CN1-12 input signal is ON (closed).	
7	The signal is always active.	
8	The signal is always inactive.	
9	Active when CN1-13 input signal is OFF (open).	
A	Active when CN1-7 input signal is OFF (open).	
B	Active when CN1-8 input signal is OFF (open).	
C	Active when CN1-9 input signal is OFF (open).	
D	Active when CN1-10 input signal is OFF (open).	
E	Active when CN1-11 input signal is OFF (open).	
F	Active when CN1-12 input signal is OFF (open).	

n.□□X□	/EXT1 (Probe 1 Latch Input) Signal Allocation	
	0	The signal is always inactive.
	1	The signal is always inactive.
	2	The signal is always inactive.
	3	The signal is always inactive.
	4	Active when CN1-10 input signal is ON (closed).
	5	Active when CN1-11 input signal is ON (closed).
	6	Active when CN1-12 input signal is ON (closed).
	7	The signal is always inactive.
	8	The signal is always inactive.
	9	The signal is always inactive.
	A	The signal is always inactive.
	B	The signal is always inactive.
	C	The signal is always inactive.
	D	Active when CN1-10 input signal is OFF (open).
	E	Active when CN1-11 input signal is OFF (open).
	F	Active when CN1-12 input signal is OFF (open).
n.□X□□	/EXT2 (Probe 2 Latch Input) Signal Allocation	
	0 to F	The allocations are the same as the /EXT1 (Probe 1 Latch Input) signal allocations.
n.X□□□	Reserved parameter (Do not change.)*4	
	8	Reserved parameter (Do not change.) (Automatically set by the PROFINET Module.)

Parameter No.	Size	Name	Setting Range	Setting Unit	Default Setting	Applicable Motors	When Enabled	Classification	Reference
Pn512	2	Output Signal Inverse Settings 1	0000h to 1111h	–	0000h	All	After restart	Setup	↔ Chap. 7.2.3 'Output Signal Allocations' ...page 190

n.□□X□	Output Signal Inversion for CN1-1 and CN1-2 Terminals	
	0	The signal is not inverted.
	1	The signal is inverted.
n.□□X□	Output Signal Inversion for CN1-23 and CN1-24 Terminals	
	0	The signal is not inverted.
	1	The signal is inverted.

n.□X□□	Output Signal Inversion for CN1-25 and CN1-26 Terminals	
0	The signal is not inverted.	
1	The signal is inverted.	

Parameter No.	Size	Name	Setting Range	Setting Unit	Default Setting	Applicable Motors	When Enabled	Classification	Reference
Pn514	2	Output Signal Selections 4	0000h to 0666h	–	0000h	All	After restart	Setup	–

n.□X□□	/PM (Preventative Maintenance Output) Signal Allocation		Reference
0	Disabled (the above signal output is not used).		↪ Chap. 10.5.3 'Preventative Maintenance' ...page 426
1	Output the signal from the CN1-1 or CN1-2 output terminal.		
2	Output the signal from the CN1-23 or CN1-24 output terminal.		
3	Output the signal from the CN1-25 or CN1-26 output terminal.		
4 to 6	Reserved setting (Do not use.)		

Parameter No.	Size	Name	Setting Range	Setting Unit	Default Setting	Applicable Motors	When Enabled	Classification	Reference
Pn516	2	Input Signal Selections 7	0000h to FFFFh	–	8888h	All	After restart	Setup	–

n.□□□X	FSTP (Forced Stop Input) Signal Allocation		Reference
0	Enable drive when CN1-13 input signal is ON (closed).		↪ Chap. 7.14.1 'Forcing the Motor to Stop' ...page 245
1	Enable drive when CN1-7 input signal is ON (closed).		
2	Enable drive when CN1-8 input signal is ON (closed).		
3	Enable drive when CN1-9 input signal is ON (closed).		
4	Enable drive when CN1-10 input signal is ON (closed).		
5	Enable drive when CN1-11 input signal is ON (closed).		
6	Enable drive when CN1-12 input signal is ON (closed).		
7	Set the signal to always prohibit drive (always force the motor to stop).		
8	Set the signal to always enable drive (always disable forcing the motor to stop).		
9	Enable drive when CN1-13 input signal is OFF (open).		

n.□□□X	FSTP (Forced Stop Input) Signal Allocation		Reference
	A	Enable drive when CN1-7 input signal is OFF (open).	
	B	Enable drive when CN1-8 input signal is OFF (open).	
	C	Enable drive when CN1-9 input signal is OFF (open).	
	D	Enable drive when CN1-10 input signal is OFF (open).	
	E	Enable drive when CN1-11 input signal is OFF (open).	
	F	Enable drive when CN1-12 input signal is OFF (open).	

Parameter No.	Size	Name	Setting Range	Setting Unit	Default Setting	Applicable Motors	When Enabled	Classification	Reference
Pn518 ⁴	–	Safety Module-Related Parameters	–	–	–	All	–	–	–

Parameter No.	Size	Name	Setting Range	Setting Unit	Default Setting	Applicable Motors	When Enabled	Classification	Reference
Pn51B	4	Motor-Load Position Deviation Overflow Detection Level	0 to 1,073,741,823	1 reference unit	1000	Rotary	Immediately	Setup	↪ Chap. 11.4.8 'Alarm Detection Settings' ...page 436

Parameter No.	Size	Name	Setting Range	Setting Unit	Default Setting	Applicable Motors	When Enabled	Classification	Reference
Pn51E	2	Position Deviation Overflow Warning Level	10 to 100	1%	100	All	Immediately	Setup	↪ Chap. 16.5.2.3 'List of the SERVOPACK Warnings' ...page 601

List of Parameters > List of Parameters

Parameter No.	Size	Name	Setting Range	Setting Unit	Default Setting	Applicable Motors	When Enabled	Classification	Reference
Pn520	4	Position Deviation Overflow Alarm Level	1 to 1,073,741,823	1 reference unit	5242880	All	Immediately	Setup	↪ Chap. 9.4.4 'Setting the Position Deviation Overflow Alarm Level' ...page 287, ↪ Chap. 16.4.2.1 'List of Alarms' ...page 552

Parameter No.	Size	Name	Setting Range	Setting Unit	Default Setting	Applicable Motors	When Enabled	Classification	Reference
Pn522	4	Positioning Completed Width	0 to 1,073,741,824	1 reference unit	7	All	Immediately	Setup	↪ Chap. 7.2.9 'COIN (Positioning Completion) Signal' ...page 196

Parameter No.	Size	Name	Setting Range	Setting Unit	Default Setting	Applicable Motors	When Enabled	Classification	Reference
Pn524	4	Near Signal Width	1 to 1,073,741,824	1 reference unit	1073741824	All	Immediately	Setup	↪ Chap. 7.2.10 'NEAR (Near) Signal' ...page 197

Parameter No.	Size	Name	Setting Range	Setting Unit	Default Setting	Applicable Motors	When Enabled	Classification	Reference
Pn526	4	Position Deviation Overflow Alarm Level at Servo ON	1 to 1,073,741,823	1 reference unit	5242880	All	Immediately	Setup	↪ Chap. 9.4.6 'Setting the Position Deviation Overflow Alarm Level at Servo ON' ...page 289

Parameter No.	Size	Name	Setting Range	Setting Unit	Default Setting	Applicable Motors	When Enabled	Classification	Reference
Pn528	2	Position Deviation Overflow Warning Level at Servo ON	10 to 100	1%	100	All	Immediately	Setup	↪ Chap. 9.4.6 'Setting the Position Deviation Overflow Alarm Level at Servo ON' ...page 289

Parameter No.	Size	Name	Setting Range	Setting Unit	Default Setting	Applicable Motors	When Enabled	Classification	Reference
Pn529	2	Speed Limit Level at Servo ON	0 to 10,000	1 min ⁻¹	10000	Rotary	Immediately	Setup	↪ Chap. 9.4.6 'Setting the Position Deviation Overflow Alarm Level at Servo ON' ...page 289

Parameter No.	Size	Name	Setting Range	Setting Unit	Default Setting	Applicable Motors	When Enabled	Classification	Reference
Pn52A	2	Multiplier per Fully-closed Rotation	0 to 100	1%	20	Rotary	Immediately	Setup	↪ Chap. 11.4.8 'Alarm Detection Settings' ...page 436

Parameter No.	Size	Name	Setting Range	Setting Unit	Default Setting	Applicable Motors	When Enabled	Classification	Reference
Pn52B	2	Overload Warning Level	1 to 100	1%	20	All	Immediately	Setup	↪ Chap. 6.14.2 'Detection Timing for Overload Warnings (A.910)' ...page 170

List of Parameters > List of Parameters

Parameter No.	Size	Name	Setting Range	Setting Unit	Default Setting	Applicable Motors	When Enabled	Classification	Reference
Pn52C	2	Base Current Derating at Motor Overload Detection	10 to 100	1%	100	All	After restart	Setup	↪ Chap. 6.14.2 'Detection Timing for Overload Warnings (A.910)' ...page 170

Parameter No.	Size	Name	Setting Range	Setting Unit	Default Setting	Applicable Motors	When Enabled	Classification	Reference
Pn530	2	Program Jogging- Related Selections	0000h to 0005h	–	0000h	All	Immediately	Setup	↪ Chap. 8.7.2 'Program Jogging' ...page 264

n.□□□X	Program Jogging Operation Pattern
0	(Waiting time in Pn535 → Forward by travel distance in Pn531) × Number of movements in Pn536
1	(Waiting time in Pn535 → Reverse by travel distance in Pn531) × Number of movements in Pn536
2	(Waiting time in Pn535 → Forward by travel distance in Pn531) × Number of movements in Pn536 (Waiting time in Pn535 → Reverse by travel distance in Pn531) × Number of movements in Pn536
3	(Waiting time in Pn535 → Reverse by travel distance in Pn531) × Number of movements in Pn536 (Waiting time in Pn535 → Forward by travel distance in Pn531) × Number of movements in Pn536
4	(Waiting time in Pn535 → Forward by travel distance in Pn531 → Waiting time in Pn535 → Reverse by travel distance in Pn531) × Number of movements in Pn536
5	(Waiting time in Pn535 → Reverse by travel distance in Pn531 → Waiting time in Pn535 → Forward by travel distance in Pn531) × Number of movements in Pn536

Parameter No.	Size	Name	Setting Range	Setting Unit	Default Setting	Applicable Motors	When Enabled	Classification	Reference
Pn531	4	Program Jogging Travel Distance	1 to 1,073,741,824	1 reference unit	32768	All	Immediately	Setup	↪ Chap. 8.7.2 'Program Jogging' ...page 264

Parameter No.	Size	Name	Setting Range	Setting Unit	Default Setting	Applicable Motors	When Enabled	Classification	Reference
Pn533	2	Program Jogging Movement Speed	1 to 10,000	Rotary: 1 min ⁻¹ Direct Drive: 0.1 min ⁻¹	500	Rotary	Immediately	Setup	↪ Chap. 8.7.2 'Program Jogging' ...page 264

Parameter No.	Size	Name	Setting Range	Setting Unit	Default Setting	Applicable Motors	When Enabled	Classification	Reference
Pn534	2	Program Jogging Acceleration/ Deceleration Time	2 to 10,000	1 ms	100	All	Immediately	Setup	↪ Chap. 8.7.2 'Program Jogging' ...page 264

Parameter No.	Size	Name	Setting Range	Setting Unit	Default Setting	Applicable Motors	When Enabled	Classification	Reference
Pn535	2	Program Jogging Waiting Time	0 to 10,000	1 ms	100	All	Immediately	Setup	↪ Chap. 8.7.2 'Program Jogging' ...page 264

Parameter No.	Size	Name	Setting Range	Setting Unit	Default Setting	Applicable Motors	When Enabled	Classification	Reference
Pn536	2	Program Jogging Number of Movements	0 to 1,000	1 time	1	All	Immediately	Setup	↪ Chap. 8.7.2 'Program Jogging' ...page 264

Parameter No.	Size	Name	Setting Range	Setting Unit	Default Setting	Applicable Motors	When Enabled	Classification	Reference
Pn550	2	Analog Monitor 1 Offset Voltage	-10,000 to 10,000	0.1 V	0	All	Immediately	Setup	↪ Chap. 10.4.1 'Monitoring Machine Operation Status and Signal Waveforms' ...page 415

List of Parameters > List of Parameters

Parameter No.	Size	Name	Setting Range	Setting Unit	Default Setting	Applicable Motors	When Enabled	Classification	Reference
Pn551	2	Analog Monitor 2 Offset Voltage	-10,000 to 10,000	0.1 V	0	All	Immediately	Setup	→ Chap. 10.4.1 'Monitoring Machine Operation Status and Signal Waveforms' ...page 415

Parameter No.	Size	Name	Setting Range	Setting Unit	Default Setting	Applicable Motors	When Enabled	Classification	Reference
Pn552	2	Analog Monitor 1 Magnification	-10,000 to 10,000	× 0.01	100	All	Immediately	Setup	→ Chap. 10.4.1 'Monitoring Machine Operation Status and Signal Waveforms' ...page 415

Parameter No.	Size	Name	Setting Range	Setting Unit	Default Setting	Applicable Motors	When Enabled	Classification	Reference
Pn553	2	Analog Monitor 2 Magnification	-10,000 to 10,000	× 0.01	100	All	Immediately	Setup	→ Chap. 10.4.1 'Monitoring Machine Operation Status and Signal Waveforms' ...page 415

Parameter No.	Size	Name	Setting Range	Setting Unit	Default Setting	Applicable Motors	When Enabled	Classification	Reference
Pn55A	2	Power Consumption Monitor Unit Time	1 to 1,440	1 min	1	All	Immediately	Setup	–

Parameter No.	Size	Name	Setting Range	Setting Unit	Default Setting	Applicable Motors	When Enabled	Classification	Reference
Pn560	2	Residual Vibration Detection Width	1 to 3,000	0.1%	400	All	Immediately	Setup	→ Chap. 9.11.1 'Vibration Suppression' ...page 355

Parameter No.	Size	Name	Setting Range	Setting Unit	Default Setting	Applicable Motors	When Enabled	Classification	Reference
Pn561	2	Overshoot Detection Level	0 to 100	1%	100	All	Immediately	Setup	→ Chap. 9.7.1 'Auto-tuning without Host Reference' ...page 306, → Chap. 9.8.1 'Auto-tuning with a Host Reference' ...page 322

Parameter No.	Size	Name	Setting Range	Setting Unit	Default Setting	Applicable Motors	When Enabled	Classification	Reference
Pn581	2	Zero Speed Level	1 to 10,000	1 mm/s	20	Linear	Immediately	Setup	→ Chap. 7.2.6 'TGON (Rotation Detection) Signal' ...page 193

Parameter No.	Size	Name	Setting Range	Setting Unit	Default Setting	Applicable Motors	When Enabled	Classification	Reference
Pn582	2	Speed Coincidence Detection Signal Output Width	0 to 100	1 mm/s	10	Linear	Immediately	Setup	→ Chap. 7.2.8 'V-CMP (Speed Coincidence Detection) Signal' ...page 195

List of Parameters > List of Parameters

Parameter No.	Size	Name	Setting Range	Setting Unit	Default Setting	Applicable Motors	When Enabled	Classification	Reference
Pn583	2	Brake Reference Output Speed Level	0 to 10,000	1 mm/s	10	Linear	Immediately	Setup	↪ Chap. 6.12.1 'Holding Brake' ...page 161

Parameter No.	Size	Name	Setting Range	Setting Unit	Default Setting	Applicable Motors	When Enabled	Classification	Reference
Pn584	2	Speed Limit Level at Servo ON	0 to 10,000	1 mm/s	10000	Linear	Immediately	Setup	↪ Chap. 9.4.6 'Setting the Position Deviation Overflow Alarm Level at Servo ON' ...page 289

Parameter No.	Size	Name	Setting Range	Setting Unit	Default Setting	Applicable Motors	When Enabled	Classification	Reference
Pn585	2	Program Jogging Movement Speed	1 to 10,000	1 mm/s	50	Linear	Immediately	Setup	↪ Chap. 8.7.2 'Program Jogging' ...page 264

Parameter No.	Size	Name	Setting Range	Setting Unit	Default Setting	Applicable Motors	When Enabled	Classification	Reference
Pn586	2	Motor Running Cooling Ratio	0 to 100	1%/ Max. speed	0	Linear	Immediately	Setup	–

Parameter No.	Size	Name	Setting Range	Setting Unit	Default Setting	Applicable Motors	When Enabled	Classification	Reference
Pn587	2	Polarity Detection Execution Selection for Absolute Linear Encoder	0000h to 0001h	–	0000h	Linear	Immediately	Setup	–

n.□□□X	Polarity Detection Selection for Absolute Linear Encoder	Reference
0	Do not detect polarity.	↪ Chap. 6.10.1 'Polarity Detection' ...page 152
1	Detect polarity.	

Parameter No.	Size	Name	Setting Range	Setting Unit	Default Setting	Applicable Motors	When Enabled	Classification	Reference
Pn600*6	2	Regenerative Resistor Capacity*2	Depends on model.*3	10 W	0	All	Immediately	Setup	↪ Chap. 6.18 'Setting the Regenerative Resistor Capacity' ...page 187

Parameter No.	Size	Name	Setting Range	Setting Unit	Default Setting	Applicable Motors	When Enabled	Classification	Reference
Pn601	2	Dynamic Brake Resistor Allowable Energy Consumption	0 to 65,535	10 J	0	All	After restart	Setup	*6

Parameter No.	Size	Name	Setting Range	Setting Unit	Default Setting	Applicable Motors	When Enabled	Classification	Reference
Pn603	2	Regenerative Resistance	0 to 65,535	10 mΩ	0	All	Immediately	Setup	↪ Chap. 6.18 'Setting the Regenerative Resistor Capacity' ...page 187

Parameter No.	Size	Name	Setting Range	Setting Unit	Default Setting	Applicable Motors	When Enabled	Classification	Reference
Pn604*7	2	Dynamic Brake Resistance	0 to 65,535	10 mΩ	0	All	After restart	Setup	*6

Parameter No.	Size	Name	Setting Range	Setting Unit	Default Setting	Applicable Motors	When Enabled	Classification	Reference
Pn61A	2	Overheat Protection Selections	0000h to 0003h	–	0000h	All	After restart	Setup	↪ Chap. 7.15.1 'Overheat Protection' ...page 248

n.□□□X	Overheat Protection Selections	
0	Disable overheat protection.	
1	Use overheat protection in the YASKAWA Linear Servomotor.*7	

n.□□□X	Overheat Protection Selections	
2	Monitor a negative voltage input from a sensor attached to the machine and use overheat protection.	
3	Monitor a positive voltage input from a sensor attached to the machine and use overheat protection.	

Parameter No.	Size	Name	Setting Range	Setting Unit	Default Setting	Applicable Motors	When Enabled	Classification	Reference
Pn61B ^{*9}	2	Overheat Alarm Level	0 to 500	0.01 V	250	All	Immediately	Setup	↔ Chap. 7.15.3 'Overheat Protection Selections' ...page 249

Parameter No.	Size	Name	Setting Range	Setting Unit	Default Setting	Applicable Motors	When Enabled	Classification	Reference
Pn61C ^{*9}	2	Overheat Warning Level	0 to 100	1%	100	All	Immediately	Setup	↔ Chap. 7.15.3 'Overheat Protection Selections' ...page 249

Parameter No.	Size	Name	Setting Range	Setting Unit	Default Setting	Applicable Motors	When Enabled	Classification	Reference
Pn61D ^{*9}	2	Overheat Alarm Filter Time	0 to 65,535	1 s	0	All	Immediately	Setup	↔ Chap. 7.15.3 'Overheat Protection Selections' ...page 249


Parameter No.	Size	Name	Setting Range	Setting Unit	Default Setting	Applicable Motors	When Enabled	Classification	Reference
Pn621 to Pn628 ^{*4}	–	Safety Module-Related Parameters	–	–	–	All	–	–	–

*1. Set a percentage of the motor rated torque.

*2. Normally set this parameter to 0. If you use an External Regenerative Resistor, set the capacity (W) of the External Regenerative Resistor.


*3. The upper limit is the maximum output capacity (W) of the SERVOPACK.

*4. These parameters are for SERVOPACKs with a Safety Module. Refer to the following manual for details.

 Σ -V-Series/ Σ -V-Series for Large-Capacity Models/ Σ -7-Series User's Manual Safety Module (Manual No.: SIEP C720829 06)

*5. With PROFINET, this is automatically set during initialization when the power supply is turned ON.

*6. These parameters are for SERVOPACKs that support the dynamic brake hardware option specifications. Refer to the following manual for details.

 Σ -7-Series AC Servo Drive Σ -7S/ Σ -7W SERVOPACK with Dynamic Brake Hardware Option Specifications Product Manual (Manual No.: SIEP S800001 73)

*7. The SGLFW2 is the only YASKAWA Linear Servomotor that supports this function.

*8. Enabled only when Pn61A is set to n.□□□2 or n.□□□3.

17.3 Object List

- VOR = Valid On Reset
- Access:
 - RO = Read Only
 - RW = Read and Write
- PZDO mapping:
 - No = Cannot be mapped
 - RPZD = May be mapped into PNU 915 and PNU 916
 - TPZD = May be mapped into PNU 916 only

PNU (dec)	Sub-index	Name	Data Type	Access	PDO Mapping	Saving to EEPROM *1	Default Value	Lower Limit	Upper Limit	Parameter No. *2
915		DO IO Data Configuring (Setpoint Telegram)								
	0	Setpoint PZD 1	UINT	RW	No	Yes	6040h	0	FFFFh	C00
	1	Setpoint PZD 2					2505h			C01
	2	Setpoint PZD 3					0			C02
	3	Setpoint PZD 4					0			C03
	4	Setpoint PZD 5					0			C04
	5	Setpoint PZD 6					0			C05
	6	Setpoint PZD 7					0			C06
	7	Setpoint PZD 8					0			C07
	8	Setpoint PZD 9					0			C08
	9	Setpoint PZD 10					0			C09
	10	Setpoint PZD 11					0			C0A
	11	Setpoint PZD 12					0			C0B
	12	Setpoint PZD 13					0			C0C
	13	Setpoint PZD 14					0			C0D
	14	Setpoint PZD 15					0			C0E
	15	Setpoint PZD 16					0			C0F

Object List

PNU (dec)	Sub-index	Name	Data Type	Access	PDO Mapping	Saving to EEPROM *1	Default Value	Lower Limit	Upper Limit	Parameter No. *2
916		DO IO Data Configuring (Actual Value Telegram)								
	0	Actual value PZD 1	UINT	RW	No	Yes	6041h	0	FFFFh	C10
	1	Actual value PZD 2					2506h			C11
	2	Actual value PZD 3					0			C12
	3	Actual value PZD 4					0			C13
	4	Actual value PZD 5					0			C14
	5	Actual value PZD 6					0			C15
	6	Actual value PZD 7					0			C16
	7	Actual value PZD 8					0			C17
	8	Actual value PZD 9					0			C18
	9	Actual value PZD 10					0			C19
	10	Actual value PZD 11					0			C1A
	11	Actual value PZD 12					0			C1B
	12	Actual value PZD 13					0			C1C
	13	Actual value PZD 14					0			C1D
	14	Actual value PZD 15					0			C1E
	15	Actual value PZD 16					0			C1F
PNU (dec)	Sub-index	Name	Data Type	Access	PDO Mapping	Saving to EEPROM *1	Default Value	Lower Limit	Upper Limit	Parameter No. *2
922	0	Telegram selection	UINT	RW	No	Yes	1	0	999	C20

PNU (dec)	Subindex	Name	Data Type	Access	PDO Mapping	Saving to EEPROM *1	Default Value
923		List of all Parameters for Signals					
	0	Empty					0
	1	Controlword 1 (STW1)					6040h
	2	Statusword 1 (ZSW1)					6041h
	3	Controlword 2 (STW2)					2503h
	4	Statusword 2 (ZSW2)					2504h
	5	Speed Setpoint A (NSOLL_A)					2505h
	6	Speed Actual Value A (NIST_A)					2506h
	7	Speed Setpoint B (NSOLL_B)					2507h
	8	Speed Actual Value B (NIST_B)					2508h
	9 to 20	Reserved					0
	21	Input (digital) (E_DIGITAL)					2521h
	22	Output (digital) (A_DIGITAL)					2522h
	23 to 27	Reserved					0
	28	Position Actual Value A (XIST_A)					6064h
	29 to 31	Reserved					0
	32	Traversing Block Selection (SATZANW)					2532h
	33	Actual Traversing Block (AKTSATZ)					2533h
	34	Target Position (MDI_TARPOS)	UINT	RO	No	No	607Ah
	35	Profile Velocity (MDI_VELOCITY)					6081h
	36	MDI Acceleration (MDI_ACC)					2536h
	37	MDI Deceleration (MDI_DEC)					2537h
	38	MDI Mode (MDI_MOD)					2538h
	39 to 99	Reserved					0
	100	Modes of Operation					6060h
	101	Modes of Operation Display					6061h
	102	Position Demand Value					6062h
	103	Position Actual Internal Value					6063h
	104	Velocity Demand Value					606Bh
	105	Velocity Actual Value					606Ch
	106	Target Torque					6071h
	107	Torque Demand					6074h
	108	Torque Actual Value					6077h
109	Profile Acceleration					6083h	
110	Profile Deceleration					6084h	
111	Torque Slope					6087h	

Object List

PNU (dec)	Subindex	Name	Data Type	Access	PDO Mapping	Saving to EEPROM *1	Default Value
	112	Touch Probe Function					60B8h
	113	Touch Probe Status					60B9h
	114	Touch Probe 1 Position Value					60BAh
	115	Touch Probe 2 Position Value					60BCh
	116	Following Error Actual Value					60F4h
	117	Position Demand Internal Value					60FCh
	118	Target Velocity					60FFh
	119	Target Position in Range					2401h
	120	Actual Position in Range					2402h

PNU (dec)	Sub-index	Name	Data Type	Access	PDO Mapping	Saving to EEPROM *1	Default Value	Lower Limit	Upper Limit	Parameter No. *2
925	0	Sign-Of-Life Failures	UINT	RW	No	Yes	1	0	65535	C21

PNU (dec)	Subindex	Name	Data Type	Access	PDO Mapping	Saving to EEPROM *1	Default Value
930	0	PROFIdrive Operating Mode	UINT	RO	No	No	8000h

PNU (dec)	Subindex	Name	Data Type	Access	PDO Mapping	Saving to EEPROM *1	Default Value
944	0	Fault Message Counter	UINT	RO	No	No	0

PNU (dec)	Subindex	Name	Data Type	Access	PDO Mapping	Saving to EEPROM *1	Default Value
947		Fault Number					
	0 to 7	Actual fault situation n					
	8 to 15	Fault situation (n-1)					
	16 to 23	Fault situation (n-2)					
	24 to 31	Fault situation (n-3)					
	32 to 39	Fault situation (n-4)	UINT	RO	No	No	0
	40 to 47	Fault situation (n-5)					
	48 to 55	Fault situation (n-6)					
	56 to 63	Fault situation (n-7)					

PNU (dec)	Subindex	Name	Data Type	Access	PDO Mapping	Saving to EEPROM *1	Default Value	Lower Limit	Upper Limit
952		Fault Situation Counter	UINT	RW	No	No	0	-	-

PNU (dec)	Subindex	Name	Data Type	Access	PDO Mapping	Saving to EEPROM *1	Default Value
964		Drive Unit Identification					
	0	Manufacturer	UINT	RO	No	No	0111h
	1	Drive unit type					0250h
	2	Version (software)					-
	3	Firmware date (year)					-
	4	Firmware date (day/month)					-
	5	Number of drive objects (DO)					0001h

PNU (dec)	Subindex	Name	Data Type	Access	PDO Mapping	Saving to EEPROM *1	Default Value
965		Profile Identification Number					
	0	Profile number	OS[1]	RO	No	No	03h
	1	Profile version	OS[1]				29h

PNU (dec)	Subindex	Name	Data Type	Access	PDO Mapping	Saving to EEPROM *1	Default Value	Lower Limit	Upper Limit
972		Drive Reset	UINT	RW	No	No	0	0	1

PNU (dec)	Subindex	Name	Data Type	Access	PDO Mapping	Saving to EEPROM *1	Default Value
974		Base Mode Parameter Access Service Identification					
	0	Max. block length	UINT	RO	No	No	240
	1	Max. number of parameter requests per multi-parameter request					39
	2	Max. latency per request					0

PNU (dec)	Subindex	Name	Data Type	Access	PDO Mapping	Saving to EEPROM *1	Default Value
975		DO Identification					
	0	Manufacturer	UINT	RO	No	No	0111h
	1	DO type					0000h
	2	Version (software)					-
	3	Firmware date (year)					-
	4	Firmware date (day/month)					-
	5	PROFIdrive DO type class (structure)					0001h
	6	PROFIdrive DO sub class 1					0015h
	7	Drive object ID (DO-ID)					0001h

Object List

PNU (dec)	Sub-index	Name	Data Type	Access	PDO Mapping	Saving to EEPROM *1	Default Value	Lower Limit	Upper Limit	Parameter No. *2
976	0	Load Device Parameter Set	UINT	RW	No	No	0	0	1	C22

PNU (dec)	Sub-index	Name	Data Type	Access	PDO Mapping	Saving to EEPROM *1	Default Value	Lower Limit	Upper Limit	Parameter No. *2
977	0	Transfer in Non-volatile Memory (global)	UINT	RW	No	No	0	0	1	C23

PNU (dec)	Sub-index	Name	Data Type	Access	PDO Mapping	Saving to EEPROM *1	Default Value
980 to 989		Number List of Defined Parameter	UINT	RO	No	No	-

Index (hex)	Sub-index	Name	Data Type	Access	PDO Mapping	Saving to EEPROM *1	Default Value	Lower Limit	Upper Limit
2100h	0	Get Parameter - Parameter Identify	UINT	RW	No	No	FFFFh	0	FFFFh

Index (hex)	Sub-index	Name	Data Type	Access	PDO Mapping	Saving to EEPROM *1	Default Value
2101h	0	Get Parameter - Parameter Value	DINT	RO	No	No	0

Index (hex)	Sub-index	Name	Data Type	Access	PDO Mapping	Saving to EEPROM *1	Default Value	Lower Limit	Upper Limit
2102h	0	Set Parameter - Parameter Identify	UINT	RW	No	No	FFFFh	0	FFFFh

Index (hex)	Sub-index	Name	Data Type	Access	PDO Mapping	Saving to EEPROM *1	Default Value	Lower Limit	Upper Limit
2103h	0	Set Parameter - Parameter Value	DINT	RW	No	No	0	8000 0000h	7FFF FFFFh

Index (hex)	Sub-index	Name	Data Type	Access	PDO Mapping	Saving to EEPROM *1	Default Value	Lower Limit	Upper Limit	Parameter No. *2
2300h	-	User Parameter Configuration	UDINT	RW	No	Yes	1	0	1	B00

Index (hex)	Sub-index	Name	Data Type	Access	PDO Mapping	Saving to EEPROM *1	Default Value	Lower Limit	Upper Limit	Parameter No. *2
2301h		Position User Unit								
	0	Numerator	UDINT	RW	No	Yes	1	1	7FFF FFFFh	B02
	1	Denominator	UDINT	RW	No	Yes	1	1	7FFF FFFFh	B04

Index (hex)	Sub-index	Name	Data Type	Access	PDO Mapping	Saving to EEPROM *1	Default Value	Lower Limit	Upper Limit	Parameter No. *2
2302h		Velocity User Unit								
	0	Numerator	UDINT	RW	No	Yes	1	1	7FFF FFFFh	B06
	1	Denominator	UDINT	RW	No	Yes	1	1	7FFF FFFFh	B08

Index (hex)	Sub-index	Name	Data Type	Access	PDO Mapping	Saving to EEPROM *1	Default Value	Lower Limit	Upper Limit	Parameter No. *2
2303h		Acceleration User Unit								
	0	Numerator	UDINT	RW	No	Yes	1	1	7FFF FFFFh	B0A
	1	Denominator	UDINT	RW	No	Yes	1	1	7FFF FFFFh	B0C

Index (hex)	Sub-index	Name	Data Type	Access	PDO Mapping	Saving to EEPROM *1	Default Value	Lower Limit	Upper Limit	Parameter No. *2
2400h	0	Position Range Limit Designation	UINT	RW	No	Yes	0	0	3	BA0

Index (hex)	Sub-index	Name	Data Type	Access	PDO Mapping	Saving to EEPROM *1	Default Value	Unit	Parameter No. *2
2401h	0	Target Position in Range	DINT	RO	TPZD	No	-	Pos. unit	BA2

Index (hex)	Sub-index	Name	Data Type	Access	PDO Mapping	Saving to EEPROM *1	Default Value	Unit	Parameter No. *2
2402h	0	Actual Position in Range	DINT	RO	TPZD	No	-	Pos. unit	BA4

Index (hex)	Sub-index	Name	Data Type	Access	PDO Mapping	Saving to EEPROM *1	Default Value	Lower Limit	Upper Limit	Parameter No. *2
2503h	0	Controlword 2 (STW2)	UINT	RW	RPZD	No	0	0	FFFFh	BB0

Object List

Index (hex)	Sub-index	Name	Data Type	Access	PDO Mapping	Saving to EEPROM *1	Default Value	Lower Limit	Upper Limit	Unit	Parameter No. *2
2504h	0	Statusword 2 (ZSW2)	UINT	RO	TPZD	No	0				BB1
Index (hex)	Sub-index	Name	Data Type	Access	PDO Mapping	Saving to EEPROM *1	Default Value	Lower Limit	Upper Limit	Unit	Parameter No. *2
2505h	0	Speed Set-point A (NSOLL_A)	INT	RW	RPZD	No	0	8000h	7FFFh	N2 Vel. unit	BB2
Index (hex)	Sub-index	Name	Data Type	Access	PDO Mapping	Saving to EEPROM *1	Default Value	Lower Limit	Upper Limit	Unit	Parameter No. *2
2506h	0	Speed Actual Value A (NIST_A)	INT	RO	TPZD	No	-			N2 Vel. unit	BB3
Index (hex)	Sub-index	Name	Data Type	Access	PDO Mapping	Saving to EEPROM *1	Default Value	Lower Limit	Upper Limit	Unit	Parameter No. *2
2507h	0	Speed Set-point B (NSOLL_B)	DINT	RW	RPZD	No	0	8000 0000h	7FFF FFFFh	N4 Vel. unit	BB4
Index (hex)	Sub-index	Name	Data Type	Access	PDO Mapping	Saving to EEPROM *1	Default Value	Lower Limit	Upper Limit	Unit	Parameter No. *2
2508h	0	Speed Actual Value B (NIST_B)	DINT	RO	TPZD	No	-			N4 Vel. unit	BB6
Index (hex)	Sub-index	Name	Data Type	Access	PDO Mapping	Saving to EEPROM *1	Default Value	Lower Limit	Upper Limit	Unit	Parameter No. *2
2521h	0	Digital Inputs (E_DIGITAL)	UINT	RO	TPZD	No	-				BC0
Index (hex)	Sub-index	Name	Data Type	Access	PDO Mapping	Saving to EEPROM *1	Default Value	Lower Limit	Upper Limit	Unit	Parameter No. *2
2522h	0	Digital Outputs (A_DIGITAL)	UINT	RW	RPZD	No	0	0	FFFFh		BC1
Index (hex)	Sub-index	Name	Data Type	Access	PDO Mapping	Saving to EEPROM *1	Default Value	Lower Limit	Upper Limit	Unit	Parameter No. *2
2532h	0	Traversing Block Selection (SATZANW)	UINT	RW	RPZD	No	0	0	65535		BD0
Index (hex)	Sub-index	Name	Data Type	Access	PDO Mapping	Saving to EEPROM *1	Default Value	Lower Limit	Upper Limit	Unit	Parameter No. *2
2533h	0	Actual Traversing Block (AKTSATZ)	UINT	RO	TPZD	No	0				BD1

Index (hex)	Sub-index	Name	Data Type	Access	PDO Mapping	Saving to EEPROM *1	Default Value	Lower Limit	Upper Limit	Unit	Parameter No. *2
2536h	0	MDI Acceleration (MDI_ACC)	UINT	RW	RPZD	No	0	0	65535	Max. Acc. / FFFFh	BD2

Index (hex)	Sub-index	Name	Data Type	Access	PDO Mapping	Saving to EEPROM *1	Default Value	Lower Limit	Upper Limit	Unit	Parameter No. *2
2537h	0	MDI Deceleration (MDI_DEC)	UINT	RW	RPZD	No	0	0	65535	Max. Dec. / FFFFh	BD3

Index (hex)	Sub-index	Name	Data Type	Access	PDO Mapping	Saving to EEPROM *1	Default Value	Lower Limit	Upper Limit	Unit	Parameter No. *2
2538h	0	MDI Mode (MDI_MOD)	UINT	RW	RPZD	No	0	0	FFFFh		BD4

Index (hex)	Sub-index	Name	Data Type	Access	PDO Mapping	Saving to EEPROM *1	Default Value	Lower Limit	Upper Limit	Unit	Parameter No. *2
2610h		Actual Traversing Block (AKTSATZ)									
	0 to 63	Task mode value	UDINT	RW	No	Yes	0	0	FFFF FFFFh		8200 to 827E

Index (hex)	Sub-index	Name	Data Type	Access	PDO Mapping	Saving to EEPROM *1	Default Value	Lower Limit	Upper Limit	Unit	Parameter No. *2
2611h		Traversing Block Target Position									
	0 to 63	Target position value	DINT	RW	No	Yes	0	8000 0000h	7FFF FFFFh	Pos. unit	8280 to 82FE

Index (hex)	Sub-index	Name	Data Type	Access	PDO Mapping	Saving to EEPROM *1	Default Value	Lower Limit	Upper Limit	Unit	Parameter No. *2
2612h		Traversing Block Profile Velocity									
	0 to 63	Profile velocity value	UDINT	RW	No	Yes	0	0	7FFF FFFFh	Vel. unit	8300 to 837E

Index (hex)	Sub-index	Name	Data Type	Access	PDO Mapping	Saving to EEPROM *1	Default Value	Lower Limit	Upper Limit	Unit	Parameter No. *2
2613h		Traversing Block Profile Acceleration									
	0 to 63	Profile acceleration value	UDINT	RW	No	Yes	0	0	7FFF FFFFh	Acc. unit	8380 to 83FE

Object List

Index (hex)	Sub-index	Name	Data Type	Access	PDO Mapping	Saving to EEPROM *1	Default Value	Lower Limit	Upper Limit	Unit	Parameter No. *2
2614h		Traversing Block Profile Deceleration									
	0 to 63	Profile deceleration value	UDINT	RW	No	Yes	0	0	7FFF FFFFh	Acc. unit	8400 to 847E
Index (hex)	Sub-index	Name	Data Type	Access	PDO Mapping	Saving to EEPROM *1	Default Value	Lower Limit	Upper Limit	Unit	Parameter No. *2
603Fh	0	Error Code	UINT	RO	RPZD	No	-	-	-	-	B10
Index (hex)	Sub-index	Name	Data Type	Access	PDO Mapping	Saving to EEPROM *1	Default Value	Lower Limit	Upper Limit	Unit	Parameter No. *2
6040h	0	Controlword (STW1)	UINT	RW	RPZD	No	0	0	FFFFh	-	B11
Index (hex)	Sub-index	Name	Data Type	Access	PDO Mapping	Saving to EEPROM *1	Default Value	Lower Limit	Upper Limit	Unit	Parameter No. *2
6041h	0	Statusword (ZSW1)	UINT	RO	TPZD	No	0	0	-	-	B12
Index (hex)	Sub-index	Name	Data Type	Access	PDO Mapping	Saving to EEPROM *1	Default Value	Lower Limit	Upper Limit	Unit	Parameter No. *2
605Ah	0	Quick Stop Option Code	INT	RW	No	Yes	2	0	3	-	B13
Index (hex)	Sub-index	Name	Data Type	Access	PDO Mapping	Saving to EEPROM *1	Default Value	Lower Limit	Upper Limit	Unit	Parameter No. *2
605Dh	0	Halt Option Code	INT	RW	No	Yes	3	1	3	-	B16
Index (hex)	Sub-index	Name	Data Type	Access	PDO Mapping	Saving to EEPROM *1	Default Value	Lower Limit	Upper Limit	Unit	Parameter No. *2
605Eh	0	Fault Reaction Option Code	INT	RW	No	Yes	2	0	3	-	B17
Index (hex)	Sub-index	Name	Data Type	Access	PDO Mapping	Saving to EEPROM *1	Default Value	Lower Limit	Upper Limit	Unit	Parameter No. *2
6060h	0	Modes of Operation	INT	RW	RPZD	Yes	0	-3	7	-	B18
Index (hex)	Sub-index	Name	Data Type	Access	PDO Mapping	Saving to EEPROM *1	Default Value	Lower Limit	Upper Limit	Unit	Parameter No. *2
6061h	0	Modes of Operation Display	INT	RO	TPZD	No	0	0	-	-	B19

Index (hex)	Sub-index	Name	Data Type	Access	PDO Mapping	Saving to EEPROM *1	Default Value	Unit	Parameter No. *2		
6062h	0	Position Demand Value	DINT	RO	TPZD	No	-	Pos. unit	B20		
Index (hex)	Sub-index	Name	Data Type	Access	PDO Mapping	Saving to EEPROM *1	Default Value	Unit	Parameter No. *2		
6063h	0	Position Actual Internal Value	DINT	RO	TPZD	No	-	Increment	B22		
Index (hex)	Sub-index	Name	Data Type	Access	PDO Mapping	Saving to EEPROM *1	Default Value	Unit	Parameter No. *2		
6064h	0	Position Actual Value (XIST_A)	DINT	RO	TPZD	No	-	Pos. unit	B24		
Index (hex)	Sub-index	Name	Data Type	Access	PDO Mapping	Saving to EEPROM *1	Default Value	Lower Limit	Upper Limit	Unit	Parameter No. *2
6065h	0	Following Error Window	UDINT	RW	No	Yes	20h	0	7FFF FFFFh	Pos. unit	B26
Index (hex)	Sub-index	Name	Data Type	Access	PDO Mapping	Saving to EEPROM *1	Default Value	Lower Limit	Upper Limit	Unit	Parameter No. *2
6066h	0	Following Error Time Out	UINT	RW	No	Yes	0	0	FFFFh	ms	B28
Index (hex)	Sub-index	Name	Data Type	Access	PDO Mapping	Saving to EEPROM *1	Default Value	Lower Limit	Upper Limit	Unit	Parameter No. *2
6067h	0	Position Window	UDINT	RW	No	Yes	20h	0	7FFF FFFFh	Pos. unit	B2A
Index (hex)	Sub-index	Name	Data Type	Access	PDO Mapping	Saving to EEPROM *1	Default Value	Lower Limit	Upper Limit	Unit	Parameter No. *2
6068h	0	Position Window Time	UINT	RW	No	Yes	0	0	FFFFh	ms	B2C
Index (hex)	Sub-index	Name	Data Type	Access	PDO Mapping	Saving to EEPROM *1	Default Value	Unit	Parameter No. *2		
606Bh	0	Velocity Demand Value	DINT	RO	TPZD	No	-	Pos. unit	B2E		

Object List

Index (hex)	Sub-index	Name	Data Type	Access	PDO Mapping	Saving to EEPROM *1	Default Value	Unit	Parameter No. *2		
606Ch	0	Velocity Actual Value	DINT	RO	TPZD	No	-	Pos. unit	B30		
Index (hex)	Sub-index	Name	Data Type	Access	PDO Mapping	Saving to EEPROM *1	Default Value	Lower Limit	Upper Limit	Unit	Parameter No. *2
606Dh	0	Velocity Window	UINT	RW	No	No	0	0	FFFFh	Vel. unit	B32
Index (hex)	Sub-index	Name	Data Type	Access	PDO Mapping	Saving to EEPROM *1	Default Value	Lower Limit	Upper Limit	Unit	Parameter No. *2
606Eh	0	Velocity Window Time	UINT	RW	No	Yes	0	0	FFFFh	ms	B34
Index (hex)	Sub-index	Name	Data Type	Access	PDO Mapping	Saving to EEPROM *1	Default Value	Lower Limit	Upper Limit	Unit	Parameter No. *2
606Fh	0	Velocity Threshold	UINT	RW	No	Yes	0	0	FFFFh	Vel. unit	B35
Index (hex)	Sub-index	Name	Data Type	Access	PDO Mapping	Saving to EEPROM *1	Default Value	Lower Limit	Upper Limit	Unit	Parameter No. *2
6071h	0	Target Torque	INT	RW	RPZD	No	0	8000h	7FFFh	0.1% *3	B36
Index (hex)	Sub-index	Name	Data Type	Access	PDO Mapping	Saving to EEPROM *1	Default Value	Lower Limit	Upper Limit	Unit	Parameter No. *2
6072h	0	Max. Torque	UINT	RW	No	Yes	Max. Motor Torque (Pn BF4)	0	Max. Motor Torque (Pn BF4)	0.1% *3	B38
Index (hex)	Sub-index	Name	Data Type	Access	PDO Mapping	Saving to EEPROM *1	Default Value	Unit	Parameter No. *2		
6074h	0	Torque Demand Value	INT	RO	TPZD	No	0	0.1% *3	B3A		
Index (hex)	Sub-index	Name	Data Type	Access	PDO Mapping	Saving to EEPROM *1	Default Value	Unit	Parameter No. *2		
6077h	0	Torque Actual Value	INT	RO	TPZD	No	0	0.1% *3	B3E		

Index (hex)	Sub-index	Name	Data Type	Access	PDO Mapping	Saving to EEPROM *1	Default Value	Lower Limit	Upper Limit	Unit	Parameter No. *2
607Ah	0	Target Position (MDI_TAR POS)	DINT	RW	RPZD	No	0	8000 0000h	7FFF FFFFh	Pos. unit	B40
607Bh		Position Range Limit									
	0	Min. position range limit	DINT	RW	No	Yes	8000 0000h	8000 0000h	0	Pos. unit	B42
	1	Max. position range limit	DINT	RW	No	Yes	7FFF FFFFh	0	7FFF FFFFh	Pos. unit	B44
607Ch	0	Home Offset	DINT	RW	No	Yes	0	8000 0000h	7FFF FFFFh	Pos. unit	B46
607Dh		Software Position Limit									
	0	Min. position limit	DINT	RW	No	Yes	8000 0000h	8000 0000h	7FFF FFFFh	Pos. unit	B48
	1	Max. position limit	DINT	RW	No	Yes	7FFF FFFFh	8000 0000h	7FFF FFFFh	Pos. unit	B4A
607Fh	0	Max. Profile Velocity	UDINT	RW	No	Yes	Max. Motor Speed (Pn BF0)	0	Max. Motor Speed (Pn BF0)	Vel. unit	B4C
6081h	0	Profile Velocity (MDI_VEL OCITY)	UDINT	RW	RPZD	Yes	0	0	Max. Profile Velocity (Pn B4C)	Vel. unit	B4E

Object List

Index (hex)	Sub-index	Name	Data Type	Access	PDO Mapping	Saving to EEPROM *1	Default Value	Lower Limit	Upper Limit	Unit	Parameter No. *2
6083h	0	Profile Acceleration	UDINT	RW	RPZD	Yes	0	0	Max. Acceleration (Pn B7C)	Acc. unit	B50
6084h	0	Profile Deceleration	UDINT	RW	RPZD	Yes	0	0	Max. Deceleration (Pn B7E)	Acc. unit	B52
6085h	0	Quick Stop Deceleration	UDINT	RW	No	Yes	Max. Motor Acc. (Pn BF2)	0	Max. Deceleration (Pn B7E)	Acc. unit	B54
6087h	0	Torque Slope	UDINT	RW	RPZD	Yes	0	0	7FFF FFFFh	0.1%/s *3	B56
6098h	0	Homing Method	INT	RW	No	Yes	0	0	35		B58
6099h		Homing Speeds									
	0	Speed during search for switch	DINT	RW	No	Yes	0	0	Max. Motor Speed (Pn BF0)	Vel. unit	B5A
	1	Speed during search for zero	DINT	RW	No	Yes	0	0	Max. Motor Speed (Pn BF0)	Vel. unit	B5C

Index (hex)	Sub-index	Name	Data Type	Access	PDO Mapping	Saving to EEPROM *1	Default Value	Lower Limit	Upper Limit	Unit	Parameter No. *2
609Ah	0	Homing Acceleration	DINT	RW	No	Yes	0	0	Max. Motor Acc. (Pn BF2)	Acc. unit	B5E

Index (hex)	Sub-index	Name	Data Type	Access	PDO Mapping	Saving to EEPROM *1	Default Value	Lower Limit	Upper Limit	Parameter No. *2
60B8h	0	Touch Probe Function	INT	RW	RPZD	No	0	0	FFFFh	B64

Index (hex)	Sub-index	Name	Data Type	Access	PDO Mapping	Saving to EEPROM *1	Default Value	Parameter No. *2
60B9h	0	Touch Probe Status	UINT	RO	TPZD	No	0	B66

Index (hex)	Sub-index	Name	Data Type	Access	PDO Mapping	Saving to EEPROM *1	Default Value	Unit	Parameter No. *2
60BAh	0	Touch Probe 1 Position Value	DINT	RO	TPZD	No	-	Pos. unit	B68

Index (hex)	Sub-index	Name	Data Type	Access	PDO Mapping	Saving to EEPROM *1	Default Value	Unit	Parameter No. *2
60BCh	0	Touch Probe 2 Position Value	DINT	RO	TPZD	No	-	Pos. unit	B6A

Index (hex)	Sub-index	Name	Data Type	Access	PDO Mapping	Saving to EEPROM *1	Default Value	Lower Limit	Upper Limit	Parameter No. *2
60C1h	0	Interpolation Set-point	DINT	RW	RPZD	No	0	-	-	B70

Index (hex)	Sub-index	Name	Data Type	Access	PDO Mapping	Saving to EEPROM *1	Default Value	Lower Limit	Upper Limit	Parameter No. *2	
60C2h		Interpolation Time Period									
	0	Interpolation time unit	INT	RW	No	Yes	1	-	-	B6E	
	1	Interpolation time index	INT	RW	No	Yes	-3	-	-	B6F	

Index (hex)	Sub-index	Name	Data Type	Access	PDO Mapping	Saving to EEPROM *1	Default Value	Lower Limit	Upper Limit	Unit	Parameter No. *2
60C5h	0	Max. Acceleration	DINT	RW	No	Yes	Max. Motor Acc. (Pn BF2)	0	Max. Motor Acc. (Pn BF2)	Acc. unit	B7C

Object List

Index (hex)	Sub-index	Name	Data Type	Access	PDO Mapping	Saving to EEPROM *1	Default Value	Lower Limit	Upper Limit	Unit	Parameter No. *2
60C6h	0	Max. Deceleration	DINT	RW	No	Yes	Max. Motor Acc. (Pn BF2)	0	Max. Motor Acc. (Pn BF2)	Acc. unit	B7E

Index (hex)	Sub-index	Name	Data Type	Access	PDO Mapping	Saving to EEPROM *1	Default Value	Lower Limit	Upper Limit	Unit	Parameter No. *2
60E0h	0	Positive Torque Limit Value	INT	RW	RPZD	Yes	Max. Motor Torque (Pn BF4)	0	Max. Motor Torque (Pn BF4)	0.1% *3	B80

Index (hex)	Sub-index	Name	Data Type	Access	PDO Mapping	Saving to EEPROM *1	Default Value	Lower Limit	Upper Limit	Unit	Parameter No. *2
60E1h	0	Negative Torque Limit Value	INT	RW	RPZD	Yes	Max. Motor Torque (Pn BF4)	0	Max. Motor Torque (Pn BF4)	0.1% *3	B82

Index (hex)	Sub-index	Name	Data Type	Access	PDO Mapping	Saving to EEPROM *1	Default Value	Unit	Parameter No. *2
60F4h	0	Following Error Actual Value	DINT	RO	TPZD	No	-	Pos. unit	B84

Index (hex)	Sub-index	Name	Data Type	Access	PDO Mapping	Saving to EEPROM *1	Default Value	Unit	Parameter No. *2
60FCh	0	Position Demand Internal Value	DINT	RO	TPZD	No	-	Increment	B86

Index (hex)	Sub-index	Name	Data Type	Access	PDO Mapping	Saving to EEPROM *1	Default Value	Lower Limit	Upper Limit	Unit	Parameter No. *2
60FFh	0	Target Velocity	DINT	RW	RPZD	No	0	- Max. Profile Velocity (-Pn B4C)	Max. Profile Velocity (Pn B4C)	Vel. unit	B8E

Index (dec)	Sub-index	Name	Data Type	Access	PDO Mapping	Saving to EEPROM *1	Default Value
61000	0 to 239	IP of Station	OS[240]	RO	No	(Yes)	-

Index (dec)	Sub-index	Name	Data Type	Access	PDO Mapping	Saving to EEPROM ^{*1}	Default Value
61001	0 to 3	Name of Station	OS[4]	RO	No	(Yes)	0.0.0.0

Index (dec)	Sub-index	Name	Data Type	Access	PDO Mapping	Saving to EEPROM ^{*1}	Default Value
61002	0 to 5	MAC of Station	OS[6]	RO	No	(Yes)	00-20-B5-00-00-01

Index (dec)	Sub-index	Name	Data Type	Access	PDO Mapping	Saving to EEPROM ^{*1}	Default Value
61003	0 to 3	Standard Gateway of Station	OS[4]	RO	No	(Yes)	0.0.0.0

Index (dec)	Sub-index	Name	Data Type	Access	PDO Mapping	Saving to EEPROM ^{*1}	Default Value
61004	0 to 3	Subnet Mask of Station	OS[4]	RO	No	(Yes)	0.0.0.0

Index (hex)	Sub-index	Name	Data Type	Access	PDO Mapping	Saving to EEPROM ^{*1}	Default Value	Unit	Parameter No. ^{*2}
2312h	0	Max. Motor Speed	UDINT	RO	No	No	-	Vel. unit	BF0

Index (hex)	Sub-index	Name	Data Type	Access	PDO Mapping	Saving to EEPROM ^{*1}	Default Value	Unit	Parameter No. ^{*2}
2313h	0	Max. Motor Acceleration	UDINT	RO	No	No	-	Acc. unit	BF2

Index (hex)	Sub-index	Name	Data Type	Access	PDO Mapping	Saving to EEPROM ^{*1}	Default Value	Unit	Parameter No. ^{*2}
2314h	0	Max. Motor Torque	UINT	RO	No	No	-	0.1% ^{*3}	BF4

^{*1} Write "Save" to object 1010h to save all current parameter data as a batch in the EEPROM. If the objects are modified by the Digital Operator or SigmaWin+, the data will be directly stored in the EEPROM.

^{*2} The parameter numbers given in the table are the parameter numbers that are used with the Digital Operator and SigmaWin+.

^{*3} The rated motor torque is 100%.

17.4 PROFINET Parameter Request Error Codes

The following table shows the PROFIdrive parameter request error codes.

Error	Meaning	Used at
00h	Impermissible parameter number	Access to unavailable parameter
01h	Parameter value cannot be changed	Change access to a parameter value that cannot be changed

PROFINET Parameter Request Error Codes

Error	Meaning	Used at
02h	Low or high limit exceeded	Change access with value outside the limits
03h	Invalid subindex	Access to unavailable subindex
04h	No array	Access with subindex to non-indexed parameter
05h	Incorrect data type	Change access with value that does not match the data type of the parameter
06h	Setting not permitted (can only be reset)	Change access with value unequal to 0 when this is not permitted
07h	Description element cannot be changed	Change access to a description element that cannot be changed
09h	No description data available	Access to unavailable description (parameter value is available)
0Bh	No operation priority	Change access rights without rights to change parameters
0Fh	No text array available	Access to text array that is not available (parameter value is available)
11h	Request cannot be executed because of operating mode	<p>Access is temporarily not possible for reasons that are not specified in detail Error cause:</p> <ul style="list-style-type: none"> ■ Attempt to implement mapping when the mapping is not enabled. ■ Wrong Machine state for setting User Unit Setting Enable (2300h). It is only allowed in state S1: Switching On Inhibited or S2: Ready For Switching On. ■ Attempt to set Software position limit in Machine state S4: Operation, S5: Switching Off (sub-states S51: Switching Off: ramp stop and S52: Switching Off: quick stop). ■ Attempt to set Position range limit in Machine state S4: Operation, S5: Switching Off (sub-states S51: Switching Off: ramp stop and S52: Switching Off: quick stop). ■ Attempt to set S3: Switched On or S4: Operation in case of main power is off ■ Attempt to set pole detection mode in the states except Servo Off. ■ Attempt to change operation mode from pole detection mode to other modes before pole detection completion. ■ Attempt to store parameters (PNU 977 = 1) when User Unit Setting Enable (2300h) is enabled (2300h = 0). ■ Attempt to store parameters (PNU 977 = 1) or Load (restore) parameter (PNU 976 = 1) when the Machine state is different from S1: Switching On Inhibited or S2: Ready For Switching On. ■ Attempt to change PNU 922 when the Machine state is different from S1: Switching On Inhibited or S2: Ready For Switching On. ■ Attempt to change operation mode to pole detection mode in Servo On states

Error	Meaning	Used at
14h	Value impermissible	<p>Change access with a value that is within limits but is not permissible for other long- term reasons (parameter with defined single values)</p> <p>Error cause:</p> <ul style="list-style-type: none"> ■ The command in the controlword is not allowed. ■ Attempt to write not supported mode to Mode of Operation (6060h). ■ The commanded Homing Method (6098h) is not supported. ■ PZD communication parameter wrong setting. ■ In the objects Get Parameter - Parameter Identify (2100h) and Set Parameter - Parameter Identify (2102h) attempts to read/write value from/to not existing parameter number. ■ User Unit Setting Enable (2300h) - If after attempting to enable the user unit the Max motor Acceleration/Velocity in user unit is greater than 2^{31} or the Position user unit ratio is greater than 65536 or less than 1/4096. ■ Attempt to write value to any object from device profile in case of User Unit Setting Enable (2300h) bit 0 not equal to 1. ■ Absolute Target Torque is greater than Max. Torque (6072h). ■ Absolute Target Velocity is greater than Max. Profile Velocity (607Fh).
15h	Response too long	The length of the current response exceeds the maximum transmittable length
16h	Parameter address impermissible	Illegal value or value that is not supported for the attribute, number of elements, parameter number or sub-index, or a combination
17h	Illegal format	Write request: Illegal format or format of parameter data that is not supported
18h	Number of values inconsistent	Write request: Number of values of parameter data does not match number of elements at the parameter address
19h	DO non-existent	Request to DO, which does not exist
20h	Parameter text element cannot be changed	Change access to a parameter text element that cannot be changed
21h	Illegal Request ID	Service not supported
22h	Too much parameters requests	Permissible number of requested parameter is reached or actually exists
78h	PZD map failure	Parameter cannot be mapped to PZD (size mismatch or non-existent)
79h	PZD memory failure	Parameter cannot be mapped to PZD (out of memory)

17.5 Parameter Recording Table

Use the following table to record the settings of the parameters.

Parameter Recording Table

Parameter No.	Default Setting					Name	When Enabled
Pn000	0000h					Basic Function Selections 0	After restart
Pn001	0010h					Application Function Selections 1	After restart
Pn002	0001h					Application Function Selections 2	After restart
Pn006	0002h					Application Function Selections 6	Immediately
Pn007	0000h					Application Function Selections 7	Immediately
Pn008	4000h					Application Function Selections 8	After restart
Pn009	0010h					Application Function Selections 9	After restart
Pn00A	0001h					Application Function Selections A	After restart
Pn00B	0000h					Application Function Selections B	After restart
Pn00C	0000h					Application Function Selections C	After restart
Pn00D	0000h					Application Function Selections D	After restart
Pn00F	0000h					Application Function Selections F	After restart
Pn022	0000h					Application Function Selection 22	After restart
Pn080	0000h					Application Function Selections 80	After restart
Pn081	0000h					Application Function Selections 81	After restart
Pn100	400					Speed Loop Gain	Immediately
Pn101	2000					Speed Loop Integral Time Constant	Immediately
Pn102	400					Position Loop Gain	Immediately
Pn103	100					Moment of Inertia Ratio	Immediately
Pn104	400					Second Speed Loop Gain	Immediately
Pn105	2000					Second Speed Loop Integral Time Constant	Immediately
Pn106	400					Second Position Loop Gain	Immediately
Pn109	0					Feedforward	Immediately
Pn10A	0					Feedforward Filter Time Constant	Immediately
Pn10B	0000h					Gain Application Selections	*
Pn10C	200					Mode Switching Level for Torque Reference	Immediately
Pn10D	0					Mode Switching Level for Speed Reference	Immediately
Pn10E	0					Mode Switching Level for Acceleration	Immediately
Pn10F	0					Mode Switching Level for Position Deviation	Immediately
Pn11F	0					Position Integral Time Constant	Immediately
Pn121	100					Friction Compensation Gain	Immediately
Pn122	100					Second Friction Compensation Gain	Immediately
Pn123	0					Friction Compensation Coefficient	Immediately

Parameter Recording Table

Parameter No.	Default Setting					Name	When Enabled
Pn124	0					Friction Compensation Frequency Correction	Immediately
Pn125	100					Friction Compensation Gain Correction	Immediately
Pn131	0					Gain Switching Time 1	Immediately
Pn132	0					Gain Switching Time 2	Immediately
Pn135	0					Gain Switching Waiting Time 1	Immediately
Pn136	0					Gain Switching Waiting Time 2	Immediately
Pn139	0000h					Automatic Gain Switching Selections 1	Immediately
Pn13D	2000					Current Gain Level	Immediately
Pn140	0100h					Model Following Control- Related Selections	Immediately
Pn141	500					Model Following Control Gain	Immediately
Pn142	1000					Model Following Control Gain Correction	Immediately
Pn143	1000					Model Following Control Bias in the Forward Direction	Immediately
Pn144	1000					Model Following Control Bias in the Reverse Direction	Immediately
Pn145	500					Vibration Suppression 1 Frequency A	Immediately
Pn146	700					Vibration Suppression 1 Frequency B	Immediately
Pn147	1000					Model Following Control Speed Feedforward Compensation	Immediately
Pn148	500					Second Model Following Control Gain	Immediately
Pn149	1000					Second Model Following Gain Control Correction	Immediately
Pn14A	800					Vibration Suppression 2 Frequency	Immediately
Pn14B	100					Vibration Suppression 2 Correction	Immediately
Pn14F	0021h					Control-Related Selections	After restart
Pn160	0010h					Anti-Resonance Control- Related Selections	Immediately
Pn161	1000					Anti-Resonance Frequency	Immediately
Pn162	100					Anti-Resonance Gain Correction	Immediately
Pn163	0					Anti-Resonance Damping Gain	Immediately
Pn164	0					Anti-Resonance Filter Time Constant 1 Correction	Immediately
Pn165	0					Anti-Resonance Filter Time Constant 2 Correction	Immediately
Pn166	0					Anti-Resonance Damping Gain 2	Immediately

Parameter Recording Table

Parameter No.	Default Setting					Name	When Enabled
Pn170	1401h					Tuning-less Function- Related Selections	*
Pn181	0					Mode Switching Level for Speed Reference	Immediately
Pn182	0					Mode Switching Level for Acceleration	Immediately
Pn205	65535					Multiturn Limit	After restart
Pn207	0010h					Position Control Function Selections	After restart
Pn20A	32768					Number of External Scale Pitches	After restart
Pn20E	1					Electronic Gear Ratio (Numerator)	After restart
Pn210	1					Electronic Gear Ratio (Denominator)	After restart
Pn212	2048					Number of Encoder Output Pulses	After restart
Pn22A	0000h					Fully-closed Control Selections	After restart
Pn230	0000h					Position Control Expansion Function Selections	After restart
Pn231	0					Backlash Compensation	Immediately
Pn233	0					Backlash Compensation Time Constant	Immediately
Pn281	20					Encoder Output Resolution	After restart
Pn282	0					Linear Encoder Pitch	After restart
Pn304	500					Jogging Speed	Immediately
Pn305	0					Soft Start Acceleration Time	Immediately
Pn306	0					Soft Start Deceleration Time	Immediately
Pn308	0					Speed Feedback Filter Time Constant	Immediately
Pn30A	0					Deceleration Time for Servo OFF and Forced Stops	Immediately
Pn30C	0					Speed Feedforward Average Movement Time	Immediately
Pn310	0000h					Vibration Detection Selections	Immediately
Pn311	100					Vibration Detection Sensitivity	Immediately
Pn312	50					Vibration Detection Level	Immediately
Pn316	10000					Maximum Motor Speed	After restart
Pn324	300					Moment of Inertia Calculation Starting Level	Immediately
Pn383	50					Jogging Speed	Immediately
Pn384	10					Vibration Detection Level	Immediately
Pn385	50					Maximum Motor Speed	After restart
Pn401	100					First Stage First Torque Reference Filter Time Constant	Immediately

Parameter No.	Default Setting					Name	When Enabled
Pn402	800					Forward Torque Limit	Immediately
Pn403	800					Reverse Torque Limit	Immediately
Pn404	100					Forward External Torque Limit	Immediately
Pn405	100					Reverse External Torque Limit	Immediately
Pn406	800					Emergency Stop Torque	Immediately
Pn407	10000					Speed Limit during Torque Control	Immediately
Pn408	0000h					Torque-Related Function Selections	*
Pn409	5000					First Stage Notch Filter Frequency	Immediately
Pn40A	70					First Stage Notch Filter Q Value	Immediately
Pn40B	0					First Stage Notch Filter Depth	Immediately
Pn40C	5000					Second Stage Notch Filter Frequency	Immediately
Pn40D	70					Second Stage Notch Filter Q Value	Immediately
Pn40E	0					Second Stage Notch Filter Depth	Immediately
Pn40F	5000					Second Stage Second Torque Reference Filter Frequency	Immediately
Pn410	50					Second Stage Second Torque Reference Filter Q Value	Immediately
Pn412	100					First Stage Second Torque Reference Filter Time Constant	Immediately
Pn416	0000h					Torque-Related Function Selections 2	Immediately
Pn417	5000					Third Stage Notch Filter Frequency	Immediately
Pn418	70					Third Stage Notch Filter Q Value	Immediately
Pn419	0					Third Stage Notch Filter Depth	Immediately
Pn41A	5000					Fourth Stage Notch Filter Frequency	Immediately
Pn41B	70					Fourth Stage Notch Filter Q Value	Immediately
Pn41C	0					Fourth Stage Notch Filter Depth	Immediately
Pn41D	5000					Fifth Stage Notch Filter Frequency	Immediately
Pn41E	70					Fifth Stage Notch Filter Q Value	Immediately
Pn41F	0					Fifth Stage Notch Filter Depth	Immediately
Pn423	0000h					Speed Ripple Compensation Selections	*
Pn424	50					Torque Limit at Main Circuit Voltage Drop	Immediately
Pn425	100					Release Time for Torque Limit at Main Circuit Voltage Drop	Immediately
Pn426	0					Torque Feedforward Average Movement Time	Immediately

Parameter Recording Table

Parameter No.	Default Setting					Name	When Enabled
Pn427	0					Speed Ripple Compensation Enable Speed	Immediately
Pn456	15					Sweep Torque Reference Amplitude	Immediately
Pn460	0101h					Notch Filter Adjustment Selections 1	Immediately
Pn475	0000h					Gravity Compensation- Related Selections	After restart
Pn476	0					Gravity Compensation Torque	Immediately
Pn480	10000					Speed Limit during Force Control	Immediately
Pn481	400					Polarity Detection Speed Loop Gain	Immediately
Pn482	3000					Polarity Detection Speed Loop Integral Time Constant	Immediately
Pn483	30					Forward Force Limit	Immediately
Pn484	30					Reverse Force Limit	Immediately
Pn485	20					Polarity Detection Reference Speed	Immediately
Pn486	25					Polarity Detection Reference Acceleration/Deceleration Time	Immediately
Pn487	0					Polarity Detection Constant Speed Time	Immediately
Pn488	100					Polarity Detection Reference Waiting Time	Immediately
Pn48E	10					Polarity Detection Range	Immediately
Pn490	100					Polarity Detection Load Level	Immediately
Pn495	100					Polarity Detection Confirmation Force Reference	Immediately
Pn498	10					Polarity Detection Allowable Error Range	Immediately
Pn49F	0					Speed Ripple Compensation Enable Speed	Immediately
Pn502	20					Rotation Detection Level	Immediately
Pn503	10					Speed Coincidence Detection Signal Output Width	Immediately
Pn506	0					Brake Reference-Servo OFF Delay Time	Immediately
Pn507	100					Brake Reference Output Speed Level	Immediately
Pn508	50					Servo OFF-Brake Command Waiting Time	Immediately
Pn509	20					Momentary Power Interruption Hold Time	Immediately
Pn50A	1881h					Input Signal Selections 1	After restart
Pn50B	8882h					Input Signal Selections 2	After restart

Parameter Recording Table

Parameter No.	Default Setting					Name	When Enabled
Pn50E	0000h					Output Signal Selections 1	After restart
Pn50F	0100h					Output Signal Selections 2	After restart
Pn510	0000h					Output Signal Selections 3	After restart
Pn511	8543h					Input Signal Selections 5	After restart
Pn512	0000h					Output Signal Inverse Settings	After restart
Pn514	0000h					Output Signal Selections 4	After restart
Pn516	8888h					Input Signal Selections 7	After restart
Pn51B	1000					Motor-Load Position Deviation Overflow Detection Level	Immediately
Pn51E	100					Position Deviation Overflow Warning Level	Immediately
Pn520	5242880					Position Deviation Overflow Alarm Level	Immediately
Pn522	7					Positioning Completed Width	Immediately
Pn524	1073741824					Near Signal Width	Immediately
Pn526	5242880					Position Deviation Overflow Alarm Level at Servo ON	Immediately
Pn528	100					Position Deviation Overflow Warning Level at Servo ON	Immediately
Pn529	10000					Speed Limit Level at Servo ON	Immediately
Pn52A	20					Multiplier per Fully-closed Rotation	Immediately
Pn52B	20					Overload Warning Level	Immediately
Pn52C	100					Base Current Derating at Motor Overload Detection	After restart
Pn530	0000h					Program Jogging-Related Selections	Immediately
Pn531	32768					Program Jogging Travel Distance	Immediately
Pn533	500					Program Jogging Movement Speed	Immediately
Pn534	100					Program Jogging Acceleration/Deceleration Time	Immediately
Pn535	100					Program Jogging Waiting Time	Immediately
Pn536	1					Program Jogging Number of Movements	Immediately
Pn550	0					Analog Monitor 1 Offset Voltage	Immediately
Pn551	0					Analog Monitor 2 Offset Voltage	Immediately
Pn552	100					Analog Monitor 1 Magnification	Immediately
Pn553	100					Analog Monitor 2 Magnification	Immediately
Pn55A	1					Power Consumption Monitor Unit Time	Immediately
Pn560	400					Residual Vibration Detection Width	Immediately

Parameter Recording Table

Parameter No.	Default Setting					Name	When Enabled
Pn561	100					Overshoot Detection Level	Immediately
Pn581	20					Zero Speed Level	Immediately
Pn582	10					Speed Coincidence Detection Signal Output Width	Immediately
Pn583	10					Brake Reference Output Speed Level	Immediately
Pn584	10000					Speed Limit Level at Servo ON	Immediately
Pn585	50					Program Jogging Movement Speed	Immediately
Pn586	0					Motor Running Cooling Ratio	Immediately
Pn587	0000h					Polarity Detection Execution Selection for Absolute Linear Encoder	Immediately
Pn600	0					Regenerative Resistor Capacity	Immediately
Pn601	0					Dynamic Brake Resistor Capacity	Immediately
Pn603	0					Regenerative Resistance	Immediately
Pn604	0					Dynamic Brake Resistance	Immediately
Pn61A	0000h					Overheat Protection Selections	After restart
Pn61B	250					Overheat Alarm Level	Immediately
Pn61C	100					Overheat Warning Level	Immediately
Pn61D	0					Overheat Alarm Filter Time	Immediately

* The timing for enabling changes to parameter settings depends on the parameter. Refer to the following section for details on the enable timing.

→ [Chap. 17.2.2 'List of Parameters' ...page 623](#)

18 Appendices

18.1 Overview

The appendix provides information on interpreting panel displays, and tables of corresponding SERVOPACK and SigmaWin+ function names.





18.2 Interpreting Panel Displays

18.2.1 Overview

You can check the Servo Drive status on the panel display of the SERVOPACK. Also, if an alarm or warning occurs, the alarm or warning number will be displayed.

18.2.2 Interpreting Status Displays

The status is displayed as described below.

Display	Meaning
	/TGON (Rotation Detection) Signal Display Lit if the Servomotor speed is higher than the setting of Pn502 or Pn581 and not lit if the speed is lower than the setting. (The default setting is 20 min ⁻¹ or 20 mm/s.)
	Base Block Display Lit during the base block state (servo OFF). Not lit while the servo is ON.
	Reference Input Display Lit while a reference is being input.
	Connected Display Lit while there is a connection.

18.2.3 Alarm and Warning Displays

If there is an alarm or warning, the code will be displayed one character at a time, as shown below.

Example: Alarm A.E60

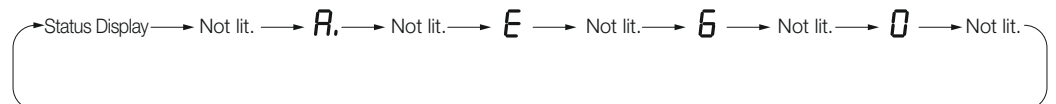


Fig. 388: Alarm Code Display A_E60

18.2.4 Hard Wire Base Block Active Display

If a hard wire base block (HWBB) is active, the display will change in the following order.

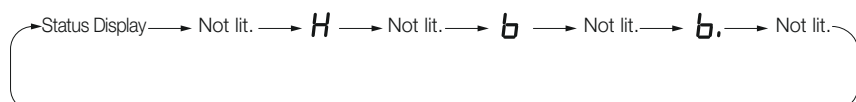


Fig. 389: Hard Wire Base Block Active Display

18.2.5 Overtravel Display

If overtravel has occurred, the display will change in the following order.

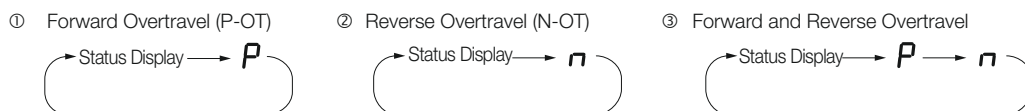


Fig. 390: Overtravel Display

18.2.6 Forced Stop Display

During a forced stop, the following display will appear.

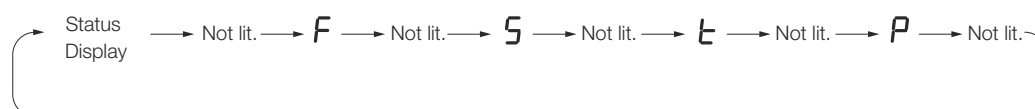
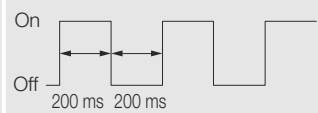
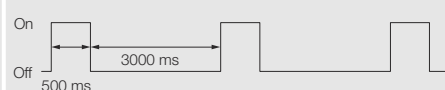


Fig. 391: Forced Stop Display

18.2.7 PROFINET Communications Indicators

Green LED (RUN) states

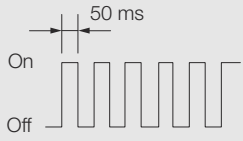
Green LED (RUN)	State	Flash rates
LED off	There is no connection to the IO-Controller.	Never lit.
LED on	Connection established with IO-Controller and in RUN mode.	Always lit.
LED blinking	Connection established with IO-Controller and in STOP mode.	Equal on and off times with a frequency of approximately 2,5 Hz: on for approximately 200 ms followed by off for approximately 200 ms. 
LED Flash Once	DCP Flash signal	Flash Once means to flash the LED with a duration of 3 sec with a frequency of 1 Hz (500 ms on, 500 ms off). 

Red LED (BF) states

Red LED (BF)	State	Description
Off	No error	The device is ready to communicate
On	Error	Communication error occurs, Run mode cyclic communication has been interrupted and no connection established.

Green LED Link/Activity status

The Link/Activity indicators show whether Communications Cables are connected to the CN6A and CN6B connectors and whether communications are active.

Green LED state	Link	Activity
On	Yes	A Communications Cable is connected, but data communications are not being performed.
Flickering	Yes	Data communications are in progress. 
Off	No	A Communications Cable is not connected and the PROFINET controller is not running.

18.3 Corresponding SERVOPACK and SigmaWin+ Function Names

18.3.1 Overview

This section gives the names and numbers of the utility functions and monitor display functions used by the SERVOPACKs and the names used by the SigmaWin+.

18.3.2 Corresponding SERVOPACK Utility Function Names

SigmaWin+		SERVOPACK	
Menu Dialog Box Button	Function Name	Fn No.	Function Name
Setup	Origin Search	Fn003	Origin Search
	Absolute Encoder Reset	Fn008	Reset Absolute Encoder
	Adjust the Analog Monitor Output	Fn00C	Adjust Analog Monitor Output Offset
		Fn00D	Adjust Analog Monitor Output Gain
	Adjust the Motor Current Detection Signal Offsets	Fn00E	Autotune Motor Current Detection Signal Offset
		Fn00F	Manually Adjust Motor Current Detection Signal Offset
	Multiturn Limit Setting	Fn013	Multiturn Limit Setting after Multiturn Limit Disagreement Alarm
	Reset Option Module Configuration Error	Fn014	Reset Option Module Configuration Error
	Initialize Vibration Detection Level	Fn01B	Initialize Vibration Detection Level
	Set Origin	Fn020	Set Absolute Linear Encoder Origin
	Reset Motor Type Alarm	Fn021	Reset Motor Type Alarm
	Software Reset	Fn030	Software Reset
	Polarity Detection	Fn080	Polarity Detection
	Tuning-less Level Setting	Fn200	Tuning-less Level Setting

Corresponding SERVOPACK and SigmaWin+ Function Names > Corresponding SERVOPACK Monitor Display Function Names

SigmaWin+		SERVOPACK	
Menu Dialog Box Button	Function Name	Fn No.	Function Name
	Easy FFT	Fn206	Easy FFT
Parameters	Initialize	Fn005	Initializing Parameters
	Write Prohibition Setting	Fn010	Write Prohibition Setting
	Setup Wizard	–	–
Tuning	Autotuning without Host Reference	Fn201	Advanced Autotuning without Reference
	Autotuning with Host Reference	Fn202	Advanced Autotuning with Reference
	Custom Tuning	Fn203	One-Parameter Tuning
	Adjust Anti-resonance Control	Fn204	Adjust Anti-resonance Control
	Vibration Suppression	Fn205	Vibration Suppression
	Moment of Inertia Estimation	–	–
Monitoring	Product Information	Fn011	Display Servomotor Model
		Fn012	Display Software Version
		Fn01E	Display SERVOPACK and Servomotor IDs
		Fn01F	Display Servomotor ID from Feedback Option Module
Test Operation	Jog	Fn002	Jog
	Jog Program	Fn004	Jog Program
Alarms	Alarm Display	Fn000	Display Alarm History
		Fn006	Clear Alarm History
Solutions	Mechanical Analysis	–	–

18.3.3 Corresponding SERVOPACK Monitor Display Function Names

SigmaWin+		SERVOPACK	
Menu Dialog Box Button	Name [Unit]	Un No.	Name [Unit]
Motion Monitor	Motor Speed [min ⁻¹]	Un000	Motor Speed [min ⁻¹]
	Speed Reference [min ⁻¹]	Un001	Speed Reference [min ⁻¹]
	Torque Reference [%]	Un002	Torque Reference [%] (percentage of rated torque)

Corresponding SERVOPACK and SigmaWin+ Function Names > Corresponding SERVOPACK Monitor Display Function Names

SigmaWin+		SERVOPACK	
Menu Dialog Box Button	Name [Unit]	Un No.	Name [Unit]
	<ul style="list-style-type: none"> ■ Rotary Servomotors: Rotational Angle 1 [encoder pulses] (number of encoder pulses from origin within one encoder rotation) ■ Linear Servomotors: Electrical Angle 1 [linear encoder pulses] (linear encoder pulses from the polarity origin) 	Un003	<ul style="list-style-type: none"> ■ Rotary Servomotors: Rotational Angle 1 [encoder pulses] (number of encoder pulses from origin within one encoder rotation displayed in decimal) ■ Linear Servomotors: Electrical Angle 1 [linear encoder pulses] (linear encoder pulses from the polarity origin displayed in decimal)
	<ul style="list-style-type: none"> ■ Rotary Servomotors: Rotational Angle 2 [deg] (electrical angle from origin within one encoder rotation) ■ Linear Servomotors: Electrical Angle 2 [deg] (electrical angle from polarity origin) 	Un004	<ul style="list-style-type: none"> ■ Rotary Servomotors: Rotational Angle 2 [deg] (electrical angle from polarity origin) ■ Linear Servomotors: Electrical Angle 2 [deg] (electrical angle from polarity origin)
	Input Reference Pulse Speed [min ⁻¹]	Un007	Input Reference Pulse Speed [min ⁻¹] (displayed only during position control)
	Position Deviation [reference units]	Un008	Position Error Amount [reference units] (displayed only during position control)
	Accumulated Load Ratio [%]	Un009	Accumulated Load Ratio [%] (percentage of rated torque: effective torque in cycles of 10 seconds)
	Regenerative Load Ratio [%]	Un00A	Regenerative Load Ratio [%] (percentage of processable regenerative power: regenerative power consumption in cycles of 10 seconds)
	Dynamic Brake Resistor Power Consumption [%]	Un00B	Power Consumed by DB Resistance [%] (percentage of processable power at DB activation: displayed in cycles of 10 seconds)
	Input Reference Pulse Counter [reference units]	Un00C	Input Reference Pulse Counter [reference units]
	Feedback Pulse Counter [encoder pulses]	Un00D	Feedback Pulse Counter [encoder pulses]

Corresponding SERVOPACK and SigmaWin+ Function Names > Corresponding SERVOPACK Monitor Display Function Names

SigmaWin+		SERVOPACK	
Menu Dialog Box Button	Name [Unit]	Un No.	Name [Unit]
	Fully-closed Loop Feedback Pulse Counter [external encoder resolution]	Un00E	Fully-closed Loop Feedback Pulse Counter [external encoder resolution]
	Upper Limit Setting of Motor Maximum Speed/Upper Limit Setting of Encoder Output Resolution	Un010 [*] 1	Upper Limit Setting of Motor Maximum Speed/ Upper Limit Setting of Encoder Output Resolution
	Total Operation Time [100 ms]	Un012	Total Operation Time [100 ms]
	Feedback Pulse Counter [reference units]	Un013	Feedback Pulse Counter [reference units]
	Overheat Protection Input [0.01 V]	Un02F	Overheat Protection Input [0.01 V]
	Current Backlash Compensation Value [0.1 reference units]	Un030	Current Backlash Compensation Value [0.1 reference units]
	Backlash Compensation Value Setting Limit [0.1 reference units]	Un031	Backlash Compensation Value Setting Limit [0.1 reference units]
	Power Consumption [W]	Un032	Power Consumption [W]
	Consumed Power [0.001 Wh]	Un033	Consumed Power [0.001 Wh]
	Cumulative Power Consumption [Wh]	Un034	Cumulative Power Consumption [Wh]
	Absolute Encoder Multiturn Data	Un040	Absolute Encoder Multiturn Data
	Position within One Rotation of Absolute Encoder [encoder pulses]	Un041	Position within One Rotation of Absolute Encoder [encoder pulses]
	Lower Bits of Absolute Encoder Position [encoder pulses]	Un042	Lower Bits of Absolute Encoder Position [encoder pulses]
	Upper Bits of Absolute Encoder Position [encoder pulses]	Un043	Upper Bits of Absolute Encoder Position [encoder pulses]
Status Monitor	Polarity Sensor Signal Monitor	Un011	Polarity Sensor Signal Monitor
	Active Gain Monitor	Un014	Effective Gain Monitor (gain settings 1 = 1, gain settings 2 = 2)
	Safety I/O Signal Monitor	Un015	Safety I/O Signal Monitor
Input Signal Monitor	Input Signal Monitor	Un005	Input Signal Monitor
Output Signal Monitor	Output Signal Monitor	Un006	Output Signal Monitor

Corresponding SERVOPACK and SigmaWin+ Function Names > Corresponding SERVOPACK Monitor Display Function Names

SigmaWin+		SERVOPACK	
Menu Dialog Box Button	Name [Unit]	Un No.	Name [Unit]
Service Life Monitor	Installation Environment Monitor – SERVOPACK	Un025	SERVOPACK Installation Environment Monitor [%]
	Installation Environment Monitor – Servomotor* ²	Un026* ₂	Servomotor Installation Environment Monitor [%]
	Service Life Prediction Monitor – Built-in Fan	Un027	Built-in Fan Remaining Life Ratio [%]
	Service Life Prediction Monitor – Capacitor	Un028	Capacitor Remaining Life Ratio [%]
	Service Life Prediction Monitor – Surge Prevention Circuit	Un029	Surge Prevention Circuit Remaining Life Ratio [%]
	Service Life Prediction Monitor – Dynamic Brake Circuit	Un02A* ³	Dynamic Brake Circuit Remaining Life Ratio [%]
	Service Life Prediction Monitor – Built-in Brake Relay	Un036	Built-in Brake Relay Remaining Life Ratio [%]
Product Information	Motor – Resolution	Un084	Linear Encoder Pitch (Scale pitch = Un084 × 10 ^{Un085} [µm])
		Un085	Linear Encoder Pitch Exponent (Scale pitch = Un084 × 10 ^{Un085} [µm])
–	–	Un020	Rated Motor Speed [min ⁻¹]
		Un021	Maximum Motor Speed [min ⁻¹]

*1.

You can use Un010 to monitor the upper limit setting for the maximum motor speed or the upper limit setting for the encoder output resolution.

You can monitor the upper limit of the encoder output resolution setting (Pn281) for the current maximum motor speed setting (Pn385), or you can monitor the upper limit of the maximum motor speed setting for the current encoder output resolution setting.

Select which signal to monitor with Pn080 = n.X□□□ (Calculation Method for Maximum Speed or Divided Output Pulses).

- If Pn080 = n.0□□□, the encoder output resolution (Pn281) that can be set is displayed.
- If Pn080 = n.1□□□, the maximum motor speed (Pn385) that can be set is displayed in mm/s.

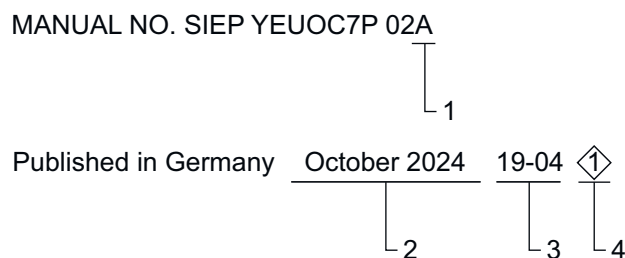
*2.

This applies to the following motors. The display will show 0 for all other models.

SGM7M, SGM7J, SGM7A, SGM7P, SGM7G, SGM7E, SGM7F, and SGMCV

19 Revision history

The revision dates and numbers of the revised manuals are given on the bottom of the back cover.



- 1 Manual version
- 2 Date of publication
- 3 Date of original publication
- 4 Revision number

Date of publication	Rev. no.	Section	Revised content
April 2019	-	-	First edition
October 2024	1	15.7 PROFIdrive Position Mode	The description of 2532h (Traversing Block Selection (SATZANW)), 2536h (MDI Acceleration (MDI_ACC)) and 2537h (MDI Deceleration (MDI_DEC)) has been corrected.
		17.3 Object List	The description of 2538h (MDI Mode (MDI_MOD)) has been corrected.

PROFINET Communications

Sigma-7 SERVOPACK SGD7S-□□□AC0□□□□, 200 V

Technical Manual

YASKAWA EUROPE GmbH

Philipp-Reis-Str. 6
65795 Hattersheim am Main
Germany
Phone: +49-6196-569-300
Fax: +49-6196-569-398
www.yaskawa.eu
E-mail: info@yaskawa.eu

Importer United Kingdom

YASKAWA ELECTRIC UK LTD.

1 Hunt Hill, Orchardton Woods,
Cumbernauld, G68 9 LF,
United Kingdom
Phone: +44 (0) 1236-735000

YASKAWA AMERICA, INC.

2121, Norman Drive South,
Waukegan, IL 60085, U.S.A.
Phone: +1-800-YASKAWA (927-
5292) or +1-847-887-7000
Fax: +1-847-887-7310
www.yaskawa.com

YASKAWA ELÉTRICO DO BRASIL, Ltda.

Avenida Piraporinha 777,
Diadema, São Paulo
09950-000, Brasil
Phone: +55-11-3585-1100
www.yaskawa.com.br

DRIVE CENTER

(Inverter Plant)

2-13-1, Nishimiyaichi,
Yukuhashi, Fukuoka
824-8511, Japan
Phone: +81-930-25-2548
www.yaskawa.co.jp

IRUMA BUSINESS CENTER

(Solution Center)

480, Kamifujisawa, Iruma,
Saitama,
358-8555, Japan
Phone: +81-4-2962-5151
www.yaskawa.co.jp

In the event that the end user of this product is to be the military and said product is to be employed in any weapons systems or the manufacture thereof, the export will fall under the relevant regulations as stipulated in the Foreign Exchange and Foreign Trade Regulations. Therefore, be sure to follow all procedures and submit all relevant documentation according to any and all rules, regulations and laws that may apply. Specifications are subject to change without notice for ongoing product modifications and improvements.

Contact Yaskawa or your nearest sales representative for details on the contents of this manual.

© 2010-2024 YASKAWA ELECTRIC CORPORATION