

MOTOMAN MPL500 II

Palletising with the MPL-series



The versatile and powerful 4-axis MOTOMAN MPL500 II robot provides high performance in box palletising, case palletising and many further logistical tasks for end-of-line or distribution center automation.

Its extensive vertical reach of 3024 mm combined with 3159 mm horizontal reach enables high palletising loads. The empty tube for internally routed airlines and cables from base to U-axis maximize system reliability.

The MPL500 II is driven by the high-performance DX200 controller which is available with the optional Category 3 Functional Safety Unit (FSU), providing a variety of new safety functions.

KEY BENEFITS

- Compact, flexible and powerful
- High acceleration and speed:
Up to 1200 cycles/h palletizing capa, suitable for box palletising
- High Payload: 500 kg
- Large motion range:
 - 2624 mm square reach
(on pallet 1300 x 1300 mm)
 - 2363 mm stack height
(on pallet 1600 x 1600 mm)
- Maximum reliability, empty tube for internally routed airlines and cables
- Enhanced Safety Functions for DX200 Functional Safety Controller (FSU)
- Protection class IP54/67

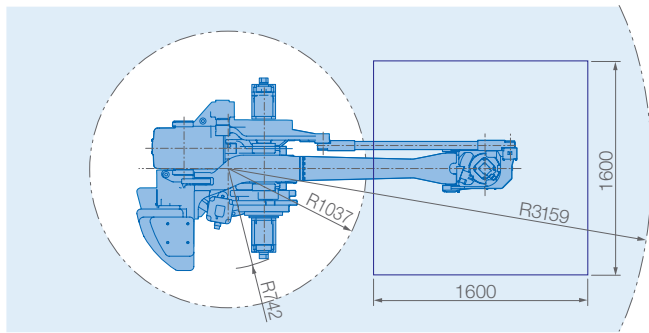
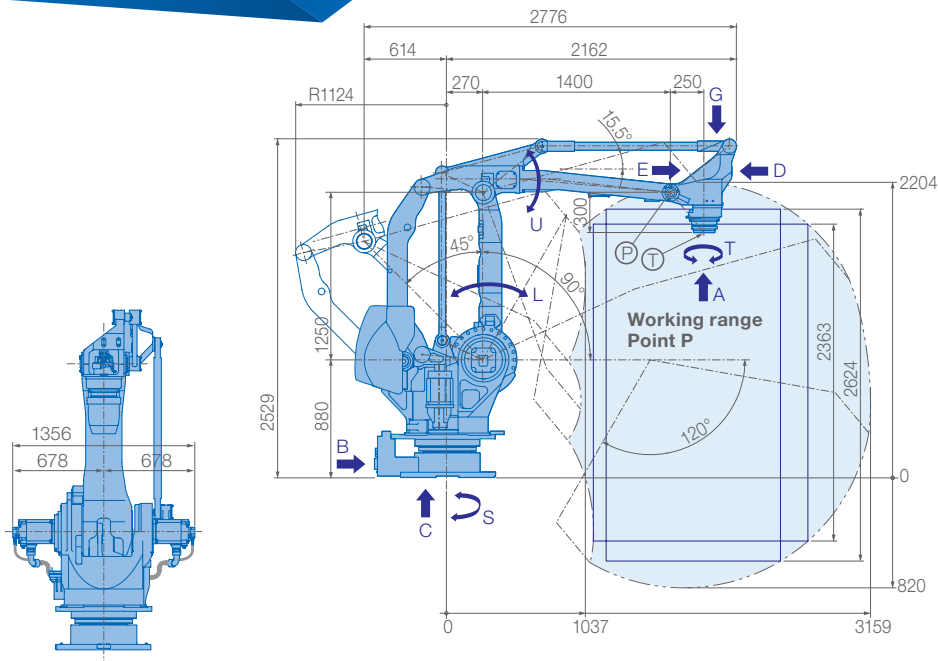

Allowable wrist load

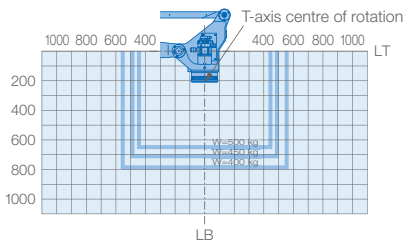

View A

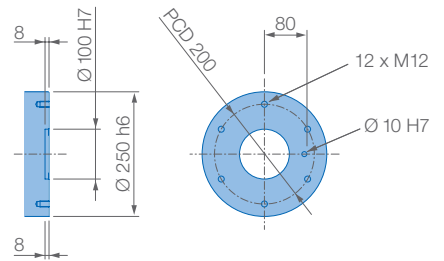

View B

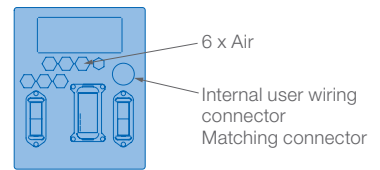

View C

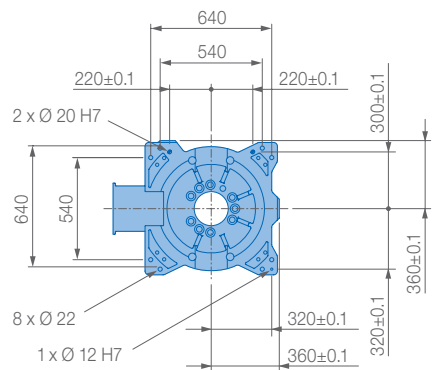

Mounting option: Floor
Protection class: IP54/67



Specifications MPL500 II					
Axes	Maximum motion range [°]	Maximum speed [°/sec.]	Allowable moment [Nm]	Allowable moment of inertia [kg · m ²]	Controlled axes
S	±180	80	-	-	4
L	+90/-45	85	-	-	Max. payload [kg]
U	+15.5/-120	85	-	-	Repeatability [mm]
R	-	-	-	-	Max. working range R [mm]
B	-	-	-	-	Temperature [°C]
T	±360	195	-	200	Humidity [%]
					Weight [kg]
					Power supply, average [KVA]